



Piper Aircraft, Inc.
2926 Piper Drive
Vero Beach, FL, U.S.A. 32960

SERVICE NO. 1331 LETTER

Date: June 4, 2024

(S) (M)

SUBJECT:

IMPROVED SPRING ATTACHMENT PLATE

MODELS AFFECTED:

PA-28R-180 Arrow

PA-28R-200 Arrow

PA-28R-200 Arrow II
PA-28R-201 Arrow III / Arrow

PA-28R-201T Turbo Arrow III
PA-28RT-201 Arrow IV
PA-28RT-201T Turbo Arrow IV
PA-32R-300 Lance
PA-32R-301 Saratoga SP
PA-32R-301T Turbo Saratoga SP
PA-32R-301 Saratoga II HP
PA-32R-301T Saratoga II TC
PA-32RT-300 Lance II
PA-32RT-300T Turbo Lance II
PA-34-200 Seneca
PA-34-200T Seneca II
PA-34-220T Seneca III

PA-34-220T Seneca IV
PA-34-220T Seneca V / Seneca
PA-44-180 Seminole

PA-44-180T Turbo Seminole

SERIAL NUMBERS AFFECTED:

28R-30001 thru 28R-31270,
28R-7130001 thru 28R-7130013

28R-30001 thru 28R-31270,
28R-7130001 thru 28R-7130013

28R-7235001 thru 28R-7635545

28R-7737001 thru 28-7837317, 2837001 thru 2837061,
2844001 thru 2844130

28R-7703001 thru 28R-7803373, 2803001 thru 2803012
28R-7918001 thru 28R-8218026
28R-7931001 thru 28R-8631004, 2831001 thru 2831038
32R-7680001 thru 32R-7880068
32R-8013001 thru 32R-8613006, 3213001 thru 3213041
32R-8029001 thru 32R-8629008, 3229001 thru 3229003
3213029 thru 3213103, 3246001 thru 3246244
3257001 thru 3257439
32R-7885001 thru 32R-7985106
32R-7887001 thru 32R-7987126
34-7250001 thru 34-7450220
34-7570001 thru 34-8170092
34-8133001 thru 34-8633014, 3433001 thru 3433172,
3448001 thru 3448035
3448038 thru 3448079, 3447001 thru 3447029
3449001 thru 3449506
44-7995001 thru 44-8195026, 4495001 thru 4495013,
4496001 thru 4496230
44-8107001 thru 44-8207020

COMPLIANCE TIME:

At owner/operator discretion.

APPROVAL:

The engineering aspects of this service document have been shown to comply with the applicable Federal Aviation Regulations and are FAA approved.

PURPOSE:

This service letter announces the availability of an improved spring attachment plate for affected aircraft. This improved plate reduces the possibility of landing gear failure in service. This service letter recommends a one time inspection and, on condition, replacement of the spring attachment plates.

ATA/JASC: 3210

(OVER)

INSTRUCTIONS:

1. Verify if the aircraft is currently equipped with the factory installed or improved spring attachment plates.
NOTE: Some aircraft may have previously installed the improved plates via service replacements.
 - a. Locate the spring attachment plate on each main landing gear as shown in Figure 1.
 - b. Measure the material thickness of each spring attachment plate.
 - If the thickness of the plate is 0.090 inches, no further action is required; proceed to step 3.
 - If the thickness of the plate is 0.063 inches, further action is required; proceed to step 2.
2. Order and replace the spring attachment plates, Piper P/N 67753-000. Refer to Chapter 32-10-00 of the applicable Piper airplane maintenance manual (AMM) or the appropriate section of the applicable Piper service manual (SM) for instructions on removal and installation of main landing gear components. Replace fastener hardware on condition.
NOTE: Refer to the section index guide of the applicable service manual; the section on retractable landing gear varies between each Piper SM.
3. Make a logbook entry documenting compliance with this service letter.

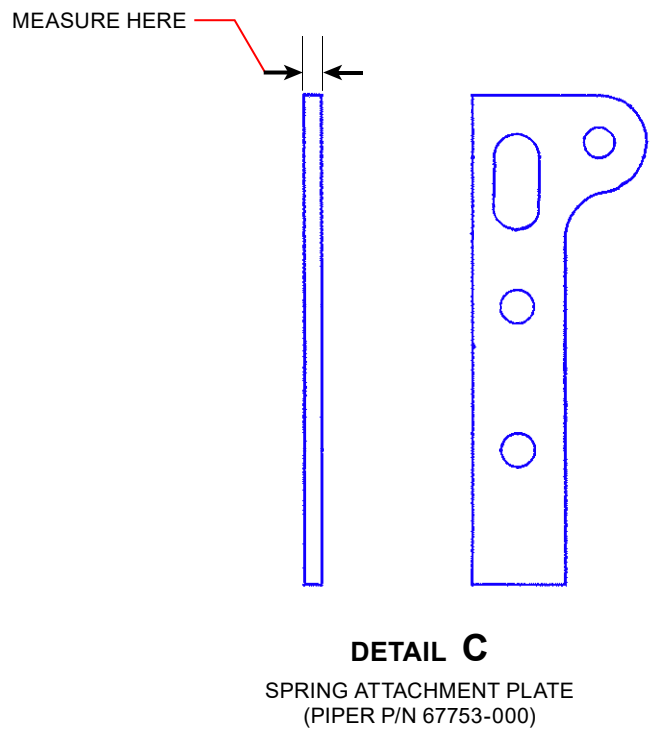
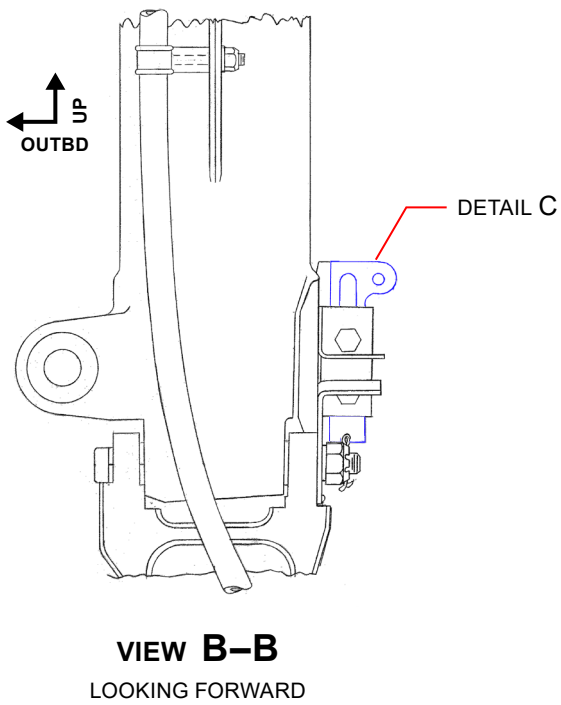
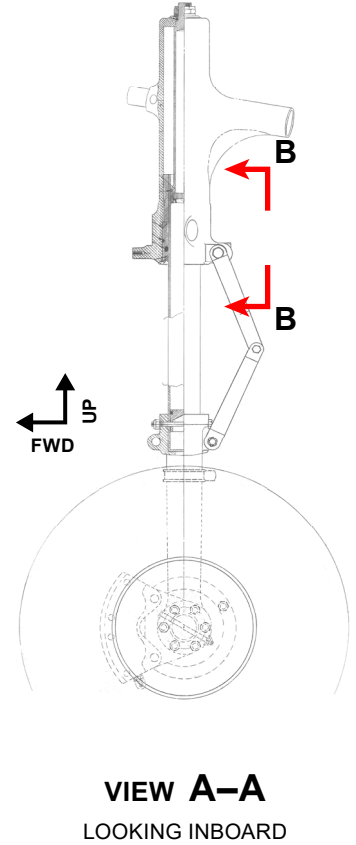
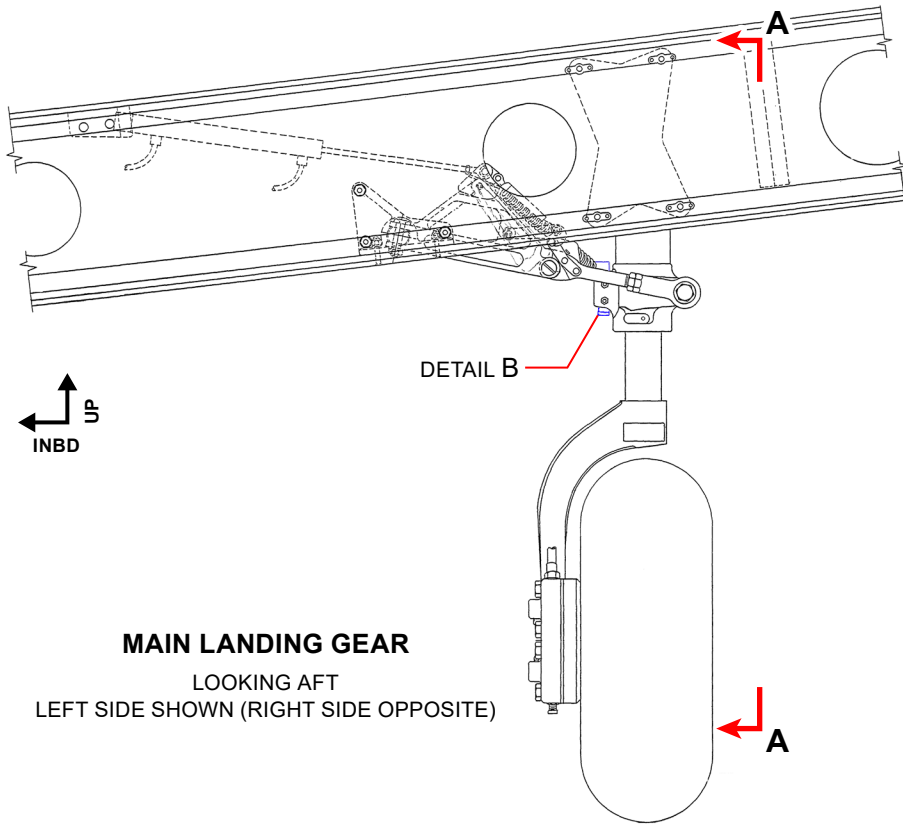

Figure 1
Spring Attachment Plate Installation
(PA-44-180 shown, other models similar)

MATERIAL REQUIRED: On condition, two (2) each, Plate – Spring Attachment, Piper P/N 67753-000, per aircraft.

AVAILABILITY OF PARTS: Your Piper Approved Service Center –
Find your local service center at <https://www.piper.com/>

EFFECTIVITY DATE: This service letter is effective on June 11, 2024.

SUMMARY: Please contact your Piper Approved Service Center to make arrangements for compliance with this service letter in accordance with the compliance time indicated.

NOTE: Please notify the factory of any address/ownership corrections. Changes should include aircraft model, serial number, and current owner's name and address.

Corrections and/or changes should be directed to:

PIPER AIRCRAFT, INC.
Attn: Customer Service
2926 Piper Drive
Vero Beach, FL 32960
or:
CustomerService@piper.com
Please include in subject line: "Aircraft ownership update"