



**SENECA II
SERVICE MANUAL**

CARD 1 OF 3

PA-34-200T SENECA II

PIPER AIRCRAFT CORPORATION

(PART NUMBER 761 590)

1A1

PIPER SENECA II SERVICE MANUAL

AEROFICHE EXPLANATION AND REVISION STATUS

Service manual information incorporated in this set of Aerofiche cards is arranged in accordance with the general specifications of Aerofiche adopted by the General Aviation Manufacturer's Association. Information compiled in this Aerofiche service manual is kept current by revisions distributed periodically. These revisions supersede all previous revisions, are complete Aerofiche card replacements, and supersede Aerofiche cards of the same number in the set.

Identification of revised material:

Revised text and illustrations are indicated by a black vertical line along the left-hand margin of the frame, opposite revised or added material. Revision lines indicate only current revisions with changes and additions to existing text and illustrations. Changes in capitalization, spelling, punctuation, indexing, physical location of the material, or complete page additions are not identified by revision lines.

Interim Revisions*

If there is more than one interim revision on a page, the most recent will have the letters IR next to the revision line. Any other revision lines may reflect a previous permanent revision or previous interim revision. Check the Revision Status page for revision history.

Revisions to Service Manual 761 590 issued October 11, 1979 are as follows:

Effectivity	Publication Date	Aerofiche Card Effectivity
ORG791011	October 11, 1979	1, 2 and 3
PR800810	August 10, 1980	1, 2 and 3
PR810316	March 16, 1981	1, 2 and 3
PR821112	November 12, 1982	1, 2 and 3
PR831208	December 8, 1983	1, 2 and 3
IR860730	July 30, 1986	1
IR860920	September 20, 1986	1
IR870506	June 12, 1987	1
IR960624	June 24, 1996	1
IR970205*	February 5, 1997	1

This publication contains material revised as of December 8, 1983 (with five interim revisions effective July 30, 1986, September 20, 1986, May 6, 1987, June 24, 1996, and February 5, 1997).

*** INTERIM CHANGE**

Revisions appear in Sections III, V, and VII of card 1. There are no other changes in this service manual. Please discard your current card 1 and replace it with this revised one. DO NOT DISCARD CARDS 2 or 3.

TABLE OF CONTENTS

	AEROFICHE CARD NO. 1	GRID NO.
I	INTRODUCTION	1A13
II	HANDLING AND SERVICING	1A16
III	INSPECTION	1C23
IV	STRUCTURES	1D12
V	SURFACE CONTROLS	1F21
VI	HYDRAULIC SYSTEM	1I3
VII	LANDING GEAR AND BRAKE SYSTEM	1J5

AEROFICHE CARD NO. 2

VIII	POWERPLANT	2A9
IX	FUEL SYSTEM	2D4
X	INSTRUMENTS	2E8
XI	ELECTRICAL SYSTEM	2F16
XII	ELECTRONICS	2I20
XIII	HEATING AND VENTILATING SYSTEM	2J6

AEROFICHE CARD NO. 3

XIV	ACCESSORIES AND UTILITIES	3A6
-----	---------------------------------	-----

1A4
INTENTIONALLY LEFT BLANK

LIST OF ILLUSTRATIONS

Figure		Aerofiche Grid No.
2-1.	Three View	1A19
2-2.	Station References	1A20
2-2A.	Torque Wrench Formula	1B1
2-3.	Access Plates and Panels	1B5
2-4.	Jacking	1B7
2-5.	Weighing	1B8
2-6.	Leveling Airplane	1B9
2-7.	Turning Distance	1B14
2-8.	Service Points	1B16
2-9.	Lubrication Chart (Landing Gear, Main)	1C2
2-10.	Lubrication Chart (Landing Gear, Nose)	1C3
2-11.	Lubrication Chart (Control System)	1C4
2-12.	Lubrication Chart (Control System) (cont.)	1C5
2-13.	Lubrication Chart (Power Plant and Propeller)	1C6
2-14.	Lubrication Chart (Cabin Door, Baggage Doors and Seats)	1C7
4-1.	Cherrylock Rivet Removal	1D15
4-1a.	Hose/Line Markings	1D16
4-1b.	Flareless Tube Fittings	1D18
4-1c.	Aileron and Flap Installation	1D22
4-2.	Wing Installation	1E1
4-3.	Empennage Group	1E7
4-4.	Method of Securing Control Cables	1E11
4-5.	Windshield Installation	1E13
4-6.	Side Window Installation (Typical)	1E14
4-7.	Rear Door Window Replacement	1E16
4-7a.	Snubber Installation	1E18
4-8.	Seat Back Lock	1E23
4-9.	Skin Materials and Thickness	1F3
4-10.	Surfaces Scratches, Abrasions or Ground-in-Dirt	1F8
4-11.	Deep Scratches, Shallow Nicks and Small Holes	1F8
4-12.	Mixing of Epoxy Patching Compound	1F9
4-13.	Welding Repair Method	1F9
4-14.	Repairing of Cracks	1F10
4-15.	Various Repairs	1F11
4-16.	Repair of Stress Lines	1F12
4-17.	Repair of Impacted Damage	1F12
4-18.	Control Surface Balance Tool	1F16
4-19.	Aileron and Rudder Balance Configuration	1F18
4-20.	Stabilator Balance Configurations	1F19
5-1.	Control Column Assembly	1G1
5-1a.	Correct Method of Installing Rod End Bearing	1G4
5-2.	Aileron Controls	1G5

PIPER SENECA II SERVICE MANUAL

LIST OF ILLUSTRATIONS (cont.)

Figure		Aerofiche Grid No.
5-3.	Bellcrank Rigging Tool	1G9
5-4.	Aileron Rigging Tool	1G10
5-5.	Stabilator and Stabilator Trim Controls	1G13
5-6.	Stabilator Rigging Tool	1G16
5-7.	Methods of Securing Trim Cables	1G16
5-8.	Rudder and Brake Pedal Assembly	1G22
5-9.	Rudder and Rudder Trim Controls	1H1
5-10.	Rudder Rigging Tool	1H3
5-11.	Clamping Rudder Pedals	1H3
5-12.	Rudder and Stabilator Travel Adjustment	1H4
5-13.	Flap Controls	1H9
5-14.	Flap Step Adjustment	1H11
5-15.	Flap Rigging Tool	1H11
5-16.	Fabricated Aileron Bellcrank Rigging Tool	1H13
5-17.	Fabricated Aileron and Flap Rigging Tool	1H14
5-18.	Fabricated Stabilator Rigging Tool	1H15
5-19.	Fabricated Rudder Rigging Tool	1H16
6-1.	Schematic Diagram of Hydraulic System	1I7
6-2.	Hydraulic System Installation	1I8
6-3.	Hydraulic Pump/Reservoir, Exploded View	1I11
6-4.	Test and Adjustments of Hydraulic Pump	1I14
6-5.	Pump Mounting	1I15
6-6.	Free-Fall Valve Assembly	1I15
6-7.	Gear Actuating Cylinder	1I16
6-7a.	Installation of T-Rings	1I17
6-8.	End Gland Locking Device	1I18
6-9.	Nose Gear Actuating Cylinder Installation	1I20
7-1.	Nose Gear Oleo Strut Assembly	1J9
7-1a.	Nose Gear Service Tolerances	1J11
7-2.	Nose Gear Installation	1J16
7-3.	Clamping Rudder Pedals in Neutral Position	1K2
7-4.	Rudder Pedals at Neutral Angle	1K2
7-5.	Main Gear Oleo Strut Assembly	1K4
7-5a.	Main Gear Service Tolerances	1K6
7-6.	Main Gear Installation	1K10
7-7.	Aligning Main Gear	1K16
7-8.	Toe-In/Toe-Out Adjustment	1K17
7-9.	Adjust Nose Gear Down Limit Switch	1K19
7-10.	Adjust Main Gear Down Limit Switch	1K19
7-11.	Throttle Warning Switch	1K20
7-12.	Nose Wheel Assembly	1L1
7-13.	Main Wheel Assembly	1L3
7-14.	Wheel Brake Assembly	1L4

Revised: 12/08/83

LIST OF ILLUSTRATIONS (cont.)

Figure		Aerofiche Grid No.
7-15.	Removal and Installation of Anchor Bolts	1L5
7-16.	Brake Master Cylinder (Hand, Parking Brake)	1L7
7-17.	Brake System Installation	1L8
7-18.	Brake Cylinder (17000) (Toe Brake)	1L9
7-19.	Brake Cylinder (10-27) (Toe Brake)	1L9
7-20.	Brake Cylinder (10-30) (Toe Brake)	1L10
7-21.	Brake Reservoir	1L14
7-22.	Bleeding Brake	1L14
8-1.	Engine Cowling Installation	2A14
8-2.	Cowl Flap Installation	2A14
8-3.	Propeller Installation	2A16
8-4.	Typical Nicks and Removal Method	2A17
8-5.	Propeller Governor	2A20
8-6.	Engine Installation	2A23
8-7.	Schematic Diagram of Turbocharger System	2B5
8-8.	Induction System Installation	2B6
8-8a.	Magneto Assembly	2B9
8-9.	Contact Spring Inspection	2B11
8-10.	Contact Points	2B12
8-11.	Impulse Coupling	2B12
8-12.	Flyweight Clearance of Impulse Coupling	2B13
8-13.	Rotor Holding Tool Installed	2B14
8-14.	Timing Kit Installed	2B14
8-15.	Cast-In Timing Marks	2B15
8-16.	Fabricated Pointer	2B15
8-17.	Engine Timing Marks	2B17
8-18.	Removing Spring From Lead Assembly	2B19
8-19.	Assembly Tool	2B20
8-20.	Assembly Tool Application	2B20
8-21.	Measuring Lead Assembly Length	2B20
8-22.	Ferrule Seating Tool	2B22
8-23.	Measuring Wire From Top of Ferrule	2B22
8-24.	Needle	2B22
8-25.	Installing Grommet Over Lead Assemblies	2B22
8-26.	Lead Assembly Installed in Grommet	2B23
8-27.	Wire Doubled Over For Installation of Eyelet	2B23
8-28.	Ignition Schematic	2B24
8-29.	Removing Frozen Spark Plug	2C3
8-30.	Lubrication System Maintenance Points	2C6
8-31.	Schematic Diagram of Fuel Injection System	2C8
8-32.	Fuel Injector Nozzle Assembly	2C9
8-33.	Engine Controls	2C10
8-34.	Idle Speed and Mixture Adjustment Points	2C12
8-35.	Sectional View of Altitude Compensating Fuel Pump Assembly	2C16
8-36.	Exhaust Bypass Valve Screw	2C18

PIPER SENECA II SERVICE MANUAL

LIST OF ILLUSTRATIONS (cont.)

Figure		Aerofiche Grid No.
9-1.	Fuel System Schematic	2D7
9-2.	Fuel Cell Installation	2D12
9-3.	Fuel Gauges	2D20
9-4.	Fuel Filter	2D20
9-5.	Fuel Selector Valve	2D23
9-6.	Slider Resistor Terminal	2E1
9-6a.	Resistor Set-Up/Test for Fuel Quantity Gauge	2E3
9-6b.	Maximum Deviation of Fuel Quantity Gauge Needle	2E4
10-1.	Gyro Pressure System	2E14
10-2.	Pitot-Static System, Serial Nos. 34-7570001 to 34-7670136 incl.	2E16
10-2a.	Pitot-Static System, Serial Nos. 34-7670137 and up	2E17
10-3.	Instrument Panel	2E18
11-1.	Switch Panel - For Models Without Primer System	2F21
11-1a.	Switch Panel - For Models With Primer System	2F22
11-2.	Removal of Slip Ring End Bearing	2G1
11-3.	Removal of Rectifier	2G1
11-4.	Testing Rotor for Ground	2G4
11-5.	Testing Rotor for Shorts	2G4
11-6.	Installation of Rectifier	2G5
11-7.	Terminal Assembly	2G6
11-8.	Slip Ring End Bearing Assembly	2G7
11-9.	Testing Alternator	2G7
11-10.	Regulator Diagram	2G10
11-11.	Testing Regulator	2G12
11-12.	Adjusting Regulator	2G13
11-13.	Application of Overvoltage Control	2G15
11-14.	Testing Overvoltage Control	2G15
11-15.	Exploded View of Starting Motor	2G17
11-16.	Turning Motor Commutator	2G18
11-17.	Testing Motor Armature for Shorts	2G18
11-18.	Testing Motor Fields for Grounds	2G19
11-19.	No-Load Test Hookup	2G19
11-20.	Stall Torque Hookup	2G20
11-21.	Landing Light Adjustment	2H1
11-22.	Adjusting Lift Detector Micro Switch	2H2

NOTE

Electrical Schematics for Section XI, see 2F18

12-1.	Two Year, Magnesium Battery Connections	2I22
12-2.	Garrett ELT Schematic	2I23
12-3.	Communications Components ELT Schematic	2J1
12-4.	Emergency Locator Transmitter Schematic (Narco)	2J1

LIST OF ILLUSTRATIONS (cont.)

Figure		Aerofiche Grid No.
12-5.	ELT Portable Folding Antenna (Narco)	2J3
12-6.	ELT Using Fixed Aircraft Antenna (Narco)	2J3
13-1.	Cabin Heater, Defroster and Fresh Air Installation	2J9
13-2.	Heater and Combustion Air Blower Assembly (30,000 BTU)	2J12
13-3.	Heater and Combustion Air Blower Assembly (45,000 BTU)	2J13
13-4.	Diagrammatic Cutaway of Heater to Show Whirling Flame Action	2J14
13-5.	Fuel Regulator and Shutoff Valve	2J16
13-6.	Top View - Duct Switch	2J16
13-7.	Wiring Diagram	2J20
13-8.	Primary Power Circuit	2J21
13-9.	Starting Power Circuit	2J22
13-10.	Spark Plug Fixture	2J24
13-11.	Wiring - Test Setup	2J24
13-12.	Spark Plug Gap Adjustment	2K1
13-13.	Ignition Unit Assembly	2K5
13-14.	Test Setup for Fuel Regulator and Shutoff Valve	2K8
13-15.	Heater Fuel Pump	2K9
13-16.	Suggested Design for Seal Plates, Plugs, and Caps for Combustion Tube Leakage Test	2K17
13-17.	Test Setup for Combustion Air Pressure Switch	2K17
13-18.	Exploded View of Heater Assembly (30,000 BTU)	2K21
13-19.	Exploded View of Heater Assembly (45,000 BTU)	2K22
13-20.	Exploded View - Combustion Air Blower and Motor Assembly (30,000 BTU)	2L3
13-21.	Exploded View - Combustion Air Blower and Motor Assembly (45,000 BTU)	2L4
13-22.	Suggested Setup of Heater Operation Test	2L6
13-23.	Wiring Connections for Heater Operation Test	2L6
13-24.	Spark Plug Gap Adjustment Tool	2L9
14-1.	Propeller Deicer Installation	3A12
14-2.	Electrical Diagram Showing Cycle Sequence - Phase I	3A13
14-3.	Electrical Diagram Showing Cycle Sequence - Phase II	3A13
14-4.	Electrical Diagram Showing Cycle Sequence - Phase III	3A14
14-5.	Electrical Diagram Showing Cycle Sequence - Phase IV	3A14
14-6.	Typical Use of Dial Indicator	3A16
14-7.	Centering of Brushes on Slip Rings	3A17
14-8.	Wiring Schematic - Electric Propeller Deicing System	3A19
14-9.	Brush Block Assembly	3A20
14-10.	Brush Module Assembly 3E2011	3A22
14-10a.	Alternate Module Stacking Arrangement	3A22
14-10b.	Modular Brush Assembly 3E2042-1 (2 Bladed Prop)	3A23
14-10c.	Modular Brush Assembly 3E2062-2 (3 Bladed Prop)	3A23
14-10d.	Angle of Contact Brushes to Slip Rings	3A24

PIPER SENECA II SERVICE MANUAL

LIST OF ILLUSTRATIONS (cont.)

Figure		Aerofiche Grid No.
14-11.	Propeller Deicer Installation	3B1
14-12.	Installation of Deicer Boot.....	3B3
14-13.	Wrinkled Deicers	3B6
14-14.	Sealer Application (Boot).....	3B7
14-15.	Pneumatic Deicer System Installation (S/N's to 34-8070144)	3B15
14-15a.	Pneumatic Deicer System Installation (S/N 34-8070144 and up)	3B16
14-16.	Pneumatic Deicer Boots Operation.....	3B18
14-17.	Pneumatic Deicer System Schematic	3B18
14-18.	Ice Detection Light Schematic	3C9
14-19.	Portable Oxygen Installation	3C15
14-20.	Fixed Oxygen System Installation (Optional)	3C16
14-20a.	Oxygen Tubing Installations	3C17
14-21.	Oxygen System Filler Valve Installation	3C18
14-22.	Oxygen Cylinder and Regulator Assembly	3C18
14-23.	Oxygen Pressure Gauge Installation	3C20
14-24.	Air Conditioning System Installation	3C24
14-25.	Test Gauge and Manifold Set	3D5
14-26.	Manifold Set Operation	3D6
14-27.	Leak Test Hookup	3D7
14-28.	Evacuation Hookup	3D9
14-29.	Charging Stand	3D11
14-30.	Charging Hookup	3D12
14-31.	Top Dead Center Casting Mark (Sankyo Compressor)	3D15
14-32.	Rotation of Clutch Front Plate (Sankyo Compressor)	3D15
14-33.	Condenser Air Scoop Installation	3D19
14-34.	Expansion Valve	3D20
14-35.	Components Installation	3D22
14-36.	Air Conditioning Wiring Schematic (Early Models)	3E1
14-37.	Synchrophaser Wiring Schematic Auto Synch/ Manual Switch	3E11
14-37a.	Synchrophaser Wiring Schematic (Phase Adjustment Switch)	3E12
14-38.	Engine Synchrophaser Installation	3E13
14-39.	Pulse Generator Installation	3E15

PIPER SENECA II SERVICE MANUAL

LIST OF TABLES

Table		Aerofiche Grid No.
II-I.	Leading Particulars and Principal Dimensions.....	1A21
II-II.	Recommended Torque Values.....	1B2
II-IIA.	Flare Fitting Torque Chart	1B4
II-IIB.	Thread Lubricants.....	1B4
II-III.	Conversion Tables.....	1C8
	Chart A. Inches to Millimeter	1C9
	Chart B. Fraction/Decimal Conversions	1C11
	Chart C. Centigrade/Fahrenheit Conversion Table	1C12
	Chart D. English Vs. Metric.....	1C13
	Chart E. Decimal/Millimeter Equivalents of Drill Sizes from 1/2" to No. 80	1C14
II-IV.	List of Consumable Materials	1C15
III-I.	Inspection Report	1D2
IV-I.	Maximum Distances Between Fluid Tubing Supports	1D19
IV-II.	Maximum Resistance Values Allowed for Electrical Bonding.....	1D19
IV-III.	List of Materials (Thermoplastic Repair)	1F7
IV-IV.	Balance Specifications.....	1F17
V-I.	Control Surface Travels and Cable Tensions	1F23
V-II.	Cable Tension Vs. Ambient Temperature	1F24
V-III.	Troubleshooting Chart (Surface Controls)	1H17
VI-I.	Leading Particulars, Hydraulic Pump	1I12
VI-II.	Characteristics, Hydraulic Pump Motor	1I12
VI-III.	Troubleshooting Chart (Hydraulic System)	1I22
VII-I.	Nose Gear Service Tolerances	1J12
VII-II.	Main Gear Service Tolerances.....	1K7
VII-III.	Toe-In — Toe-Out Correction Chart	1K15
VII-IV.	Troubleshooting Chart (Landing Gear)	1L15
VIII-I.	Propeller Specifications	2A18
VIII-II.	Propeller Chamber Pressure Requirements.....	2A18
VIII-III.	Engine Data	2A21
VIII-IV.	Fuel Flow Vs. Engine Speed	2C17
VIII-V.	Metered Fuel Assembly Calibration.....	2C18
VIII-VI.	Limits - Fuel Flow Vs. Brake H.P.	2C19
VIII-VII.	Troubleshooting Chart (Engine)	2C20
IX-I.	Fuel Quantity Sender Gauge Tolerances	2D20
IX-II.	Fuel Gauge Reading Tolerances	2E4
IX-III.	Gauge Readings/Resistance With Fuel in Tanks.....	2E5
IX-IV.	Troubleshooting Chart (Fuel System)	2E6
X-I.	Gyro Pressure System.....	2E12
X-II.	Directional Gyro Indicator	2E20
X-III.	Gyro Horizon Indicator	2E21
X-IV.	Rate of Climb Indicator	2E22
X-V.	Altimeter.....	2E23

Revised: 3/16/81

1A11

PIPER SENECA II SERVICE MANUAL

LIST OF TABLES (cont.)

Table	Aerofiche Grid No.
X-VI. Airspeed Tubes and Indicator	2F1
X-VII. Magnetic Compass	2F2
X-VIII. Manifold Pressure Indicator	2F5
X-IX. Tachometer	2F6
X-X. Engine Oil Pressure Gauge	2F7
X-XI. Turn and Bank Indicator	2F8
X-XII. Fuel Quantity Indicators	2F9
X-XIII. Oil Temperature Indicators	2F10
X-XIV. Exhaust Gas Temperature Gauge	2F13
X-XV. Cylinder Head Temperature Gauge	2F14
X-XVI. Fuel Flow Gauge	2F14
X-XVII. Instrument Markings	2F15
XI-I. Index to Electrical Schematics	2F18
XI-II. Alternator Specifications	2G8
XI-III. Starting Motor Specifications	2G21
XI-IV. Hydrometer Reading and Battery Charge Percent	2G23
XI-V. Troubleshooting Chart (Electrical System)	2H8
XI-VI. Lamp Replacement Guide	2H20
XI-VII. Electrical Wire Coding	2H21
XI-VIII. Electrical Symbols	2H22
XI-IX. Electrical System Component Loads	2H23
XIII-I. Inspection	2K5
XIII-II. Troubleshooting Chart (Janitrol Heater)	2L10
XIV-I. Required Materials for Repair of Propeller Deicer	3B3
XIV-II. Mixing of Materials	3B5
XIV-III. Electrical Resistance	3B7
XIV-IV. Troubleshooting Chart (Propeller Deicer System)	3B9
XIV-V. Operating Pressures	3B21
XIV-VI. Materials and Supplies for Cold Repair	3B24
XIV-VII. Troubleshooting Chart (Pneumatic Deicer System)	3C7
XIV-VIII. Oxygen System Components Limits	3C13
XIV-IX. Troubleshooting Chart (Oxygen System)	3C21
XIV-X. Temperature Pressure Chart	3D1
XIV-XI. Aluminum Tubing Torque	3D4
XIV-XII. Blower System Wire Color Codes	3D24
XIV-XIII. Troubleshooting Chart (Air Conditioner)	3E2

SECTION I

INTRODUCTION

Paragraph		Aerofiche Grid No.
1-1.	General	1A14
1-2.	Scope of Manual	1A14
1-3.	Description	1A14
1-4.	Wing	1A14
1-5.	Empennage	1A14
1-6.	Fuselage	1A14
1-7.	Landing Gear	1A14
1-8.	Brake System	1A14
1-9.	Engines and Propeller	1A15
1-10.	Fuel System	1A15
1-11.	Flight Controls	1A15
1-12.	Radio	1A15
1-13.	Cabin Heater, Defroster and Fresh Air System	1A15
1-14.	Instrument and Autopilot System	1A15

Reissued: 10/11/79

1 A13

SECTION I

INTRODUCTION

1-1. **GENERAL.** This manual contains service and maintenance instructions for the Piper PA-34-200T Seneca II, designed and manufactured as a versatile airplane in the personal and business aviation field, by the Piper Aircraft Corporation, Vero Beach, Florida.

1-2. **SCOPE OF MANUAL.** Sections II and III comprise the service part of this manual; whereas, Sections IV through XIV comprise the maintenance instructions. The service instructions include ground handling, servicing and inspection. The maintenance instructions for each system include troubleshooting, removal and installation of components, and corrective maintenance and testing; each major system of the airplane is covered in a separate section. Only qualified personnel should perform the operations described in this manual.

The description of the airplane included in this section is limited to general information. Section II gives leading particulars and principal dimensions, along with ground handling, while each major system is described in its appropriate section of the manual. For a more detailed description of the airplane, refer to the Owner's Handbook.

1-3. **DESCRIPTION.** The Seneca II is a six place (seventh seat optional), twin engine, low-wing monoplane of all metal construction. The following paragraphs provide descriptions of the major components and systems.

1-4. **WING.** The laminar flow wing is of all metal stressed-skin, full cantilever, low-wing design, consisting of two wing panels bolted to a spar box assembly in the fuselage. The wing tips are removable. The ailerons are cable and push rod controlled and are aero dynamically balanced. The trailing edge wing flaps are manually operated.

1-5. **EMPENNAGE.** The empennage consists of the fin, rudder, rudder trim tab, stabilator and stabilator trim tabs. The rudder and stabilator are statically balanced.

1-6. **FUSELAGE.** The fuselage consists of three basic units: the nose section, the cabin section and the sheet-metal tail cone.

1-7. **LANDING GEAR.** The tricycle landing gear is of the retractable air-oil strut type, consisting of a nose wheel and two main wheels.

1-8. **BRAKE SYSTEM.** The standard brake system is operated hydraulically by dual toe brakes located on the rudder pedals or by a hand lever connected to a single brake cylinder below and behind the left center of the instrument panel.

PIPER SENECA II SERVICE MANUAL

1-9. **ENGINES AND PROPELLER.** The airplane is powered by two Teledyne Continental six cylinder, direct drive, wet sump, horizontally opposed turbocharged engines. The left engine rotation is in the right-hand direction while the right engine rotates in the left-hand direction. The propellers are Hartzell full feathering, constant speed units controlled by a governor mounted on each engine.

1-10. **FUEL SYSTEM.** The fuel system consists of two interconnected aluminum fuel tanks in each wing, having a combined capacity of 49 U.S. gallons, for a total capacity of 98 U.S. gallons. With optional fuel tanks, each wing will have a combined capacity of 64 U.S. gallons, for a total capacity of 128 U.S. gallons. Incorporated in the system are selector valves, gascolators, and electric priming fuel pumps and engine driven pumps.

1-11. **FLIGHT CONTROLS.** The flight controls are conventional equipment, consisting of a control wheel which operates the ailerons and stabilator, and pedals which operate the rudder. Duplicate controls are provided for the copilot. Trim controls are provided for the rudder and stabilator.

1-12. **RADIO.** Provisions are provided for the installations of microphone and headset jacks, loudspeaker, and panel space for radios and various avionic equipment.

1-13. **CABIN HEATER, DEFROSTER AND FRESH AIR SYSTEM.** Heated air for the cabin and defroster is obtained from the combustion heater located in the tail cone. Fresh air is supplied to the heater from an intake located in the dorsal fin. The combustion heater has a blower which is used to circulate heated or unheated air through six adjustable outlets. There is a defroster blower in the same distribution system to provide additional defrost capability when required. There are six overhead fresh air vents supplied by a separate inlet in the dorsal fin. This system can be supplemented by an optional blower.

1-14. **INSTRUMENT AND AUTOPILOT SYSTEM.** Provisions for instrument installation include panels for engine instruments and advanced instruments, as well as for an Autopilot system.

SECTION II

HANDLING AND SERVICING

Paragraph	Aerofiche Grid No.
2-1. Introduction	1A18
2-2. Dimensions	1A18
2-3. Station Reference Lines	1A18
2-4. Weight and Balance Data	1A18
2-5. Serial Number Plate	1A18
2-6. Access and Inspection Provisions	1A18
2-7. Tools and Test Equipment	1A18
2-8. Torque Requirements	1A24
2-8a. Torque Wrenches	1B1
2-9. Step, Handhold and Walkways	1B7
2-10. Ground Handling	1B7
2-11. Introduction to Ground Handling	1B7
2-12. Jacking	1B7
2-13. Weighing	1B8
2-14. Leveling	1B8
2-15. Mooring	1B9
2-16. Locking Airplane	1B9
2-17. Parking	1B10
2-18. Towing	1B10
2-19. Taxiing	1B10
2-20. External Power Receptacle	1B11
2-21. Operation of External Power Receptacle	1B11
2-22. Servicing	1B11
2-23. Introduction to Servicing	1B11
2-24. Fuel System	1B11
2-25. Servicing Fuel System	1B11
2-26. Filling Fuel Tanks	1B11
2-27. Handling of Moisture in Fuel System	1B12
2-28. Draining Fuel System	1B12
2-29. Brake System	1B13
2-30. Servicing Brake System	1B13
2-31. Filling Brake Cylinder Reservoir	1B13
2-32. Draining Brake System	1B13
2-33. Oleo Struts	1B13
2-34. Servicing Oleo Struts	1B13
2-35. Filling Nose Gear Oleo Strut	1B15
2-36. Filling Main Gear Oleo Struts	1B17
2-37. Inflating Oleo Struts	1B19
2-38. Servicing Steering Bungees	1B19

Revised: 8/10/80

Paragraph

Aero
Grid No.

2-39.	Tires	1B19
2-40.	Servicing Tires	1B19
2-41.	Hydraulic System	1B19
2-42.	Servicing Hydraulic System	1B19
2-43.	Servicing Hydraulic Pump/Reservoir	1B20
2-44.	Battery	1B20
2-45.	Servicing Battery	1B20
2-46.	Cleaning	1B20
2-47.	Cleaning Engine Compartments	1B20
2-48.	Cleaning Landing Gear	1B21
2-49.	Cleaning Exterior Surfaces	1B21
2-50.	Cleaning Windshield and Windows	1B21
2-51.	Cleaning Headliner, Side Panels and Seats	1B21
2-52.	Cleaning Carpets	1B22
2-53.	Lubrication	1B22
2-54.	Oil System (Engine)	1B22
2-55.	Servicing Oil System	1B22
2-56.	Filling Oil Sump	1B22
2-57.	Draining Oil Sump	1B22
2-58.	Oil Screen (Suction)	1B22
2-59.	Oil Filter (Full Flow)	1B22
2-60.	Recommendations for Changing Oil	1B23
2-61.	Lubrication Instructions	1B23
2-62.	Application of Oil	1B24
2-63.	Application of Grease	1B24
2-64.	Lubrication Chart	1B24

NOTE

This chapter contains the Conversion Tables. For ease of use they are also indexed herein.

CHART A.	Inches to Millimeters	1C9
CHART B.	Fraction/Decimal Conversions	1C11
CHART C.	Centigrade/Fahrenheit Conversions	1C12
CHART D.	English Vs. Metric	1C13
CHART E.	Decimal/Millimeter Equivalents of Drill Sizes from 1/2" to No.80	1C14

Revised: 8/10/80

1 A17

SECTION II

HANDLING AND SERVICING

2-1. **INTRODUCTION.** This section contains routine handling and servicing procedures that are most frequently encountered. Frequent reference to this section will aid the individual by providing information such as the location of various components, ground handling procedures, routine service procedures and lubrication. When any system or component requires service other than the routine procedures as outlined in this section, refer to the appropriate section for that component.

2-2. **DIMENSIONS.** The principal airplane dimensions are shown in Figure 2-1 and are listed in Table II-I.

2-3. **STATION REFERENCE LINES.** In order to facilitate the location of various components of the airplane which require maintenance and servicing, a method utilizing fuselage station, wing station or buttock line (BL), and waterline (WL) designations is frequently employed in this manual. (Refer to Figure 2-2.) Fuselage stations, buttock lines, and waterlines are reference points measured by inches in the vertical or horizontal direction from a given reference line which indicates station locations of structural members of the airplane.

2-4. **WEIGHT AND BALANCE DATA.** When figuring various weight and balance computations, the empty, static and gross weight, and center of gravity of the airplane may be found in the Weight and Balance Form of the Airplane Flight Manual.

2-5. **SERIAL NUMBER PLATE.** The serial number plate is located on the left side of the fuselage near the leading edge of the stabilator. The serial number should always be used when referring to the airplane on service or warranty matters.

2-6. **ACCESS AND INSPECTION PROVISIONS.** The access and inspection provisions for the airplane are shown in Figure 2-3. The component to be serviced or inspected through each opening is identified in the illustration. All access plates and panels are secured by either metal fasteners or screws. To enter the aft section of the fuselage, remove the rear baggage compartment upholstery panel by removing the attachment screws.

CAUTION

Before entering the aft section of the fuselage, be sure the airplane is supported at the tail skid.

2-7. **TOOLS AND TEST EQUIPMENT.** Because of the simplicity and easy accessibility of components, few special tools outside normal shop tools will be required. Tools that are required may be fabricated from dimensions given in the back of the section that pertains to a particular component or are listed in the back of the PA-34-200T Parts Catalog.

• PIPER SENECA II SERVICE MANUAL

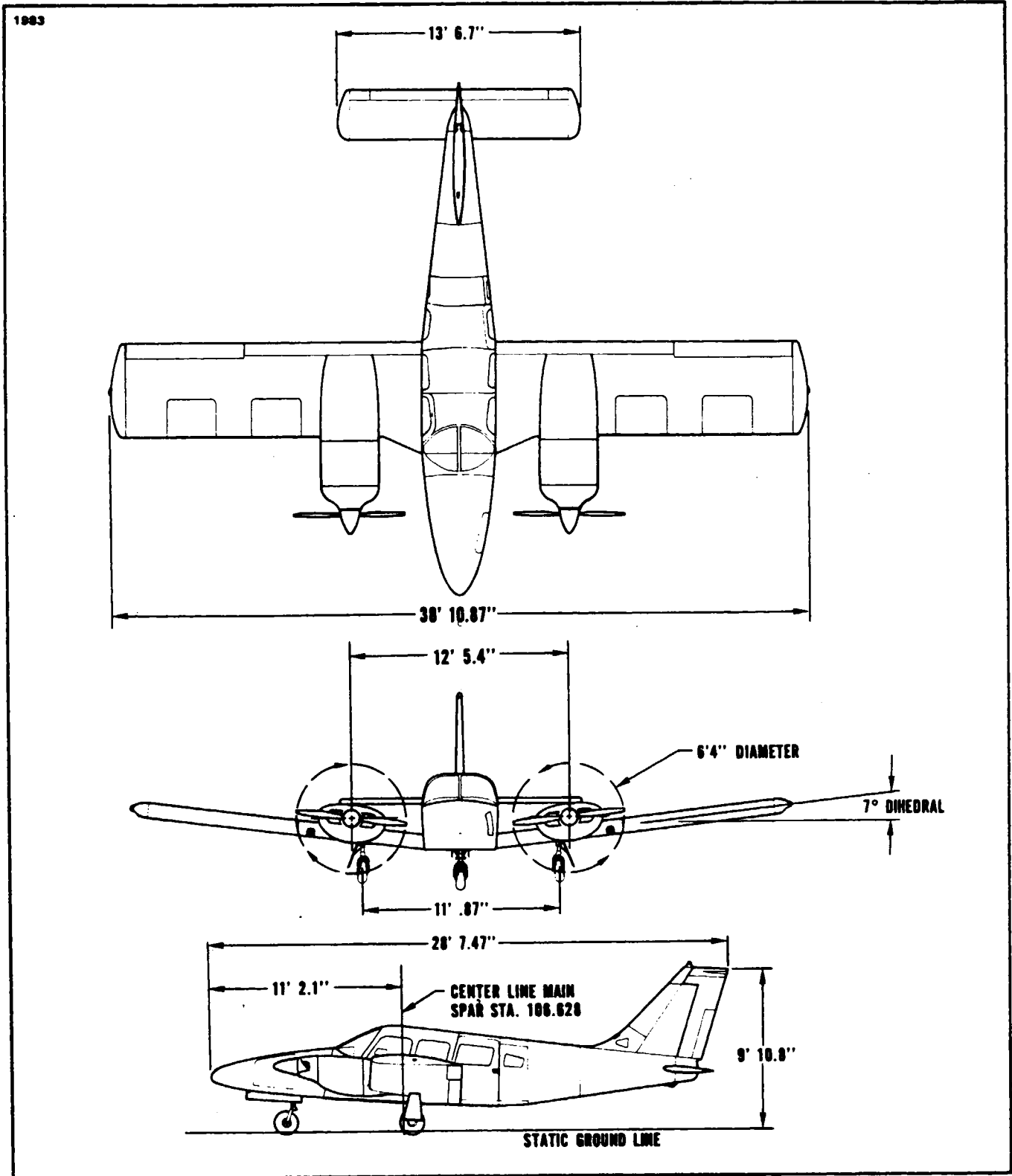

Figure 2-1. Three View

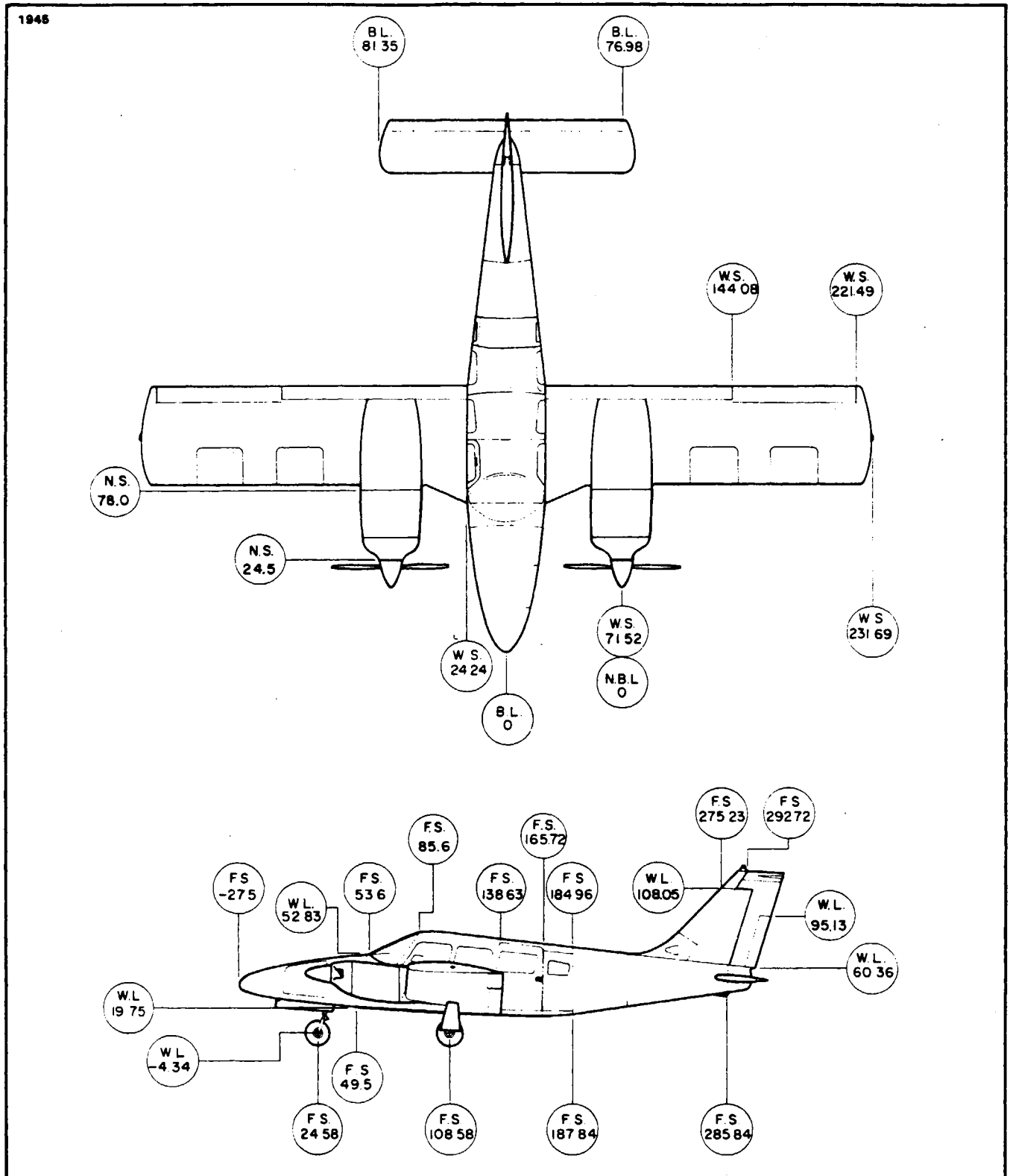

Figure 2-2. Station References

Reissued: 10/11/79

1A20

HANDLING AND SERVICING

TABLE II-I. LEADING PARTICULARS AND PRINCIPAL DIMENSIONS

MODEL	PA-34-200T SENECA II
ENGINE	
Manufacturer	Continental
Model - Left	TSIO-360E-1A (CW) or TSIO-360-EB ⁽¹⁾
Model - Right	LTSIO-360E-1A (CCW) or LTSIO-360-EB ⁽¹⁾
FAA Type Certificate	E9CE
Rated Horsepower (Max. Continuous, Sea Level)	200
Rated Speed	2575 RPM
Oil, SAE Number	See Lubrication Chart
Oil Sump Capacity	8 U.S. quarts
Fuel, Aviation Grade, Minimum Octane	100/130
Fuel Injector	Continental
Magnetos, Scintilla: ⁽¹⁰⁾	
Left (Left Engine)	10-79020-18L
Right (Left Engine)	10-79020-19R
Left (Right Engine)	10-79020-18L
Right (Right Engine)	10-79020-19R
Magneto Timing	20° BTC
Magneto Point Clearance	.018
Spark Plugs (Shielded):	Refer to latest revision of Teledyne Continental Aircraft Engine Service Bulletin M77-10
 Spark Plug Gap Setting	 Refer to latest revision of Teledyne Continental Aircraft Engine Service Bulletin M77-10
Firing Order:	
Left Engine	1-6-3-2-5-4
Right Engine	1-4-5-2-3-6
Starter - Prestolite (12-volt):	
Left Engine	MCL-6501
Right Engine	MCL-6501
Alternator - Prestolite (65 amp)	ALX 9425
Alternator Voltage Regulator, LAMAR	B-00288-1
Alternator Overvoltage Relay, WICO	X-16799B

(1) REPLACEMENT ENGINE ON AIRCRAFT MODELS WITH SERIAL NUMBERS PA-34-7570001 AND UP.
 (10) MAY BE PRESSURIZED IF KIT NO. 764 921V IS INSTALLED.

TABLE II-I. LEADING PARTICULARS AND PRINCIPAL DIMENSIONS (cont)

PROPELLER

	Hartzell	McCauley
Manufacturer		
Hub, Model:		
Left Engine	BHC-C2YF-2CKF ⁽²⁾	3AF34C502
Right Engine	BHC-C2YF-2CLKF ⁽²⁾	3AF34C503
Alternate Hub, Models:	BHC-C2YF-2CKUF (Left Eng.) ⁽²⁾ BHC-C2YF-2CLKUF (Right Eng.) ⁽²⁾	
Blade, Model:		
Left Engine	FC8459-8R & FC8459B-8R	80HA-4
Right Engine	FJC8459-8R & FJC8459B-8R	L80HA-4
Diameter	76 in.	76 in.
Diameter, Minimum	75 in.	75 in.
Blade Angle, Low Pitch (High RPM)	14.4° ± 0.2°	12.2° ± 0.2° ⁽⁷⁾ or 11.5° ± 0.2° ⁽⁸⁾ Up to S/N 34-7870492 (inclusive)
Blade Angle, High Pitch (Low RPM)	79.3° ± 2.0° ⁽⁴⁾ or 80° to 81.5° ^{(4) (5)}	12.0° ± 0.2° S/N 34-7970001 (inclusive) and up ⁽⁹⁾ 81° to 83.5°
Governor Control	Woodward	
Governor Model:		
Left Engine	C210659	
Right Engine	210C58	
Alternate Governor Model:	Hartzell	
Left Engine	E-3	
Right Engine	E-3L	
Right Engine When Synchrophaser is installed	49E-8L	

FUEL SYSTEM

Fuel Tank	49 gal./wing	64 gal./wing ⁽³⁾
Total Capacity (Both Wings)	98 gal.	128 gal. ⁽³⁾
Total Usable Fuel	93 gal.	123 gal. ⁽³⁾

(2) PROPELLERS TO BE MOUNTED IN PAIRS ONLY. DO NOT MIX WITH OTHER PROPELLERS.

(3) WITH OPTIONAL FUEL TANKS INSTALLED.

(4) ON PROPELLER HUBS WITH SERIAL NUMBERS PRIOR TO AN3943, EITHER SETTING IS APPROPRIATE AT OWNER'S DISCRETION.

(5) ON PROPELLER HUBS WITH SERIAL NUMBERS AN3943 AND SUBSEQUENT ONLY THIS SETTING CAN BE USED.

(7) LEFT ENGINE ONLY.

(8) RIGHT ENGINE ONLY.

(9) BOTH ENGINES

TABLE II-I. LEADING PARTICULARS AND PRINCIPAL DIMENSIONS (cont.)

LANDING GEAR

Type	Fully Retractable	
Shock Strut Type	Air-Oil Oleo	
Fluid Required (Struts, Brakes & Hydraulic System)	MIL-H-5606	
Strut Exposure (Exposure under Static load):		
Nose	2.60 ± .25 in.	
Main	3.60 ± .25 in.	PPS400250
Wheel Tread	11.1 ft.	
Wheel Base	7 ft.	
Nose Wheel Travel	27° left, 27° right	
Wheel, Nose	Cleveland 38501, 6:00 x 6	
Wheel, Main	Cleveland 40-56B 6:00 x 6 Cleveland 40-90 6:00 x 6 Cleveland 40-120 6:00 x 6 Heavy Duty Cleveland 30-65 or 30-83 ⁽⁶⁾	
Brake Type		
Tires, Nose	6:00 x 6 (6 ply) or Nylon-T.T. Type III ⁽⁶⁾	
Tires, Main	6:00 x 6 (8 ply) or Nylon-T.T. Type III ⁽⁶⁾	
Tire Pressure, Nose	31 psi @ Gross Weight, 34 psi ⁽⁶⁾	PPS400254
Tire Pressure, Main	55 psi @ Gross Weight, 46 psi ⁽⁶⁾	78757C

CONTROL SURFACES

Refer to Section V

CABLE TENSIONS

Refer to Section V

(6) PA-34-200T MODEL WITH HEAVY DUTY BRAKES, WHEELS AND EITHER B.F. GOODRICH NYLON-T.T. TYPE III TIRES OR McCREARY AIR HAWK TYPE III. (REFER TO PIPER KIT NO. 761 048 V.)

2-8. TORQUE REQUIREMENTS. Proper torque application cannot be overemphasized. Undertorqued assemblies can result in premature failure due to fatigue from uneven loads, as well as causing unnecessary wear of nuts, bolts, and other parts. Overtorqued assemblies can be equally harmful by causing failure of a bolt or nut by overstressing the threaded areas.

The torque values given in Table II-II are derived from oil-free cadmium-plated threads and are recommended for all airframe installation procedures where torquing is required, unless otherwise noted in sections where other values are stipulated. Engine torque values are found in the latest revision of Teledyne Continental Overhaul Manual, and propeller torque values are found in Section VIII of this manual. Table II-IIA lists the torque values for flared fittings of various sizes and material. Important procedures for torquing assemblies on Piper Aircraft are as follows:

- a. Frequently check and/or calibrate the torque wrench.
- b. **MAKE SURE** bolt/screw and nut threads are clean and dry, unless otherwise required. If the threads are to be lubricated and no torque is specified, reduce recommended *nut* torque (plus the friction drag torque) by 50%.
- c. Unless otherwise specified the charted torque values should be used. Should a bolt or nut be listed and not its mating fastener, use the lower torque.
- d. When using "self-locking fasteners" and hardware with thread sizes 8 through 7/16 add the specified friction drag torque to the designated torque. Assume a friction drag torque of zero for non self-locking fasteners. For other bolt sizes the friction drag torque is determined as follows:
 1. Turn nut to "near contact" with the bearing surface (**NOT IN CONTACT**).
 2. Attach a scale type torque wrench and determine the torque required to turn the nut on the bolt before it contacts the bearing surface. Add this value to the specified torque for the total torque value to be applied.
- e. When torquing castellated nuts remember the following:
 1. Determine total torque value (friction torque - if any - plus max. torque) and do not exceed when aligning slot and hole, change washers if necessary.
 2. Tighten nuts only to remove looseness in the joint before installing cotter pin.
- f. Use the latest information from CONTINENTAL for torquing powerplant parts.
- g. On critical installations the nut should be permanently marked red after torquing and not be further tightened or disturbed.

NOTE

When flared fittings are being installed, ascertain that the male threads are properly lubricated. Torque the fittings in accordance with Table II-IIA. For more details on torquing, refer to FAA Manual AC 43-13-1A.

CAUTION

Do not overtorque fittings.

2-8A. TORQUE WRENCHES.

Torque wrenches should be checked daily and calibrated by means of weights and a measured lever arm to make sure that inaccuracies are not present. Checking one torque wrench against another is not sufficient and is not recommended. Some wrenches are quite sensitive as to the way they are supported during a tightening operation. Any instructions furnished by the manufacturer must be followed explicitly.

When it is necessary to use a special extension or adapter wrench together with a torque wrench, a simple mathematical equation must be worked out to arrive at the correct torque reading. Following is the formula to be used: (Refer to Figure 20-5.)

T = Torque desired at the part.

A = Basic lever length from center of wrench shank to center of handle. This may be stamped on the wrench itself or it may be listed elsewhere.

B = Length of adapter extension, center of bolt to center of shank.

C = Scale reading needed to obtain desired torque (T).

$$\text{The formula: } C = \frac{A \times T}{A + B}$$

EXAMPLE

A bolt requires 30 foot-pounds and a 3 inch adapter (one-quarter of a foot or .25') is needed to get at it. You want to know what scale reading it will take on a one-foot lever arm wrench to obtain the 30 foot-pounds at the bolt.

$$C = \frac{1 \times 30}{1 + .25} \text{ or } C = \frac{30}{1.25} = 24 \text{ ft.-lbs.}$$

Remember, the 3 inch adapter must be projecting 3 inches straight along the wrench axis. In general, avoid all complex assemblages or adapters and extensions of flex joints.

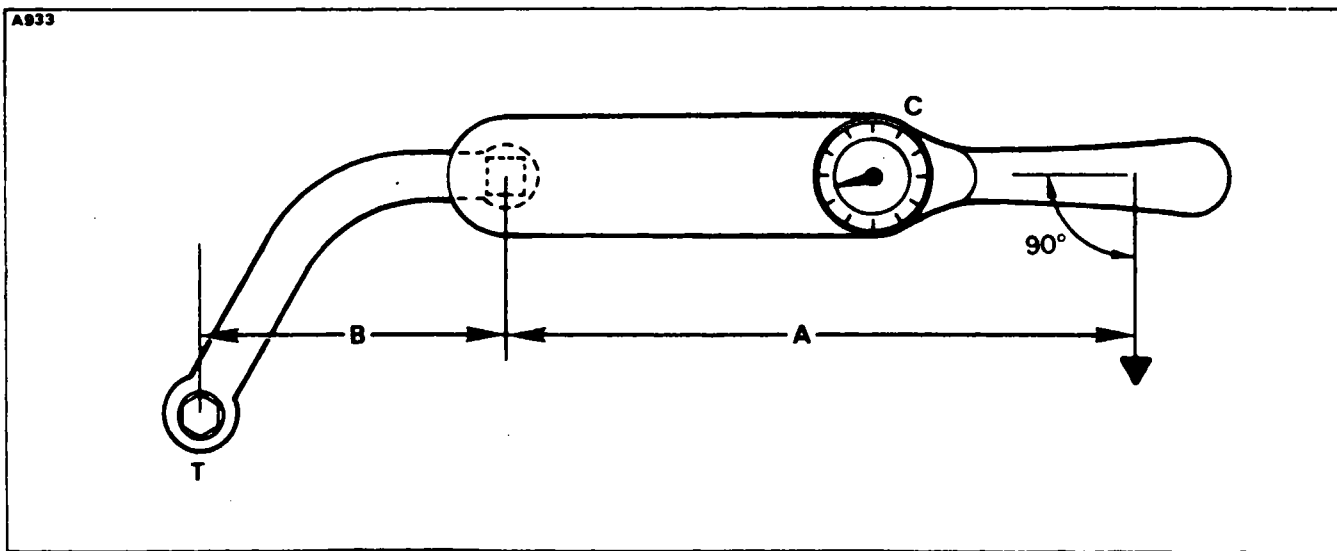

Figure 2-2a. Torque Wrench Formula

Added: 8/10/80

HANDLING AND SERVICING

TABLE II-II. RECOMMENDED TORQUE VALUES

COARSE THREAD SERIES					
BOLTS Steel Tension					
AN 3 thru AN 20 AN 42 thru AN 49 AN 73 thru AN 81 AN 173 thru AN 186 MS 20033 thru MS 20046 MS 20073 MS 20074 AN 509 NK9 MS 24694 AN 525 NK525 MS 27039					
NUTS					
Steel Tension			Steel Shear		
AN 310 AN 315 AN 363 AN 365 NAS 1021 MS 17825 MS 21045 MS 20365 MS 20500 NAS 679			AN 320 AN 364 NAS 1022 MS 17826 MS 20364		
Nut-bolt size	Torque Limits in-lbs		Torque Limits in-lbs		
	Min.	Max.	Min.	Max.	
8 -32	12	15	7	9	
10 -24	20	25	12	15	
1/4-20	40	50	25	30	
5/16-18	80	90	48	55	
3/8-16	160	185	95	110	
7/16-14	235	255	140	155	
1/2-13	400	480	240	290	
9/16-12	500	700	300	420	
5/8-11	700	900	420	540	
3/4-10	1,150	1,600	700	950	
7/8-9	2,200	3,000	1,300	1,800	
1 -8	3,700	5,000	2,200	3,000	
1-1/8-8	5,500	6,500	3,300	4,000	
1-1/4-8	6,500	8,000	4,000	5,000	

NOTE

WHERE NORMAL OPERATION REQUIRES MOVEMENT BETWEEN COMPONENTS BEING BOLTED OR CLAMPED TOGETHER, THE HARDWARE SHOULD BE TIGHTENED AS REQUIRED OR SPECIFIED, DISREGARDING THE TORQUE CHART(S).

USE THE LOWER SIDE OF THE TORQUE RANGE WHERE THE BOLT IS FIXED AND THE NUT MOVEABLE.

USE THE HIGHER SIDE OF THE TORQUE RANGE WHERE THE NUT IS FIXED AND THE BOLT MOVEABLE.

FRICITION DRAG TORQUES
COARSE AND FINE

BOLT SIZE	FRICITION DRAG TORQUE (IN -LBS)
8 (coarse)	15
10	18
1/4	30
5/16	60
3/8	80
7/16	100

PPS20016G

PPS20016G

TABLE II-II. RECOMMENDED TORQUE VALUES (cont.)

FINE THREAD SERIES													
	BOLTS Steel Tension				BOLTS Steel Tension				BOLTS Aluminum				
	AN 3 thru AN 20 AN 42 thru AN 49 AN 73 thru AN 81 AN 173 thru AN 186 MS 20033 thru MS 20046 MS 20073 MS 20074 AN 509 NK9 MS 24694 AN 525 NK525 MS 27039				MS 20004 thru MS 20024 NAS 144 thru NAS 158 NAS 333 thru NAS 340 NAS 583 thru NAS 590 NAS 624 thru NAS 644 NAS 1303 thru NAS 1320 NAS 172 NAS 174 NAS 517				AN 3DD thru AN 20DD AN 173DD thru AN 186DD AN 509DD AN 525D MS 27039D MS 24694DD				
	NUTS				NUTS				NUTS				
	Steel Tension		Steel Shear		Steel Tension		Steel Shear		Alum. Tension		Alum. Shear		
	AN 310 AN 315 AN 363 AN 365 NAS 1021 MS 17825 MS 21045 MS 20365 MS 20500 NAS 679		AN 320 AN 364 NAS 1022 MS 17826 MS 20364		AN 310 AN 315 AN 363 AN 365 MS 17825 MS 20365 MS 21045 NAS 1021 NAS 679 NAS 1291		AN 320 AN 364 NAS 1022 MS 17826 MS 20364		AN 365D AN 310D NAS 1021D		AN 320D AN 364D NAS 1022D		
Nut-bolt size	Torque Limits in-lbs		Torque Limits in-lbs		Torque Limits in-lbs		Torque Limits in-lbs		Torque Limits in-lbs		Torque Limits in-lbs		
	Min.	Max.	Min.	Max.	Min.	Max.	Min.	Max.	Min.	Max.	Min.	Max.	
8 -36	12	15	7	9					5	10	3	6	
10 -32	20	25	12	15	25	30	15	20	10	15	5	10	
1/4-28	50	70	30	40	80	100	50	60	30	45	15	30	
5/16-24	100	140	60	85	120	145	70	90	40	65	25	40	
3/8-24	160	190	95	110	200	250	120	150	75	110	45	70	
7/16-20	450	500	270	300	520	630	300	400	180	280	110	170	
1/2-20	480	690	290	410	770	950	450	550	280	410	160	260	
9/16-18	800	1,000	480	600	1,100	1,300	650	800	380	580	230	360	
5/8-18	1,100	1,300	660	780	1,250	1,550	750	950	550	670	270	420	
3/4-16	2,300	2,500	1,300	1,500	2,650	3,200	1,600	1,900	950	1,250	560	880	
7/8-14	2,500	3,000	1,500	1,800	3,550	4,350	2,100	2,690	1,250	1,900	750	1,200	
1 -14	3,700	4,500	2,200	3,300	4,500	5,500	2,700	3,300	1,600	2,400	950	1,500	
1-1/8-12	5,000	7,000	3,000	4,200	6,000	7,300	3,600	4,400	2,100	3,200	1,250	2,000	
1-1/4-12	9,000	11,000	5,400	6,600	11,000	13,400	6,600	8,000	3,900	5,800	2,300	3,650	

PPS20015G

Revised: 8/10/80

TABLE II-IIA. FLARE FITTING TORQUE CHART

TORQUE - INCH POUND						
TUBING OD INCHES	ALUMINUM - ALLOY TUBING FLARE-AND 10061 OR AND 10078		STEEL TUBING FLARE AND 10061		HOSE END FITTING AND HOSE ASSEMBLIES	
	MINIMUM	MAXIMUM	MINIMUM	MAXIMUM	MINIMUM	MAXIMUM
1/8	---	---	---	---	---	---
3/16	---	---	90	100	70	100
1/4	40	65	135	150	70	120
5/16	60	80	180	200	85	180
3/8	75	125	270	300	100	250
1/2	150	250	450	500	210	420
5/8	200	350	650	700	300	480
3/4	300	500	900	1000	500	850
1	500	700	1200	1400	700	1150
1-1/4	600	900	---	---	---	---
1-1/2	600	900	---	---	---	---
1-3/4	---	---	---	---	---	---
2	---	---	---	---	---	---

TABLE II-IIB. THREAD LUBRICANTS

TYPE OF LINE	TYPE OF LUBRICANT
Brakes	MIL-H-5606
Freon	TT-A-580 or MIL-T-5544, Anti-Seize Compound
Fuel	MIL-T-5544, Anti-Seize, Graphite Petrolatum
Landing Gear (Air Valve)	6PB Parker
Oil	MIL-G-6032, Lubricating Grease (Gasoline and Oil Resistant)
Pitot and Static	TT-A-580 (JAN-A-669), Anti-Seize Compound (White Lead Base)
<p>NOTE Lubricate engine fittings only with the fluid contained in the particular lines.</p>	

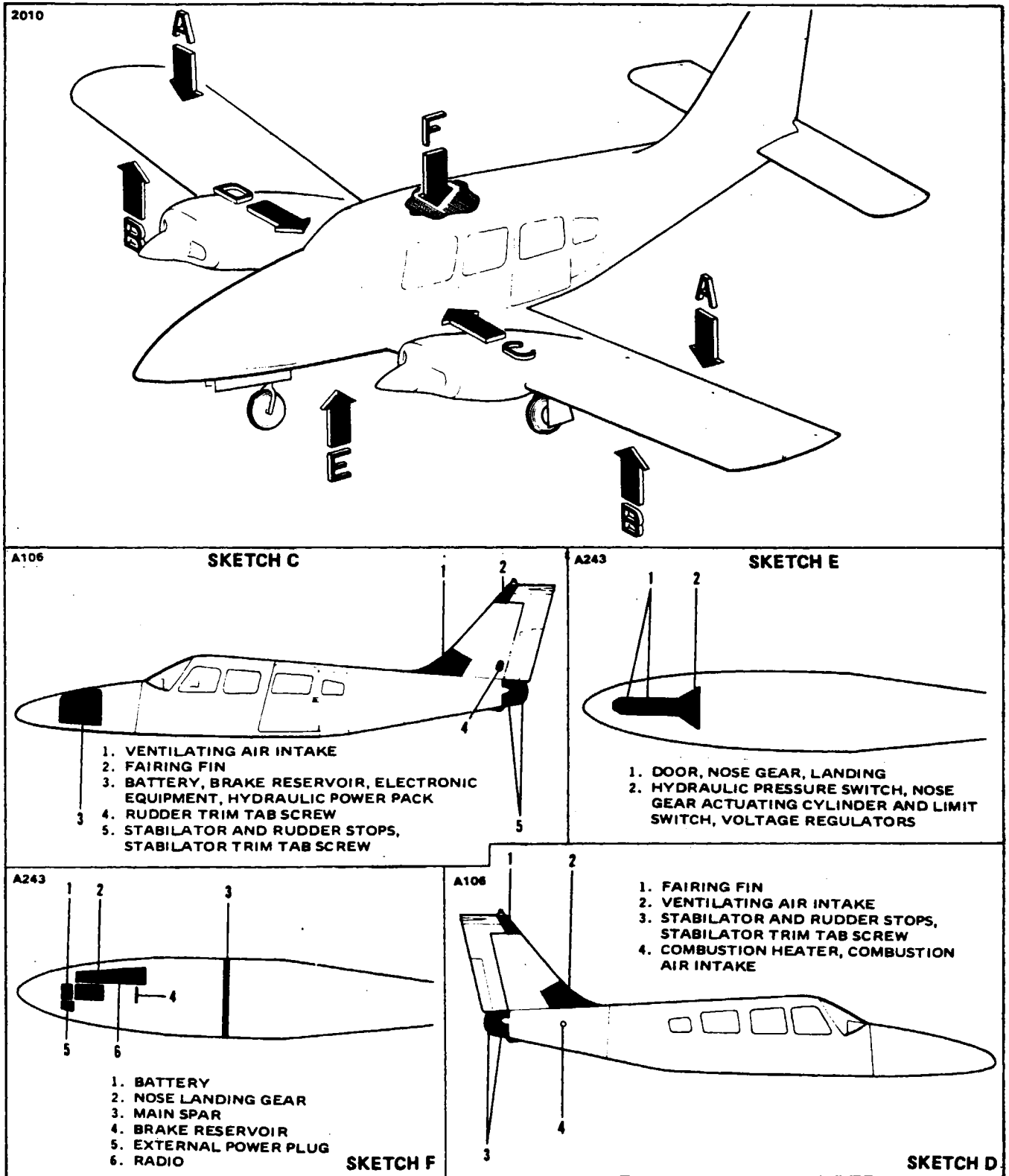

Figure 2-3. Access Plates and Panels

Reissued: 10/11/79

PIPER SENECA II SERVICE MANUAL

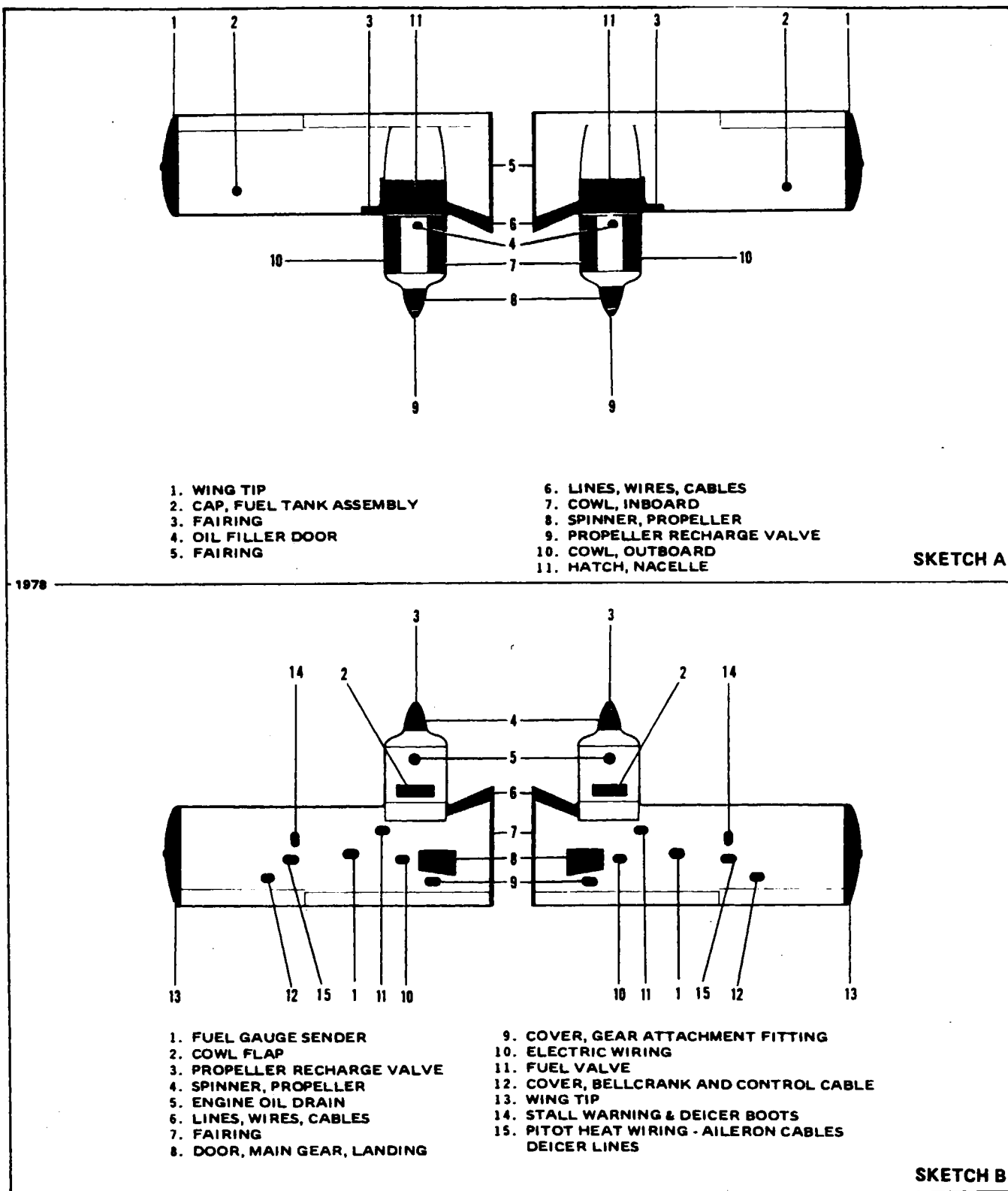

Figure 2-3. Access Plates and Panels (cont.)

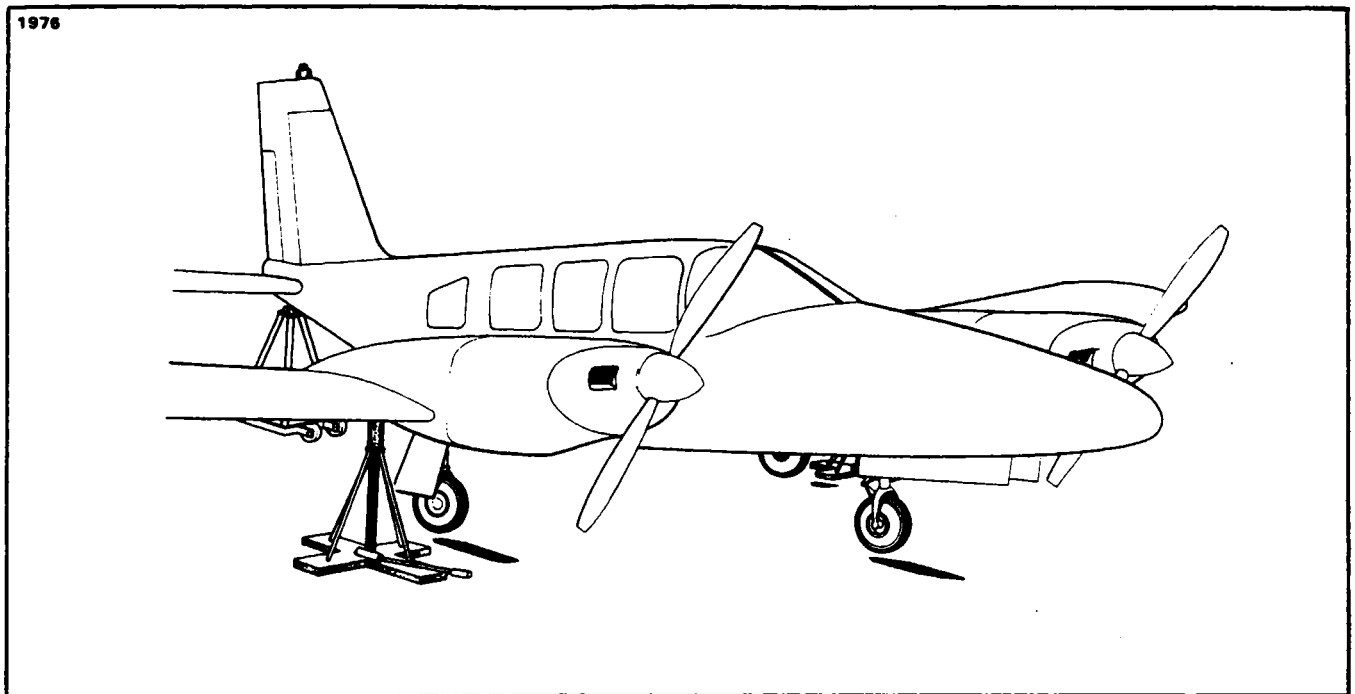

Figure 2-4. Jacking

2-9. **STEP, HANDHOLD AND WALKWAYS.** A fixed handhold is located on the right side of the fuselage, above and aft of the second window. The walkway is made up of a non-skid material which is in turn bonded to the wing surface. (Refer to Section IV for repair or replacement of wing walkway material.)

CAUTION

Walk on the walkways only to avoid damage to the wings.

2-10. **GROUND HANDLING.**

2-11. **INTRODUCTION TO GROUND HANDLING.** Ground handling covers all essential information governing the handling of the airplane while on the ground. This includes jacking, weighing, leveling, mooring, parking, towing and taxiing. When the airplane is handled in the manner described in the following paragraphs, damage to the airplane and its equipment will be prevented.

2-12. **JACKING.** Jack the airplane as specified to perform various service operations. Proceed as follows:

- a. Place the jacks under the jack pads on the wing front spar.
- b. Attach a tail support to the tail skid. Place approximately 600 pounds of ballast on the support to hold the tail down. (Refer to Figure 2-4.)

CAUTION

Be sure to apply sufficient support ballast; otherwise, the airplane will tip forward and fall on the fuselage nose section:

- c. Carefully raise jacks until all three wheels are clear of the surface.

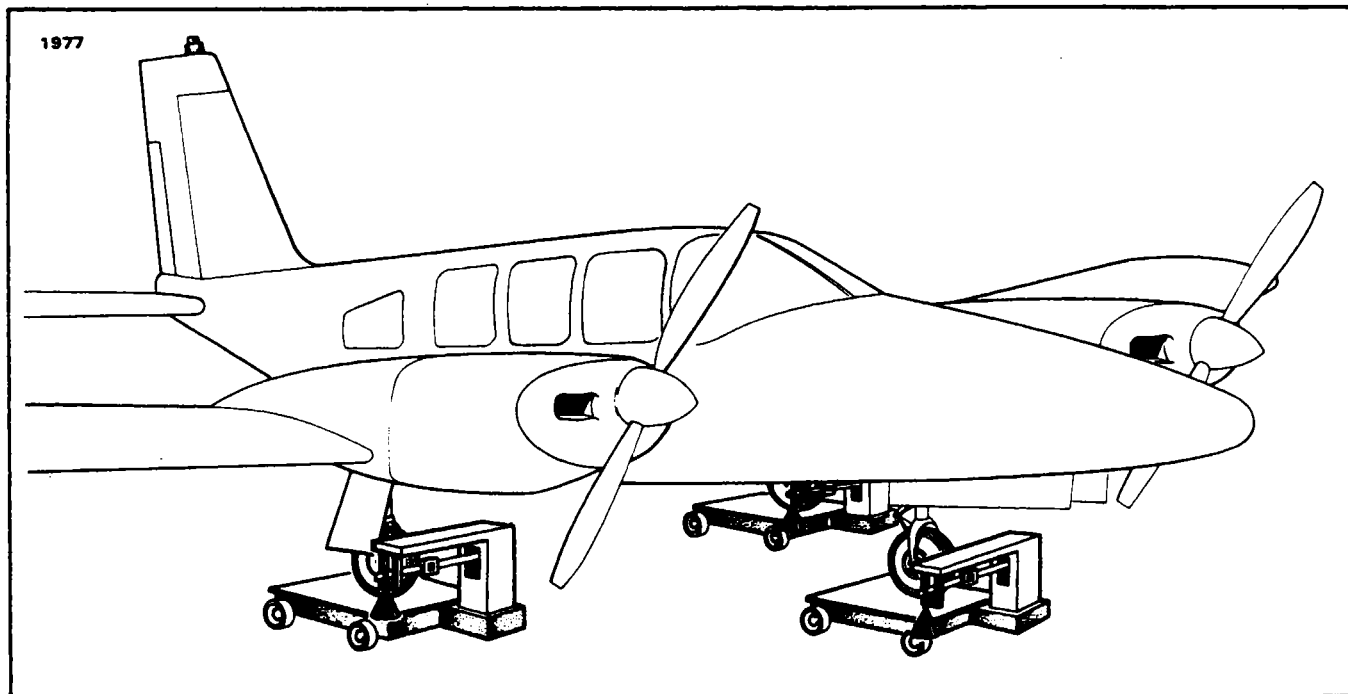

Figure 2-5. Weighing

CAUTION

If the purpose for placing the airplane on jacks is to service the hydraulic system, the free-fall valve knob should be pulled full out from the instrument panel. (Refer to Section VI, Paragraph 6-1.)

2-13. **WEIGHING.** (Refer to Figure 2-5.) The airplane may be weighed by the following procedure:

- a. Position a scale and ramp in front of each of the three wheels.
- b. Secure the scales from rolling forward and tow the airplane up onto the scales. (Refer to Towing, Paragraph 2-18.)
- c. Remove the ramp so as not to interfere with the scales.
- d. If the airplane is to be weighed for weight and balance computations, level the airplane per instructions given in Paragraph 2-14.

2-14. **LEVELING.** All configurations of the airplane are provided with a means for longitudinal and lateral leveling. The airplane may be leveled while on jacks, during the weighing procedure while the wheels are on scales, or while the wheels are on the ground. To level the airplane for purposes of weighing or rigging, the following procedures may be used:

- a. To longitudinally level the airplane, partially withdraw the two leveling screws located immediately below the left front side window. (Refer to Figure 2-6.) Place a spirit level on these screw heads and deflate the nose wheel tire or adjust the jacks until the bubble of the level is centered.
- b. To laterally level the airplane, place a spirit level across the baggage compartment floor along the rear bulkhead (refer to Figure 2-6) and deflate the tire on the high side of the airplane or adjust either jack until the bubble of the level is centered.

A368

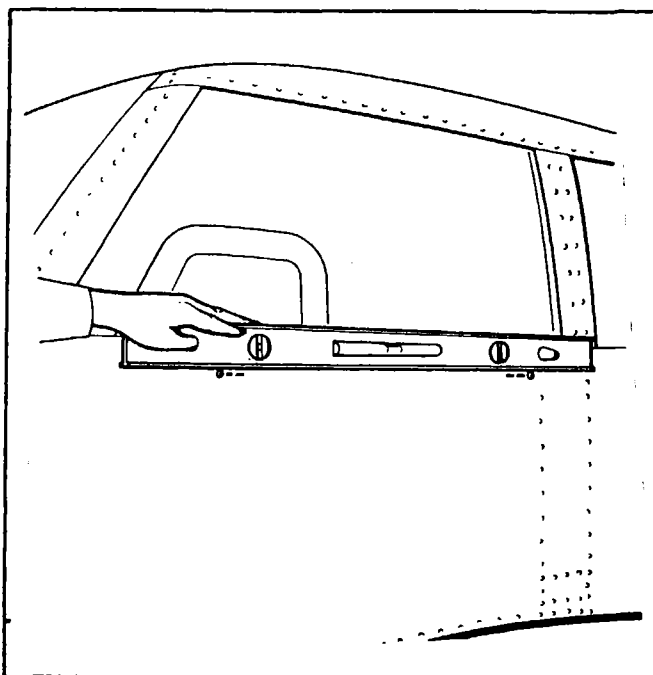

Longitudinally

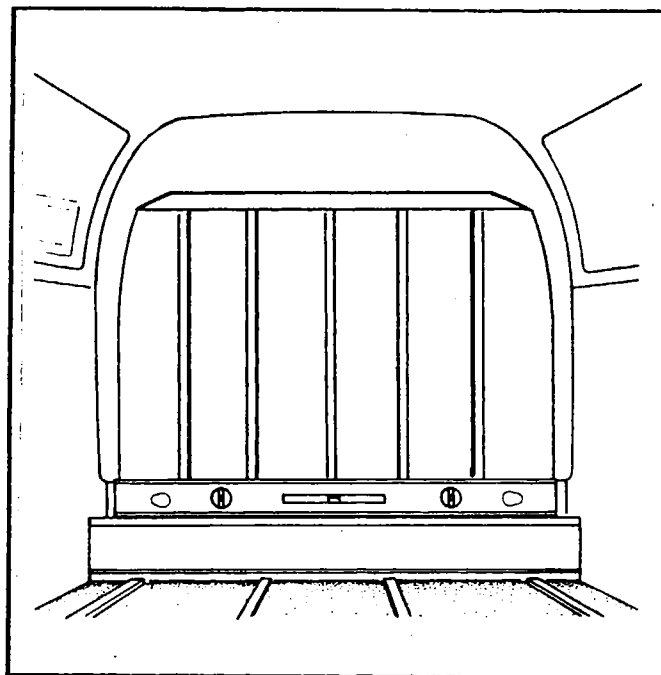

Laterally

Figure 2-6. Leveling Airplane

2-15. MOORING. The airplane is moored to insure its immovability, protection, and security under various weather conditions. The following procedure gives the instructions for proper mooring of the airplane:

- a. Head the airplane into the wind, if possible.
- b. Block the wheels.
- c. Lock the aileron and stabilator controls by looping the pilot's seat belt around wheel.
- d. Secure tie-down ropes to the wing tie-down rings and the tail skid at approximately 45 degree angles to the ground. When using rope constructed of non-synthetic material, leave sufficient slack to avoid damage to the airplane when the ropes contract due to moisture.

CAUTION

Use square or bowline knots. Do not use slip knots.

NOTE

Additional preparations for high winds include using tie-down ropes from the landing gear forks, securing the rudder, and securing the props to prevent windmilling.

2-16. LOCKING AIRPLANE. The right cabin door is provided with a key lock on the outside. The cabin door lock and nose baggage compartment door lock use the same key.

2-17. **PARKING.** When parking the airplane, insure that it is sufficiently protected against adverse weather conditions and presents no danger to other aircraft. When parking the airplane for any length of time or overnight, it is recommended that it be moored as in Paragraph 2-15.

- a. To park the airplane, head it into the wind, if possible.
- b. Set the parking brake by pulling back the brake lever and depressing the knob attached to the left side of the handle. Then release the handle. To release the parking brakes, pull back on the brake lever to disengage the catch mechanism. Then allow the handle to swing forward.

NOTE

Care should be taken when setting brakes that are overheated or during cold weather when accumulated moisture may freeze the brakes.

- c. The aileron and stabilator controls may be secured with the pilot's seat belt.

2-18. **TOWING.** The airplane may be moved by using the nose wheel steering bar that is stowed below the forward ledge of the rear baggage compartment or power equipment that will not damage or cause excess strain to the nose gear steering assembly. Tow bar engages front axle inside fork.

CAUTION

When towing with power equipment, do not turn the nose gear in either direction beyond its steering radius limits as this will result in damage to the nose gear and steering mechanism.

CAUTION

When moving the aircraft forward by hand, avoid pushing on the trailing edge of the ailerons as this will cause the aileron contour to change resulting in an out-of-trim condition.

In the event towing lines are necessary, lines (rope) should be attached to both main gear struts as high up on the tubes as possible. Lines should be long enough to clear the nose and/or tail by not less than 15 feet, and a qualified person to ride in the pilot's seat to maintain control by use of the brakes.

2-19. **TAXIING.** Before attempting to taxi the airplane, ground personnel should be checked out by a qualified pilot or other responsible person. Engine starting and shutdown procedures should be covered as well. When it is ascertained that the propeller back blast and taxi areas are clear, apply power to start the taxi roll and perform the following checks:

- a. Taxi forward a few feet and apply brakes to determine their effectiveness.
- b. Taxi with propellers set in low pitch, high RPM setting.
- c. While taxiing, make slight turns to ascertain the effectiveness of steering.
- d. Observe wing clearances when taxiing near buildings or other stationary objects. If possible, station a guide outside the airplane to observe.
- e. When taxiing on uneven ground, look for and avoid holes and ruts.
- f. Do not operate the engines at high RPM when running up or taxiing over ground containing loose stones, gravel, or any loose material that may cause damage to the propeller blades.

2-20. EXTERNAL POWER RECEPTACLE.

2-21. OPERATION OF EXTERNAL POWER RECEPTACLE. The external power receptacle is located on the left side of the nose section. When using external power for starting or operation of any of the airplane's equipment, the master switch must be ON.

CAUTION

Turn master switch off before inserting or removing plug.

NOTE

When using a 12-volt battery for external power starting and the airplane's battery is nearly depleted, the instructions given in Section XI must be followed.

2-22. SERVICING.

2-23. INTRODUCTION TO SERVICING. Servicing the airplane includes the replenishment of fuel, oil, hydraulic fluid, tire pressures, lubrication requirements, and other items required to completely service the airplane.

2-24. FUEL SYSTEM.

2-25. SERVICING FUEL SYSTEM. At intervals of 50 hours or 90 days, whichever comes first, clean the fuel filter pack. Remove and clean the filters in accordance with the instructions outlined in Section IX. Additional service information may also be found in Section IX. Inspection intervals of the various fuel system components may be found in Section III.

2-26. FILLING FUEL TANKS. The fuel tanks of each wing are filled through a single filler located on the forward slope of the wing at the outboard tank. An anti-icing additive complying with MIL-I-27686 may be added if desired when filling the system (see paragraph 2-27).

With each of the interconnected wing tanks having a capacity of 24.5 gallons, a total capacity of 49 gallons is available per wing, 64 gallons with optional tanks.

CAUTION

Observe all required safety precautions and use the fuel specified on the placard adjacent to the filler neck.

2-27. **HANDLING OF MOISTURE IN FUEL SYSTEM.** Moisture and foreign matter can be drained from drains incorporated in the bottom of the system's lowest point and the inboard end of each fuel tank. To prevent ice contamination an anti-icing additive per MIL-I-27686B may be used *provided* it is uniformly blended with the fuel *while refueling*. The additive must not exceed .15% by volume of the refueled quantity. To be effective the blend should not be less than .10% by volume. A good example would be 1-1/2 liquid ounces per 10 gallons of fuel. For best results, follow the manufacturer's mixing or blending instructions. Refer to list of consumable materials for purchasing information. If possible a blender supplied by the manufacturer should be used.

CAUTION

Make sure that when adding an anti-icing additive it is directed into the flowing fuel stream, starting after and stopping before the fuel flow. **DO NOT** permit the additive to come in contact with painted surfaces or interior surfaces of the tank.

Do not add further blending to pre-blended fuels.

Fuel additive(s) do not substitute for preflight draining of fuel system drains.

2-28. **DRAINING FUEL SYSTEM.** The bulk of the fuel may be drained from the system by opening the valve at the inboard end of each fuel tank. Push up on the arms of the drain valve and turn counterclockwise to hold the drain in the open position. The remaining fuel in the system may be drained through the fuel filters and the two drains located on the lower right side of the fuselage inboard to the flaps.

INTENTIONALLY LEFT BLANK

2-29. BRAKE SYSTEM.

2-30. SERVICING BRAKE SYSTEM. The brake system incorporates a hydraulic fluid reservoir through which the brake system is periodically serviced. Fluid is drawn from the reservoir by the brake cylinders to maintain the volume of fluid required for maximum braking efficiency. Spongy brake pedal action is often an indication that the brake fluid reservoir is running low on fluid. Instructions for filling the reservoir are given in Paragraph 2-31. When found necessary to accomplish repairs to any of the brake system components, or to bleed the system, these instructions may be found in Section VII.

2-31. FILLING BRAKE CYLINDER RESERVOIR. The brake cylinder reservoir should be filled to the level marked on reservoir with the fluid specified in Table II-I. The reservoir, located on the center of the bulkhead in the nose baggage compartment, should be checked at every 50 hour inspection and replenished as necessary. No adjustment of the brakes is necessary, though they should be checked periodically per instructions given in Section VII.

2-32. DRAINING BRAKE SYSTEM. To drain the brake system, connect a hose to the bleeder fitting on the bottom of the cylinder and place the other end of the line in a suitable container. Open the bleeder and slowly pump the hand brake lever and the desired brake pedal until fluid ceases to flow. To drain the wheel brake unit, disconnect the line at the bottom of the unit and allow fluid to flow into a suitable container. To clean the brake system, flush with denatured alcohol.

2-33. OLEO STRUTS.

2-34. SERVICING OLEO STRUTS. The air-oil type oleo strut should be maintained at proper strut piston tube exposures for best oleo action. The nose gear strut must have approximately $2.60 \pm .25$ inches of piston tube exposed, while the main gear strut requires approximately $3.60 \pm .25$ inches of tube exposure. These measurements are taken with the airplane sitting on a level surface under normal static load.

NOTE

Normal static load is the empty weight of the airplane plus full fuel and oil.

CAUTION

Do not exceed these tube exposures.

If the strut has less tube exposure than prescribed, determine whether it needs air or oil by rocking the airplane. If the oleo strut oscillated with short strokes (approximately one inch) and the airplane settles to its normal position within one or two cycles after the rocking force is removed, the oleo strut requires inflating. Check the valve core and filler plug for air leaks, correct if required, and add air or nitrogen as described in Paragraph 2-37. If the oleo strut oscillates with long strokes (approximately three inches) and the airplane continues to oscillate after the rocking force is removed, the oleo struts require fluid. Check the oleo for indications of oil leaks, correct if required, and add fluid as described in Paragraph 2-35 or 2-36. For repair procedures of the landing gear and/or oleo struts, refer to Section VII of this manual.

WARNING

Do not release air by removing the strut valve core or filler plug. Depress the valve core pin until the strut chamber pressure has diminished.

940

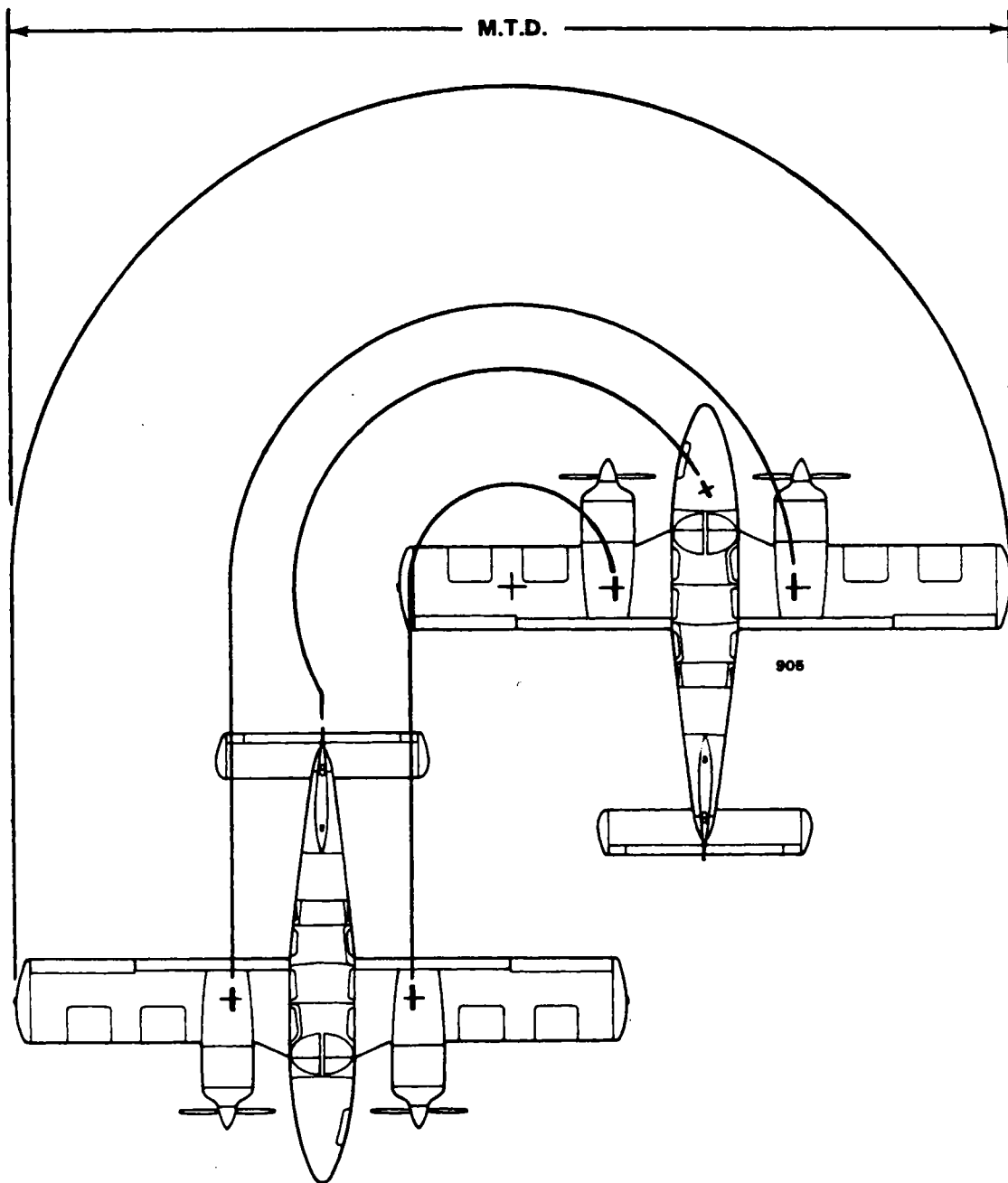

MINIMUM TURNING DISTANCE (M.T.D.) 60.4 Ft.

Figure 2-7. Turning Distance

CAUTION

Dirt and foreign particles form around the filler plugs of the landing gear struts, therefore, before attempting to remove these plugs, the area around the filler plugs should be cleaned with compressed air and/or with a quick drying solvent.

2-35. FILLING NOSE GEAR OLEO STRUT. To fill the nose gear oleo strut with hydraulic fluid (MIL-H-5606), whether it be only the addition of a small amount or if the unit has been completely emptied and will require a large amount, it should be filled as follows:

- a. Raise the airplane on jacks. (Refer to Paragraph 2-12.)
- b. Place a pan under the gear to catch spillage.
- c. Relieve air pressure from the strut housing chamber by removing the cap from the air valve and depressing the valve core.
- d. There are two methods by which the strut chamber may be filled and these are as follows:

Method I: Addition of small amounts of fluid.

1. Remove the valve core from the filler plug at the top of the nose gear strut housing. Allow the filler plug to remain installed.
2. With the piston tube extended, fill the strut with approved type fluid.
3. Attach one end of a clean plastic hose to the valve stem of the filler plug and submerge the other end of the hose in a container of clean hydraulic fluid; make sure the end of the hose is below the surface of the fluid.

NOTE

An air tight connection is necessary between the plastic tube and the valve stem. Without such a connection, a small amount of air will be sucked into the oleo strut during each sequence, resulting in an inordinate amount of air bubbles and prolonged filling operations.

4. Fully compress and extend the piston tube, thus expelling any air trapped within the strut chamber. By watching the fluid pass through the plastic hose, it can be determined when the strut is full and no air is present in the chamber.
5. When air bubbles cease to flow through the hose, compress the piston fully and remove the hose from the valve stem. Remove the filler plug to determine that fluid level is visible up to the bottom of the filler plug hole.
6. Reinstall the core in the filler plug and the plug in the strut housing and torque from 350 to 400 inch-pounds.

Method II - Filling completely empty struts.

1. Proceed with steps A through C.
2. Remove the filler plug at the top inboard side of the gear housing.
3. Disconnect the torque links by removing any one of the three torque link bolts.

PPS40045D

CAUTION

With the torque link disconnected, the strut tube is free to slide out of the trunnion.

4. Extend the piston to a visible strut extension of 10 inches minimum - 12 inches maximum.
5. Add one-half pint minimum of hydraulic fluid through the air valve hole and allow it to drain and fill the chamber below the top bearing hole.

1970

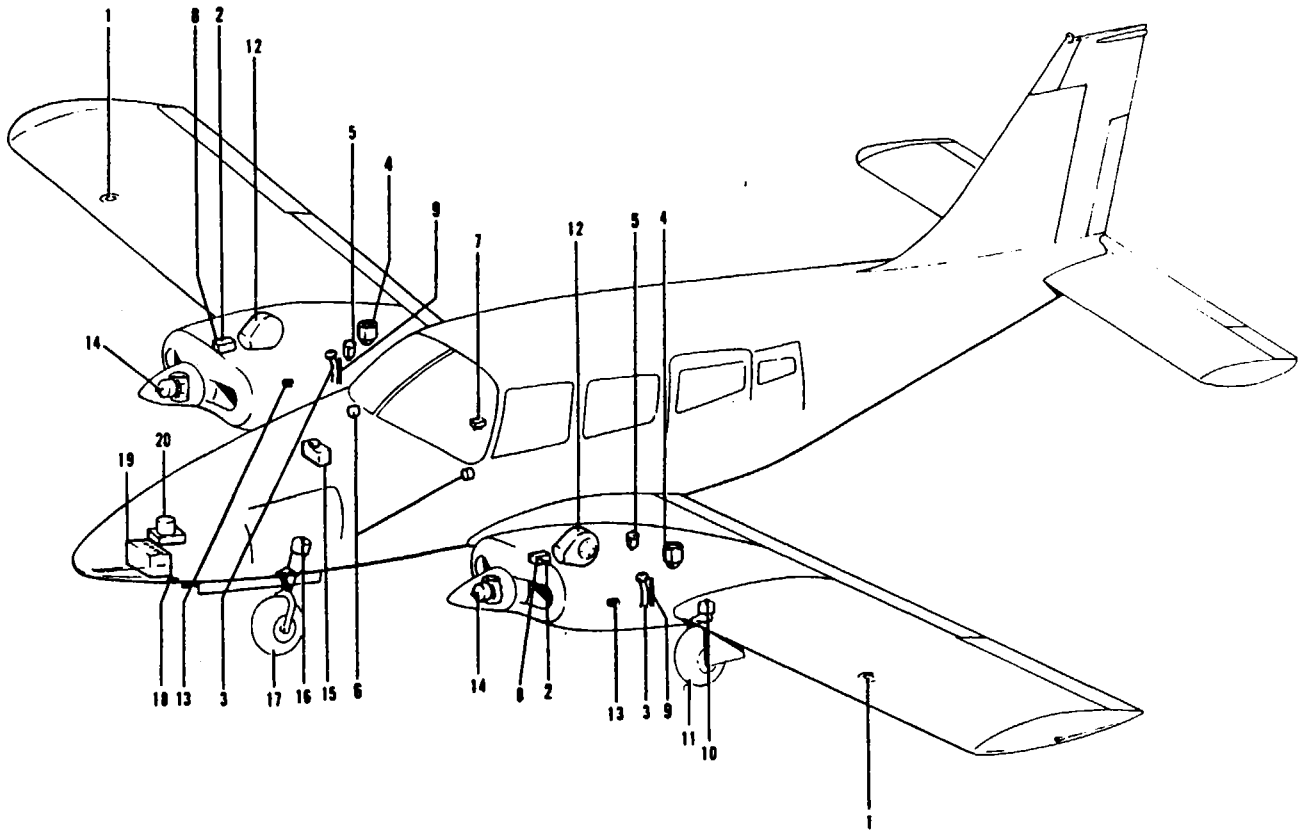

- | | |
|-------------------------------|-------------------------------|
| 1. FUEL FILLERS | 11. MAIN GEAR TIRES |
| 2. FUEL INJECTORS | 12. INDUCTION AIR FILTERS |
| 3. ENGINE OIL FILL | 13. ENGINE OIL SUCTION SCREEN |
| 4. ENGINE OIL FILTERS | 14. PROPELLER AIR CHARGE |
| 5. FUEL FILTERS | 15. BRAKE RESERVOIR |
| 6. INSTRUMENT AIR FILTERS | 16. NOSE GEAR STRUT |
| 7. FUEL SYSTEM DRAINS | 17. NOSE GEAR TIRE |
| 8. FUEL METERING CONTROL UNIT | 18. EXTERNAL POWER RECEPTACLE |
| 9. OIL DIPSTICK | 19. BATTERY |
| 10. MAIN GEAR STRUT | 20. HYDRAULIC RESERVOIR |

Figure 2-8. Service Points

6. Reconnect the torque links.
7. Add hydraulic fluid through the air valve hole until the fluid level reaches the bottom (or lower side) of the air valve hole with the piston fully compressed and no air trapped in the assembly below the valve hole.

NOTE

Gear assemblies with the air valve hole on the side of the cylinder may be serviced in the horizontal position with the air valve hole vertical.

8. Install the air valve and torque it from 350 to 400 inch pounds.

2-36. FILLING MAIN GEAR OLEO STRUTS. To fill the main gear oleo struts with hydraulic fluid (MIL-H-5606) one of the following methods should be used, depending on the type of service performed on the strut assembly:

- a. **Method I:** Addition of small amount of fluid.
 1. Raise the airplane on jacks. (Refer to Paragraph 2-12.)
 2. Place a pan under the gear to catch any spillage.
 3. Relieve the air pressure from the strut housing chamber by removing the cap from the air valve and depressing the valve core.
 4. Remove the valve core from the filler plug and allow the filler plug to remain installed.
 5. With the piston tube extended, fill the strut with the approved type hydraulic fluid.
 6. Attach one end of a clear plastic hose to the valve stem of the filler plug and submerge the other end of the hose in a container of clean hydraulic fluid; make sure the end of the hose is below the surface of the fluid.

NOTE

An air tight connection is necessary between the plastic tube and the valve stem. Without such a connection, a small amount of air will be sucked into the oleo strut during each sequence, resulting in an inordinate amount of air bubbles and prolonged filling operations.

7. Fully compress and extend the piston tube, thus expelling any air trapped within the strut chamber. By watching the fluid pass through the plastic hose, it can be determined when the strut is full and no air is present in the chamber.
8. When air bubbles cease to flow through the hose, fully compress the piston and remove the hose from the valve stem. Remove the filler plug to determine that fluid is visible up to the bottom of the filler plug hole.
9. Reinstall the air valve core in the filler plug and the plug in the strut housing and torque to 45 foot-pounds.
10. With the airplane still on jacks, compress and extend the gear piston tube several times to ascertain that the strut will operate freely. The weight of the gear, wheel, and fork should allow the piston tube to extend.
11. Clean off any overflow of fluid and inflate the strut with air to 250 psi.
12. Remove the aircraft from jacks and check strut exposure per Paragraph 2-34.

Method II - Filling completely empty struts.

PP450045D

1. Proceed with steps 1 through 3 of Method I.
2. Remove the filler plug at the top inboard side of the main gear housing.
3. Disconnect the torque links by removing any one of the three torque link bolts.

CAUTION

With the torque link disconnected, the strut tube is free to slide out of the trunnion.

4. Extend the piston to a visible strut extension of 10 inches minimum - 12 inches maximum.
5. Add one-half pint minimum of hydraulic fluid through the air valve hole and allow it to drain and fill the chamber below the top bearing hole.
6. Reconnect the torque links.
7. Add hydraulic fluid through the air valve hole until the fluid level reaches the bottom (or lower side) of the air valve hole with the piston fully compressed and no air trapped in the assembly below the valve hole.

NOTE

Gear assemblies with the air valve hole on the side of the cylinder may be serviced in the horizontal position with the air valve hole vertical.

8. Reinstall the air valve core in the filler plug and the plug in the strut housing and torque the plug from 350 to 400 inch-pounds.

2-37. **INFLATING OLEO STRUTS.** After making certain that an oleo strut has sufficient fluid, attach a strut pump to the air valve. With the airplane at empty weight (full fuel and oil only) fill the main strut to 250 psi and the nose gear to 150 psi. Rock the airplane several times to ascertain that the gear settles back to the correct strut position. If a strut pump is not available, the airplane may be raised with line pressure from a high pressure air system. Before capping the valve, check for valve core leakage.

2-38. **SERVICING STEERING BUNGEEES.** At the specified frequency according to the Lubrication Chart, the steering bungees must be serviced as follows:

- a. Remove the access panels located in the forward baggage compartment.
- b. Clamp the rudder pedals in the neutral position as shown in Figure 5-11.
- c. Remove the nut, washers, and bolt that secures the steering bungee and the steering arm.
- d. Remove the clamp that secures the boot, on the frame at station 49.50, to the bungee.
- e. Within the fuselage, disconnect the bungee from the rudder pedal arm by removing the nut, washer and bolt.
- f. Remove the steering bungee from the aircraft.
- g. Cut the safety wire from the bungee retainer.
- h. Carefully remove the retainer and release the spring.
- i. Apply Aero Lubriplate to the spring and mounting hardware as specified in the Lubrication Chart.
- j. Compress the spring into the bungee tube and install the retainer securing with MIL-W-6713 Type 316 safety wire.
- k. Ascertain that the measurement taken between the facing sides of the washers at the rod end is 13.71 inches.
- l. With the nose gear in the neutral position, install the steering bungee into position. The web must be in the vertical position. (Refer to Figure 7-2.)
- m. Install the bolt, washers, and nut that secures the bungee to the steering arm.
- n. Install the bolt, washer, and nut that secures the bungee to the rudder pedal arm.
- o. Install the boot clamp.
- p. Repeat this procedure for the other steering bungee.
- q. Align the nose gear per Alignment of Nose Landing Gear, Section VII.
- r. Remove the rudder pedal clamps and check the operation of the steering bungees.
- s. Install the access panels in the forward baggage compartment with the attachment hardware.

2-39. **TIRES.**

2-40. **SERVICING TIRES.** The tires should be maintained at the pressure specified in Table II-I. When checking tire pressure, examine the tires for wear, cuts, bruises and slippage. The tire, tube, and wheel should be balanced when installed. Align the index mark on the tire with the index mark on the tube.

2-41. **HYDRAULIC SYSTEM.**

2-42. **SERVICING HYDRAULIC SYSTEM.** The hydraulic pump and landing gear actuating cylinders should be checked for leaks, tightness of line fittings and general condition. The cylinder rods are to be free of all dirt and grit. To clean the rods, use an oil soaked rag and carefully wipe them. All the hydraulic lines should also be checked for leaks, kinks, corrosion and attachment fittings for tightness and security. Repair and check procedures for the hydraulic pump, cylinders, and various components may be found in Section VI of this manual.

2-43. **SERVICING HYDRAULIC PUMP/RESERVOIR.** The fluid level of the reservoir of the combination pump and reservoir should be checked every 50 hours by viewing the fluid through the filler plug hole in the hydraulic pump. Access to the pump is through the panel at the right forward side of the nose baggage compartment.

To check fluid level, remove the filter plug located on the forward side of the pump and ascertain that fluid is visible up to the bottom of the filler plug hole. Should fluid be below the hole, add fluid, MIL-H-5606, through the filler hole until full. Reinstall the filler plug and tighten.

NOTE

A small vent hole is located under the vent screw head. Retain 1/64 inch clearance between the screw head and small vent hole.

2-44. **BATTERY.**

2-45. **SERVICING BATTERY.** Servicing of the battery which is located under the floor panel of the forward baggage compartment, involves adding distilled water to maintain electrolyte even with the horizontal baffles, checking cable connections, and checking for any spilled electrolyte that would lead to corrosion. A check for proper fluid level and presence of corrosion should be conducted at intervals of 50 hours or 30 days, whichever comes first. When corrosion is found, at each 100 hour inspection or every 90 days, the battery should be removed from the box and the battery and box should be cleaned. Removal, cleaning, and charging instructions may be found in Section XI of this manual.

2-46. **CLEANING.**

2-47. **CLEANING ENGINE COMPARTMENTS.** Before cleaning the engine compartments, place a strip of tape on the magneto vents to prevent any solvent from entering these units.

- a. Place a pan under the engines to catch waste.
- b. With the engine cowlings removed, spray or brush the engines with solvent or a mixture of solvent and degreaser as desired. It may be necessary to brush areas that were sprayed, where heavy grease and dirt deposits have collected in order to clean them.

CAUTION

Do not spray solvent into the alternator, starter, air intake, alternate air inlets and pressure pump drive area.

- c. Allow the solvent to remain on the engine from five to 10 minutes; then rinse the engine clean with additional solvent and allow to dry.

CAUTION

Do not operate engines until excess solvent has evaporated or otherwise been removed.

- d. Remove the protective covers from magnetos.
- e. Lubricate controls, bearing surfaces, etc., per Lubrication Chart.

2-48. **CLEANING LANDING GEAR.** Before cleaning the landing gear, place a plastic cover or similar material over the wheel and brake assembly.

- a. Place a pan under the gear to catch waste.
- b. Spray or brush the gear area with solvent or a mixture of solvent and degreaser as desired. It may be necessary to brush areas that were sprayed where heavy grease and dirt deposits have collected in order to clean them. Do not brush micro switches.
- c. Allow the solvent to remain on the gear from 5 to 10 minutes; then rinse the gear with additional solvent and allow to dry.
- d. Remove the cover from the wheel and remove the catch pan.
- e. Lubricate the gear per Lubrication Chart.

2-49. **CLEANING EXTERIOR SURFACES.** The airplane should be washed with a mild soap and water. Harsh abrasive or alkaline soaps or detergents used on painted or plastic surfaces could make scratches or cause corrosion of metal surfaces. Cover areas where cleaning solution could cause damage. To wash the airplane, the following procedure may be used:

- a. Flush away loose dirt with water.
- b. Apply cleaning solution with a rag, sponge or soft bristle brush.
- c. To remove stubborn oil and grease, use a cloth dampened with naphtha.
- d. Where exhaust stains exist, allow solution to remain on the surface longer.
- e. Any good automotive wax may be used to preserve the painted surfaces. Soft cleaning cloths or a chamois should be used to prevent scratches when cleaning or polishing. A heavier coating of wax on the leading surfaces will reduce the abrasion problems in these areas.

2-50. **CLEANING WINDSHIELD AND WINDOWS.**

- a. Remove dirt, mud, etc., from exterior surfaces with clean water.
- b. Wash with mild soap and warm water or an aircraft plastic cleaner. Use a soft cloth or sponge using a straight rubbing motion. Do not harshly rub surfaces.
- c. Remove oil and grease with a cloth moistened with kerosene.

NOTE

Do not use gasoline, alcohol, benzene, carbon tetrachloride, thinner, acetone, or window cleaning sprays.

- d. After cleaning plastic surfaces, apply a thin coat of hard polishing wax. Rub lightly with a soft cloth. Do not use a circular motion.
- e. A severe scratch or mar in plastic can be removed by using jeweler's rouge to rub out the scratch. Smooth both sides and apply wax.
- f. Visibility through the windshield may be improved when flying through rain by using a water repellent on the windows such as Repcon. Refer to the List of Consumable Materials for purchasing information.

2-51. **CLEANING HEADLINER, SIDE PANELS AND SEATS.**

- a. Clean headliner, side panels, and seats with a stiff bristle brush and vacuum where necessary.
- b. Soiled upholstery, except leather, may be cleaned by using an approved air type cleaner or foam upholstery cleaner. Carefully follow the manufacturer's instructions. Avoid soaking or harsh rubbing.

CAUTION

Solvent cleaners require adequate ventilation.

- c. Leather material should be cleaned with saddle soap or mild soap and water.

Revised: 8/10/80

1B21

HANDLING AND SERVICING

2-52. **CLEANING CARPETS.** Use a small whisk broom or vacuum to remove dirt. For soiled spots, use a non-inflammable dry-cleaning fluid. Floor carpets may be removed and cleaned like any household carpet.

2-53. **LUBRICATION.**

2-54. **OIL SYSTEM (ENGINE).**

2-55. **SERVICING OIL SYSTEM.** The engine oil level should be checked before each flight and changed after each 100 hours of engine operation. During oil change the oil screen(s) should be removed and cleaned, and the oil filter cartridge replaced. Replace oil filter at 50 hour intervals. The engine manufacturer does not recommend oils by brand names. Use a quality brand Aviation Grade oil of the proper season viscosity. For information on the use of detergent oil, refer to Paragraph 2-60.

CAUTION

Do not introduce any trade additive to the basic lubricant unless recommended by the manufacturer.

2-56. **FILLING OIL SUMP.** The oil sump should normally be filled with oil to the mark on the engine dipstick. The quantity of oil required for the engines may be found in Table II-I. The specified grade of oil may be found in Table II-III, the Lubrication Chart, or on the cowl panel access door of each engine. To service the engine with oil, open the access door of the cowl and remove the oil filler cap.

2-57. **DRAINING OIL SUMP.** To drain the oil sump, provide a suitable container with a minimum capacity of that required to fill the sump. Remove the access panel in the lower cowl and remove oil drain plug located on the underside of the engine. It is recommended the engine be warmed to operating temperature to insure complete draining of the old oil.

2-58. **OIL SCREEN (SUCTION).** The oil suction screen is located on the bottom aft end of the engine sump, installed horizontally. To remove, cut the safety wire and remove the hex head plug. The screen should be cleaned at each oil change to remove any accumulation of sludge and to examine for metal filings or chips. If metal particles are found in the screen, the engine should be examined for internal damage. After cleaning and inspection, place the screen inside the recess in the hex head plug to eliminate possible damage to the screen. Insert the screen into the housing and when certain that the screen is properly seated, tighten and safety the plug with MS-20995-C41 safety wire.

2-59. **OIL FILTER (FULL FLOW).**

a. The oil filter should be replaced after each 50 hours of engine operation; this is accomplished by removing the lockwire from the bolt head at the end of the filter, loosening and removing the filter assembly from the adapter.

b. Before discarding the filter, remove the outer cover, and using a sharp knife, cut through the folds of the element at both ends. Then carefully unfold the pleated element and examine the material trapped in the filter for evidence of internal engine damage such as chips or particles from bearings. In new or newly overhauled engines, some small particle or metallic shavings might be found; these are generally of no consequence and should not be confused with particles produced by impacting, abrasion or pressure. Evidence of internal engine damage found in the oil filter justifies further examination to determine the cause.

NOTE

Ascertain that oil filter completes with specifications of Continental Aircraft Engine Service Bulletin M75-7.

- c. Before installing the new filter, lubricate the gasket on the filter with engine oil, then install. Tighten slightly more than hand tight or 3/4 to 1 full turn after gasket makes contact. Do not over torque.
- d. Run the engine and check for oil leaks; then install lockwire between nut on filter and oil filter adapter assembly.

2-60. RECOMMENDATIONS FOR CHANGING OIL. The engine manufacturer recommends that the oil supply be drained and the entire sump filled with fresh oil after each 100 hours of engine operation. Always start and warm the engine to operating temperature before performing an oil change. While draining the oil, the screens should be removed from the crankcase cover and cleaned thoroughly. If sludge deposits are heavy, subsequent oil changes should be made at shorter intervals. Detergent oil that meets the latest revision of Continental Motors Corporation Specification MHS-24, is the only recommended lubricating oil. Use SAE-30 15W-50 or 20W-50 below 40° F and SAE-50 15W-50, 20W-50 or 25W-60 above 40° F. When the average ambient air temperature is approximately at the dividing line, use the lighter oil.

2-61. LUBRICATION INSTRUCTIONS. Proper lubrication procedures are of immeasurable value both as a means of prolonging the service life of the airplane and as a means of reducing the frequency of extensive and expensive repairs. The periodic application of recommended lubricants to their relevant bearing surfaces, as detailed in the following paragraphs, together with the observance of cleanliness will insure the maximum efficiency and utmost service of all moving parts. Lubrication instruction regarding the locations, time intervals, and type of lubricants used may be found in the Lubrication Chart. To insure the best possible results from the application of lubricants, the following precautions should be observed:

- a. Use recommended lubricants. Where general purpose lubricating oil is specified, but unavailable, clean engine oil may be used as a satisfactory substitute.
- b. Check the components to be lubricated for evidence of excessive wear and replace them as necessary.
- c. Remove all excess lubricants from components in order to prevent the collection of dirt and sand in abrasive quantities capable of causing excessive wear or damage to bearing surfaces.

NOTE

If the airplane is inactive for long periods of time, it should be lubricated in accordance with Lubrication Chart every 90 days.

2-62. APPLICATION OF OIL. Whenever specific instructions for lubrication of mechanisms requiring lubrication are not available, observe the following precautions:

- a. Apply oil sparingly, never more than enough to coat the bearing surfaces.
- b. Since the control cables are sufficiently coated by the manufacturer, additional protection for the prevention of corrosion is unnecessary.
- c. Squeeze the magneto cam follower felts at regular inspection periods. If oil appears on fingers, do not add oil. If the felt is dry, moisten with light oil.

CAUTION

Be careful not to add too much oil, because the excess will be thrown off during operation and will cause pitting and burning of the magneto points.

2-63. APPLICATION OF GREASE. Care must be taken when lubricating bearings and bearing surfaces with a grease gun, to insure that gun is filled with new clean grease of the grade specified for the particular application before applying lubricant to the grease fittings.

a. Where a reservoir is not provided around a bearing, apply the lubricant sparingly and wipe off any excess.

b. Remove wheel bearings from the wheel hub and clean thoroughly with a suitable solvent. When repacking with grease, be sure the lubricant enters the space between the rollers in the retainer ring. Do not pack the grease into the wheel hub.

c. Use extra care when greasing the constant speed propeller hub to avoid blowing the clamp gaskets. Remove one grease fitting and apply grease to the other fitting until fresh grease appears at the hole of the removed fitting.

2-64. LUBRICATION CHARTS. The lubrication charts consists of individual illustrations for the various aircraft systems, and each component to be lubricated is indicated by a number, the type of lubricant and the frequency of application. Special instructions are listed at the beginning of the lubrication charts and with the applicable component illustration.

TYPE OF LUBRICANTS

SPECIFICATION	LUBRICANT
MIL-L-7870	LUBRICATING OIL, GENERAL PURPOSE, LOW TEMPERATURE
LATEST REVISION OF MHS-248 = TCM SPECIFICATION	LUBRICATING OIL, AIRCRAFT RECIPROCATING ENGINE (PISTON) GRADE AS SPECIFIED SAE 50 15W-50, 20W-50 OR 25W-60 ABOVE 40°F AMBIENT AIR (S.L.) SAE 30 15W-50 OR 20W-50 BELOW 40° AMBIENT AIR (S.L.)
MIL-H-5606	HYDRAULIC FLUID, PETROLEUM BASE
MIL-G-23827	GREASE, AIRCRAFT AND INSTRUMENT, GEAR AND ACTUATOR SCREW TEXACO MARFAK ALL PURPOSE GREASE, MOBIL MOBIL GREASE 77 (OR MOBIL EP2 GREASE)
MIL-G-7711	GREASE - LUBRICATION GENERAL PURPOSE AIRCRAFT FLUOROCARBON RELEASE AGENT DRY LUBRICANT # MS-122 (PURCH)
AERO	LUBRIPLATE (PURCH) FISKE BROS. REFINING CO.

SPECIAL INSTRUCTIONS

1. BEARINGS AND BUSHINGS - CLEAN EXTERIOR WITH A DRY TYPE SOLVENT BEFORE LUBRICATING.
2. LUBRICATION POINTS - WIPE ALL LUBRICATION POINTS CLEAN OF OLD GREASE, OIL, DIRT, ETC., BEFORE LUBRICATING.

NOTES

1. FUEL SYSTEM - SERVICE REGULARLY - FUEL PUMP STRAINER - INJECTOR SCREEN - FILTER BOWL - QUICK DRAIN UNIT.
2. BATTERY - FLUID LEVEL AND CONDITION CHECK EVERY 25 HOURS.

CAUTIONS

1. DO NOT USE HYDRAULIC FLUID WITH A CASTOR OIL OR ESTER BASE.
2. DO NOT OVERLUBRICATE COCKPIT CONTROLS.
3. DO NOT APPLY LUBRICANT TO RUBBER PARTS.
4. DO NOT LUBRICATE CABLES - THIS CAUSES SLIPPAGE.

37110.D

• PIPER SENECA II SERVICE MANUAL

COMPONENT	LUBRICANT	FREQUENCY
1. MAIN GEAR PIVOT POINTS	MIL-G-23827	100 HRS
2. MAIN GEAR DOOR HINGE	MIL-L-7870	100 HRS
3. MAIN GEAR TORQUE LINKS	MIL-L-7870	100 HRS
4. EXPOSED OLEO STRUT MAIN	FLUOROCARBON RELEASE AGENT DRY LUBRICANT #MS-122	100 HRS
5. MAIN GEAR WHEEL BEARINGS	TEXACO MARFAX ALL PURPOSE GREASE OR MOBIL MOBIL GREASE 77 (OR MOBIL EP2 GREASE)	100 HRS
6. MAIN GEAR DOOR CONTROL ROD ENDS	MIL-L-7870	100 HRS
7. MAIN GEAR SIDE BRACE LINK ASSEMBLY	MIL-G-23827	100 HRS
8. UPPER SIDE BRACE SWIVEL FITTING	MIL-G-23827	100 HRS
9. MAIN GEAR DOWNLOCK ASSEMBLY RETRACTION FITTING AND CYLINDER ATTACHMENT POINTS	MIL-L-7870	100 HRS
10. OLEO STRUT FILLER POINT (MAIN GEAR)	MIL-H-5606	AS REQUIRED
11. HYDRAULIC PUMP RESERVOIR	MIL-H-5606	100 HRS
12. BRAKE RESERVOIR	MIL-H-5606	100 HRS

1880

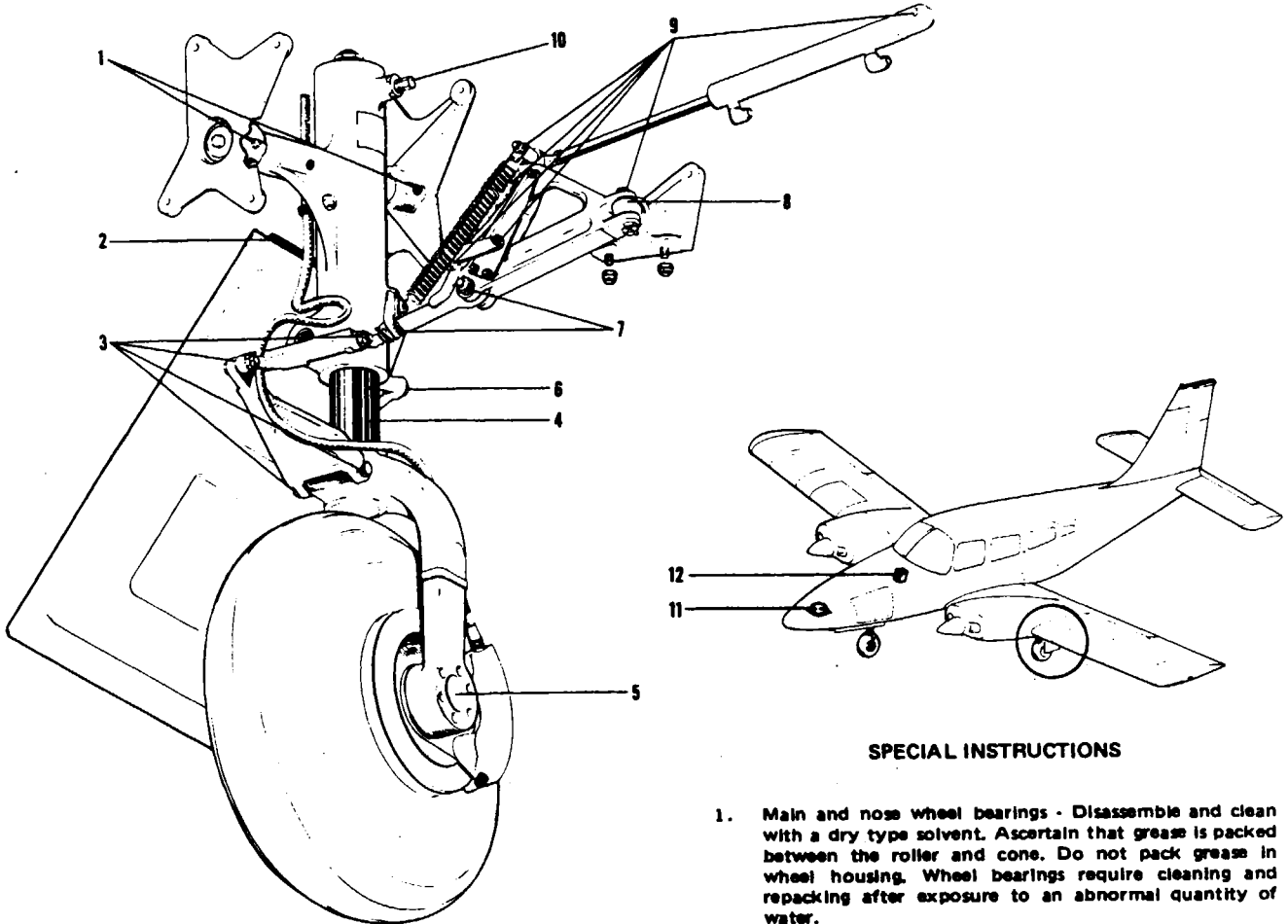

SPECIAL INSTRUCTIONS

1. Main and nose wheel bearings - Disassemble and clean with a dry type solvent. Ascertain that grease is packed between the roller and cone. Do not pack grease in wheel housing. Wheel bearings require cleaning and repacking after exposure to an abnormal quantity of water.
2. Oleo struts, hydraulic pump reservoir and brake reservoir - Fill per instructions on unit or container or refer to service manual.

Figure 2-9. Lubrication Chart (Landing Gear, Main)

COMPONENT	LUBRICANT	FREQUENCY
1. NOSE GEAR STRUT HOUSING	MIL-G-23827	100 HRS
2. NOSE GEAR PIVOT POINT AND HYDRAULIC CYLINDER ROD END	MIL-L-7870	100 HRS
3. NOSE GEAR DOOR RETRACTION MECHANISM	MIL-L-7870	100 HRS
4. NOSE GEAR DOOR HINGES	MIL-L-7870	100 HRS
5. EXPOSED OLEO STRUT	FLUOROCARBON RELEASE AGENT DRY LUBRICANT # MS-122	100 HRS
6. NOSE WHEEL BEARINGS	TEXACO MARFAX ALL PURPOSE GREASE OR MOBIL GREASE 77 (OR MOBIL EP2 GREASE)	100 HRS
7. NOSE GEAR TORQUE LINK ASSEMBLY	MIL-L-7870	100 HRS
8. NOSE GEAR TORQUE LINK ASSEMBLY AND STRUT HOUSING	MIL-G-23827	100 HRS
9. NOSE GEAR PIVOT POINT, DRAG LINK ASSEMBLY, DOWNLOCK AND CYLINDER ASSEMBLY, STEERING ROLLER AND CENTERING SPRING PIVOT POINTS	MIL-L-7870	100 HRS
10. LINK BUSHING	MIL-L-7870	100 HRS
11. BUNGEEES	AERO LUBRIPLATE MAG-1 OR AEROSHELL #7	100 HRS
12. STEERING BELLCRANK PIVOT POINTS AND ROD ENDS	MIL-L-7870	100 HRS
13. NOSE GEAR ROLLER TRACK	MIL-G-7711	100 HRS
14. NOSE GEAR OLEO STRUT FILLER POINT	MIL-H-5606	AS REQUIRED

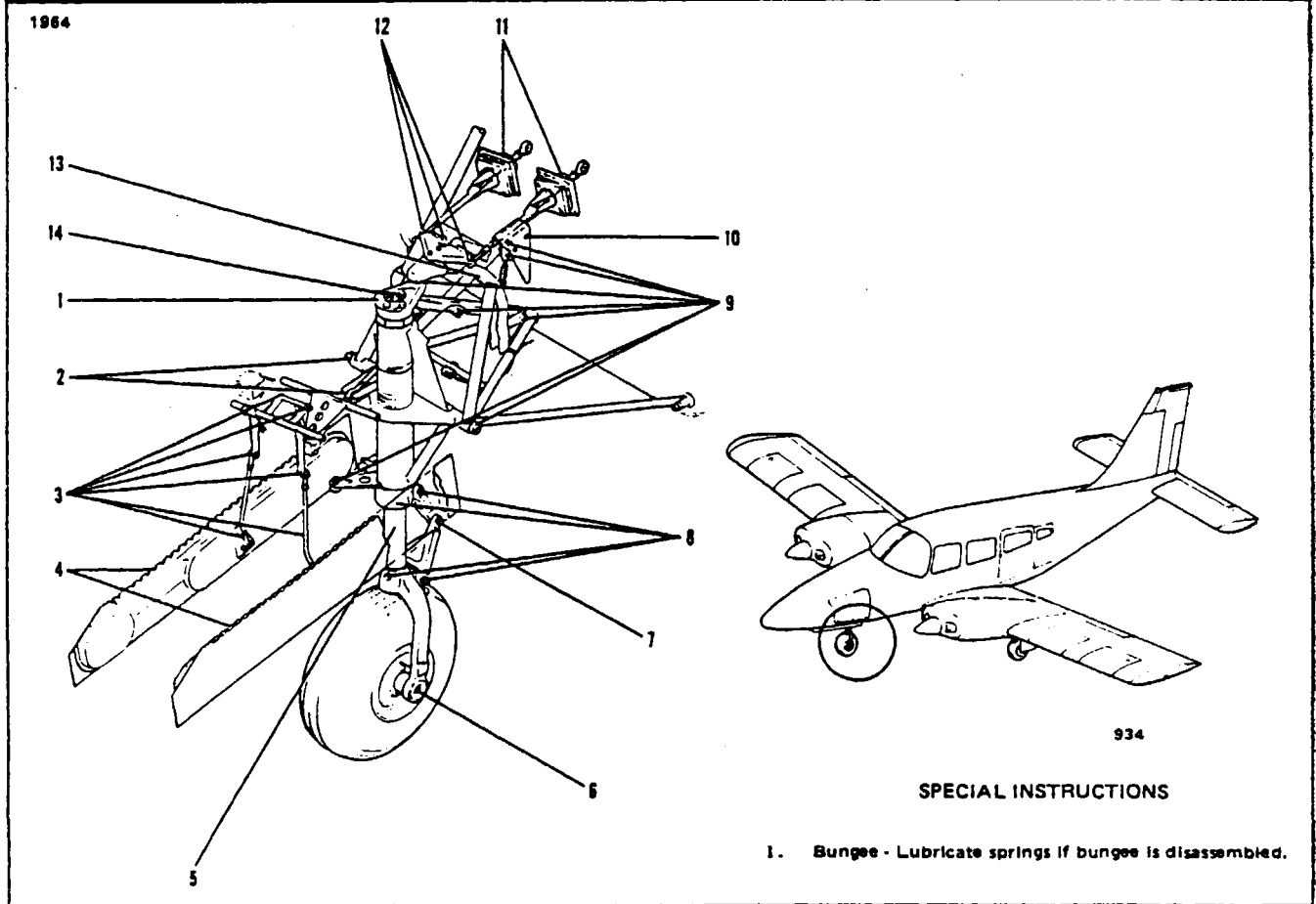

37110-D

Figure 2-10. Lubrication Chart (Landing Gear, Nose)

PIPER SENECA II SERVICE MANUAL

— CAUTION —

Do not lubricate control wheel shaft or bushing. Clean only using alcohol or other suitable solvent.

COMPONENT	LUBRICANT	FREQUENCY
1 FLAP HINGE BEARINGS	MIL-L-7870	100 HRS
2 RUDDER TRIM SCREW	AERO LUBRIPLATE, AERO #907, MAG #1 OR AEROSHELL #7	100 HRS
3 CONTROL CABLE PULLEYS	MIL-L-7870	100 HRS
4 TRIM CONTROL WHEELS - STABILATOR AND RUDDER	MIL-L-7870	100 HRS
5 CONTROL COLUMN FLEX JOINT AND SPROCKET	MIL-L-7870	100 HRS
6 O-RING CONTROL SHAFT BUSHING	FLUOROCARBON RELEASE AGENT DRY LUBRICANT #MS-122	100 HRS
7 TEE BAR PIVOT POINTS, AILERON AND STABILATOR CONTROL PULLEYS	MIL-L-7870	100 HRS
8 STABILATOR CONTROL ROD, ROD END BEARINGS LINKS AND IDLER PULLEY	MIL-L-7870	100 HRS
9 FLAP CONTROL ROD END BEARINGS	MIL-L-7870	100 HRS
10 FLAP RETURN AND TENSION CHAIN	MIL-L-7870	500 HRS
11 FLAP HANDLE PIVOT POINT LOCK MECHANISM AND CABLE PULLEY	MIL-L-7870	100 HRS
12 FLAP TORQUE TUBE BEARING BLOCK	MIL-L-7870	100 HRS
13 AILERON AND STABILATOR CONTROL CHAIN	MIL-L-7870	500 HRS

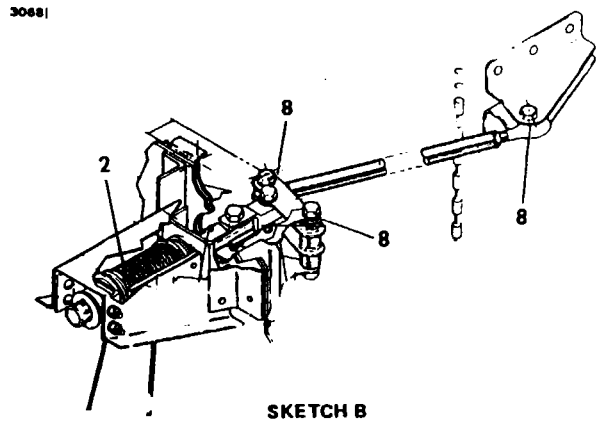
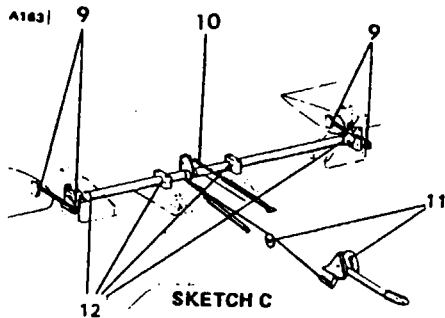
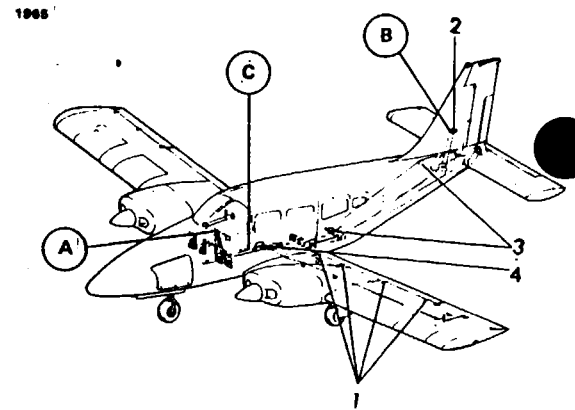
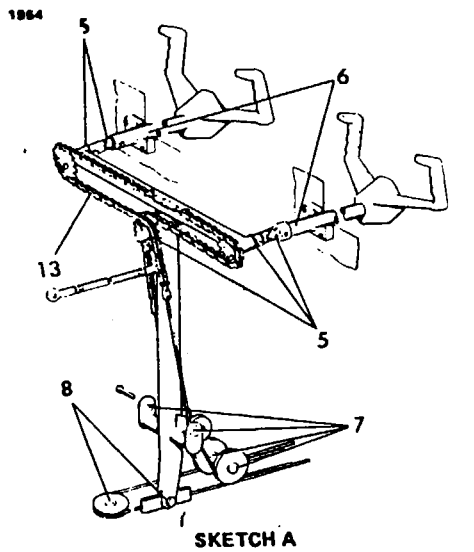
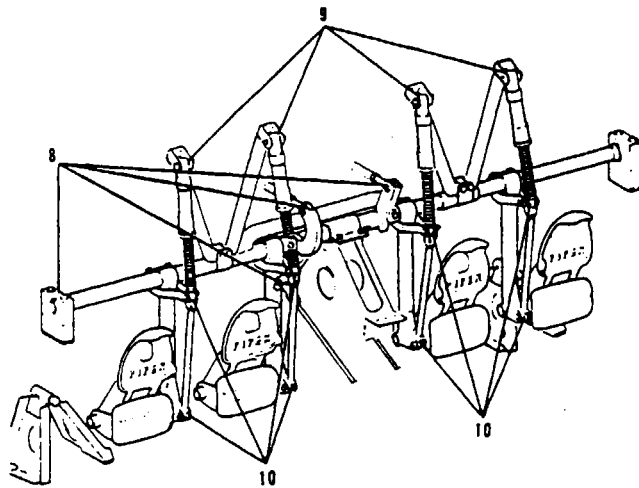

Figure 2-11. Lubrication Chart (Control System)

COMPONENT	LUBRICANT	FREQUENCY
1. AILERON HINGE PINS	MIL-L-7870	100 HRS
2. AILERON HINGE PINS	MIL-L-7870	100 HRS
3. CONTROL CABLE PULLEYS	MIL-L-7870	100 HRS
4. STABILATOR TRIM SCREW	AERO LUBRIPLATE, MAG #1 OR AEROSHELL #7	100 HRS
5. RUDDER HINGE AND TAB HINGE BEARINGS	MIL-L-7870	100 HRS
6. ARM BUSHING	MIL-L-7870	100 HRS
7. STABILATOR TRIM TAB HINGE PINS	MIL-L-7870	100 HRS
8. RUDDER TUBE CONNECTIONS, TUBE CABLE ENDS AND STEERING ROD ENDS	MIL-L-7870	100 HRS
9. TOE BRAKE ATTACHMENTS	MIL-L-7870	100 HRS
10. BRAKE ROD ENDS	MIL-L-7870	100 HRS
11. RUDDER SECTOR AND STABILATOR TRIM PIVOT POINTS	MIL-L-7870	100 HRS
12. AILERON CONTROL ROD END BEARINGS	MIL-L-7870	100 HRS
13. AILERON BELLCRANK CABLE ENDS	MIL-L-7870	100 HRS

938



SKETCH A

A268

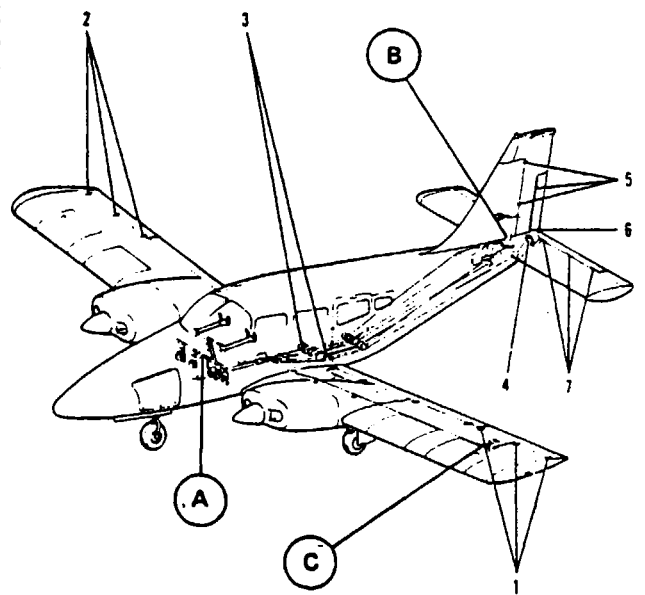

2016

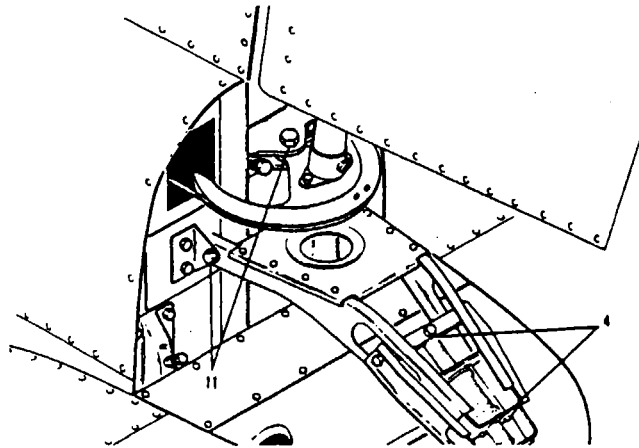

SKETCH B

C188

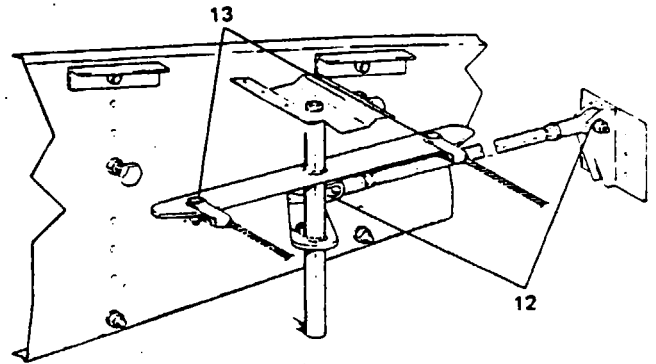

SKETCH C

Figure 2-12. Lubrication Chart (Control System) (cont.)

PIPER SENECA II SERVICE MANUAL *

COMPONENT	LUBRICANT	FREQUENCY
1. ENGINE OIL SUMPS	THE LATEST REVISIONS OF CONTINENTAL SPECIFICATION MHS-24A AND SERVICE BULLETIN M75-2	100 HRS
2. OIL FILTERS	SEE SPECIAL INSTRUCTIONS NO. 2 AND 3.	50 HRS
3. INDUCTION AIR FILTERS	CLEAN AS OFTEN AS NECESSARY, EVERYDAY UNDER SEVERE CONDITIONS	
4. ALTERNATE AIR DOORS	MIL-L-7870	100 HRS
5. GOVERNOR CONTROLS	MIL-L-7870	100 HRS
6. CONTROL QUADRANT CONTROLS	MIL-L-7870	100 HRS
7. PROPELLER ASSEMBLY	MIL-G-23827	100 HRS
8. COWL FLAP ACTUATING MECHANISM	AERO LUBRIPLATE, MAG-11 OR AEROSHELL #7	500 HRS

A271

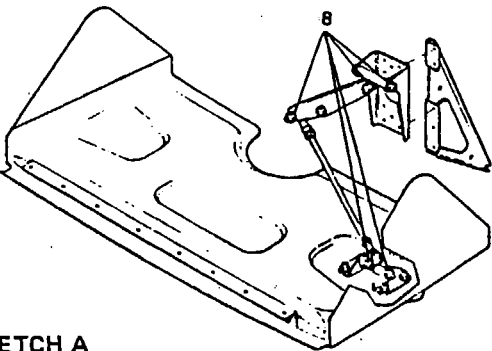

SKETCH A

A286

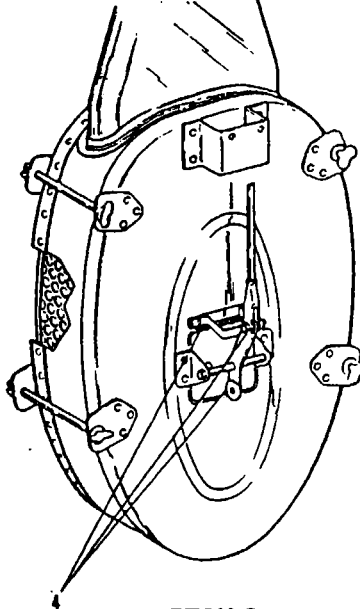

SKETCH C

A272

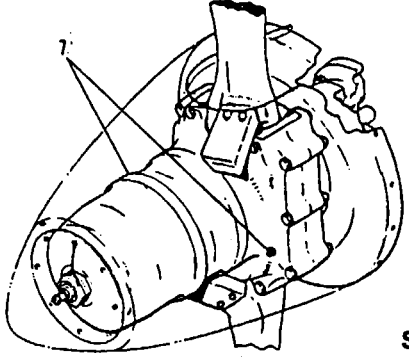

SKETCH B

SPECIAL INSTRUCTIONS

- Air filter - To clean filter, tap gently to remove dirt particles. Do not blow out with compressed air or use oil; replace filter if punctured or damaged.
- See the latest revision of TCM Service Bulletin M-81-11 Rev. 1 for recommended oil and filter change period. The engine lubricating oil system is serviced with MIL-C-6529, Type II for the initial fill and for the first 25 hours engine time per the latest revisions of TCM Operator's Manual and MHS-184. Service engine thereafter with oil per the latest revisions of MHS-24B and TCM Service Bulletin M-81-11 Rev. 1.
- Ascertain that oil filter complies with specifications of the latest revision of TCM Service Bulletin M75-7.
- Propeller - Remove one of two grease fittings for each blade. Apply grease through fitting until fresh grease appears at hole of removed fitting.
- Lubricate outer surface of inner spacer on cowl flap linkage

37110-D

Figure 2-13. Lubrication Chart (Power Plant & Propeller)

COMPONENT	LUBRICANT	FREQUENCY
1. FORWARD BAGGAGE DOOR	MIL-L-7870	100 HRS
2. LATCH MECHANISM	MIL-L-7870	500 HRS
3. PILOT AND COPILOT SEAT ADJUSTMENT	MIL-G-7711	100 HRS
4. MAIN DOOR HINGES AND LATCH MECHANISM	MIL-L-7870	500 HRS
5. BAGGAGE AND REAR DOOR HINGES AND LATCH MECHANISM	MIL-L-7870	500 HRS

2017

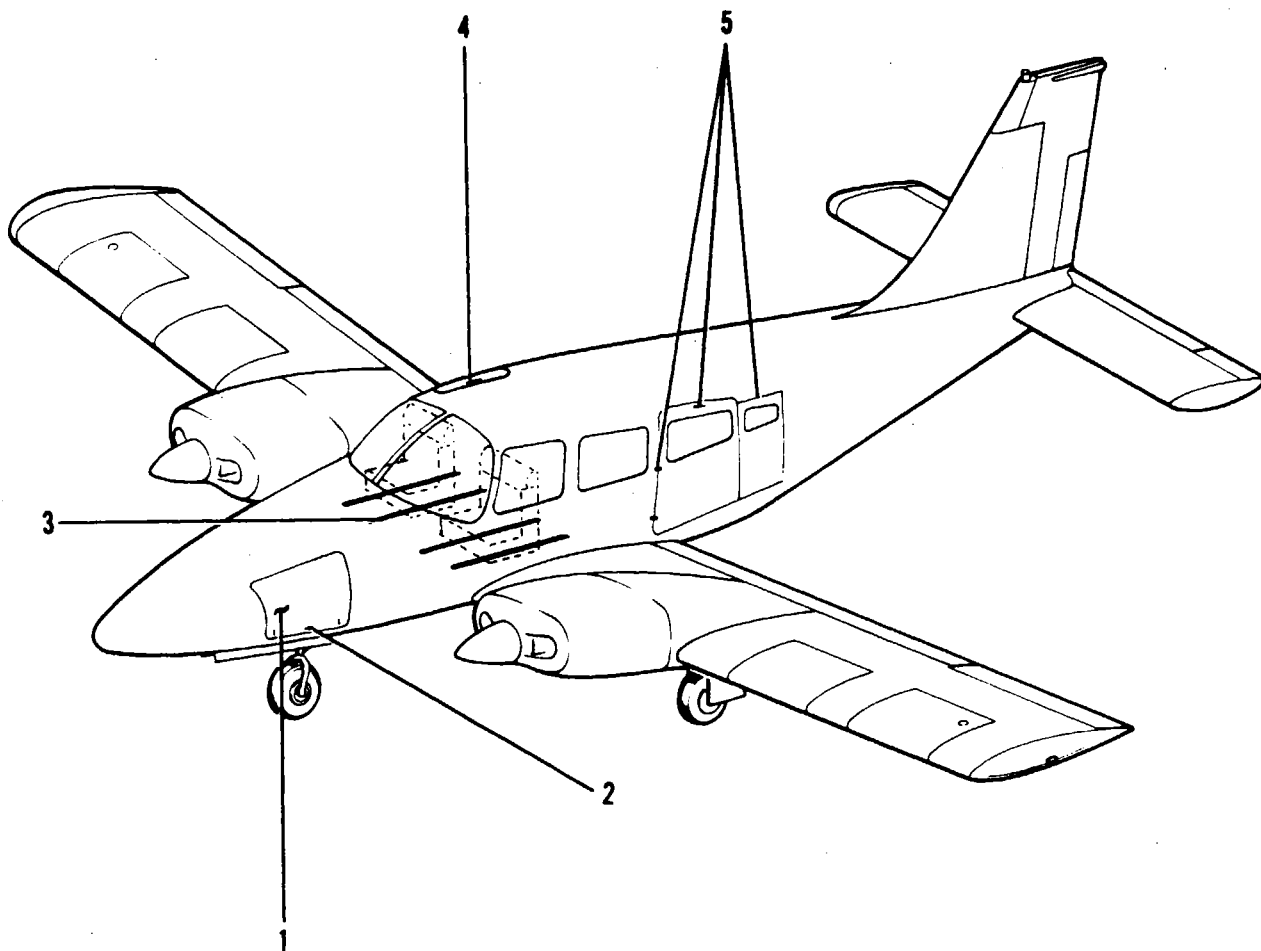

SPECIAL INSTRUCTIONS

1. Pilot and passenger seats - Lubricate track rollers and stop pins as required.

37110 D

Figure 2-14. Lubrication Chart (Cabin Door, Baggage Door & Seats)

Revised: 11/12/82

HANDLING AND SERVICING

1C7

TABLE II-III. CONVERSION TABLES

1. These charts contain the various conversion data that may be useful when figuring capacities, length, temperatures, and various weights and measures from the English system values to the metric system values or back again.
2. The English system is in use by England and the United States. All other countries use the metric system.
3. Procedure for Converting Inches to Millimeters.
 - A. Example: Convert 1.5 inches to millimeters.
 - (1) Read down inches column to 1. inches.
 - (2) Read across top inch column to 0.5.
 - (3) Read down and across to find millimeters (1.5 inches is 38.10 millimeters).
4. Procedure for converting Fahrenheit (°F) and Celsius (°C) (Centigrade) temperature.
 - A. Read number in middle column, if in degrees Celsius (°C), read Fahrenheit equivalent in right-hand column. If in degrees Fahrenheit (°F), read Celsius equivalent in left-hand column.
 - (1) $70^{\circ}\text{F} = 21.1^{\circ}\text{C}$.
 - (2) $30^{\circ}\text{C} = 86.0^{\circ}\text{F}$.

PIPER SENECA II SERVICE MANUAL

TABLE II-III. CONVERSION TABLES (cont.)

INCHES TO MILLIMETER										
INCHES	0.0000	0.0001	0.0002	0.0003	0.0004	0.0005	0.0006	0.0007	0.0008	0.0009
	MILLIMETER									
0.000		0.0025	0.0050	0.0076	0.0101	0.0127	0.0152	0.0177	0.0203	0.0228
0.001	0.0254	0.0279	0.0304	0.0330	0.0355	0.0381	0.0406	0.0431	0.0457	0.0482
0.002	0.0508	0.0533	0.0558	0.0584	0.0609	0.0635	0.0660	0.0685	0.0711	0.0736
0.003	0.0762	0.0812	0.0838	0.0863	0.0889	0.0914	0.0939	0.0965	0.0965	0.0990
0.004	0.1016	0.1041	0.1066	0.1092	0.1117	0.1143	0.1168	0.1193	0.1219	0.1244
0.005	0.1270	0.1295	0.1320	0.1346	0.1371	0.1397	0.1422	0.1447	0.1447	0.1498
0.006	0.1524	0.1549	0.1574	0.1600	0.1625	0.1651	0.1676	0.1701	0.1727	0.1752
0.007	0.1778	0.1803	0.1828	0.1854	0.1879	0.1905	0.1930	0.1955	0.1981	0.2006
0.008	0.2032	0.2057	0.2082	0.2108	0.2133	0.2159	0.2184	0.2209	0.2235	0.2260
0.009	0.2286	0.2311	0.2336	0.2362	0.2387	0.2413	0.2438	0.2463	0.2489	0.2514
INCHES	0.000	0.001	0.002	0.003	0.004	0.005	0.006	0.007	0.008	0.009
	MILLIMETER									
0.00		0.025	0.050	0.076	0.101	0.127	0.152	0.177	0.203	0.228
0.01	0.254	0.279	0.304	0.330	0.355	0.381	0.406	0.431	0.457	0.482
0.02	0.508	0.533	0.558	0.584	0.609	0.635	0.660	0.685	0.711	0.736
0.03	0.762	0.787	0.812	0.838	0.863	0.889	0.914	0.939	0.965	0.990
0.04	1.016	1.041	1.066	1.092	1.117	1.143	1.168	1.193	1.219	1.244
0.05	1.270	1.295	1.320	1.346	1.371	1.397	1.422	1.447	1.473	1.498
0.06	1.524	1.549	1.574	1.600	1.625	1.651	1.676	1.701	1.727	1.752
0.07	1.778	1.803	1.828	1.854	1.879	1.905	1.930	1.955	1.981	2.006
0.08	2.032	2.057	2.082	2.108	2.133	2.159	2.184	2.209	2.235	2.260
0.09	2.286	2.311	2.336	2.362	2.387	2.413	2.438	2.463	2.489	2.514
INCHES	0.00	0.01	0.02	0.03	0.04	0.05	0.06	0.07	0.08	0.09
	MILLIMETER									
0.0		0.254	0.508	0.762	0.016	1.270	1.524	1.778	2.032	2.286
0.1	2.540	2.794	3.048	3.302	3.556	3.810	4.064	4.318	4.572	4.826
0.2	5.080	5.334	5.558	5.842	6.096	6.350	6.604	6.858	7.112	7.366
0.3	7.620	7.874	8.128	8.382	8.636	8.890	9.144	9.398	9.652	9.906
0.4	10.160	10.414	10.668	10.922	11.176	11.430	11.684	11.938	12.192	12.446
0.5	12.700	12.954	13.208	13.462	13.716	13.970	14.224	14.478	14.732	14.986
0.6	15.240	15.494	15.748	16.002	16.256	16.510	16.764	17.018	17.272	17.526
0.7	17.780	18.034	18.288	18.542	18.796	19.050	19.304	19.558	19.812	20.066
0.8	20.320	20.574	20.828	21.082	21.336	21.590	21.844	22.098	22.352	22.606
0.9	22.860	23.114	23.368	23.622	23.876	24.130	24.384	24.638	24.892	25.146

Added: 8/10/80

1C9

HANDLING AND SERVICING

PIPER SENECA II SERVICE MANUAL

TABLE II-III. CONVERSION TABLES (cont.)

CHART A. INCHES TO MILLIMETER (cont.)										
INCHES	0.00	0.1	0.2	0.3	0.4	0.5	0.6	0.7	0.8	0.9
	MILLIMETER									
0.		2.54	5.08	7.62	10.16	12.70	15.24	17.78	20.32	22.86
1.	25.40	27.94	30.48	33.02	35.56	38.10	40.64	43.18	45.72	48.26
2.	50.80	53.34	55.88	58.42	60.96	63.50	66.04	68.58	71.12	73.66
3.	76.20	78.74	81.28	83.82	86.36	88.90	91.44	93.98	96.52	99.06
4.	101.60	104.14	106.68	109.22	111.76	114.30	116.84	119.38	121.92	124.46
5.	127.00	129.54	132.08	134.62	137.16	139.70	142.24	144.78	147.32	149.86
6.	152.40	154.94	157.48	160.02	162.56	165.10	167.64	170.18	172.72	175.26
7.	177.80	180.34	182.88	185.42	187.96	190.50	193.04	195.58	198.12	200.66
8.	203.20	205.74	208.28	210.82	213.36	215.90	218.44	220.98	223.52	226.06
9.	228.60	231.14	233.68	236.22	238.76	241.30	243.84	246.38	248.92	251.46

THIS SPACE INTENTIONALLY LEFT BLANK

TABLE II-III. CONVERSION TABLES (cont.)

CHART B. FRACTION/DECIMAL CONVERSIONS

4THS	8THS	16THS	32DS	64THS	TO 3 PLACES	TO 2 PLACES	M.M. EQUIV.	4THS	8THS	16THS	32DS	64THS	TO 3 PLACES	TO 2 PLACES	M.M. EQUIV.
			$\frac{1}{32}$	$\frac{1}{64}$.016	.02	.397				$\frac{17}{32}$	$\frac{33}{64}$.516	.52	13.097
			$\frac{2}{32}$	$\frac{2}{64}$.031	.03	.794				$\frac{18}{32}$	$\frac{35}{64}$.531	.53	13.494
		$\frac{1}{16}$		$\frac{3}{64}$.047	.05	1.191			$\frac{9}{16}$		$\frac{37}{64}$.547	.55	13.891
		$\frac{1}{16}$		$\frac{4}{64}$.062	.06	1.587			$\frac{9}{16}$		$\frac{38}{64}$.562	.56	14.288
			$\frac{3}{32}$	$\frac{5}{64}$.078	.08	1.984				$\frac{19}{32}$	$\frac{39}{64}$.578	.58	14.684
			$\frac{3}{32}$	$\frac{6}{64}$.094	.09	2.381				$\frac{20}{32}$	$\frac{41}{64}$.594	.59	15.081
	$\frac{1}{8}$			$\frac{7}{64}$.109	.11	2.778		$\frac{5}{16}$		$\frac{42}{64}$	$\frac{43}{64}$.609	.61	15.478
	$\frac{1}{8}$			$\frac{8}{64}$.125	.12	3.175		$\frac{5}{16}$		$\frac{43}{64}$	$\frac{44}{64}$.625	.62	15.875
			$\frac{5}{32}$	$\frac{9}{64}$.141	.14	3.572				$\frac{21}{32}$	$\frac{45}{64}$.641	.64	16.272
			$\frac{5}{32}$	$\frac{10}{64}$.156	.16	3.969				$\frac{22}{32}$	$\frac{46}{64}$.656	.66	16.669
		$\frac{3}{16}$		$\frac{11}{64}$.172	.17	4.366			$\frac{11}{16}$		$\frac{47}{64}$.672	.67	17.065
		$\frac{3}{16}$		$\frac{12}{64}$.188	.19	4.762			$\frac{11}{16}$		$\frac{48}{64}$.688	.69	17.462
			$\frac{7}{32}$	$\frac{13}{64}$.203	.20	5.159				$\frac{23}{32}$	$\frac{49}{64}$.703	.70	17.859
			$\frac{7}{32}$	$\frac{14}{64}$.219	.22	5.556				$\frac{24}{32}$	$\frac{50}{64}$.719	.72	18.256
	$\frac{1}{4}$			$\frac{15}{64}$.234	.23	5.953		$\frac{3}{4}$		$\frac{47}{64}$	$\frac{51}{64}$.734	.73	18.653
	$\frac{1}{4}$			$\frac{16}{64}$.250	.25	6.350		$\frac{3}{4}$		$\frac{48}{64}$	$\frac{52}{64}$.750	.75	19.050
			$\frac{9}{32}$	$\frac{17}{64}$.266	.27	6.747				$\frac{25}{32}$	$\frac{53}{64}$.766	.77	19.447
			$\frac{9}{32}$	$\frac{18}{64}$.281	.28	7.144				$\frac{26}{32}$	$\frac{54}{64}$.781	.78	19.844
		$\frac{5}{16}$		$\frac{19}{64}$.297	.30	7.540			$\frac{13}{16}$		$\frac{55}{64}$.797	.80	20.241
		$\frac{5}{16}$		$\frac{20}{64}$.312	.31	7.937			$\frac{13}{16}$		$\frac{56}{64}$.812	.81	20.637
			$\frac{11}{32}$	$\frac{21}{64}$.328	.33	8.334				$\frac{27}{32}$	$\frac{57}{64}$.828	.83	21.034
			$\frac{11}{32}$	$\frac{22}{64}$.344	.34	8.731				$\frac{28}{32}$	$\frac{58}{64}$.844	.84	21.431
	$\frac{3}{8}$			$\frac{23}{64}$.359	.36	9.128		$\frac{7}{8}$		$\frac{55}{64}$	$\frac{59}{64}$.859	.86	21.828
	$\frac{3}{8}$			$\frac{24}{64}$.375	.38	9.525		$\frac{7}{8}$		$\frac{56}{64}$	$\frac{60}{64}$.875	.88	22.225
			$\frac{13}{32}$	$\frac{25}{64}$.391	.39	9.922				$\frac{29}{32}$	$\frac{61}{64}$.891	.89	22.622
			$\frac{13}{32}$	$\frac{26}{64}$.406	.41	10.319				$\frac{30}{32}$	$\frac{62}{64}$.906	.91	23.019
		$\frac{7}{16}$		$\frac{27}{64}$.422	.42	10.716			$\frac{15}{16}$		$\frac{63}{64}$.922	.92	23.416
		$\frac{7}{16}$		$\frac{28}{64}$.438	.44	11.112			$\frac{15}{16}$		$\frac{64}{64}$.938	.94	23.812
			$\frac{15}{32}$	$\frac{29}{64}$.453	.45	11.509				$\frac{31}{32}$	$\frac{65}{64}$.953	.95	24.209
			$\frac{15}{32}$	$\frac{30}{64}$.469	.47	11.906				$\frac{32}{32}$	$\frac{66}{64}$.969	.97	24.606
				$\frac{31}{64}$.484	.48	12.303					$\frac{63}{64}$.984	.98	25.003
				$\frac{32}{64}$.500	.50	12.700					$\frac{64}{64}$	1.000	1.00	25.400

PIPER SENECA II SERVICE MANUAL

TABLE II-III. CONVERSION TABLES (cont.)

CHART C. CENTIGRADE—FAHRENHEIT CONVERSION TABLE

Example: To convert 20°C. to Fahrenheit, find 20 in the center column headed (F—C); then read 68.0°F. in the column (F) to the right. To convert 20°F. to Centigrade; find 20 in the center column and read -6.67°C. in the (C) column to the left.

C	F—C	F	C	F—C	F
-56.7	-70	-94.0	104.44	220	428.0
-51.1	-60	-76.0	110.00	230	446.0
-45.6	-50	-58.0	115.56	240	464.0
-40.0	-40	-40.0	121.11	250	482.0
-34.0	-30	-22.0	126.67	260	500.0
-38.9	-20	-4.0	132.22	270	518.0
-23.3	-10	14.0	137.78	280	536.0
-17.8	0	32.0	143.33	290	554.0
-12.22	10	50.0	148.89	300	572.0
-6.67	20	68.0	154.44	310	590.0
-1.11	30	86.0	160.00	320	608.0
4.44	40	104.0	165.56	330	626.0
10.00	50	122.0	171.11	340	644.0
15.56	60	140.0	176.67	350	662.0
21.11	70	158.0	182.22	360	680.0
26.67	80	176.0	187.78	370	698.0
32.22	90	194.0	193.33	380	716.0
37.78	100	212.0	198.89	390	734.0
43.33	110	230.0	204.44	400	752.0
48.89	120	248.0	210.00	410	770.0
54.44	130	266.0	215.56	420	788.0
60.00	140	284.0	221.11	430	806.0
65.56	150	302.0	226.67	440	824.0
71.11	160	320.0	232.22	450	842.0
76.67	170	338.0	237.78	460	860.0
82.22	180	356.0	243.33	470	878.0
87.78	190	374.0	248.89	480	896.0
93.33	200	392.0	254.44	490	914.0
98.89	210	410.0	260.00	500	932.0

TABLE II-III. CONVERSION TABLES (cont.)

CHART D. ENGLISH VS METRIC

MULTIPLY	BY	TO OBTAIN
CENTIMETERS	0.3937 0.03281	IN. FT.
CU. CENTIMETERS	0.001 0.06102 0.0002642	LITERS CU. IN. U.S. GAL.
CU. FT.	28.320 1.728 7.481 28.32	CU. CM CU. IN. U.S. GAL. LITERS
CU. IN.	16.39 0.01639 0.004329 0.01732	CU. CM LITERS U.S. GAL. QUARTS
CU. METERS	1000000 35.314 61.023 264.17 999.97	CU. CM CU. FT. CU. IN. GAL. LITERS
FEET	0.3048 12.000 304.8 0.3333	METERS MILS MM. YARDS
FT.-LB.	0.1383 0.001285 0.000000376	M-KG BTU KW-HR
FLUID OZ.	8 29.6	DRAM CU. CM
GAL., IMPERIAL	277.4 1.201 4.546	CU. IN. U.S. GAL. LITERS
GAL., U.S. DRY	268.8 0.1556 1.164 4.405	CU. IN. CU. FT. U.S. GAL., LIQ. LITERS
GAL., U.S. LIQ.	231.0 0.1337 3.785 0.8327 128	CU. IN. CU. FT. LITERS IMPERIAL GAL. FLUID OZ.
IN.	2.540 .08333	CM. FT.
JOULES	0.000948 0.7376	FT. FT.-LB.

MULTIPLY	BY	TO OBTAIN
KILOGRAMS	2.205 35.27 1000	LB. OZ. GRAMS
LITERS	1000 61.03 0.03532 0.2642 0.22 1.057	CU. CM. CU. IN. CU. FT. U.S. GAL. IMPERIAL GAL. QUARTS
METERS	39.37 3.281 1000	IN. FT. MM.
METER-KILOGRAM	7.233 9.807	FT.-LB. JOULES
OUNCES, AVDP	0.0625 28.35 437.5	LB., AVDP GRAMS GRAINS
OUNCES, FLUID	29.57 1.805	CU. CM. CU. IN.
LB., AVDP	453.6 7000 16.0	GRAMS GRAINS OUNCES
SQUARE INCH	6.4516	SQ. CM.
POUND PER SQUARE INCH (PSI)	0.0703	KG.-CM SQUARED
STATUTE MILE	1.609 0.8684	KILOMETER NAUTICAL MILE
NAUTICAL MILE	1.151	STATUTE MILE
QUART	.9463	LITER
MILLIMETER	1000	MICRON
MICRON	0.001 0.000039	MILLIMETER INCH
INCH POUNDS	11.521	METER GRAMS
INCH OUNCES	0.72	METER GRAMS
POUNDS	0.453	KILOGRAMS

Added: 8/10/80

PIPER SENECA II SERVICE MANUAL

TABLE II-III. CONVERSION TABLES (cont.)

CHART E. DECIMAL/MILLIMETER EQUIVALENTS OF DRILL SIZES FROM 1/2" TO NO. 80

Decimal/Millimeter Equivalents of Drill Sizes From 1/2" to No. 80											
Size	Decimal Equiv.	Millimeter Equiv.	Size	Decimal Equiv.	Millimeter Equiv.	Size	Decimal Equiv.	Millimeter Equiv.	Size	Decimal Equiv.	Millimeter Equiv.
1/2	0.500	12.7000	G	0.261	6.6294	5/32	0.1562	3.9687	51	0.067	1.7018
31/64	0.4843	12.3031	F	0.257	6.5278	23	0.154	3.9116	52	0.0635	1.6129
15/32	0.4687	11.9062	E-1/4	0.250	6.3500	24	0.152	3.8608	17/16	0.0625	1.5875
29/64	0.4531	11.5094	D	0.246	6.2484	25	0.1495	3.7973	53	0.0595	1.5113
7/16	0.4375	11.1125	C	0.242	6.1468	26	0.147	3.7338	54	0.055	1.397
27/64	0.4218	10.7156	B	0.238	6.0452	27	0.144	3.6576	55	0.052	1.3208
Z	0.413	10.4902	15/64	0.2343	5.9531	9/64	0.1406	3.5719	3/64	0.0468	1.1906
13/32	0.4062	10.3187	A	0.234	5.9436	28	0.1405	3.5687	56	0.0465	1.1811
Y	0.404	10.2616	1	0.228	5.7912	29	0.136	3.4544	57	0.043	1.0922
X	0.397	10.0838	2	0.221	5.6134	30	0.01285	3.2639	58	0.042	1.0668
25/64	0.3906	9.9212	7/32	0.2187	5.5562	1/8	0.125	3.1750	59	0.041	1.0414
W	0.386	9.8044	3	0.213	5.4102	31	0.120	3.048	60	0.040	1.016
V	0.377	9.5758	4	0.209	5.3086	32	0.116	2.9464	61	0.039	0.9906
3/8	0.375	9.5250	5	0.2055	5.2197	33	0.113	2.8702	62	0.038	0.9652
U	0.368	9.3472	6	0.204	5.1816	34	0.111	2.8194	63	0.037	0.9398
23/64	0.3593	9.1262	13/64	0.2031	5.1594	35	0.110	2.794	64	0.036	0.9144
T	0.358	9.1281	7	0.201	5.1054	7/64	0.1093	2.7781	65	0.035	0.899
S	0.346	8.7884	8	0.199	5.0546	36	0.1065	2.7051	66	0.033	0.8382
11/32	0.3437	8.7300	9	0.196	4.9784	37	0.104	2.6416	1/32	0.0312	0.7937
R	0.339	8.6106	10	0.1935	4.9149	38	0.1015	2.5781	67	0.032	0.8128
Q	0.332	8.4328	11	0.191	4.8514	39	0.0995	2.5273	68	0.031	0.7874
21/64	0.3281	8.3337	12	0.189	4.8006	40	0.098	2.4892	69	0.029	0.7366
P	0.323	8.2042	3/16	0.1875	4.7625	41	0.096	2.4384	70	0.028	0.7112
O	0.316	8.0264	13	0.185	4.699	3/32	0.0937	2.3812	71	0.026	0.6604
5/16	0.3125	7.9375	14	0.182	4.6228	42	0.0935	2.3749	72	0.025	0.635
N	0.302	7.6708	15	0.180	4.572	43	0.089	2.2606	73	0.024	0.6096
19/64	0.2968	7.5387	16	0.177	4.4958	44	0.086	2.1844	74	0.0229	0.58166
M	0.295	7.4930	17	0.173	4.3942	45	0.082	2.0828	75	0.021	0.5334
L	0.290	7.3660	11/64	0.1718	4.3656	46	0.081	2.0574	76	0.020	0.508
9/32	0.2812	7.1425	18	0.1695	4.3053	47	0.0785	1.9939	77	0.018	0.4572
K	0.281	7.1374	19	0.166	4.2164	5/64	0.0781	1.9844	1/64	0.0156	0.3969
J	0.277	7.0358	20	0.161	4.0894	48	0.076	1.9304	78	0.016	0.4064
I	0.272	6.9088	21	0.159	4.0386	49	0.073	1.8542	79	0.0145	0.3683
H	0.266	6.7564	22	0.157	3.9878	50	0.070	1.778	80	0.0135	0.3429
17/64	0.2656	6.7462									

DRILL SIZES AVAILABLE
 Drill may be obtained in regular sizes to a 4 inch diameter, and increase in 64ths of an inch.
 The regular metric drills vary from 2 to 76mm and increase in 0.5mm variations.

TABLE II-IV. LIST OF CONSUMABLE MATERIALS

MATERIAL	SPECIFICATION	BRAND NAME	MANUFACTURER
Grease, High Temperature	MIL-G-3545 QPL-3545-15	High Temp Grease, Marfax all Purpose	Texaco, Inc., 135 East 42nd, New York, New York 10017
		Shellaire Grease HT, Alvania EP Grease 2, Aeroshell Grease 5	Shell Oil Co., 50 West 50th Street New York, New York 10020
		Grease 77, Mobilux EP2	Mobil Oil Corporation Shoreham Building Washington, D.C. 20005
		Royco 45A	Royal Lubricants, Co., River Road, Hanover, New Jersey 07936
		L-1231	Sinclair Refining Co., 600 Fifth Avenue, New York, New York 10020
Hydraulic Fluid	MIL-H-5606 QPL-5606-12	Aircraft Hydraulic Oil AA	Texaco, Inc., 135 East 42nd, New York, New York 10017
		RPM Aviation Oil No. 2 Code PED 2585, PED 3337	Standard Oil of California, 225 Bush St., San Francisco, California, 94120
		3126 Hydraulic Oil, Univis 40	Exxon Company, U.S.A., Box 2180, Houston, Texas 77001
		Aeroshell Fluid 4, Aeroshell Fluid 4 SL-7694	Shell Oil Co., 50 West 50th Street, New York, New York 10020
		Aero HF	Mobil Oil Corporation Shoreham Building, Washington, D.C. 20005
		Royco 756, 756A, 756B	Royal Lubricants, Co., River Road, Hanover, New Jersey 07936

Reissued: 10/11/79

PIPER SENECA II SERVICE MANUAL

TABLE II-IV. LIST OF CONSUMABLE MATERIALS (cont.)

MATERIAL	SPECIFICATION	BRAND NAME	MANUFACTURER
Lubricating Grease	MIL-G-7711 QPL-7711-15	Regal AFB2, Regal Starfak Premium 2	Texaco, Inc., 135 East 42nd., New York, New York 10017
		PED 3040	Standard Oil of California, 225 Bush St., San Francisco, California 94120
		Aeroshell Grease 6	Shell Oil Co., 50 West 50th. Street, New York, New York 10020
		Royco 11	Royal Lubricants, Co., River Road, Hanover, New Jersey 07936
Lubricating Oil General Purpose, Low Temperature	MIL-L-7870 QPL-7870-9	1692 Low Temp Oil	Texaco, Inc., 135 East 42nd., New York, New York 10017
		Aviation Instrument Oil	Standard Oil of California, 225 Bush St., San Francisco California 94120
		Royco 363	Royal Lubricants, Co., River Road, Hanover, New Jersey 07936
		Sinclair Aircraft Orbit lube	Sinclair Refining Co., 600 Fifth Avenue, New York, New York 10020
		Caltex Low Temp Oil	Caltex Oil Products Co., New York, New York

PIPER SENECA II SERVICE MANUAL

TABLE II-IV. LIST OF CONSUMABLE MATERIALS (cont.)

MATERIAL	SPECIFICATION	BRAND NAME	MANUFACTURER
Grease Aircraft and Instrument, Gear and Actuator Screw	MIL-G-23827 QPL-23827-10 (See Note 2)	Low Temp Grease EP	Texaco, Inc., 135 East 42nd., New York, New York 10017
		5114 EP Grease, AV 55	Standard Oil of California, 225 Bush St., San Francisco, California 94120
		Aeroshell Grease 7, Braycote 627S	Shell Oil Co., 50 West 50th. Street, New York, New York 10020
		Mobil Grease 27	Mobil Oil Corporation Shoreham Building, Washington, D.C. 20005
		Royco 27A	Royal Lubricants Co., River Road, Hanover, New Jersey 07936
		Castrolase AL	Castrol Oils Inc., Newark, New Jersey
		Supermil Grease No. A72832	American Oil Company 165 N. Canal, Chicago, Illinois 60606
		BP Aero Grease 31B	BP Trading Limited Moore Lane, Britannic House, London E.C. 2 England
Grease, Aircraft, General Purpose Wide Temperature Range	ML-81322 QPL-81322-3 (See Note 2)	Aeroshell Grease 22	Shell Oil Co., 50 West 50th Street, New York, New York 10020
		Mobil Grease 28	Mobil Oil Corporation Shoreham Building, Washington, D.C. 20005
		Royco 22	Royal Lubricants Co., River Road, Hanover, New Jersey 07936

Reissued: 10/11/79

1C17

HANDLING AND SERVICING

PIPER SENECA II SERVICE MANUAL

TABLE II-IV. LIST OF CONSUMABLE MATERIAL (cont.)

MATERIAL	SPECIFICATION	BRAND NAME	MANUFACTURER
Grease, Aircraft and Instruments, High and Low Temperature	MIL-G-3278 QPL-3278-24	Unitemp EP	Texaco, Inc., 135 East 42nd., New York, New York 10017
		RPM Avn. Grease 5, Supermil Grease No. 8723	Standard Oil of California, 225 Bush St., San Francisco, California 94120
		Aeroshell Grease 7A	Shell Oil Co., 50 West 50th Street, New York, New York 10020
		Mobil Grease 22	Mobil Oil Corporation Shoreham Building, Washington, D.C. 20005
		Royco 78	Royal Lubricants Co., River Road, Hanover, New Jersey 07936
		L-1212	Sinclair Refining Co., 600 Fifth Avenue New York, New York 10020
		1916 Uni-Temp Grease	California Texas Oil Corp., 380 Madison Ave., New York, New York 10017
Lubricating Grease Molybdenum Disulfide	MIL-G-21164 QPL-21164-15	Aeroshell Grease 17	Shell Oil Co., 50 West 50th Street, New York, New York 10020
		Royco 64C	Royal Lubricants Co., River Road, Hanover, New Jersey 07936
		Castrolase MSA (C)	Castrol Oil Inc., 254-266 Doremus Avenue, Newark, New Jersey 07105

PIPER SENECA II SERVICE MANUAL

TABLE II-IV. LIST OF CONSUMABLE MATERIALS (cont.)

MATERIAL	SPECIFICATION	BRAND NAME	MANUFACTURER
Grease, Ball and Roller Bearing	MIL-G-18709 QPL-18709-55	Regal ASB-2 Formula TG-10293	Texaco, Inc., 135 East 42nd., New York, New York 10017
		Andok B	Exxon Company, U.S.A., Box 2180, Houston, Texas 77001
		Code 1-20481, Darina Grease 1 XSG-6213 Code 71-501, Darina Grease 2 XSG-6152 Code 71-502, Alvania Grease 2 XSG-6151 Code 71-012, Cyprina Grease 3 XSG-6280 Code 71-003	Shell Oil Co., 50 West 50th Street, New York, New York 10020
Lubricating Grease, Plug, Valve, Gasoline and Oil Resistant	MIL-G-6032 QPL-6032-10	Royco 32	Royal Engineering Co., Whippany, New Jersey
		Castrolase PV	Castrol Oils Inc., Newark, New Jersey
		Parker Fuel Lube 44	Parker Seal Co.
		BP Aero Grease 32	BP Trading Limited Moore Lane, Britannic House London E.C. 2 England
Anti-Seize Compound Graphite Petroleum	MIL-T-5544 TT-S-1732 (TT-A-580)	Royco 44	Royal Lubricants Co., River Road, Hanover, New Jersey 07936
Silicone Compound	MIL-S-8660 (MIL-C-21567) QPL-8660-7	DC-4, DC-6 Compound	Dow Corning, S. Saginaw Road, Midland, Michigan 48641
		G-624	General Electric Co., Silicone Products Dept., Waterford, New York 12188

Reissued: 10/11/79

1C19

HANDLING AND SERVICING

PIPER SENECA II SERVICE MANUAL

TABLE II-IV. LIST OF CONSUMABLE MATERIAL (cont.)

MATERIAL	SPECIFICATION	BRAND NAME	MANUFACTURER
Dry Lubricant, Fluorocarbon Release Agent	MIL-L-60326	Y-2900	Union Carbide
Waterproof Grease, High and Low Temperature		MS-122, 607S	
Sealer		Aero Lubriplate	
Solvent PD680	TT-T-548	PR 1321 B½	Products Research Co. 2919 Empire Avenue Burbank, Cal. 91504
Tuluol			
Buffing and Rubbing Compounds		Automotive Type- DuPont #7	Dupont Company Wilmington, Del. 19898
		Ram Chemical #69 x 1	Ram Chemicals Gardena, Cal. 90248
		Mirror Glaze #1	Mirror Bright Polish Co., Inc. Irvin, Cal. 92713
Cleaners		Fantastic Spray Perchloroethylene VM&P Naphtha (Lighter Fluid)	Local Suppliers
ABS-Solvent Cements		Solarite #11 Series	Solar Compounds Corp. Linden, N.J. 07036
Solvents	Methylethyl Ketone Methylene Chloride Acetone	Local Suppliers	
Rain Repellent		Repcon FSCM 50159	Unelko Corporation 727 E. 110th Street Chicago, Illinois 60628

PIPER SENECA II SERVICE MANUAL

TABLE II-IV. LIST OF CONSUMABLE MATERIALS (cont)

MATERIAL	SPECIFICATION	BRAND NAME	MANUFACTURER
Epoxy Patching Compound		Solarite #400	Solar Compounds Corp. Lindon, N. J. 07036
Hot Melt Adhesives Polyamids and Hot Melt Gun	Stick Form 1/2 in. dia. 3 in. long		Sears Roebuck & Co. or Most Hardware Stores
Sealant		PRC5000	Behr-Manning Division Norton
Tapes, Vinyl Foam	1/8 in. x 1 in.	510 Series, Type II	Norton Tape Division Troy, New York
Black Vinyl Plastic	2 in. x 9 mil. and/or 1 1/2 in. x 9 mil.		Norton Tape Division Troy, New York
Vinyl Foam	1 in. x 1/8 in.	530 Series, Type I	Norton Tape Division Troy, New York
Fuel Anti-Icing Additive	MIL-I-27686E	PFA-55MB	Phillips Petroleum Company, Bartlesville, Oklahoma 74004
		PRIST	Houston Chemical Company Div. of PPG Industries One Gateway Center Pittsburgh, Pa. 15222
Adhesives (Snubber and Rubber Type Parts)		Carboline F-1	Carboline Company 328 Hanley Ind. Ct. St. Louis, Missouri 63144
		Scotch Grip 2210	3M Company, Adhesives Coatings and Sealers Div. 3M Center, St. Paul Minnesota, 55101
		Proco Adhesives 6205-1	Protective Coatings Inc. 807 N. Fremont Ave. Tampa, Florida

NOTES:

1. Precautions should be taken when using MIL-G-23827 and MIL-G-81322, since these greases contain chemicals harmful to painted surfaces.

Revised: 3/16/81

1C21

HANDLING AND SERVICING

1C22
INTENTIONALLY LEFT BLANK

SECTION III

INSPECTION

Paragraph		Aerofich. Grid No.
3-1.	Introduction	1C24
3-2.	Recommended Lubricants	1C24
3-3.	Inspection Periods	1C24
	3-4. Inspection Requirements	1C24
	3-5. Preflight Check	1C24
	3-6. Overlimits Inspection	ID1
3-7.	Special Inspections	ID1
3-8.	Programmed Inspection	ID1

Revised: 8/10/80

1C23

SECTION III

INSPECTION

3-1. **INTRODUCTION.** This section provides instructions for conducting inspections. These inspections are described in Paragraphs 3-4 and 3-5. Repair or replacement instructions for those components found to be unserviceable at inspection may be found in the section covering the applicable aircraft system.

CAUTION

When working on engines, ground the magneto primary circuit before performing any operation.

3-2. **RECOMMENDED LUBRICANTS.** Refer to Recommended Lubricants, Section II for Lubrication Servicing Instructions.

3-3. **INSPECTION PERIODS.**

3-4. **INSPECTION REQUIREMENTS.** The required inspection procedures are listed in Table III-I. The inspection procedure is broken down into major groups which include Propeller, Engine, Cabin, Fuselage and Empennage, Wing, Landing Gear, Engine Run-up Inspection and General. The first column in each group lists the inspection or procedure to be performed. The second column is divided into four columns indicating the required inspection intervals of 50 hours, 100 hours, 500 hours and 1000 hours. Each inspection or operation is required at each of the inspection intervals as indicated by a circle (O). If an item is not entirely accessible or must be removed, refer to the applicable section of this manual for instructions on how to gain access to remove the item. When performing inspections, use inspection forms furnished by the Piper Factory Service Department available through Piper Dealers or Distributors, No. 230 856.

NOTE

In addition to inspection intervals required in Table III-I a preflight check must be performed as described in Paragraph 3-5.

3-5. **PREFLIGHT CHECK.** The airplane must be given a thorough preflight and walk-around check. The pilot and/or mechanic must include the preflight check as a normal procedure necessary for the safe operation of the aircraft. Refer to the Pilot's Operating Handbook for a listing of items that must be checked.

3-6. OVERLIMITS INSPECTION. If the airplane has been operated so that any of its components have exceeded their maximum operational limits, check with the appropriate manufacturer.

3-7. SPECIAL INSPECTIONS. The special inspections given in the following paragraphs supplement the scheduled inspections as outlined in the Inspection Report, Table III-I, to include inspection of items which are required to be examined at intervals not compatible with airframe operating time or airframe inspection intervals. Typical of this type are:

- a. Inspections required because of special conditions or incidents that arise and because of these conditions or incidents an immediate inspection would be required to insure further safe flight.
- b. Inspection of airframe or components on a calendar basis. This type of inspection could often be accomplished during the nearest scheduled inspection.
- c. Specific definitive inspection on engines based strictly upon engine operating time.
- d. Those inspections not completely covered in other sections of this manual but outlined in the Inspection Report and must be explained in more detail to give a clearer and complete inspection.

3-8. PROGRAMMED INSPECTION. The Programmed Inspection was designed to permit the utilization of the aircraft by scheduling inspections through the use of a planned inspection schedule. Programmed Inspection manuals are available from Piper Service Sales under Part No. 761 592.

*** PIPER SENECA II SERVICE MANUAL**

TABLE III-I. INSPECTION REPORT

—NOTE—

Perform all inspections or operations at each inspection intervals indicated by a circle (O). (See Notes 1, 2 and 3.)

Nature of Inspection	Inspection Time (HRS)					
	L	R	50	100	500	1000
A. PROPELLER						
1. Inspect spinner and back plate for cracks	O	O	O	O	O	O
2. Inspect blades for nicks and cracks	O	O	O	O	O	O
3. Check for grease and oil leaks	O	O	O	O	O	O
4. Lubricate propeller per lubrication chart (see note 10)	O	O	O	O	O	O
5. Inspect spinner mounting brackets for cracks	O	O		O	O	O
6. Inspect propeller mounting bolts and safety (check to see if safety is broken)	O	O		O	O	O
7. Inspect hub parts for cracks and corrosion	O	O		O	O	O
8. Rotate blades of constant speed propeller and check for tightness in hub pilot tube	O	O		O	O	O
9. Remove constant speed propeller; remove sludge from propeller and crankshaft	O	O			O	O
10. Inspect complete propeller and spinner assembly for security, chafing, cracks, deterioration, wear, and correct installation	O	O		O	O	O
11. Check propeller air pressure (at least once a month)	O	O	O	O	O	O
12. Overhaul Hartzell propeller per latest revision of Hartzell Service Letter 61	O	O				
13. Overhaul McCauley propeller per latest revision of McCauley Service Bulletin 137	O	O				
B. ENGINE GROUP						
WARNING: Read Note 24 before completing inspection.						
WARNING: Ground magneto primary circuit before working on engine.						
NOTE: Read Notes 6, 11, 25, and 26 before completing inspection.						
1. Remove engine cowl	O	O	O	O	O	O
2. Clean and inspect cowling for cracks, distortion, and loose or missing fasteners	O	O		O	O	O
3. Drain oil sump	O	O		O	O	O
4. Clean suction oil strainer at oil change (check strainer for foreign particles)	O	O		O	O	O
5. Change full flow (spin on type) oil filter element (check element for foreign particles) (check oil level after installing new filter)	O	O	O	O	O	O
6. Check oil temperature sender unit for leaks and security	O	O		O	O	O
7. Inspect oil lines and fittings for leaks, security, chafing, dents and cracks (see Notes 6 and 26)	O	O	O	O	O	O

IR

IR

*** PIPER SENECA II SERVICE MANUAL**

TABLE III-I. INSPECTION REPORT (cont.)

Nature of Inspection	Inspection Time (HRS)					
	L	R	50	100	500	1000
B. ENGINE GROUP (cont.)						
8. Clean and check oil radiator cooling fins.....	O	O		O	O	O
9. Fill engine with oil per information on cowl or Lubrication Chart.....	O	O		O	O	O
10. Clean engine.....	O	O	O	O	O	O
CAUTION: Use caution not to contaminate pressure pump with cleaning fluid.						
11. Check condition of spark plugs (Clean and adjust gap as required, see Note 9).....	O	O		O	O	O
12. Check cylinder compression (See Note 7).....	O	O		O	O	O
13. Inspect ignition harness and insulators (High tension leakage and continuity, see Notes 9 and 2-3).....	O	O	O	O	O	O
14. Check magneto points for proper clearance (Maintain clearance at .018 +006) (See Note 9).....	O	O		O	O	O
15. Inspect magneto for oil seal leakage.....	O	O		O	O	O
16. Check breaker felts for proper lubrication.....	O	O		O	O	O
17. Inspect distributor block for cracks burned areas or corrosion, and height of contact springs.....	O	O			O	O
18. Check magnetos to engine timing.....	O	O		O	O	O
19. Overhaul or replace magnetos (See Note 8).....	O	O				
20. Remove air filters and tap gently to remove dirt particles (Replace as required).....	O	O	O	O	O	O
21. Clean injector nozzles as required (Clean with acetone only).....	O	O	O	O	O	O
22. Replace pump air inlet filter, left and right (See Note 13).....	O	O		O	O	O
23. Replace gyro air inline filter, left and right (See Note 13).....	O	O			O	O
24. Remove induction air box valve and inspect for evidence of excessive wear or cracks. Replace defective parts.....	O	O		O	O	O
25. Inspect fuel injector attachments for loose hardware.....	O	O		O	O	O
26. Inspect engine primer system for operation, security, and leaks. (See Note 27).....	O	O		O	O	O
27. Check intake seals for leaks and clamps for tightness.....	O	O		O	O	O
28. Inspect all air inlet duct hoses (Replace as required).....	O	O		O	O	O
29. Inspect condition of flexible fuel lines.....	O	O		O	O	O
30. Replace flexible fuel lines (See Notes 11 and 26).....	O	O				O
31. Inspect fuel system for leaks (See Note 17).....	O	O		O	O	O
32. Check condition and operation of fuel pumps (engine driven and electric).....	O	O		O	O	O
33. Overhaul or replace engine driven fuel pumps (See Note 8).....	O	O				
34. Overhaul or replace electric fuel pump as required.....	O	O				
35. Inspect pressure pumps and lines.....	O	O		O	O	O
36. Overhaul or replace pressure pump (See Note 8).....	O	O				

Revised: 12/08/83

Interim Revision: 02/05/97

INSPECTION

*** PIPER SENECA II SERVICE MANUAL**

TABLE III-I. INSPECTION REPORT (cont.)

Nature of Inspection	Inspection Time (HRS)					
	L	R	50	100	500	1000
B. ENGINE GROUP (cont.)						
37. Check throttle, alternate air, mixture and propeller governor controls for security, travel and operating condition.....	O	O		O	O	O
38. Inspect exhaust stacks, connections and gaskets (Replace gaskets as required)	O	O	O	O	O	O
39. Inspect breather tubes for obstructions and security	O	O		O	O	O
40. Inspect crankcase for cracks, leaks and security of seam bolts	O	O		O	O	O
41. Inspect engine mounts for cracks and loose mountings	O	O		O	O	O
42. Check rubber ending mount bushings for deterioration (Replace as required)	O	O		O	O	O
43. Inspect all engine baffles	O	O		O	O	O
44. Inspect fire wall seals	O	O		O	O	O
45. Inspect condition of alternator and starter	O	O		O	O	O
46. Inspect all lines, air ducts, electrical leads and engine attachments for security, proper routing, chafing cracks, deterioration and correct installation.....	O	O	O	O	O	O
47. Check air conditioning compressor oil level (See Note 19).....	O			O	O	O
48. Check condition and tension of compressor drive belt (Refer to Service Manual, Section XIV)	O			O	O	O
49. Check security of compressor mounting	O			O	O	O
50. Inspect compressor clutch security and condition of wiring.	O			O	O	O
51. Lubricate all controls (See Note 10).....	O	O		O	O	O
52. Overhaul or replace propeller governor (Refer to latest revision of Hartzell Service Letter No. 61)	O	O				
53. Complete overhaul of engine or replace with factory rebuilt (See Note 8)	O	O				
54. Check magneto to RPM drop	O	O	O	O	O	O
55. Check full power RPM	O	O	O	O	O	O
56. Check full power manifold pressure.....	O	O	O	O	O	O
57. Check full power fuel flow.....	O	O	O	O	O	O
58. Check idle RPM and mixture	O	O	O	O	O	O
59. Inspect and clean oil pressure relief valve.....	O	O		O	O	O
60. Check unmetered fuel pressure at idle.....	O	O		O	O	O
61. Reinstall engine cowl	O	O	O	O	O	O

TABLE III-I. INSPECTION REPORT (cont.)

Nature of Inspection	Inspection Time (hrs)					
	L	R	50	100	500	1000
C. TURBOCHARGER GROUP						
1. Inspect all air inlet ducting and compressor discharge ducting for worn spots, loose clamps or leaks	O	O	O	O	O	O
2. Inspect engine air inlet assembly for cracks, loose clamps and screws	O	O	O	O	O	O
3. Inspect exhaust ducting and exhaust stacks for signs of leaks or cracks. Check all clamps for tightness	O	O	O	O	O	O
4. Carefully check all turbo support brackets, struts, etc., for breakage, sagging or wear	O	O	O	O	O	O
5. Inspect all oil lines and fittings for wear, leakage, heat damage or fatigue	O	O	O	O	O	O
6. Inspect bypass valve for security and safety	O	O	O	O	O	O
7. Run up engines, check all instruments for smooth, steady response	O	O	O	O	O	O
8. Remove all turbocharger components from the engine. Inspect and repair or replace as necessary. Check turbocharger rotor for excessive play, carbon and dirt deposits. See Troubleshooting Section for Rotor Play Limits. Remove turbine and compressor housings. Inspect turbine wheel and impeller for physical damage and excessive build up of deposits. If excessive, replace Turbocharger Assembly	O	O				O

*** PIPER SENECA II SERVICE MANUAL**

TABLE III-I. INSPECTION REPORT (cont.)

Nature of Inspection	Inspection Time (HRS)			
	50	100	500	1000
D. CABIN GROUP				
1. Inspect cabin entrance doors, cargo and baggage doors for damage and operation. Check condition and security of locks, latches and hinges. (See latest revision of Piper Service Bulletins 633 and 872.).....		0	0	0
2. Inspect windows for condition and security.		0	0	0
3. Inspect upholstery for tears.....		0	0	0
4. Inspect seats, seat belts, security brackets and bolts.....		0	0	0
5. Check trim system operation.....		0	0	0
6. Check operation and condition of rudder pedals.....		0	0	0
7. Check parking brake handle and toe brakes for operation and cylinder leaks.....		0	0	0
8. Check operation and condition of control wheels, column pulleys, bobweight and cables.....		0	0	0
9. Inspect flap control cable attachment bolt (See latest revision of Piper Service Bulletin 965).....		0	0	0
10. Inspect landing, navigation, cabin and instrument lights.....	0	0	0	0
11. Inspect instruments, lines and attachments (See latest revision of Piper Service Bulletin 584).....		0	0	0
12. Inspect gyro operated instruments and electric turn and bank (Overhaul or replace as required).....		0	0	0
13. Replace filters on gyro horizon and directional gyro or replace central air filters (where applicable) (See Note 13).....		0	0	0
14. Inspect altimeter (Calibrate system in accordance with FAR 91.170 if appropriate).....		0	0	0
15. Perform pitot-static tests if appropriate (Refer to FAR 91.170).....		0	0	0
16. Check operation of fuel selector valves.....		0	0	0
17. Check operation of fuel drains.....		0	0	0
18. Check condition and operation of heater controls and ducts.....		0	0	0
19. Check condition and operation of air vents.....		0	0	0
20. Inspect condition of air conditioning ducts.....		0	0	0
21. Remove and clean air conditioning evaporator filter.....		0	0	0
22. Inspect stabilator control stops to insure stop has not loosened and jam nuts are tight.....		0	0	0
23. Inspect rudder control stop to insure stop has not loosened and locknuts are tight.....		0	0	0
E. FUSELAGE AND EMPENNAGE GROUP				
1. Remove inspection plates and panels.....		0	0	0
2. Inspect battery box and cables (Check at least every 30 days. Flush box as required and fill battery per instructions on box).....	0	0	0	0
3. Check fluid level in brake reservoir (Fill as required).....	0	0	0	0
4. Inspect electronics installations for security (See latest revision of Piper Service Bulletin 553).....		0	0	0
5. Inspect antenna mounts and wiring for security and condition.....		0	0	0

Revised: 12/08/83

Interim Revision: 02/05/97

INSPECTION

PIPER SENECA II SERVICE MANUAL

TABLE III-I. INSPECTION REPORT (cont.)

Nature of Inspection	Inspection Time (hrs)			
	50	100	500	1000
E. FUSELAGE AND EMPENNAGE GROUP (cont.)				
6. Inspect bulkheads and stringers for damage		O	O	O
7. Inspect hydraulic pump motor brushes (See Note 16)		O	O	O
8. Check hydraulic pump fluid level (Fill as required)	O	O	O	O
9. Inspect hydraulic lines for damage and leaks		O	O	O
10. Check air conditioning system for freon leaks		O	O	O
11. Check freon level in sight gauge of receiver-dehydrator (Refer to Service Manual, Section XIV)	O	O	O	O
12. Inspect air conditioner condenser air scoop rigging	O	O	O	O
13. Inspect heater (See Note 18 for overhaul information)	O	O	O	O
14. Check fuel lines, valves and gauges for damage and operation		O	O	O
15. Check security of all lines		O	O	O
16. Inspect vertical fin and rudder surface for damage		O	O	O
17. Inspect rudder hinges, horn and attachments for damage and operation (Refer to the latest revision of Piper Service Bulletin No. 699)		O	O	O
18. Inspect vertical fin attachments for condition and security (See latest revision of Piper Service Bulletin No. 579)		O	O	O
19. Inspect ELT installation and condition of battery and antenna (See latest revision of Piper Service Letter No. 820)	O	O	O	O
20. Inspect rudder tab hinge bolts for excess wear (Replace as required) (See Note 13)		O	O	O
21. Inspect rudder trim mechanism (See Note 14)		O	O	O
22. Inspect stabilator surfaces for damage		O	O	O
23. Inspect stabilator, tab hinges, horn and attachments for damage and operation		O	O	O
24. Check condition of stabilator attachment (See latest Piper Service Bulletins 579 and 856)		O	O	O
25. Inspect stabilator and tab hinge bolts and bearings for excess wear (Replace as required)		O	O	O
26. Check condition and operation of stabilator trim mechanism		O	O	O
27. Check all cable tensions (use tensiometer) (See Note 15)		O	O	O
28. Inspect aileron, rudder, stabilator, stabilator trim cables, turnbuckles, guides and pulleys for condition, damage, safety, tension and operation		O	O	O
29. Inspect all control cables, electrical leads, air ducts, and attaching parts for security, routing, chafing, deterioration, wear and correct installation (Refer to the latest revision of Piper Service Bulletin No. 555)		O	O	O
30. Clean and lubricate stabilator trim screw (See Note 10)			O	O
31. Clean and lubricate all exterior needle bearings				O

Revised: 12/08/83
Interim Revision: 5/6/87

TABLE III-1. INSPECTION REPORT (cont.)

Nature of Inspection	Inspection Time (hrs)			
	50	100	500	1000
E. FUSELAGE AND EMPENNAGE GROUP (cont.)				
32. Lubricate per Lubrication Chart (See Note 10).....	O	O	O	O
33. Inspect strobe lights for security and operation		O	O	O
34. Check condition and security of autopilot bridle cable clamps		O	O	O
35. Reinstall inspection plates and panels.....		O	O	O
36. Inspect aileron control stops to insure stop has not loosened and lock nut is tight.....		O	O	O
F. WING GROUP				
1. Remove inspection plates and fairings		O	O	O
2. Inspect surfaces and tips for damage, loose rivets and condition of walkway		O	O	O
3. Inspect aileron hinges and attachments		O	O	O
4. Inspect aileron cables, pulleys, and bellcrank for damage and operation		O	O	O
5. Inspect flaps and attachments for damage and operation		O	O	O
6. Inspect condition of bolts used with hinges (Replace as required).....		O	O	O
7. Lubricate per Lubrication Chart (See Note 10).....	O	O	O	O
8. Inspect wing attachment bolts, nuts and brackets for security and condition		O	O	O
9. Inspect all control cables, electrical leads, air ducts, lines and attaching parts for security, routing, chafing, deterioration, wear and correct installation		O	O	O
10. Inspect fuel tanks and lines for leaks and water (See Note 11)		O	O	O
11. Remove, drain and clean fuel filter bowls (Drain and clean at least every 90 days)	O	O	O	O
12. Ascertain that fuel tanks are marked for minimum octane rating and capacity		O	O	O
13. Inspect condition of fuel tank vents (See Note 12).....		O	O	O
14. Reinstall inspection plates and fairings.....		O	O	O
G. LANDING GEAR GROUP				
1. Check oleo struts for proper extension (Check for proper fluid level and air pressure as required)	O	O	O	O
2. Check nose gear steering control and travel		O	O	O
3. Check wheel alignment		O	O	O
4. Put airplane on jacks (Refer to Section II of Service Manual)		O	O	O
5. Inspect tires for cuts, uneven or excessive wear and slippage		O	O	O
6. Remove wheels, clean, inspect and repack bearings		O	O	O

*** PIPER SENECA II SERVICE MANUAL**

TABLE III-I. INSPECTION REPORT (cont.)

Nature of Inspection	Inspection Time (HRS)			
	50	100	500	1000
G. LANDING GEAR GROUP (cont.)				
7. Inspect wheels for cracks, corrosion and broken belts.....		0	0	0
8. Check tire pressure (Refer to Section II, Table II-I).....	0	0	0	0
9. Inspect condition of brake linings and disc (Refer to Section VII, Paragraph 7-52)				
10. Inspect condition of brake backing plates		0	0	0
11. Inspect condition and security of brake lines and retaining clamps		0	0	0
12. Inspect condition of center spring and bungees.....		0	0	0
13. Inspect gear forks for damage		0	0	0
14. Inspect oleo struts for fluid leaks and scoring.		0	0	0
15. Inspect gear struts, attachment, torque links, retraction links and bolts for condition and security (See Note 20).....		0	0	0
16. Check downlocks for operation and adjustment.....		0	0	0
17. Inspect torque link bolts and bushings (Rebush as required)		0	0	0
18. Inspect drag end side brace link bolts (Replace as required)		0	0	0
19. Inspect nose gear upper drag link AN7-35 attach bolt		0		
20. Replace nose gear upper drag link AN7-35 attach bolt.....			0	0
21. Inspect gear doors and attachments for condition and security		0	0	0
22. Check operation of gear warning horn and light		0	0	0
23. Retract gear - check operation and gear doors for clearance.....		0	0	0
24. With gear retracted, check "Free Fall" valve operation.....		0	0	0
25. Check operation of squat switch.....		0	0	0
26. Check downlock switches, up switches and electrical leads for operation, condition and security of mounting		0	0	0
27. Inspect all hydraulic lines, electrical leads, and attaching parts for security, routing, chafing, deterioration, wear and correct installation (See the latest revision of Piper Service Letter No. 808)		0	0	0
28. Lubricate per Lubrication Chart (See Note 9)	0	0	0	0
29. Ascertain landing gear is down and locked; then remove airplane from jacks		0	0	0

***PIPER SENECA II SERVICE MANUAL**

TABLE III-I. INSPECTION REPORT (cont.)

Nature of Inspection	Inspection Time (hrs)			
	50	100	500	1000
H. OPERATIONAL INSPECTION				
1. Check fuel pumps, fuel tank selector and crossfeed operation	O	O	O	O
2. Check fuel quantity and pressure or flow gauges	O	O	O	O
3. Check oil pressure and temperature gauges	O	O	O	O
4. Check alternator output - left and right engines	O	O	O	O
5. Check manifold pressure gauge	O	O	O	O
6. Check alternate air	O	O	O	O
7. Check parking and toe brake	O	O	O	O
8. Check pressure gauge	O	O	O	O
9. Check gyro for noise and roughness	O	O	O	O
10. Check cabin heater and defroster	O	O	O	O
11. Check magneto RPM variation	O	O	O	O
12. Check magneto switch operation	O	O	O	O
13. Check throttle and mixture controls	O	O	O	O
14. Check propeller controls and propeller action	O	O	O	O
15. Check engine idle	O	O	O	O
16. Check electronic equipment operation (Refer to Section XII of Service Manual for ELT check)	O	O	O	O
17. Check air condition compressor clutch operation	O	O	O	O
18. Check air conditioner condenser scoop operation	O	O	O	O
19. Check operation of flight controls and flaps	O	O	O	O
20. Check operation of Autopilot, including automatic pitch trim and manual electric trim (See Note 22)	O	O	O	O
I. GENERAL				
1. Aircraft conforms to latest FAA Specifications	O	O	O	O
2. All latest FAA Airworthiness Directives complied with	O	O	O	O
3. All latest revisions of Manufacturers Service Letters and Bulletins complied with	O	O	O	O
4. Check for proper Flight Manual	O	O	O	O
5. Aircraft papers in proper order	O	O	O	O

* PIPER SENECA II SERVICE MANUAL

NOTES:

1. Refer to the last card of the Piper Parts Price List - Aerofiche, for a checklist of current revision dates to Piper inspection reports and manuals.
2. All inspections or operations are required at each of the inspection intervals as indicated by an (O). Both the annual and 100 hour inspections are complete inspections of the airplane, identical in scope, while both the 500 and 100 hour inspections are extensions of the annual or 100 hour inspections, which require a more detailed examination of the airplane, and overhaul or replacement of some major components. Inspections must be accomplished by persons authorized by the FAA.
3. Piper service bulletins are of special importance and Piper considers compliance mandatory.
4. Piper service letters are product improvements and service hints pertaining to servicing the airplane and should be given careful attention.
5. Inspections given for the power plant are based on the engines manufacturer's operator's manual for the particular airplane. Any changes issued to the engine manufacturer's operator's manual shall supersede or supplement the inspections outlined in this report.
6. Replace flexible oil lines as required, but not to exceed 1000 hours or 8 years, the first to occur. In addition, replace lines at engine overhaul.
7. Refer to the latest revision of Continental Motors Service Bulletin M73-19.
8. Replace or overhaul as required or at engine overhaul. Refer to the latest revision of Continental Motors Service Bulletin M74-20.
9. For operation at higher altitudes (12,000 feet and up), more frequent ignition system maintenance is required. (Refer to the latest revision of Continental Service Bulletin M78-8.)
10. Refer to lubrication chart.
11. Replace flexible fuel supply hose and interconnect hose couplings as required, but not to exceed 1000 hours or 8 years, the first to occur. In addition, replace lines at engine overhaul.
12. Replace fuel tank vent line flexible connections as required, but not later than three years time in service.
13. Early Seneca's had inline filter in cabin; later models have filter located in nacelle.
14. Refer to section V, paragraph 5-34 for allowable rudder tab and trim free play.
15. Maintain cable tensions specified in section V of service manual.
16. Inspect brushes every 100 hours if aircraft is used for training or 500 hours if aircraft is used for normal service (refer to service manual, section VI).
17. Refer to the latest revision of Piper Service Bulletin 596.
18. Conduct 100 hour inspections in accordance with Janitrol Maintenance and Overhaul Manual 24E25-1, dated October 1981. Overhaul any heater that does not pass the combustion pressure decay test outlined in the Janitrol Manual. Copies obtainable from: Janitrol Aero Division, Midland-Ross Corp., 4200 Surface Rd., Columbus, Ohio 43228.
19. The compressor oil level should not be checked unless a Freon leak has occurred which requires an addition of Freon to the system.
20. For all aircraft in excess of 1000 hours carefully inspect the trunnion forging barrel for cracks with a 10 power glass at the lower end of the fillet every 500 hours thereafter unless replaced by p/n 67926-12, 67926-13, 67926-14 or 67926-15.
21. Refer to section XII of service manual for appropriate subject manual part number.
22. Refer to flight manual supplement for preflight and flight check, for intended function in all modes.
23. Refer to the latest revision of Bendix Service Bulletin 612 for inspection of magnetos and ignition harness.
24. Refer to Teledyne Continental Service Bulletin M86-11, latest revision.
25. Refer to VSP 69.
26. Flexible hose replacement times are in-service times. In-service must be determined by (1) the date the aircraft was licensed, if new or (2) the date entered in the logbook for the replacement hose placed in service. Do not use the date stamped on the hose, as time may be included for shelf life, and not in-service use.
27. See latest revision of Piper Service Bulletin 905.

Interim Revision: 02/05/97

INSPECTION

1D11

Island Enterprises

SECTION IV

STRUCTURES

Paragraph		Aerofiche Grid No.
4-1.	Introduction	1D14
4-2.	Description	1D14
4-2a.	Standard Practices	1D14
	4-2b. Removal of Cherrylock Rivets	1D14
	4-2c. Identification of Fluid Lines	1D17
	4-2d. Flareless Tube Assemblies	1D17
	4-2e. Support Clamps Information	1D20
	4-2f. Electrical Bonding	1D20
4-3.	Wing Group	1D20
4-4.	Wing Tip	1D20
	4-5. Removal of Wing Tip	1D20
	4-6. Repair of Wing Tip	1D20
	4-7. Installatin of Wing Tip	1D21
4-8.	Aileron	1D21
	4-9. Removal of Aileron	1D21
	4-10. Installation of Aileron	1D21
4-11.	Wing Flap	1D21
	4-12. Removal of Wing Flap	1D21
	4-13. Installation of Wing Flap	1D21
4-14.	Wing	1D24
	4-15. Removal of Wing	1D24
	4-16. Installation of Wing	1E3
4-17.	Empennage Group	1E4
4-18.	Stabilator	1E4
	4-19. Removal of Stabilator	1E4
	4-20. Installation of Stabilator	1E5
4-21.	Stabilator Trim Tab	1E5
	4-22. Removal of Stabilator Trim Tab	1E5
	4-23. Installation of Stabilator Trim Tab	1E5
4-24.	Rudder	1E10
	4-25. Removal of Rudder	1E10
	4-26. Installation of Rudder	1E10
4-27.	Rudder Trim Tab	1E10
	4-28. Removal of Rudder Trim Tab	1E10
	4-29. Installation of Rudder Trim Tab	1E11
4-30.	Vertical Fin	1E11
	4-31. Removal of Vertical Fin	1E11
	4-32. Installation of Vertical Fin	1E12
4-33.	Fuselage Assembly	1E12
4-34.	Windshield	1E12
	4-35. Removal of Windshield	1E12
	4-36. Installation of Windshield	1E12

Revised: 8/10/80

Paragraph

Aerofiche
Grid No.

4-37.	Side Windows	1E14
4-38.	Removal of Windows (Side)	1E14
4-39.	Installation of Windows (Side)	1E14
4-40.	Removal of Rear Door Window	1E15
4-41.	Installation of Rear Door Window	1E15
4-42.	Door (Entrance)	1E17
4-42a.	Removal and Installation of Door Snubbers	1E17
4-43.	Removal of Door	1E20
4-44.	Installation of Door	1E20
4-45.	Adjustment of Door	1E21
4-46.	Removal of Door Latch Mechanism	1E21
4-47.	Installation of Door Latch Mechanism	1E21
4-48.	Adjustment of Door Latch Mechanism	1E21
4-49.	Removal of Door Lock Assembly	1E21
4-50.	Installation of Door Lock Assembly	1E21
4-51.	Removal of Door Safety (Auxiliary) Latch	1E21
4-52.	Installation of Door Safety (Auxiliary) Latch	1E21
4-53.	Adjustment of Door (Auxiliary) Latch	1E21
4-54.	Baggage Door	1E21
4-55.	Removal of Baggage Door	1E21
4-56.	Installation of Baggage Door	1E22
4-57.	Removal of Baggage Door Lock Assembly	1E22
4-58.	Installation of Baggage Door Lock Assembly	1E22
4-59.	Removal of Baggage Door Hinge	1E22
4-60.	Installation of Baggage Door Hinge	1E22
4-61.	Rigging Instructions - Seat Back Lock and Release	1E22
4-61a.	Shoulder Harness Inertia Reel Adjustment	1E22
4-62.	Structural Repairs	1E24
4-63.	Fiberglass Repairs	1E24
4-64.	Fiberglass Touch-Up and Surface Repairs	1E24
4-65.	Fiberglass Fracture and Patch Repairs	1F2
4-66.	Thermoplastic Repairs	1F5
4-67.	Safety Walk Repair	1F13
4-68.	Surface Preparation for Liquid Safety Walk	1F13
4-69.	Product Listing for Liquid Safety Walk Compound	1F13
4-70.	Application of Liquid Safety Walk Compound	1F13
4-71.	Surface Preparation for Pressure Sensitive Safety Walk	1F14
4-72.	Application of Pressure Sensitive Safety Walk	1F14
4-73.	Control Surface Balancing	1F15
4-74.	Checking Control Surface Balance	1F15
4-75.	Balancing Equipment	1F15
4-76.	Balancing Ailerons	1F17
4-77.	Balancing Rudder	1F17
4-78.	Balancing Stabilator	1F19
4-79.	Checking Free Play of Control Surfaces	1F19

SECTION IV
STRUCTURES

4-1. INTRODUCTION. This section explains the removal and installation procedures for the structural surfaces of the airplane. For the removal, installation, and rigging and adjustment procedures of the controlling components of the various structural surfaces, refer to Section V.

NOTE

When torquing structural assemblies, standard torque values are to be used as found in Section II or FAA Advisory Circular 43.13-1A, unless otherwise stated in this section.

4-2. DESCRIPTION. The PA-34-200T is an all metal semi-monocoque structure with an overall length of 28 feet 7.5 inches. The fuselage is constructed of bulkheads, stringers and stiffeners, to which all of the outer skin is riveted. Windows include a single pane windshield and eight side windows; all windows are single pane. A storm window is located in the forward lower section of the left window and can be opened inward when the latch is released. The cabin entrance door is located on the right side of the fuselage, above the wing, and is equipped with a safety latch on the top of the door which can be operated from the inside or outside. A door provided for entrance to the aft passenger compartment is located just aft of the left wing.

Each wing panel is an all metal, full cantilever semi-monocoque type construction with a removable fiberglass or thermoplastic tip. Installed in each wing ahead of the main spar are two metal fuel tanks with a capacity of 24.5 U.S. gallons each or 49.0 U.S. gallons total per wing. Attached to each wing is an aileron, flap, main landing gear and power plant. The wings are attached to each side of the fuselage by inserting the butt ends of the main spars into a spar box carry-through. The spar box is an integral part of the fuselage structure which provides, in effect, a continuous main spar with splices at each side of the fuselage. There are also fore and aft attachments at the front and rear spars.

The all metal empennage group is a full cantilever design consisting of a vertical stabilizer (fin), rudder and stabilator, all with removable fiberglass or thermoplastic tips. The rudder and stabilator have trim tabs attached that are controllable from the cockpit. The stabilator also incorporates one channel main spar that runs the full length of the stabilator and hinges to the aft bulkhead assembly of the fuselage. All exterior surfaces are coated with enamel or acrylic lacquer. As an option, the airplane may be completely primed with zinc chromate.

4-2a. STANDARD PRACTICES.

4-2b. REMOVAL OF CHERRYLOCK RIVETS. (Refer to Figure 4-1.) If necessity requires the removal of a cherrylock rivet, proceed as follows:

a. In thick material remove the lock by driving out the rivet stem, using a tapered steel drift pin. (See View I.)

NOTE

Do not drill completely through the rivet sleeve to remove a rivet as this will tend to enlarge the hole.

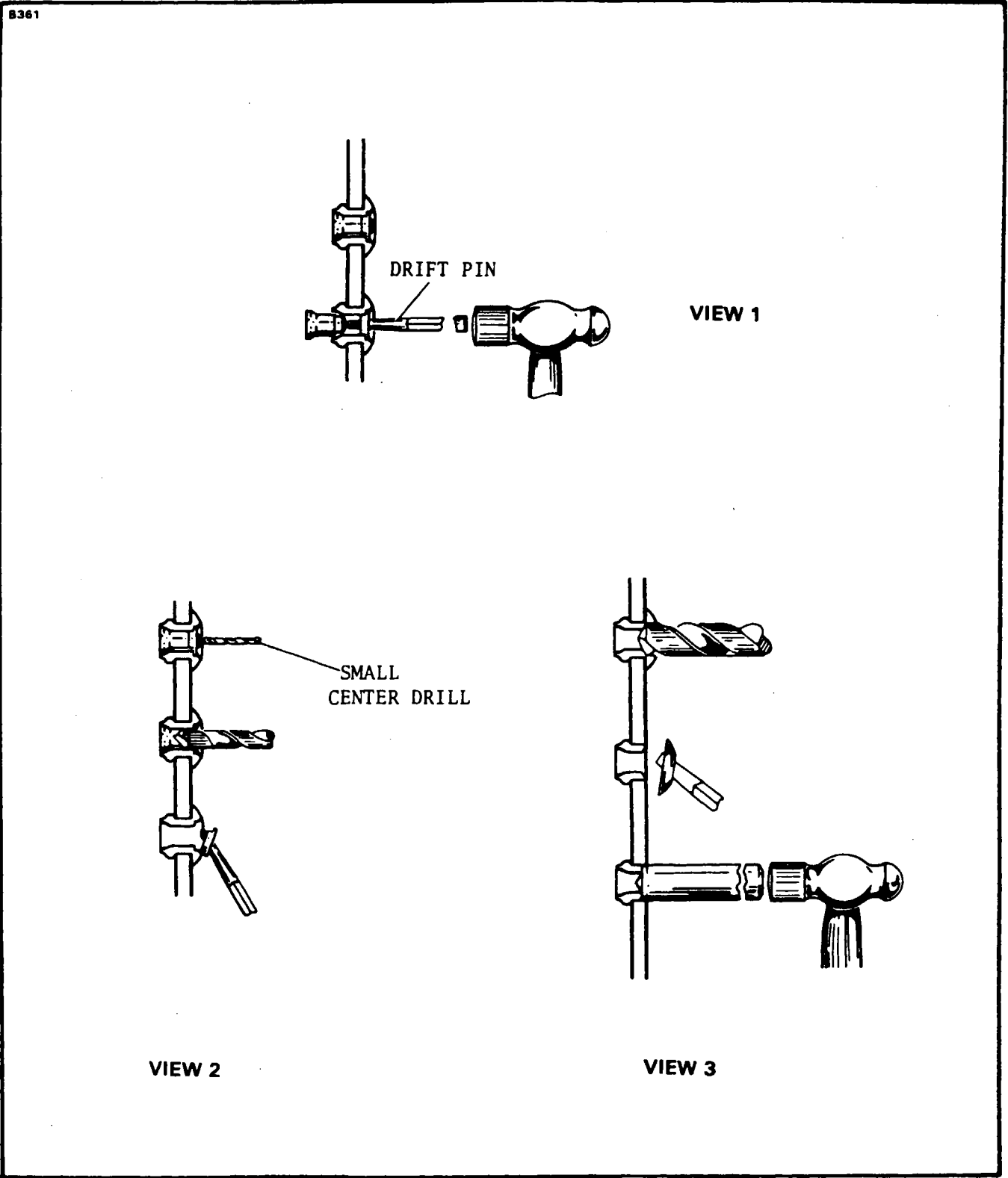

Figure 4-1. Cherrylock Rivet Removal

Added: 8/10/80

1D15

STRUCTURES

PIPER SENECA II SERVICE MANUAL

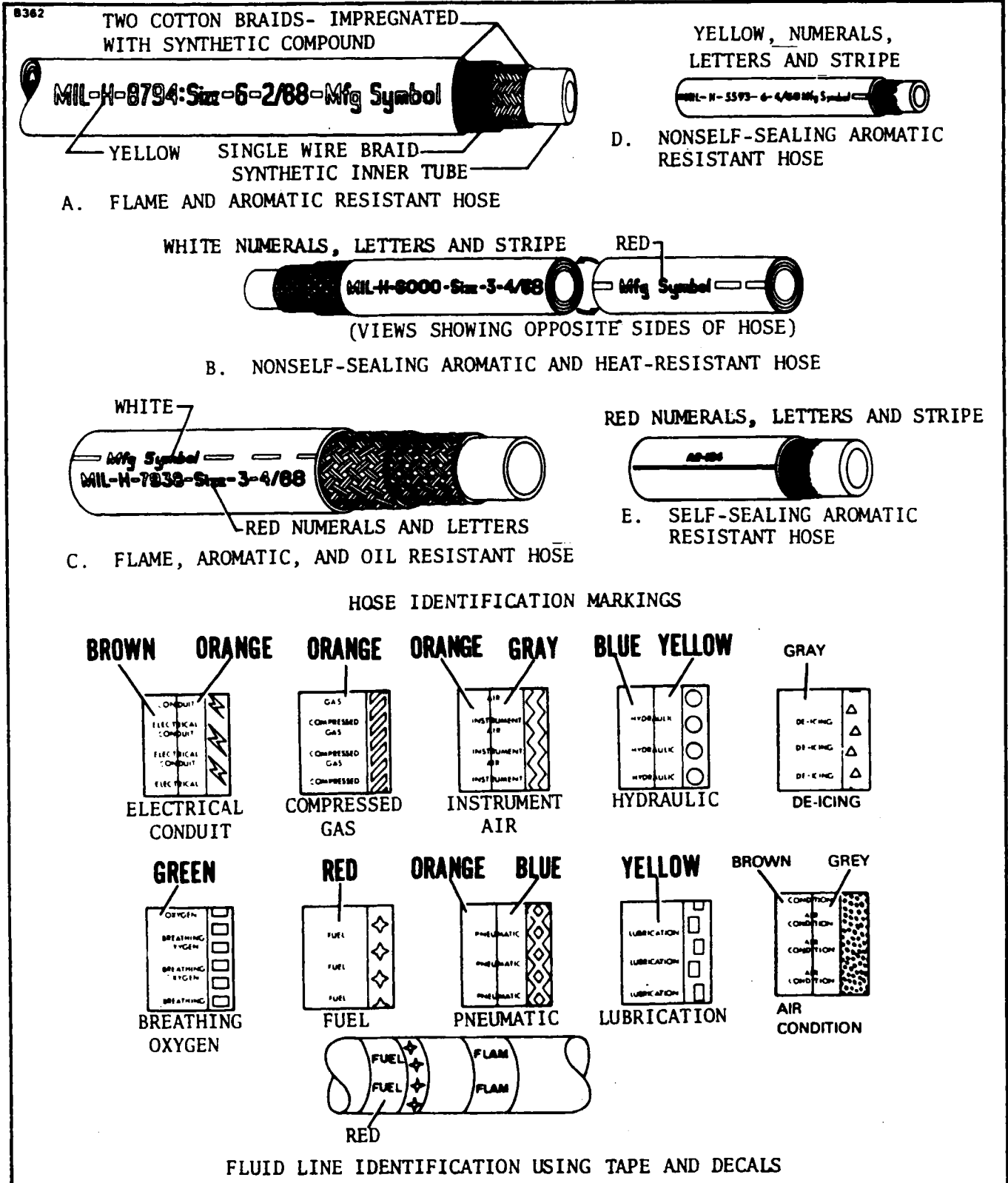

Figure 4-1a. Hose/Line Markings

Added: 8/10/80

STRUCTURES

- b. If the rivets have been installed in thin sheets, driving out the locked stem may damage the sheets. It is recommended that a small center drill be used to provide a guide for a larger drill on top of the rivet stem, and the tapered portion of the stem be drilled away to destroy the lock. (See View 2.)
- c. Pry the remainder of the locking collar out of the rivet head with the drift pin. (See View 2.)
- d. Drill nearly through the head of the rivet, using a drill the same size as the rivet shank. (See View 3.)
- e. Break off rivet head, using a drift pin as a pry. (See View 3.)
- f. Drive out the remaining rivet shank with a pin having a diameter equal to the rivet shank. (See View 3.)

4-2c. IDENTIFICATION OF FLUID LINES. (Refer to Figure 4-1a.) Fluid lines in aircraft are often identified by markers made up of color codes, words, and geometric symbols. These markers identify each line's function, content, and primary hazard, as well as the direction of fluid flow.

In most instances, fluid lines are marked with 1-inch tape or decals. Paint is used on lines in engine compartments, where there is the possibility of tapes, decals or tags being drawn into the engine induction system.

In addition to the above mentioned markings, certain lines may be further identified as to specific function within a system; for example, DRAIN, VENT, PRESSURE or RETURN.

Lines conveying fuel may be marked FLAM; lines containing toxic materials are marked TOXIC in place of FLAM. Lines containing physically dangerous materials, such as oxygen, nitrogen, or freon, are marked PHDAN.

The aircraft and engine manufacturers are responsible for the original installation of identification markers, but the aviation mechanic is responsible for their replacement when it becomes necessary.

Generally, tapes and decals are placed on both ends of a line and at least once in each compartment through which the line runs. In addition, identification markers are placed immediately adjacent to each valve, regulator, filter or other accessory within a line. Where paint or tags are used, location requirements are the same as for tapes and decals.

4-2d. FLARELESS-TUBE ASSEMBLIES. (Refer to Figure 4-1b.) Although the use of flareless-tube fittings eliminates all tube flaring, another operation, referred to as presetting, is necessary prior to installation of a new flareless-tube assembly which is preformed as follows:

- a. Cut the tube to the correct length, with the ends perfectly square. Deburr the inside and outside of the tube. Slip the nut, then the sleeve, over the tube (Step 1).

- b. Lubricate the threads of the fitting and nut. See Figure 4-1b for proper lubricant to use, depending on the type system the tubing assemblies are to be used on. Place the fitting in the vise (Step 2), and hold the tubing firmly and squarely on the seat in the fitting. (Tube must bottom firmly in the fitting.) Tighten the nut until the cutting edge of the sleeve grips the tube. This point is determined by slowly turning the tube back and forth while tightening the nut. When the tube no longer turns, the nut is ready for final tightening.

- c. Final tightening depends upon the tubing. For aluminum alloy tubing up to and including 1/2 inch outside diameter, tighten the nut from one to one and one-sixth turns. For steel tubing and aluminum alloy tubing over 1/2 outside diameter, tighten from one and one-sixth to one and one-half turns.

After presetting the sleeve, disconnect the tubing from the fitting and check the following points (illustrated in Step 3):

- a. The tube should extend 3/32 to 1/8 inch beyond the sleeve pilot; otherwise blowoff may occur.
- b. The sleeve pilot should contact the tube or have a maximum clearance of 0.005 inch for aluminum alloy tubing or 0.015 inch for steel tubing.
- c. A slight collapse of the tube at the sleeve cut is permissible. No movement of the sleeve pilot, except rotation is permissible.

PIPER SENECA II SERVICE MANUAL

8363

TUBING SYSTEM	LUBRICANT
HYDRAULIC	MIL-H-5606
FUEL	MIL-H-5606
OIL	System Oil
PNEUMATIC	MIL-L-4343
OXYGEN*	MIL-T-5542

*CAUTION-DO NOT USE OIL OR GREASE

TUBING AND HOSE LUBRICANTS

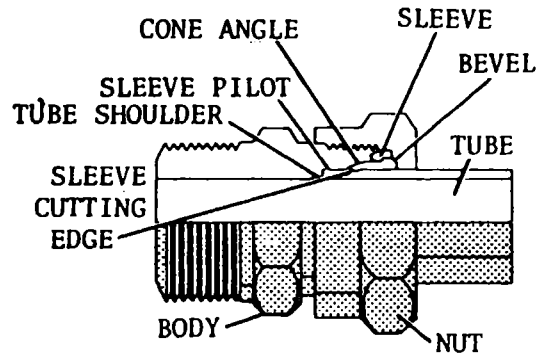

FLARELESS-TUBE FITTING

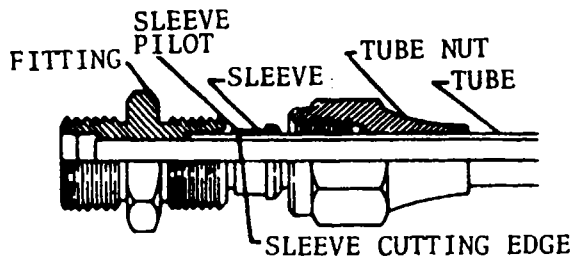

STEP 1

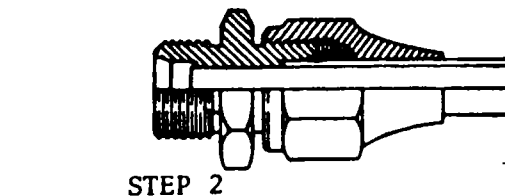
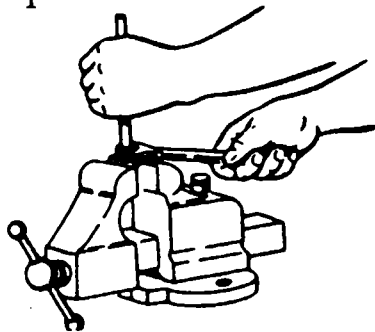

STEP 2

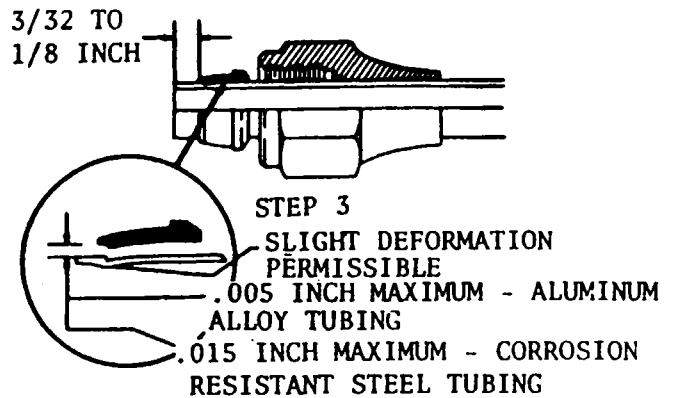

PRESETTING FLARELESS-TUBE ASSEMBLY

Figure 4-1b. Flareless-Tube Fittings

Added: 8/10/80

STRUCTURES

PIPER SENECA II SERVICE MANUAL

TABLE IV-I. MAXIMUM DISTANCES BETWEEN FLUID TUBING SUPPORTS

TUBE OD (IN.)	DISTANCE BETWEEN SUPPORTS (IN.)	
	ALUMINUM ALLOY	STEEL
1 8	9-1/2	11-1/2
3 16	12	14
1 4	13-1/2	16
5 16	15	18
3 8	16-1/2	20
1 2	19	23
5 8	22	25-1/2
3 4	24	27-1/2
1	26-1/2	30

TABLE IV-II. MAXIMUM RESISTANCE VALUES ALLOWED FOR ELECTRICAL BONDING

ITEM TO BE ELECTRICALLY BONDED	MAXIMUM ALLOWABLE RESISTANCE VALUE IN OHMS
Engine Mount	.003
Generators	.003
Ailerons	.003
Elevators	.003
Rudder	.003
Motor(s)	.003
Flaps	.003
Trim Tabs	
Conventional Hinge	.003
Piano Wire Hinge	.01
Instrument Panel Inserts	.01
Interior Lights	.01
Exterior Lights Mounted on Non-Conductive Material	.003
Heaters	.003
Electrical Equipment	.003
Avionics "Black Boxes"	.003
Battery Ground Point to Generator Ground Point	.01
Refueling Ground Attachment to Aluminum Plate under Tire (A/C on Ground)	10 Megohms

56008

Revised: 3/16/81

1D19

STRUCTURES

4-2e. SUPPORT CLAMPS INFORMATION. Support clamps are used to secure the various lines to the airframe or power plant assemblies. Several types of support clamps are used for this purpose. The rubber-cushioned and plain are the most commonly used clamps. The rubber-cushioned clamp is used to secure lines subject to vibration; the cushioning prevents chafing of the tubing. The plain clamp is used to secure lines in areas not subject to vibration.

A teflon-cushioned clamp is used in areas where the deteriorating effect of Skydrol 500, hydraulic fluid (MIL-H-5606) or fuel is expected, however, because it is less resilient, it does not provide as good a vibration-damping effect as other cushion materials.

Use bonded clamps to secure metal hydraulic, fuel and oil lines in place. Unbonded clamps should be used only for securing wiring. Remove any paint or anodizing from the portion of the tube at the bonding clamp location. Make certain that clamps are of the correct size. Clamps or supporting clips smaller than the outside diameter of the hose may restrict the flow of fluid through the hose.

All plumbing lines must be secured at specified intervals. The maximum distance between supports for rigid fluid tubing is shown in Table IV-I.

4-2f. ELECTRICAL BONDING. Aircraft electrical bonding should be accomplished or verified to establish a maximum allowable resistance value. See Table IV-II for values.

All electrical, electronic equipment and components shall be installed in such a manner as to provide a continuous low-resistance path from the equipment enclosure to the airplane structure.

Parts shall be bonded directly to the primary structure rather than to other bonded parts.

All parts shall be bonded with as short a lead as possible.

All bonding surfaces shall be cleaned prior to the installation of the bonded joint.

All nuts used in bonding shall be of the self-locking type. (Do Not use fiber-locking type.)

All electrical bonding shall be accomplished without affecting the structural integrity of the airframe.

Bond connections shall be secure and free from corrosion.

Self-Tapping Screws will not be used for bonding purposes.

4-3. WING GROUP.

NOTE

The major subassemblies of the wing may be removed individually or the wing may be removed as a unit. To remove a wing, a fuselage supporting cradle is required.

4-4. WING TIP.

4-5. REMOVAL OF WING TIP.

a. Remove the screws holding the wing tip to the wing being careful not to damage the wing or wing tip.

b. Pull off the wing tip far enough to disconnect the navigation light wire assembly. The ground lead may be disconnected at the point of connection on the wing rib and the positive lead may be disconnected at the wire terminal or unscrewed from the light assembly.

c. Inspect the fiberglass wing tip to ascertain that it is free of cracks, severe nicks and minor damage.

4-6. REPAIR OF WING TIP. Fiberglass wing tips may be repaired in accordance with fiberglass repair procedures in the structural repairs portion of this section. Badly damaged thermoplastic tips should be replaced.

4-7. INSTALLATION OF WING TIP.

a. Place the wing tip in a position that the navigation light leads may be connected. Connect the ground lead to the wing rib by use of a screw and nut and the positive lead to the navigation light by connecting the wire terminals or screwing the connectors together. Insulate the wire terminals and be certain that the ground lead is free of dirt and film to insure a good connection.

b. Insert the wing tip into position and install the screws around the tip. Use caution to refrain from damaging the wing tip or wing. Check operation of the navigation light.

4-8. AILERON.

4-9. REMOVAL OF AILERON. (Refer to Figure 4-1c.)

a. Disconnect the aileron control rod at the center hinge by removing the nut, washers, and bolt from the rod end bearing. To simplify installation, note the location of the washers.

b. Support the aileron and disconnect the inboard, outboard and center aileron hinges by removing the nuts, washers and hinge bolts. Remove the aileron by lifting and pulling aft.

4-10. INSTALLATION OF AILERON. (Refer to Figure 4-1c.)

a. Position the aileron in the wing and install the bolts, washers, and nuts at the hinges.

b. Connect the aileron control rod to the aileron at the center hinge brackets with bolt, washers and nut.

4-11. WING FLAP.

4-12. REMOVAL OF WING FLAP. (Refer to Figure 4-1c.)

a. Extend the flaps to their fullest degree and remove the bolt and bushing from the rod end bearing by use of an angle or offset screwdriver.

b. Remove the nuts, washers, bushing, and hinge bolts that hold the flap to the wing assembly.

c. Pull the flap straight back off the wing.

4-13. INSTALLATION OF WING FLAP. (Refer to Figure 4-1c.)

a. Replace the wing flap by placing the flap into its proper position and inserting the hinge bolts, bushings, washers and nuts.

b. With the flap control in the full flap position, place the bushing on the outboard side of the rod end bearing and insert and tighten the bolt.

c. Operate the flap several times to be certain it operates freely.

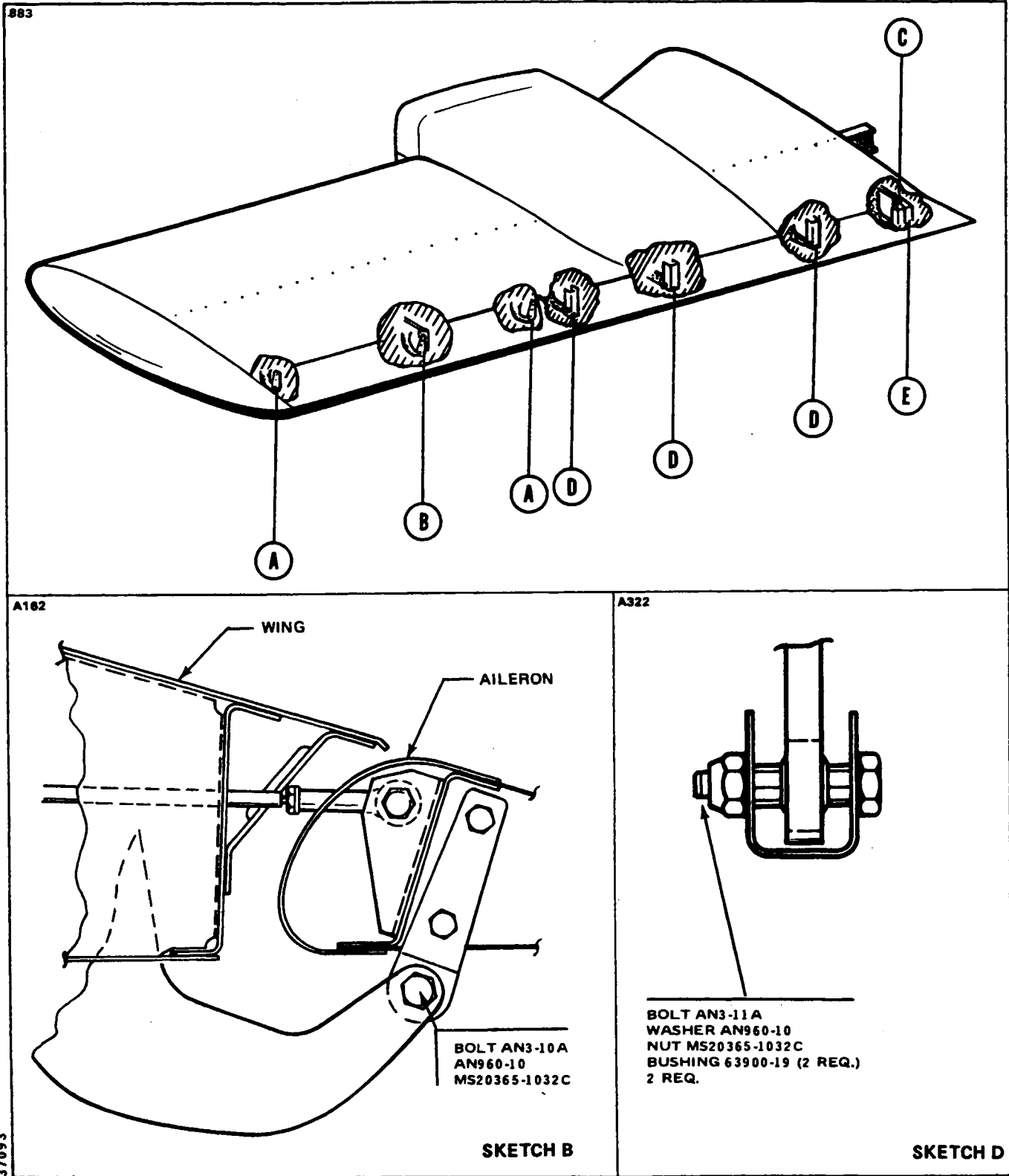

Figure 4-1c. Aileron and Flap Installation

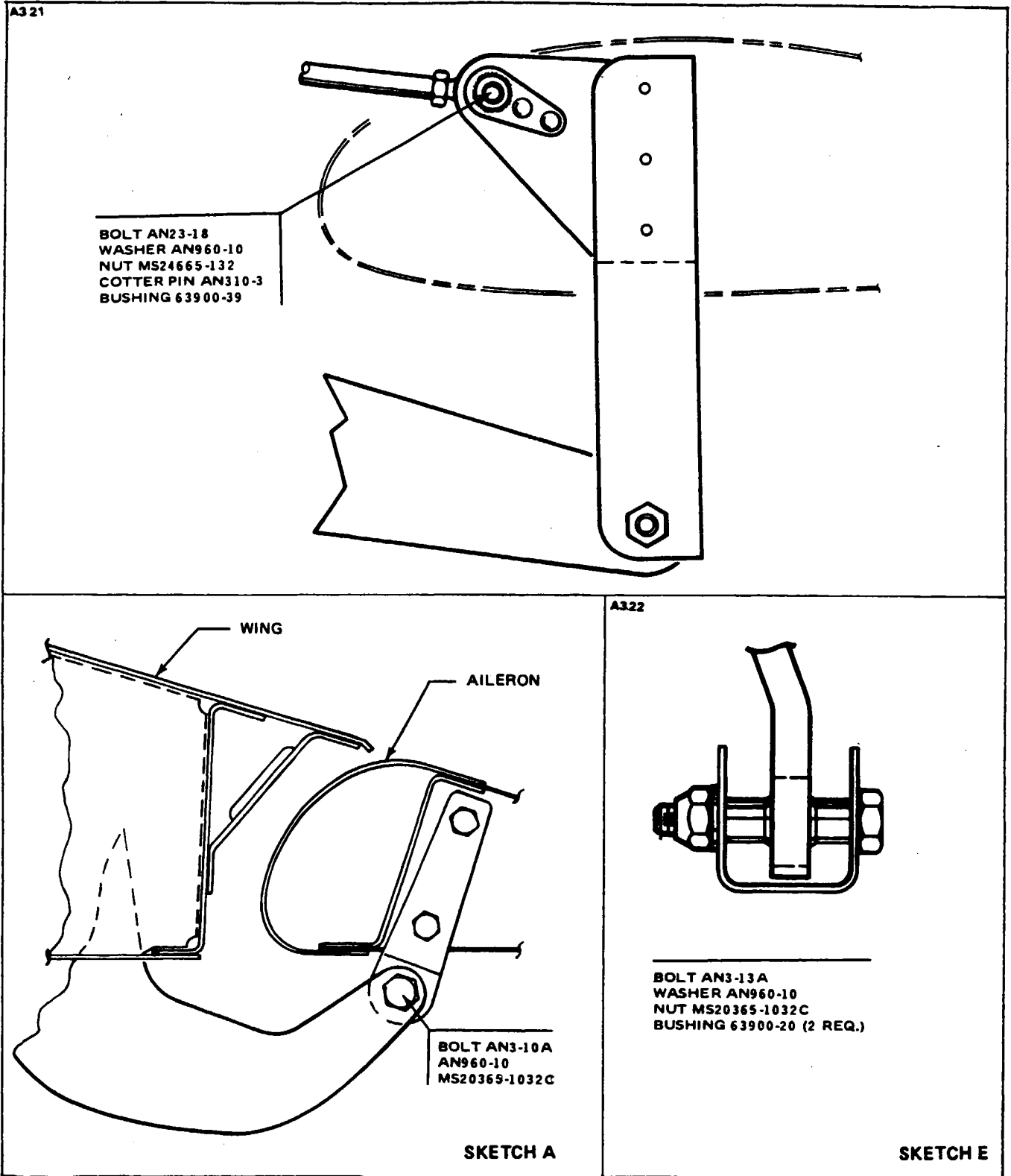

Figure 4-1c. Aileron and Flap Installation (cont.)

4-14. WING.

4-15. REMOVAL OF WING. (Refer to Figure 4-2.)

- a. Close the fuel valve and drain the fuel from the wing to be removed. (Refer to Draining Fuel System, Section II.)
- b. Drain the brake lines and reservoir. (Refer to Draining Brake System, Section II.)
- c. Remove the engine from the wing to be removed. (Refer to Removal of Engine, Section VIII.)
- d. Drain the hydraulic lines of the landing gear of the wing to be removed by separating the lines and elbows at the actuating cylinder.
- e. Remove the access plate at the wing butt rib and wing inspection panels. (Refer to Access Plates and Panels, Section II.)
- f. Remove the front and back seats from the airplane.
- g. Expose the spar box and remove the side trim cockpit panel assembly that corresponds with the wing being removed.
- h. Place the airplane on jacks. (Refer to Jacking, Section II.)

NOTE

To help facilitate reinstallation of control cables, power plant controls, and fuel and hydraulic lines, mark cable and line ends in some identifying manner and attach a line where applicable to cables before drawing them through the fuselage or wing.

- i. Disconnect the aileron balance and control cables at the turnbuckles that are located within the fuselage aft of the spar.
- j. If the left wing is being removed, remove the cotter pin from the pulley bracket assembly to allow the left aileron balance cable end to pass between the pulley and bracket.
- k. Disconnect the flap from the torque tube by extending the flap to its fullest degree and removing the bolt and bushing from the bearing at the aft end of the control rod.
- l. Disconnect the fuel line at the fitting located inside of the wing by removing the access panel on the forward inboard portion of the wheel well and reaching through to the fuel line coupling.

CAUTION

To prevent damage or contamination of fuel, hydraulic and miscellaneous lines, place a protective cover over the line fittings and ends.

- m. Remove the clamps that are necessary to release the electrical harness assembly. Disconnect the leads from the terminal strip by removing the cover and appropriate nuts and washers.
- n. With the appropriate trim panel removed, disconnect the hydraulic brake line at the fitting located within the cockpit at the leading edge of the wing.
- o. Disconnect the landing gear hydraulic lines at the fittings aft of the spar and within the fuselage.
- p. If the left wing is being removed, it will be necessary to disconnect pitot and static tubes at the elbows located within the cockpit at the wing butt line.

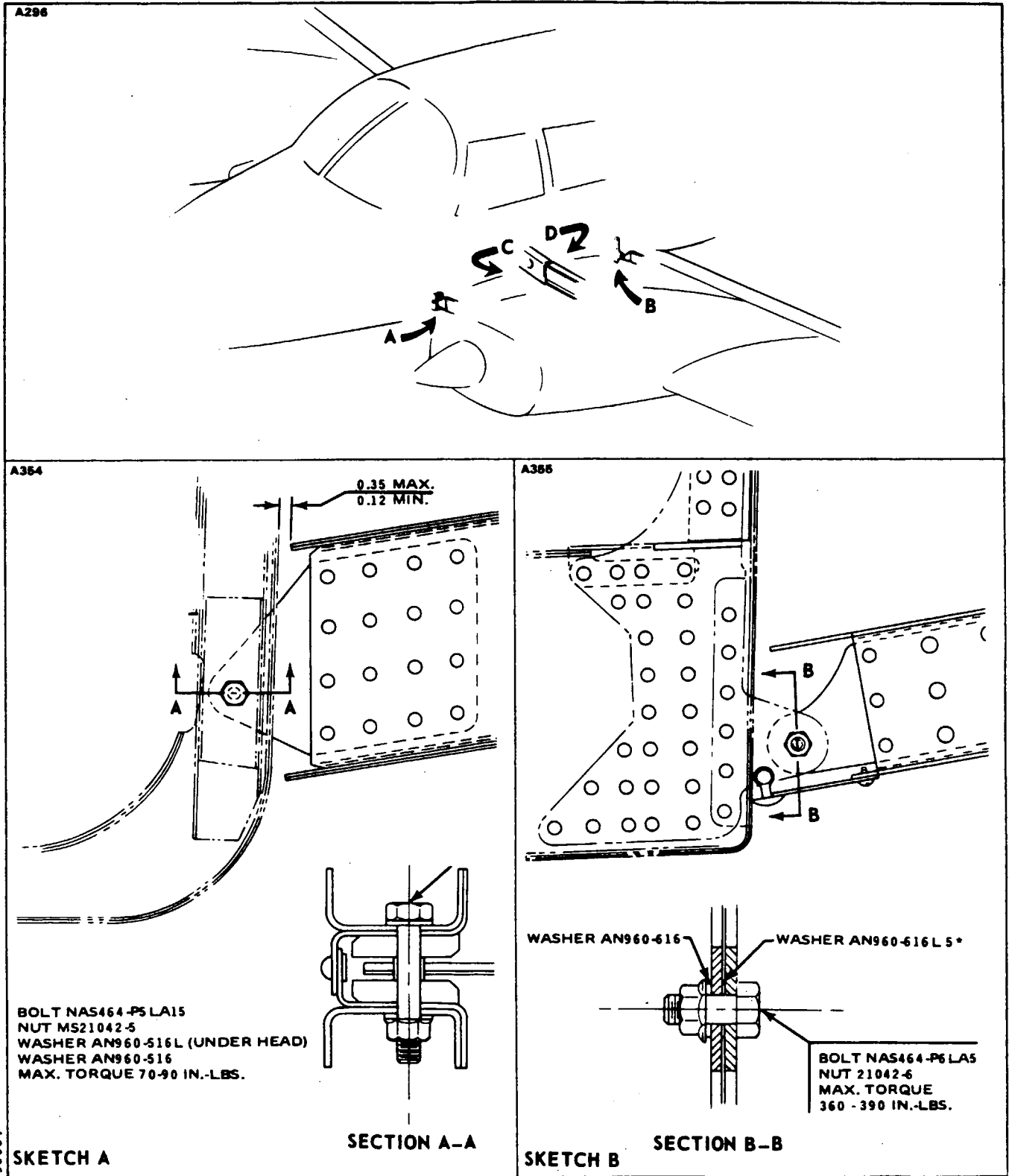

Figure 4-2. Wing Installation

PIPER SENECA II SERVICE MANUAL

BOLT LEGEND 2*

<u>POSITION</u>	<u>BOLT</u>	<u>NUT</u>	<u>WASHER UNDER HEAD</u>	<u>WASHER UNDER NUT</u>
A-1	NAS464 P6 LA17	MS21042-6	(1) AN960-616	(1) AN960-616 (2 MAX.)
A-2	NAS464 P6 LA16	MS21042-6	(1) AN960-616	(1) AN960-616 (2 MAX.)
A-3	NAS464 P6 LA16	MS21042-6	(1) AN960-616	(1) AN960-616 (2 MAX.)
A-4	NAS464 P6 LA16	MS21042-6	(1) AN960-616	(1) AN960-616 (2 MAX.)
A-5	NAS464 P6 LA16	MS21042-6	(1) AN960-616	(1) AN960-616 (2 MAX.)
B-1 4*	NAS464 P6 LA15	H19300-6	(1) AN960-616L	(1) K19301-6 3*
B-2 4*	NAS464 P6 LA14	H19300-6	(1) AN960-616	(1) K19301-6 3*
B-3 4*	NAS464 P6 LA14	H19300-6	(1) AN960-616	(1) K19301-6 3*
B-4 4*	NAS464 P6 LA14	H19300-6	(1) AN960-616	(1) K19301-6 3*
B-5 4*	NAS464 P6 LA14	H19300-6	(1) AN960-616	(1) K19301-6 3*
C-1	NAS464 P5 LA20	MS21042-6	(1) AN960-616L	(1) AN960-616 (2 MAX.)
C-2	NAS464 P6 LA20	MS21042-6	(1) AN960-616L	(1) AN960-616 (2 MAX.)
C-3	NAS464 P6 LA20	MS21042-6	(1) AN960-616L	(1) AN960-616 (2 MAX.)
C-4	NAS464 P6 LA20	MS21042-6	(1) AN960-616L	(1) AN960-616 (2 MAX.)
C-5	NAS464 P6 LA21	MS21042-6	(1) AN960-616L	(1) 96352-3 3*
C-6	NAS464 P5 LA21	MS21042-6	(1) AN960-616L	(1) 96352-2 3*
D-1	NAS464 P5 LA20	MS21042-6	(1) AN960-616L	(1) AN960-616 (2 MAX.)
D-2	NAS464 P6 LA20	MS21042-6	(1) AN960-616L	(1) AN960-616 (2 MAX.)
D-3	NAS464 P6 LA20	MS21042-6	(1) AN960-616L	(1) AN960-616 (2 MAX.)
D-4	NAS464 P6 LA20	MS21042-6	(1) AN960-616L	(1) AN960-616 (2 MAX.)
D-5	NAS464 P6 LA21	MS21042-6	(1) AN960-616L	(1) 96352-3 3*
D-6	NAS464 P5 LA21	MS21042-6	(1) AN960-616L	(1) 96352-2 3*

NOTES

- 2.* TORQUE BOLT HEAD ON UPPER SPAR CAP & NUT ON LOWER SPAR CAP AS FOLLOWS:
 FOR A 5/16 BOLT - 205 - 225 IN.-LBS.
 FOR A 3/8 BOLT - 360 - 390 IN.-LBS.
- 3.* A MAXIMUM OF ONE (1) AN960-616 WASHERS OR AN960-616 WASHER MAY ALSO BE LISTED UNDER THE SPECIAL WASHER.
- 4.* NUTS H19300-6 (B-1, B-2, B-3, B-4 & B-5) TO BE COLOR CODED WITH BLUE PAINT.
- 5.* IT IS ACCEPTABLE TO HAVE THE FACES OF THE FITTING AGAINST EACH OTHER IN WHICH CASE AN960-616L WASHER SHOULD BE USED UNDER THE BOLT HEAD.

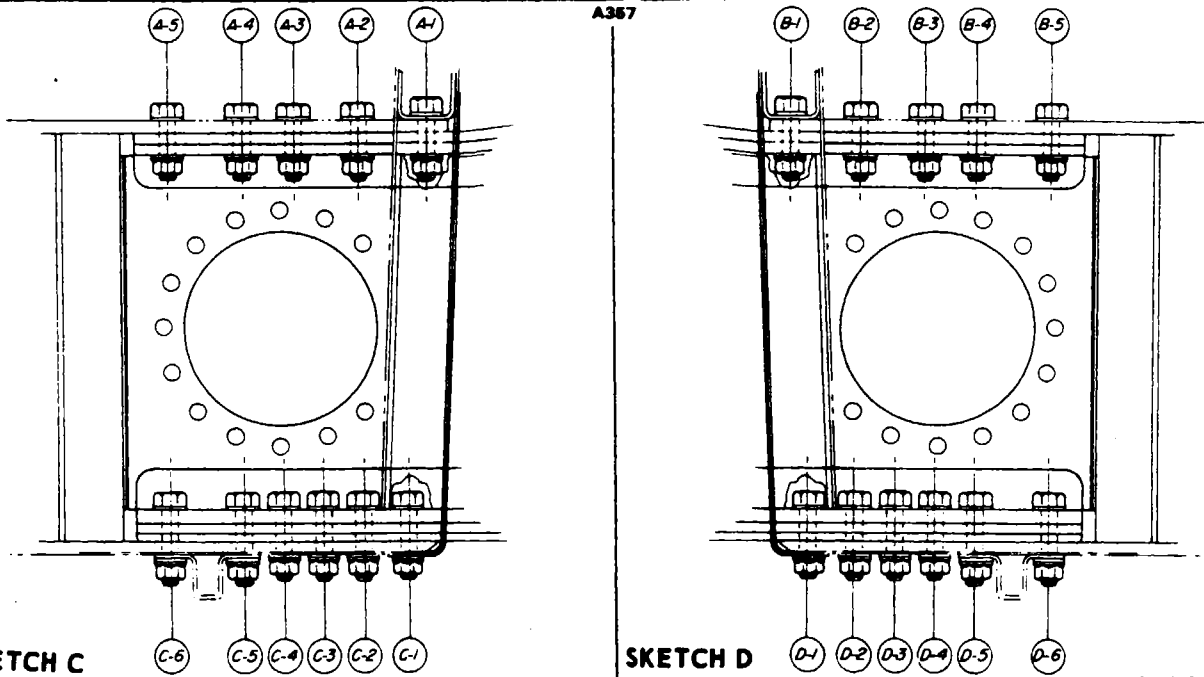

Figure 4-2. Wing Installation (cont.)

- q. Arrange a suitable fuselage cradle and supports for both wings.
- r. Remove the wing jacks.
- s. Remove the front and rear spar nuts, washers and bolts.
- t. Remove the eighteen main spar bolts.
- u. Slowly remove the wing being certain that all electrical leads, control cables, power plant controls, and fuel lines are disconnected.

4-16. INSTALLATION OF WING. (Refer to Figure 4-2.)

- a. Ascertain that the fuselage is positioned solidly on a support cradle.
- b. Place the wing in position for installation, with the spar end a few inches from the side of the fuselage and set on trestles.
- c. Prepare the various electrical leads, fuel lines, control cables, and power plant controls for insertion into the wing or fuselage when the wing is eased into place.
- d. Slide the wing into position on the fuselage.
- e. Install the main spar bolts in accordance with the information given in Figure 4-2, Sketches C and D.
- f. Install the bolt, washers, and nut that attaches the front spar and fuselage fitting. A minimum of one washer is required under the bolt head; then add washers as needed to leave a maximum of one and one-half threads visible or a minimum of bolt chamfer exposed. (Refer to Sketch A, Section A-A of Figure 4-2.)
- g. Install the bolt, washers, and nut that attaches the rear spar and fuselage fitting. It is acceptable to have the faces of the fittings against each other in which case the AN960-616L washer should be used under the bolt head. The AN960-616 washer may be added under the nut when not used as a shim. (Refer to Sketch B, Section B-B of Figure 4-2.) Check to insure that no threads are bearing on the forward plate prior to installing the nut.
- h. Torque the main spar bolts in accordance with specifications given in the bolt legend of Figure 4-2. The forward spar attachment bolt should be torqued to a maximum of 70 to 90 inch-pounds. The rear spar attachment bolt should be torqued to a maximum of 360 to 390 inch-pounds.
- i. Install the wing jacks and tail support to the tail skid with approximately 600 pounds of ballast on the base of the tail support. Remove the fuselage cradle and wing supports.
- j. If the left wing was removed, it is necessary that the pitot and static tubes be connected at the elbows located within the cockpit at the wing butt line. Replace or install clamps where found necessary.
- k. Connect the hydraulic brake line onto the fitting located within the cockpit at the leading edge of the wing and the landing gear hydraulic lines at the fittings within the fuselage aft of the spar.
- l. Connect the leads to the appropriate posts on the terminal strip and install the washers and nuts. (For assistance in connecting the electrical leads, refer to the electrical schematics in Section XI.) Place the clamps along the electrical harness to secure it in position and install the terminal strip dust cover.
- m. Connect the fuel line at the fitting located inside the wing, by reaching through the access panel on the forward inboard portion of the wheel well.
- n. Connect the aileron balance and control cables at the turnbuckles that are located within the fuselage aft of the spar. After the left balance cable has been inserted through the bracket assembly and connected, install a cotter pin cable guard into the hole that is provided in the bracket assembly.
- o. Connect the flap by placing the flap handle in the full flap position; place the bushing on the outside of the rod end bearing and insert and tighten bolt.
- p. Install the engine. (Refer to Installation of Engine, Section VIII.)
- q. Check the rigging and control cable tension of the ailerons and flaps. (Refer to Rigging and Adjustment of Ailerons, and Rigging and Adjustment of Flaps, Section V.)
- r. Service and refill the brake system with hydraulic fluid in accordance with Servicing Brake System, Section II. Bleed the system as outlined in Section VII and check for fluid leaks.

s. Check the fluid level of the landing gear hydraulic system and fill in accordance with Servicing Hydraulic Pump/Reservoir, Section II. With the airplane sitting on jacks, operate the gear through several retraction and extension cycles to be certain that there are no hydraulic leaks. Bleed the hydraulic system in accordance with Section VI. Ascertain that the landing gear is down and locked.

t. Service and fill the fuel system in accordance with Servicing Fuel System, Section II. Open the fuel valve and check for leaks and fuel flow.

u. Check the operation of all electrical equipment, pitot and static systems.

v. Remove the airplane from jacks.

w. Install the cockpit trim panel assembly, spar box carpet, the front and back seats and wing root rubber. Replace all the access plates and panels.

4-17. EMPENNAGE GROUP.

NOTE

Before entering the aft portion of the fuselage, attach a stand to the tail skid for support, and with the use of a heavy pad, protect the inside of the fuselage. Be certain to distribute weight on top of the bulkheads so as not to damage the fuselage skin or bulkhead.

4-18. STABILATOR.

4-19. REMOVAL OF STABILATOR. (Refer to Figure 4-3.)

NOTE

Should it be necessary to move the rudder to its extreme left or right for clearance, do so with the use of the rudder pedals or tow bar.

a. Remove the screws from around the upper and lower tail cone fairing assembly and remove the fairing separately.

b. Block the trim cable at the barrel of the trim screw assembly to prevent the cable from unwrapping.

c. Remove the access panel to the aft section of the fuselage located at the back wall of the baggage compartment.

d. Install cable blocks, as illustrated in Figure 4-4, on the stabilator trim control cable at the first set of pulleys forward of the cable turnbuckles to prevent the forward cable from unwrapping.

e. Disconnect the trim cables at the turnbuckles within the aft section of the fuselage.

f. Relieve tension from the stabilator control cables by loosening one of the cable turnbuckles in the aft section of the fuselage.

g. Disconnect the stabilator control cables from the stabilator balance arm by removing cotter pins, nuts, washers, bushings and clevis bolts.

h. Disconnect the trim assembly from the aft bulkhead of the fuselage by removing the attaching nuts, washers, and bolts of the horizontal and diagonal support brackets.

i. Move the trim assembly up through the tail cone fairing cutout in the stabilator and remove, with cable, from the airplane.

j. Remove the stabilator by disconnecting the stabilator at its hinge points by removing attaching nuts, washers and bolts.

4-20. INSTALLATION OF STABILATOR. (Refer to Figure 4-3.)

NOTE

A clearance of $.25 \pm .06$ of an inch between the stabilator and the side of the fuselage and $.18$ of an inch minimum between all parts of the stabilator and the tail cone assembly must be maintained throughout the stabilator travel. Use a proper washer combination on the stabilator hinges to attain the necessary tolerances.

- a. Insert the stabilator in position and install attaching hinge bolts, washers and nuts.
- b. Move the trim assembly through the cutout in the stabilator and attach the brackets of the assembly to the aft bulkhead with bolts, washers and nuts. Insert the trim cable ends into the fuselage.
- c. Attach the stabilator control cables to the stabilator balance arm with clevis bolts, bushings, washers, nuts and cotter pins.
- d. Connect the ends of the fore and aft trim cables at the turnbuckles within the aft section of the fuselage.
- e. Remove the cable block from the trim control cable within the fuselage.
- f. Set stabilator control cable tension and check rigging and adjustment according to Rigging and Adjustment of Stabilator, Section V.
- g. Remove the cable blocks from the trim cable at the barrel of the trim screw assembly.
- h. Set stabilator trim control cable tension and check rigging and adjustment according to Rigging and Adjustment of Stabilator Trim, Section V.
- i. Remove the pad from the aft section of the fuselage and replace the access panel.
- j. Install the tail cone fairing and remove tail stand.

NOTE

When stabilator and/or stabilator trim tab is replaced, the balance may be disturbed. Rebalancing is required.

4-21. STABILATOR TRIM TAB.

4-22. REMOVAL OF STABILATOR TRIM TAB. (Refer to Figure 4-3.)

- a. Disconnect the stabilator trim control rod by removing the bolts that attach the control rod to the stabilator trim tab.
- b. Remove the stabilator trim hinge pins by cutting one end of the wire pins and removing.
- c. The stabilator trim tab can now be removed.

4-23. INSTALLATION OF STABILATOR TRIM TAB. (Refer to Figure 4-3.)

- a. Place the trim tab in position on the aft end of the stabilator.
- b. Replace the old hinge pins with new pins. (Refer to Parts Catalog for proper Part No.)
- c. Insert the pins and secure by bending the end to a 45 degree angle.
- d. Install the control rod and attach with the four bolts and washers.
- e. The trim tab free end play must not exceed $.125$ inches maximum.

1E6
INTENTIONALLY LEFT BLANK

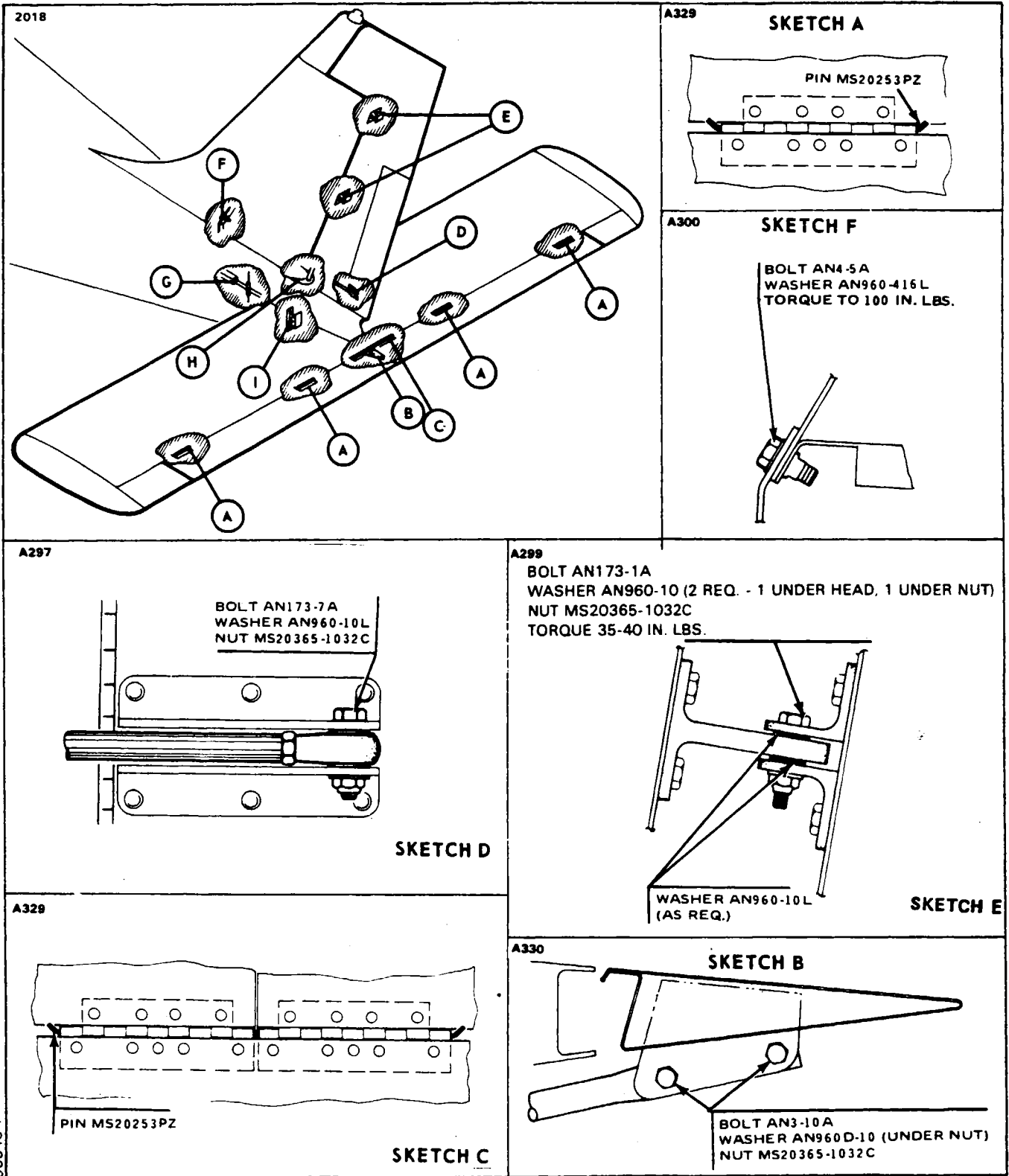

Figure 4-3. Empennage Group

Revised: 11/12/82

1E7

STRUCTURES

PIPER SENECA II SERVICE MANUAL

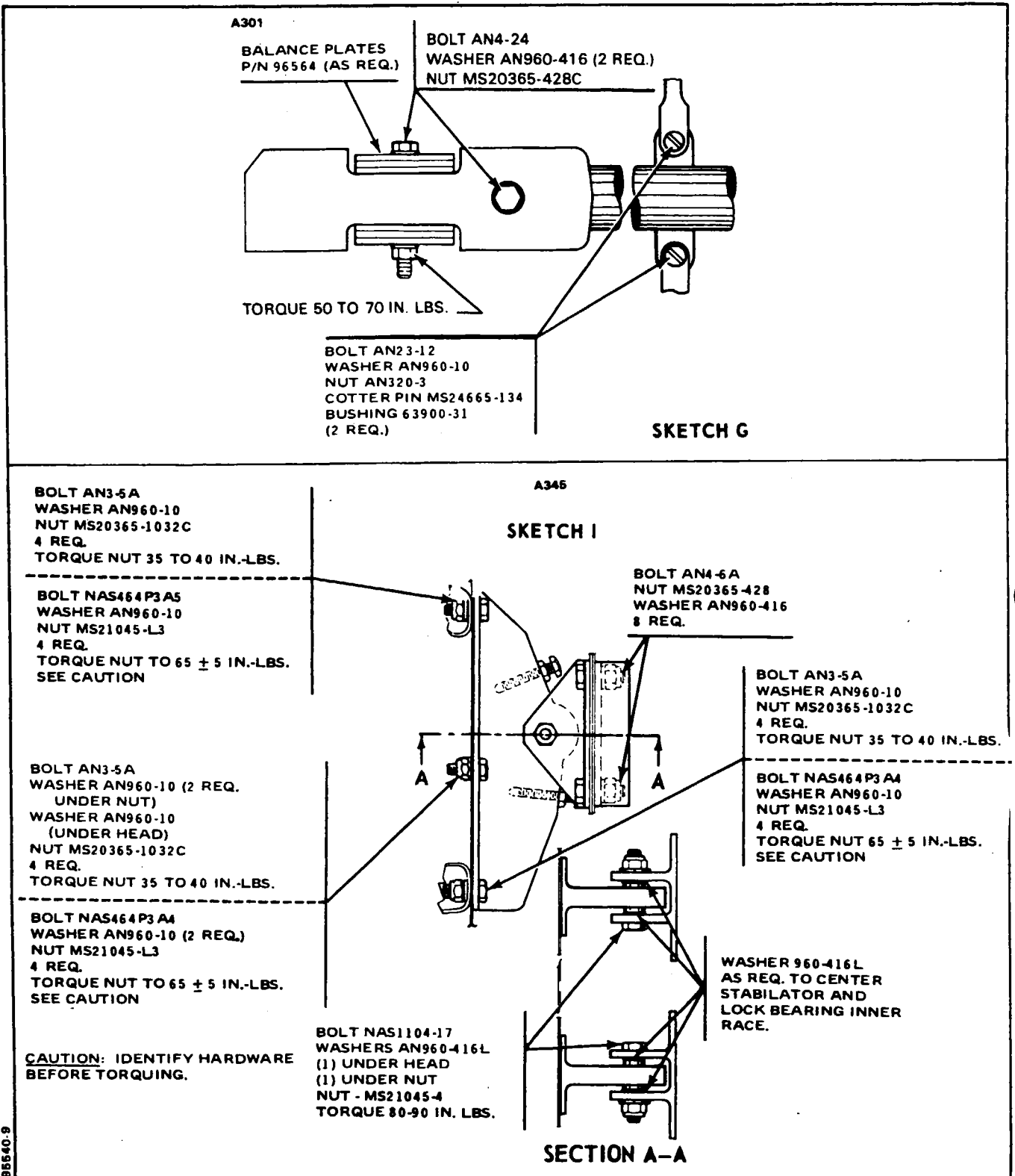
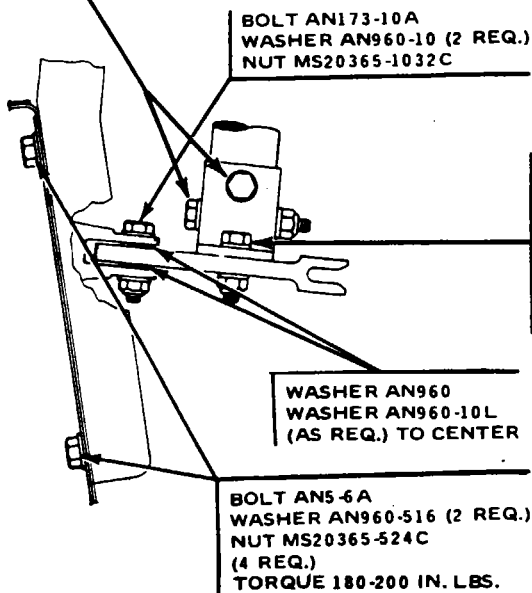

Figure 4-3. Empennage Group (cont.)

PIPER SENECA II SERVICE MANUAL

SKETCH H

BOLT AN173-16A TORQUE 38-43 IN.-LBS.
NUT MS20365-1032C
OR
*BOLT AN174-16A TORQUE 70-80 IN.-LBS.
*NUT MS20365-428C
WASHER AN960-PD10
WASHER AN960-PD416L (UNDER HEAD)
WASHER AN960-PD 416 (UNDER NUT)



*IF KIT 764 100V HAS BEEN INCORPORATED

Figure 4-3. Empennage Group (cont.)

Revised: 12/08/83

1E9

STRUCTURES

4-24. RUDDER.

4-25. REMOVAL OF RUDDER. (Refer to Figure 4-3.)

- a. Remove the screws from around the upper tail cone fairing assembly and remove the fairing.
- b. Remove the rudder tip by removing the attaching screws and disconnect the tail position light wire at the quick disconnect located at the tip of the rudder. Open the access panel in the rear of the baggage compartment to gain access to the aft section of the fuselage.
- c. Relieve the cable tension from the rudder control system by loosening one of the cable turnbuckles in the aft section of the fuselage.
- d. Disconnect the two control cables from the rudder horn by removing the cotter pins, nuts, washers, bushings and bolts.
- e. Disconnect the rudder trim tab push rod from the actuating link by removing cotter pin, nut, washer and bolt.
- f. Disconnect the jumper lead between the rudder and vertical fin.
- g. Remove the cotter pins, nuts, washers, and bolts from the upper and lower rudder hinge pivot points.
- h. Pull the rudder up and aft from the vertical fin.

4-26. INSTALLATION OF RUDDER. (Refer to Figure 4-3.)

- a. Place the rudder in position and install the hinge bolts, washers, nuts and cotter pins.

NOTE

Use any washer combination of the hinge assembly to suit best, the centering and operation of the rudder.

- b. Connect the rudder trim tab push rod to the actuating link with bolt, washer, nut and cotter pin.
- c. Connect the tail position light electrical lead at the quick disconnect and cover the connector with an insulating sleeve. Tie both ends of the sleeve with number six electrical lacing twine.
- d. Connect the jumper lead between the rudder and vertical fin.
- e. Connect the control cables to the rudder horn with bolts, washers, nuts and cotter pins.
- f. Check the rudder in accordance with Rigging and Adjustment of Rudder, Section V.
- g. Install the upper tail cone fairing and rudder tip and secure with the attachment screws. Secure the access panel to the aft section of fuselage.

NOTE

When rudder and/or rudder trim tab is replaced, the balance may be disturbed. Rebalancing is required.

4-27. RUDDER TRIM TAB.

4-28. REMOVAL OF RUDDER TRIM TAB. (Refer to Figure 4-3.)

- a. Remove the bolt assembly which connects the trim tab actuating arm to the tab assembly.
- b. Remove the trim tab hinge pin and remove the tab assembly from the rudder.

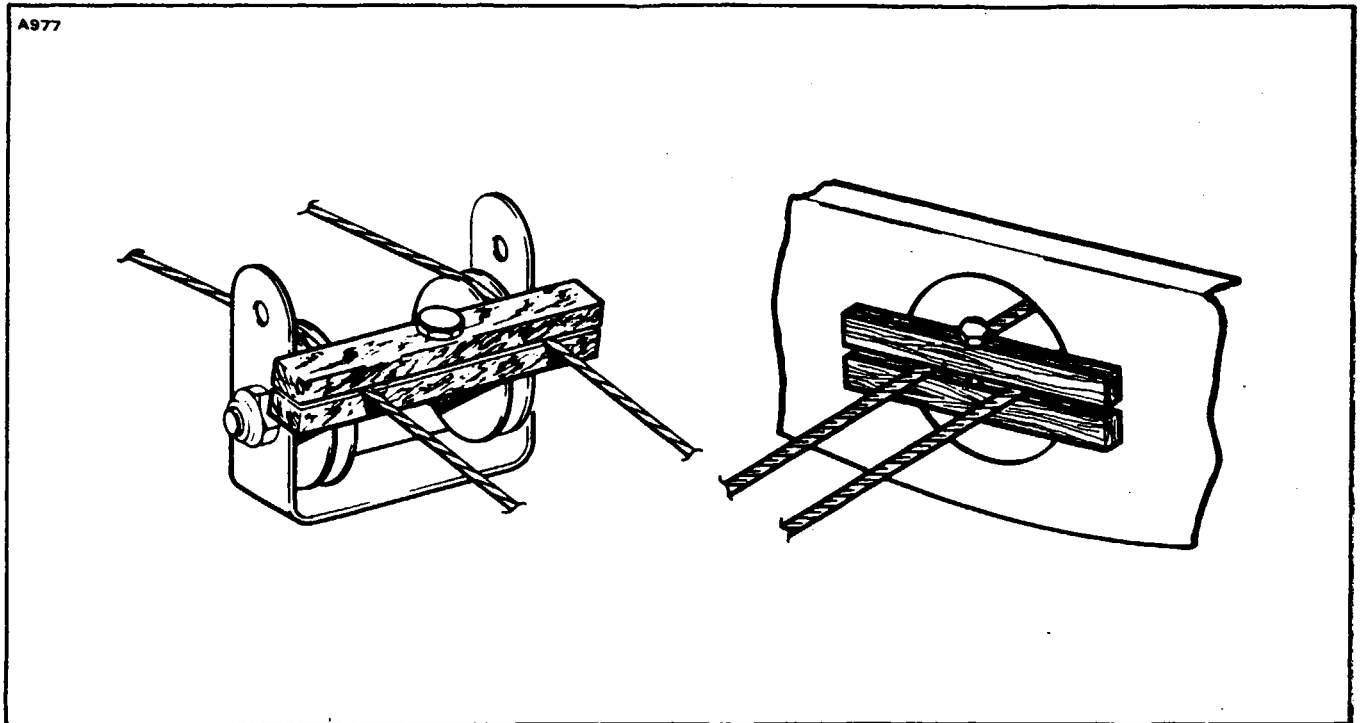

Figure 4-4. Methods of Securing Control Cables

4-29. INSTALLATION OF RUDDER TRIM TAB. (Refer to Figure 4-3.)

- a. Position the trim tab assembly into the rudder aligning the two hinge bolts.
- b. Install a new hinge pin. Ascertain that at least .50 of an inch of hinge pin extends out from each end of the hinge.
- c. Bend both ends of the hinge pin to a 30° angle to secure it in place.
- d. Connect the trim tab actuating arm to the bracket and the tab and secure with bolt assembly.

4-30. VERTICAL FIN.

4-31. REMOVAL OF VERTICAL FIN. (Refer to Figure 4-3.)

- a. Remove the screws from the upper and lower tail cone fairing; the fin tip cover and the fairing at the forward base of the fin.
- b. Remove the rudder per instructions given in Paragraph 4-25.
- c. Disconnect the leads from the antenna terminals (optional) and attach a line to the leads to assist in reinstallation.
- d. Disconnect the wire antenna (optional) that attaches to the leading edge of the fin.
- e. Disconnect the positive lead to the rotating beacon (optional) and attach a line prior to removal. Disconnect the ground lead by removing the attachment screw.
- f. Remove the rudder trim assembly and trim cable in accordance with Removal of Rudder Trim Assembly, Section V.
- g. Remove the bolt and washer that attaches the leading edge of the fin to the fuselage.
- h. Remove the nuts, washers, and bolts that secure the fin spar to the aft bulkhead and remove the vertical fin.

4-32. INSTALLATION OF VERTICAL FIN. (Refer to Figure 4-3.)

- a. Insert the vertical fin into position and install the bolts, washers, and nuts that secure the fin spar to the aft bulkhead.
- b. Install the bolt and washer that attaches the leading edge of the fin to the fuselage.
- c. Install the rudder trim assembly and trim cable per instructions given in Installation of Rudder Trim Assembly, Section V.
- d. Install the rudder per Paragraph 4-26.
- e. Pull the electrical and antenna leads through the vertical fin with the line that was attached.
- f. Connect the antenna leads to the proper terminals and secure with the washers and nuts.
- g. Connect the electrical leads at the disconnects and insulate.
- h. Rig and adjust the rudder and trim control cables as given in Section V.
- i. Check the operation of the radios and electrical lights.
- j. Replace all fairings and access plates and secure with attaching screws.

4-33. FUSELAGE ASSEMBLY.

4-34. WINDSHIELD.

4-35. REMOVAL OF WINDSHIELD. (Refer to Figure 4-5.)

- a. Remove the collar molding from around the bottom of the windshield by removing attaching screws.
- b. Remove the trim strip from between the windshield halves by removing attaching screws.
- c. Remove the windshield by raising the lower portion of the windshield and pulling forward.
- d. Clean old tape and sealer from the windshield retainer channels and strips.

4-36. INSTALLATION OF WINDSHIELD. (Refer to Figure 4-5.)

- a. Ascertain that the new windshield outside contours are that of the old windshield. It may be necessary to cut or grind the new windshield.
- b. Apply black vinyl plastic tape around the outer edge of the entire windshield.
- c. Apply a strip of vinyl foam tape (1/8 x 1" wide - type 1 P.V.C.) over the plastic tape completely around the top and outboard edges of the windshield.
- d. Apply white PRC # 5000 sealing compound (Product Research Corporation) in the upper and outboard windshield channel.
- e. Slide the windshield aft and up into place. Use caution not to dislocate the tape around the edges of the windshield. Allow clearance between the two sections of the windshield, at the divider post, for expansion.
- f. Lay sealant at the bottom and center (inboard) of the windshield, in the hollow between the outside edge and channel.
- g. Lay a small amount of sealant under the center trim strip; install and secure.
- h. Lay black vinyl tape on the underside of the collar molding; install and secure.
- i. Apply sealant to any areas around windshield that may allow water to penetrate past windshield.
- j. Remove excess exposed sealer or tape.

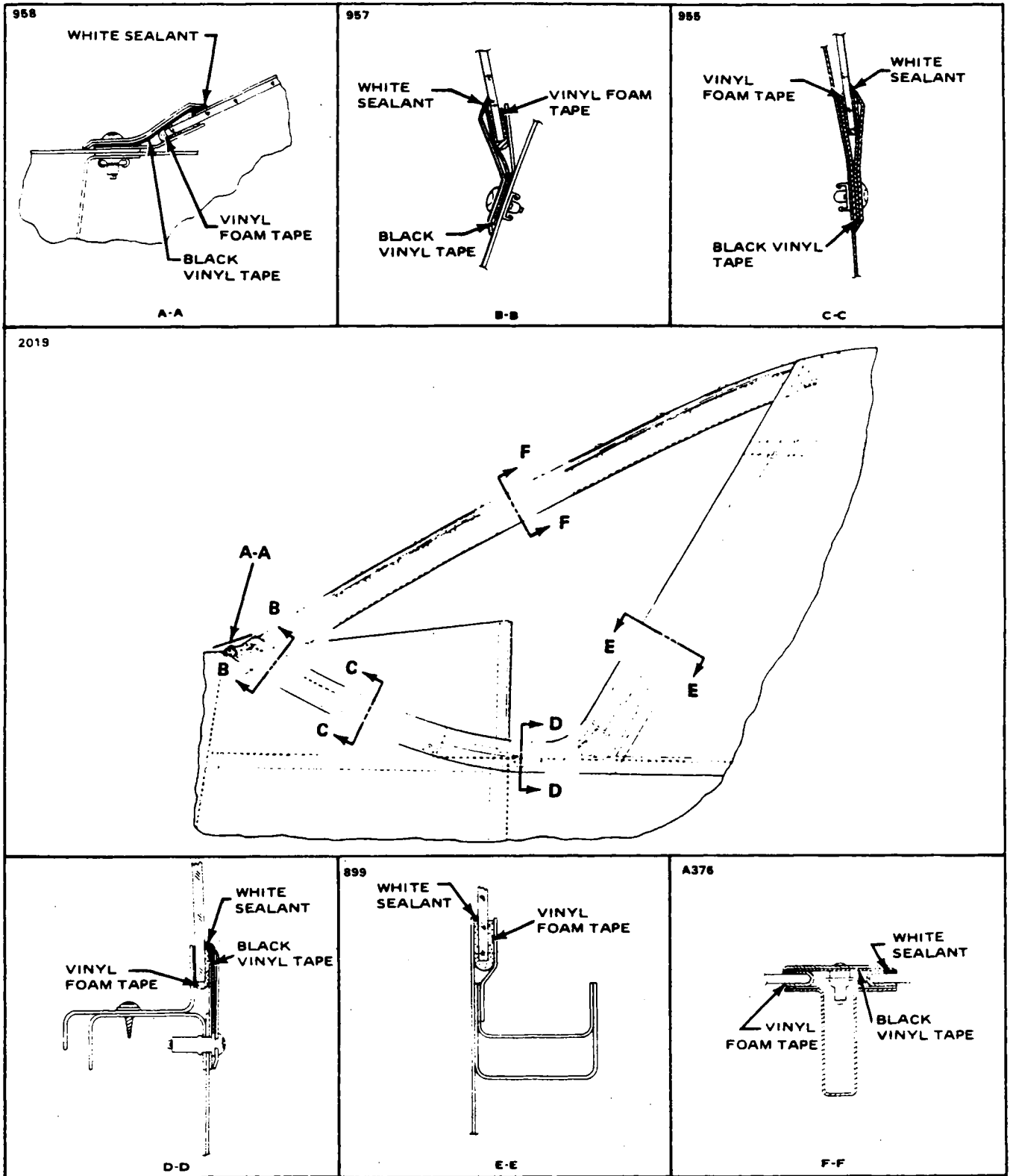

Figure 4-5. Windshield Installation

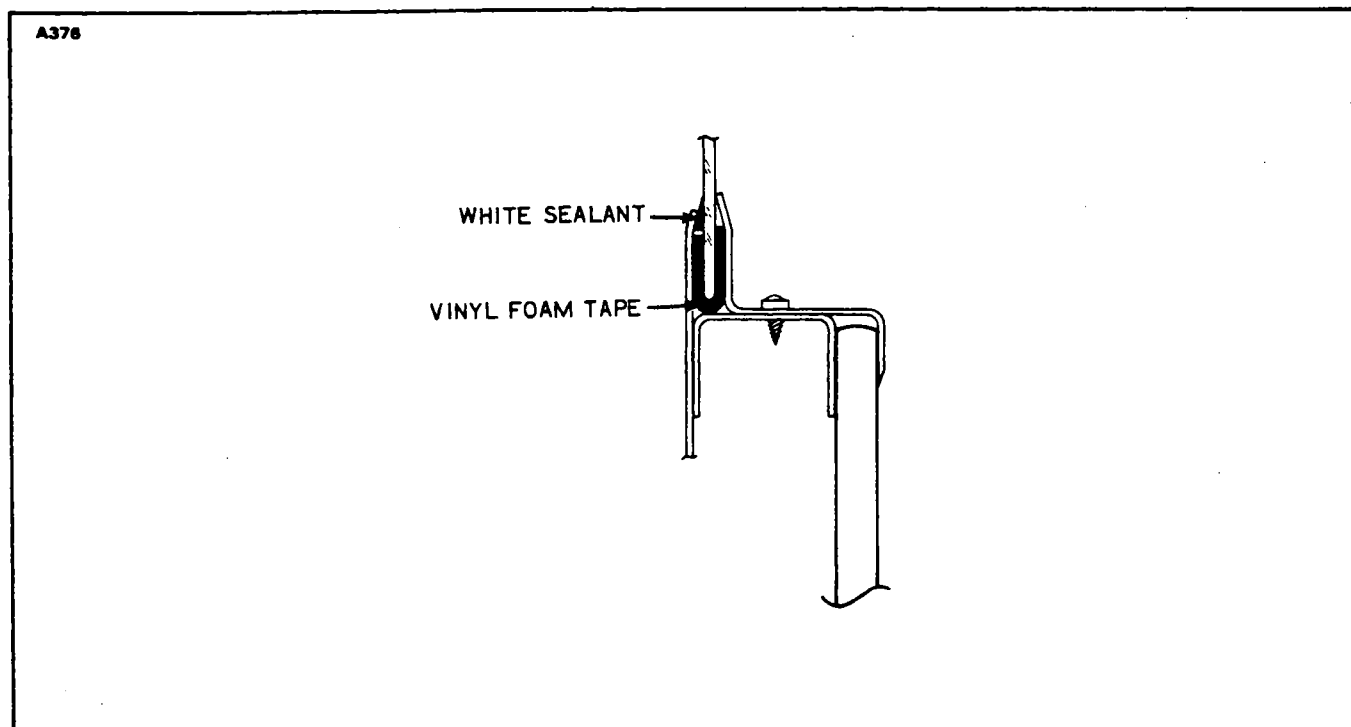

Figure 4-6. Side Window Installation (Typical)

4-37. SIDE WINDOWS.

4-38. REMOVAL OF WINDOWS (SIDE). (Refer to Figure 4-6.)

- a. Remove the retainer molding from around the window by removing attachment screws. At the forward end of both the right and left window that is adjacent to the second row of seats, the window retainer is riveted in place and need not be removed.
- b. Remove the window from the frame.
- c. Remove excess tape and sealer from the window frame.

NOTE

A damaged window should be saved to provide a pattern for shaping the new window.

4-39. INSTALLATION OF WINDOWS (SIDE). (Refer to Figure 4-6.)

- a. Cut or grind the new window to the same dimension as the window removed.
- b. Apply a strip of vinyl foam tape (1/8 x 1" wide - Type I P.V.C.) completely around the edge of the window.
- c. Apply white PRC 5000 sealing compound (Product Research Corporation) completely around the outer surface of the window at all attachment flanges.
- d. Install the window in the frame and install retainer moldings. Secure with screws.
- e. Remove excess exposed sealer and tape.

4-40. REMOVAL OF REAR DOOR WINDOW. (Refer to Figure 4-7.)

- a. Although it is not necessary, the door may be taken off the airplane. If the door is removed, make sure it is placed on a surface that will not scratch the painted finish of the door.
- b. Remove the trim panels on the door.
- c. Unscrew the window retainers and carefully remove the window. Remove any excess tape and sealer from the window frame as well.

NOTE

A damaged window should be saved to provide a pattern for fitting the new window.

4-41. INSTALLATION OF REAR DOOR WINDOW. (Refer to Figure 4-7.)

- a. With the windows compared to each other, grind the new window to the same outlying dimensions as the old.
- b. With the frame thoroughly cleaned align the new window in the frame to insure a proper fit.
- c. Remove the new window and proceed as follows:
 1. Apply 3/4 inch wide sealant tape to the contacting exterior surfaces of the window (around the perimeter of the window that touches the door's skin).
 2. With the tape aligned on the window, apply pressure to force the seal against the window.
 3. Remove the protective paper from the tape and set window in place on the door.
 4. With a narrow, hand held, rubber roller, apply pressure around the perimeter of the window to cause a tight seal between the window and skin.
- d. Reinstall window retainer clips and trim panels.

THIS SPACE INTENTIONALLY LEFT BLANK

PIPER SENECA II SERVICE MANUAL

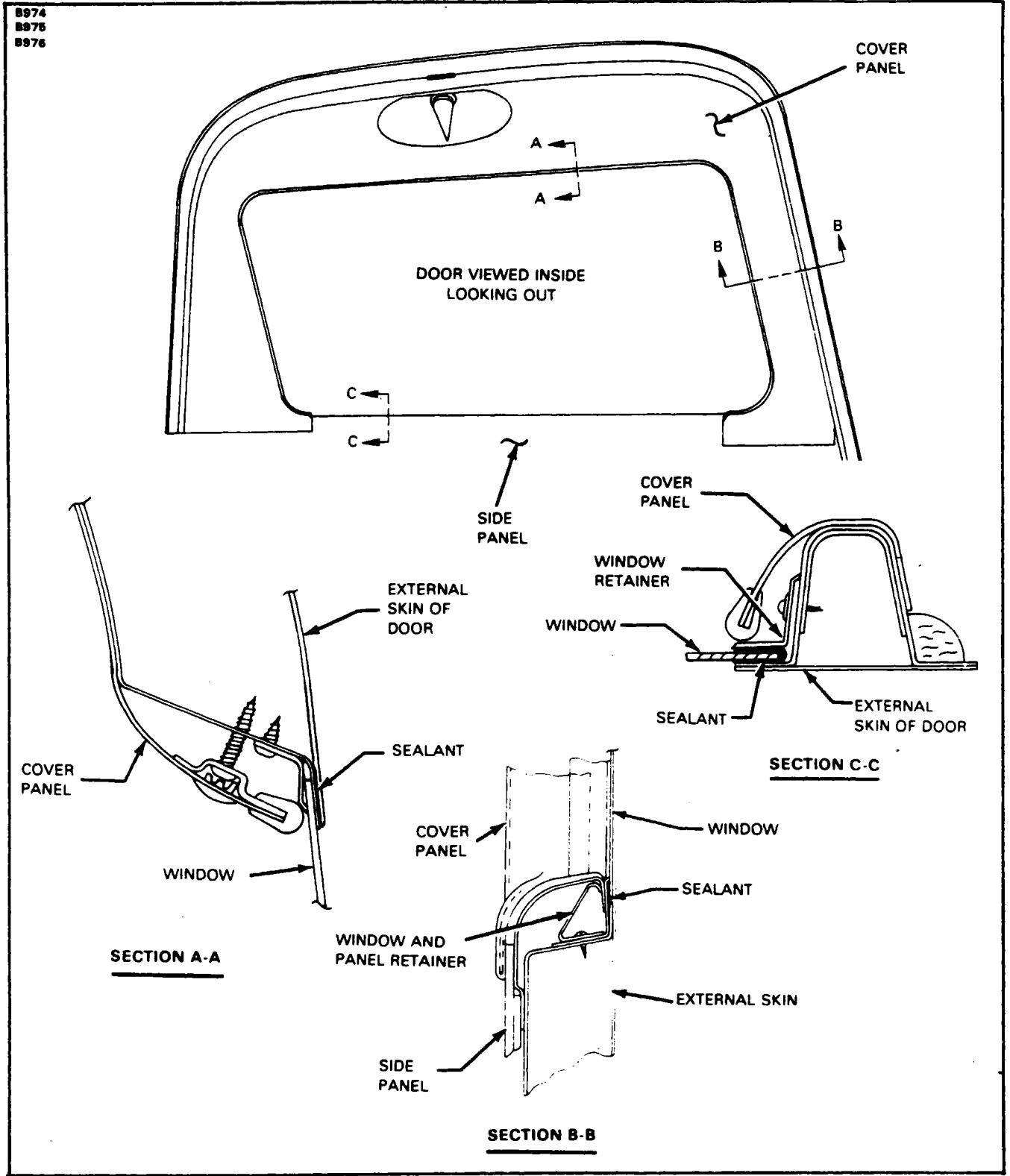

Figure 4-7. Rear Door Window Replacement

- g. Place new retainer into position and secure with 16 screws and washers (AN960-6).
- h. Carefully invert the door. Apply a bead of PRC-5000 sealant to the outer perimeter of the window. Allow sealant to dry before reinstalling door.

NOTE

Inspect to determine that all original bond lines between outer panel and window and window and inner panel are tight. Fresh breaks in bond lines can be sealed using one of the following:

1. Eastman 910
2. Aron Alpha Vigor Tool Co., NYC., N.Y.

Older breaks in bond lines should be sealed using one of the following adhesives:

1. Scotchweld 2216 B/A Liquid Epoxy, MMM Co., St. Paul, Minnesota
2. Chemlock 304 Hughson Chemical Co., Erie, Penna.
3. Reiweld 7006 H.B. Fuller Co., St. Paul, Minnesota
4. Loctite 2508† Loctite Corp., Newington, Conn.
†Packaged in 1 oz. cups for ready mix under P/N 53-83

4-42. DOOR (ENTRANCE).

4-42a. REMOVAL AND INSTALLATION OF DOOR SNUBBERS. Door snubber seals have been incorporated in the three door jambs to improve on door sealing. For those aircraft equipped as such, the following procedure should be used. If snubbers are not installed, the "Field Kit For Improved Sealing" (763-993V). should be consulted for installation if so desired.

NOTE

If the existing seal is torn or badly deteriorated, it should be replaced. If the seal is found to be loose, or the bond is "marginal," it should be rebonded. The adhesives listed herein are recommended for the following procedure.

1. Carboline Adhesive F-1.
2. Scotch Grip 2210.
3. Proco #6205-1.

Refer to the List of Consumable Materials for vendor information.

- a. To remove the snubber proceed as follows:
 1. Back off the windlacing trim screws, tape the windlacing back out of the way, and remove all scuff plates.
 2. With mineral spirits, soak the edges of the snubber all around the door jamb.
 3. With a plastic scraper or other appropriate instrument, scrape off the snubber while applying mineral spirits as necessary to loosen the strip.
 4. With mineral spirits and a clean cloth clean off all excess adhesive.
- b. Before proceeding with installation instructions make sure the windlacing is rolled back far enough to prevent adhesive from coming in contact with it.

PIPER SENECA II SERVICE MANUAL

8852

**FORWARD CABIN
DOOR INSTALLATION**

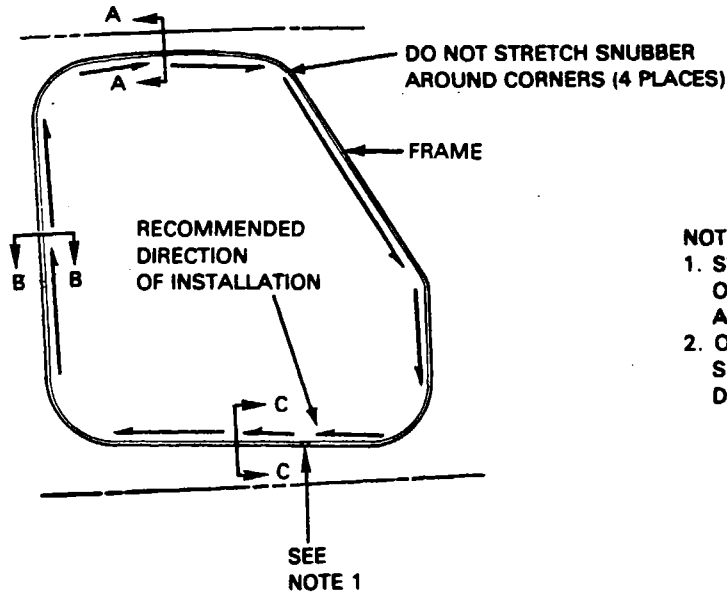

NOTES:

1. SNUBBER BUTT JOINT SHOULD OCCUR AT DOOR DRAIN AREA AS APPLICABLE.
2. ORIENT SNUBBER FLAT WITH SURFACE INDICATED BY NOTE DESIGNATION.

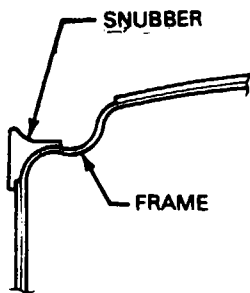

SECTION A-A

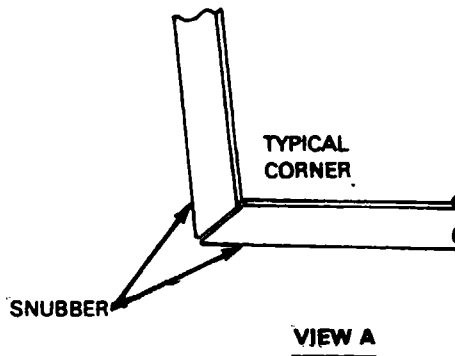

VIEW A

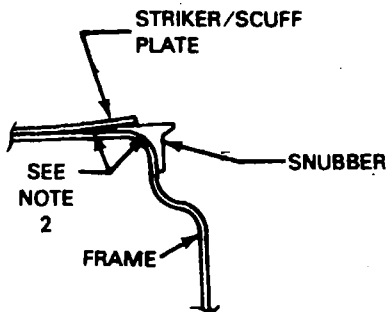

**SECTION B-B
(ROTATED 180°)**

SECTION C-C

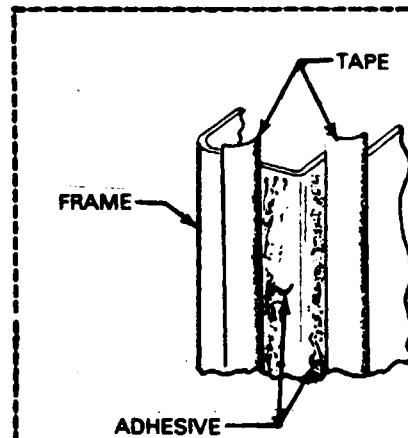

APPLICATION OF ADHESIVE

Figure 4-7a. Snubber Installation

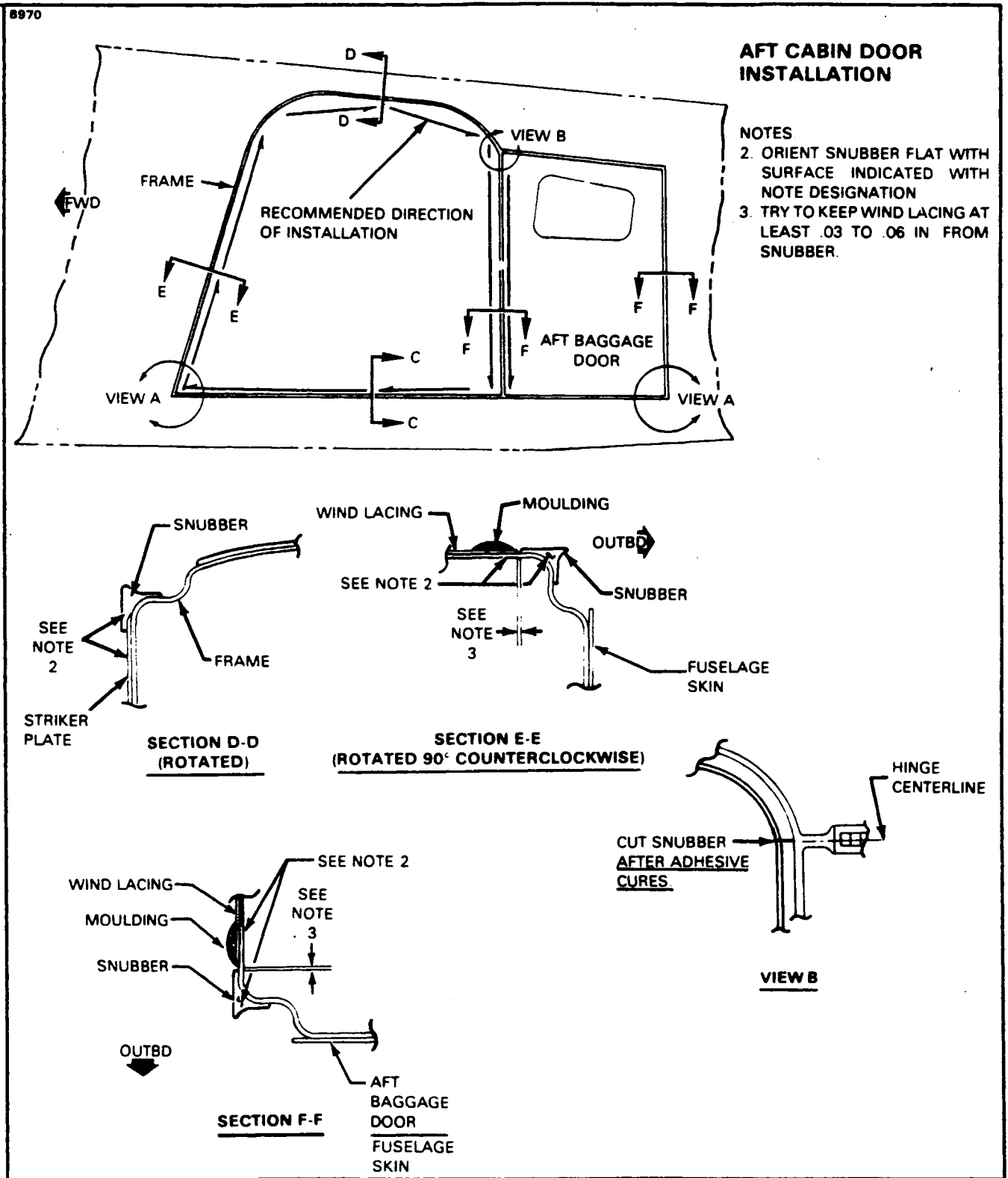

Figure 4-7a. Snubber Installation (cont.)

Added: 8/10/80

1E19

STRUCTURES

PIPER SENECA II SERVICE MANUAL

- c. If the door jamb is flaking or excessively scuffed proceed as follows:
 1. Rub down and feather the finish with "wet or dry" emery cloth. Make sure to go over the surface with fine (400 grit) paper.
 2. Go over the surface with "Prep-Sol" or other type of cleaner that will not leave an oily residue.
 3. Prime, sand (400 grit), and paint affected area. Wait for paint to dry before proceeding.
- d. Go over the entire door jamb with "Prep-Sol" or other cleaner that will not leave an oily residue.
- e. On aircraft up to 34-7670063 cut a length of snubber to fit the installation plus two or three inches to spare. On aircraft 34-7670064 and up use the appropriate snubber installation or as just described if a supply is available.

NOTE

Normal tack time for Carboline F-1 (which is used as a reference) is 30 to 45 minutes, less in a warm area.

NOTE

On forward cabin door make sure leg of snubber goes under striker plate on side latch and over the striker plate for the upper latch.

On the aft cabin and cargo doors make sure the baggage door is closed and start at the forward edge of the cabin door working upward. Make sure leg of snubber is under striker plate.

- f. Although not critical it is recommended that masking tape be applied to the door jamb at the borders of the area to be glued. (Refer to Figure 4-7a.)
- g. Apply adhesive to the affected area on the door jamb and the inside surface of the snubber. It is recommended that the snubber be installed before the adhesive becomes tacky enabling manipulation of the snubber.
- h. Position the snubber with the teat facing outboard and **start at the bottom center** of the jamb, applying pressure to insure a proper bond. **DO NOT** prestretch the snubber. Stretching the snubber will cause cracks.
- i. Wait for at least two hours for the bond to cure and **DO NOT** allow door to close. The bond will cure more efficiently with the door left open and a maximum cure age will be effected.
- j. To check for proper cure try peeling back a small local area of the snubber leg.
- k. With adhesive properly cured, remove the masking tape. Replace scuff plates and windlacing. If the snubber for the aft cabin door has just been installed, cut snubber as shown in Figure 4-7a.
- l. Check that the door closes properly and readjust as necessary to achieve a flush fit. Latching effort must not have increased.
- m. With all hardware and plates reinstalled coat snubbers with silicone.

4-43. REMOVAL OF DOOR.

- a. Remove clevis bolt, washer, and bushing from door holder assembly.
- b. Remove cotter pins, clevis pins, and washers from serrated door hinges.
- c. Remove door from airplane.

4-44. INSTALLATION OF DOOR.

- a. Insert the door into position and install the washers, clevis bolts, and cotter pins on the door hinges.
- b. For adjustment of door, refer to Paragraph 4-45.
- c. Hook up and install the clevis bolt, bushing, and washer into the door holder assembly.

4-45. ADJUSTMENT OF DOOR.

- a. To acquire the proper vertical adjustment of the door, insert the necessary washer combination between the cabin door hinge and fuselage bracket assembly.
- b. Additional adjustments must be made by tapping out the serrated door hinge, bushings and rotating them to obtain the hinge centerline location that will provide proper door fit.

4-46. REMOVAL OF DOOR LATCH MECHANISM.

- a. Remove the door latch mechanism by removing the door trim upholstery and the screws that attach the latch plate and latch mechanism to the door.
- b. Disconnect the latch pull rod from the inside door handle.
- c. Remove the complete latch mechanism.

4-47. INSTALLATION OF DOOR LATCH MECHANISM.

- a. Place the latch assembly into position on the door.
- b. Connect the latch pull rod to the inside door handle.
- c. Replace the screws that attach the latch plate and mechanism to the door. Install the door trim upholstery and secure with screws.

4-48. ADJUSTMENT OF DOOR LATCH MECHANISM. To adjust the door latch, loosen the screws on the striker plate; make necessary adjustment and retighten the screws.

4-49. REMOVAL OF DOOR LOCK ASSEMBLY.

- a. Remove the door trim upholstery by removing the attachment screws.
- b. Loosen the nut on the lock assembly and remove the lock by turning it sideways.

4-50. INSTALLATION OF DOOR LOCK ASSEMBLY.

- a. Install the lock in the door by turning it sideways and placing it through the opening provided.
- b. Replace the nut on the back of the lock assembly and tighten.
- c. Replace the door trim upholstery and secure with the attachment screws.

4-51. REMOVAL OF DOOR SAFETY (AUXILIARY) LATCH.

- a. Remove screw and handle from top outer surface of door.
- b. Remove screws holding latch assembly to the inner panel of the door and remove the latch.

4-52. INSTALLATION OF DOOR SAFETY (AUXILIARY) LATCH.

- a. Insert hook through rectangular slot in top of door. Align holes in latch assembly with those in the door inner panel and secure with screws.
- b. Install outer handle and screw.

4-53. ADJUSTMENT OF DOOR (AUXILIARY) LATCH.

- a. To adjust the door safety latch, remove the two screws from latch plate found at the top of the door opening.
- b. Remove the plate and turn the loop assembly in or out to make necessary adjustments.
- c. Replace the latch plate and secure with the two attachment screws.

4-54. BAGGAGE DOOR.

4-55. REMOVAL OF BAGGAGE DOOR. With the door open, remove the hinge pin from the hinge and remove the door.

4-56. INSTALLATION OF BAGGAGE DOOR: Place the door in position so that the hinge halves are properly matched and install the hinge pin. It will not be necessary to replace the hinge pin with a new pin if it is free of bends and wear.

4-57. REMOVAL OF BAGGAGE DOOR LOCK ASSEMBLY.

- a. With door open, remove the nut from the back of the lock assembly.
- b. Remove the lock assembly through the front of the door.

4-58. INSTALLATION OF BAGGAGE DOOR LOCK ASSEMBLY.

- a. Insert the lock through the hole in the front of the door.
- b. Insert the nut on the lock assembly and tighten.

4-59. REMOVAL OF BAGGAGE DOOR HINGE.

- a. Remove the door from the airplane as described in Removal of Baggage Door, Paragraph 4-55.
- b. Remove the hinge half from the airplane or door by drilling out the rivets and removing the hinge.

4-60. INSTALLATION OF BAGGAGE DOOR HINGE.

- a. Place the hinge halves together and install the hinge pin.
- b. Install the door into the closed position and drill the two end rivet holes and install the rivets.
- c. Operate the door and check for proper fit and installation. Drill the remaining holes and install the rivets.

4-61. RIGGING INSTRUCTIONS - SEAT BACK LOCK AND RELEASE. (Refer to Figure 4-8.)

- a. Loosen screws (1 and 2) and ascertain that clamps (3 and 4) are in a relaxed condition. (Push-pull cable (6) is able to move within the clamps.)
- b. Place a straightedge along the lower surface of bushing (5) of the seat back release.
- c. Adjust the push-pull cable (6) by raising or lowering it until the lower surface of the stop assembly (7) is parallel to the straightedge.
- d. Secure the push-pull cable in this position by tightening screws (1 and 2) on clamps (3 and 4). The stop (7) should be lubricated and free to swivel without excessive play.
- e. Push on seat back with stop assembly (7) in an engaged position to check engagement. Rotate the seat back release handle and check for disengagement of seat back.

4-61a. SHOULDER HARNESS INERTIA REEL ADJUSTMENT.

- a. Allow the harness to wind up on the reel as much as possible.
- b. On the end of the reel, pry off the plastic cap over the spring, making sure the spring does not come out of the plastic cap, and set cap aside.
- c. Unwind the harness completely, then measure and mark the harness 24 inches from the reel center.
- d. Wind the harness onto the reel until the 24 inch mark is reached, then hold reel and place cap with spring over the reel shaft end.
- e. Aligning slot in shaft with spring tang, wind spring 6 turns $\pm 1/2$ turn and snap the plastic cover into holes in reel end shaft.
- f. Release harness and allowing it to wind up, extend the harness a few times to check reel for smooth operation.
- g. With reel fully wound, hold with inertia mechanism end up and pry off plastic cap over mechanism and set reel aside.
- h. Install nut in plastic cap so that stud in cap is flush with nut surface, then reposition cap over reel end and orientating properly, snap in place. Extend harness a few times to make sure action is correct.

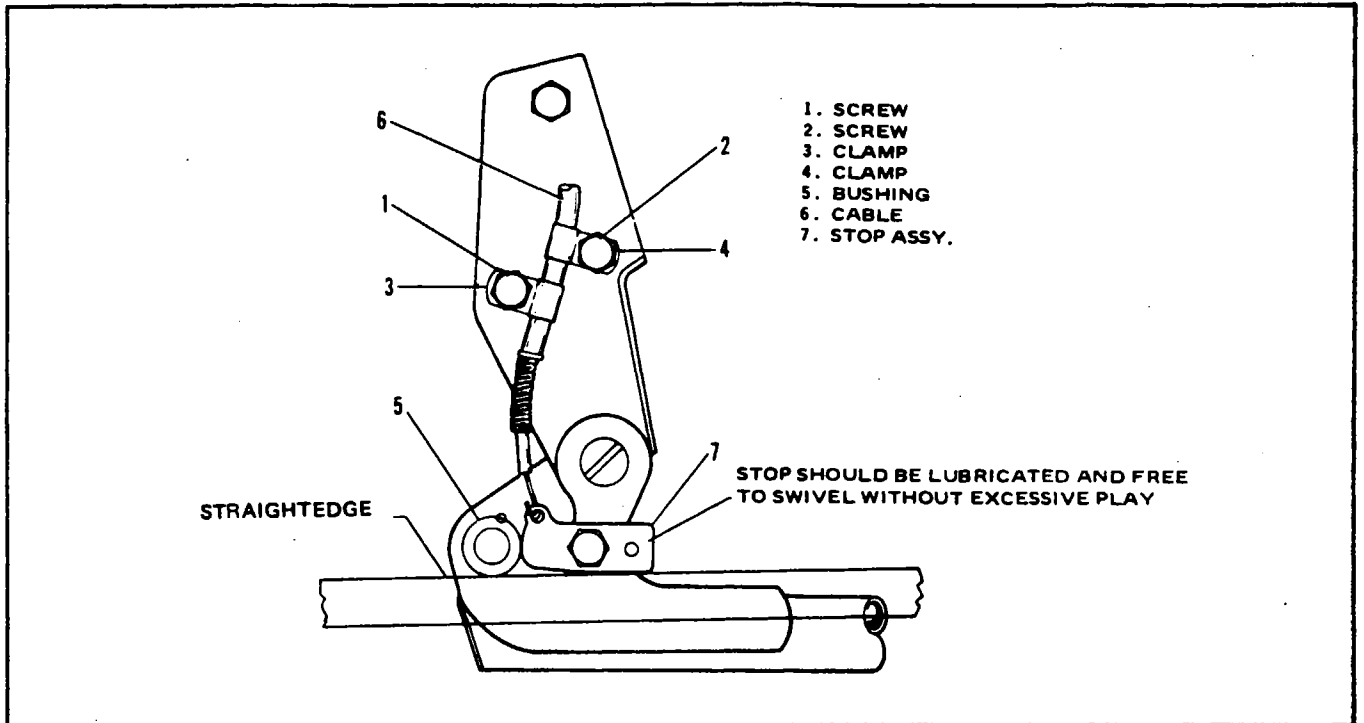

Figure 4-8. Seat Back Lock

THIS SPACE INTENTIONALLY LEFT BLANK

Revised: 8/10/80

1E23

STRUCTURES

4-62. STRUCTURAL REPAIRS. Structural repair methods used may be made in accordance with the regulations set forth in FAA Advisory Circular 43.13-1A. To assist in making repairs, Figure 4-3 identifies the type and thickness of skin structure used. Never make a skin replacement or patch from a material other than the type of the original skin. Original material and thickness is recommended and must result in a surface which is as strong as, or stronger than, the original skin. However, flexibility must be retained so that the surrounding areas will not receive extra stress.

When making major structural repairs, using other than factory manufactured parts, it is recommended the manufacturer be contacted. No major alterations are recommended without contacting the manufacturer.

4-63. FIBERGLASS REPAIRS. The repair procedure in this manual will describe the methods for the repair of fiberglass reinforced structures. Paragraph 4-64 describes Touch-up and Surface Repairs such as blisters, open seams, delaminations, cavities, small holes, and minor damages that have not harmed the fiberglass cloth material. Paragraph 4-65 describes Fracture and Patch Repairs such as puncture, breaks, and holes that have penetrated through the structure and damaged the fiberglass cloth. A repair kit, Part Number 756 729, that will furnish the necessary material for such repairs is available through Piper Aircraft Distributors.

NOTE

Very carefully follow resin and catalyst mixing instructions furnished with repair kit.

4-64. FIBERGLASS TOUCH-UP AND SURFACE REPAIRS.

a. Remove wax, oil, and dirt from around the damaged area with acetone, methylethylketone or equivalent and remove paint to gel coat.

b. The damaged area may be scraped with a fine blade knife or a power drill with a burr attachment to roughen the bottom and sides of the damaged area. Feather the edge surrounding the scratch or cavity. Do not undercut the edge. (If the scratch or cavity is shallow and penetrates only the surface coat, continue to Step f.)

c. Pour a small amount of resin into a jar lid or on a piece of cardboard just enough to fill the area being worked on. Mix an equal amount of milled fiberglass with the resin using a putty knife or stick. Add catalyst, according to kit instructions, to the resin and mix thoroughly. A hypodermic syringe may be used to inject gel into small cavities not requiring fiberglass millings mixed with the gel.

d. Work the mixture of resin, fibers, and catalyst into the damaged area, using the sharp point of a putty knife or stick to press it into the bottom of the hole and to puncture any air bubbles which may be present. Fill the scratch or hole above the surrounding undamaged area about 1/16 inch.

e. Lay a piece of cellophane or waxed paper over the repair to cut off air and start the cure of gel mixture.

f. Allow the gel to cure 10 to 15 minutes until it feels rubbery to the touch. Remove the cellophane and trim flush with the surface, using a sharp razor blade or knife. Replace the cellophane and allow to cure completely for 30 minutes to an hour. The patch will shrink slightly below the structure surface as it cures. (If wax paper is used, ascertain wax is removed from surface.)

- g. Rough up the bottom and edges of the hole with an electric burr attachment or rough sandpaper. Feather hole into surrounding gel coat, do not undercut.
- h. Pour out a small amount of resin, add catalyst and mix thoroughly, using a cutting motion rather than stirring. Use no fibers.
- i. Using the tip of a putty knife or finger tips, fill the hole to about 1/16 inch above the surrounding surface with the gel coat mixture.
- j. Lay a piece of cellophane over the patch to start the curing process. Repeat Step f, trimming patch when partially cured.
- k. After trimming the patch, immediately place another small amount of gel coat on one edge of the patch and cover with cellophane. Then, using a squeegee or the back of a razor blade, squeegee level with area surrounding the patch, leave the cellophane on patch for one or two hours or overnight, for complete cure.
- l. After repair has cured for 24 hours, sand patched area, using a sanding block with fine wet sandpaper. Finish by priming, again sanding and applying color coat.

4-65. FIBERGLASS FRACTURE AND PATCH REPAIRS.

- a. Remove wax, oil, and dirt from around the damaged area with acetone, methylethylketone or equivalent.
- b. Using a keyhole saw, electric saber saw or sharp knife, cut away ragged edges. Cut back to sound material.
- c. Remove paint three inches back from around damaged area.
- d. Working inside the structure, bevel the edges to approximately a 30 degree angle and rough sand the hole and the area around it, using 80 grit dry paper. Feather back for about two inches all around the hole. This roughens the surface for strong bond with patch.
- e. Cover a piece of cardboard or metal with cellophane. Tape it to the outside of the structure, covering the hole completely. The cellophane should face toward the inside of the structure. If the repair is on a sharp contour or shaped area, a sheet of aluminum formed to a similar contour may be placed over the area. The aluminum should also be covered with cellophane.
- f. Prepare a patch of fiberglass mat and cloth to cover an area two inches larger than the hole.
- g. Mix a small amount of resin and catalyst, enough to be used for one step at a time, according to kit instructions.
- h. Thoroughly wet mat and cloth with catalyzed resin. Daub resin on mat first and then on cloth. Mat should be applied against structures surface with cloth on top. Both pieces may be wet out on cellophane and applied as a sandwich. Enough fiberglass cloth and mat reinforcements should be used to at least replace the amount of reinforcements removed in order to maintain the original strength. If damage occurred as a stress crack, an extra layer or two of cloth may be used to strengthen area.
- i. Lay patch over hole on inside of structure; cover with cellophane and squeegee from center to edges to remove all air bubbles and assure adhesion around edge of hole. Air bubbles will show white in the patch and they should all be worked out to the edge. Remove excess resin before it gels on the part. Allow patch to cure completely.
- j. Remove cardboard or aluminum sheet from outside of hole and rough sand the patch and edge of hole. Feather edge of hole about two inches into undamaged area.
- k. Mask area around hole with tape and paper to protect surface. Cut a piece of fiberglass mat about one inch larger than the hole and one or more pieces of fiberglass cloth two inches larger than the hole. Brush catalyzed resin over hole; lay mat over hole and wet out with catalyzed resin. Use a daubing action with brush. Then apply additional layer or layers of fiberglass cloth to build up patch to the surface of structure. Wet out each layer thoroughly with resin.
- l. With a squeegee or broad knife, work out all air bubbles in the patch. Work from center to edge, pressing patch firmly against the structure. Allow patch to cure for 15 to 20 minutes.
- m. As soon as the patch begins to set up, but while still rubbery, take a sharp knife and cut away extra cloth and mat. Cut on outside edge of feathering. Strip cut edges of structure. Do this before cure is complete, to save extra sanding. Allow patch to cure overnight.
- n. Using dry 80 grit sandpaper on a power sander or sanding block, smooth patch and blend with surrounding surface. Should air pockets appear while sanding, puncture and fill with catalyzed resin. A hypodermic needle may be used to fill cavities. Let cure and resand.
- o. Mix catalyzed resin and work into patch with fingers. Smooth carefully and work into any crevices.
- p. Cover with cellophane and squeegee smooth. Allow to cure completely before removing cellophane. Let cure and resand.
- q. Brush or spray a coat of catalyzed resin to seal patch. Sand patch; finish by priming; again sanding and applying color coat.

NOTE

Brush and hands may be cleaned in solvents such as acetone or methylethylketone. If solvents are not available, a strong solution of detergent and water may be used.

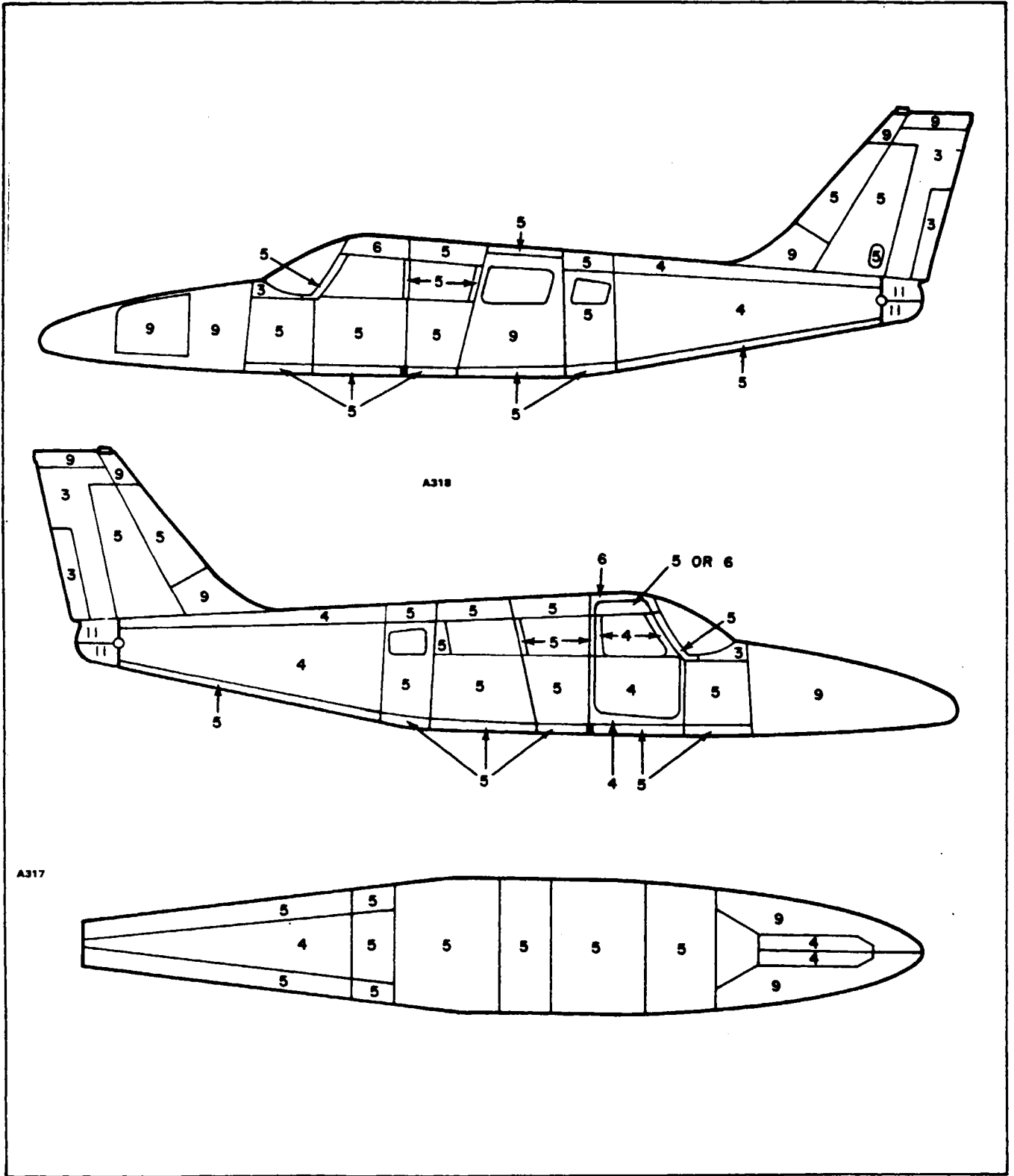

Figure 4-9. Skin Material and Thickness

PIPER SENECA II SERVICE MANUAL

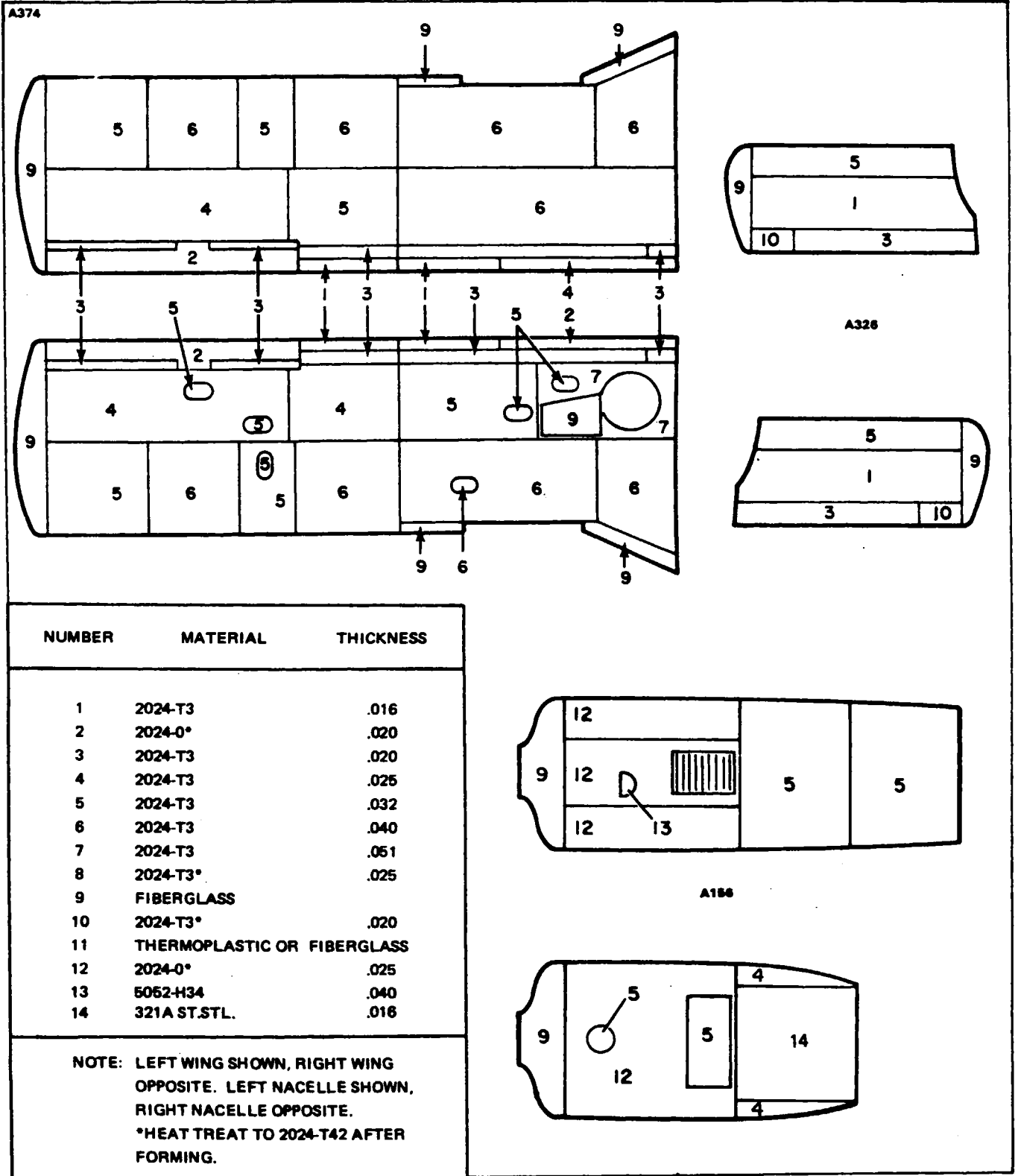

Figure 4-9. Skin Material and Thickness (cont.)

4-66. THERMOPLASTIC REPAIRS. The following procedure will assist in making field repairs to items made of thermoplastic which are used throughout the airplane. A list of material needed to perform these repairs is given along with suggested suppliers of the material. Common safety precautions should be observed when handling some of the materials and tools used while making these repairs.

a. Surface Preparation:

1. Surface dirt and paint if applied must be removed from the item being repaired. Household cleaners have proven most effective in removing surface dirt.

2. Preliminary cleaning of the damaged area with perchlorethylene or VM&P Naptha will generally insure a good bond between epoxy compounds and thermoplastic.

b. Surface Scratches, Abrasion or Ground-in-Dirt: (Refer to Figure 4-10.)

1. Shallow scratches and abraded surfaces are usually repaired by following directions on containers of conventional automotive buffing and rubbing compounds.

2. If large dirt particles are embedded in thermoplastic parts, they can be removed with a hot air gun capable of supplying heat in the temperature range of 300° to 400° F. Use care not to overheat the material. Hold the nozzle of the gun about 1/4 of an inch away from the surface and apply heat with a circular motion until the area is sufficiently soft to remove the dirt particles.

3. The thermoplastic will return to its original shape upon cooling.

c. Deep Scratches, Shallow Nicks and Small Holes: (Less than 1 inch in diameter.) (Refer to Figure 4-11.)

1. Solvent cements will fit virtually any of these applications. If the area to be repaired is very small, it may be quicker to make a satisfactory cement by dissolving thermoplastic material of the same type being repaired in solvent until the desired paste-like consistency is achieved.

2. This mixture is then applied to the damaged area. Upon solvent evaporation, the hard durable solids remaining can easily be shaped to the desired contour by filing or sanding.

3. Solvent adhesives are not recommended for highly stressed areas, on thin walled parts or for patching holes greater than 1/4 inch in diameter.

4. For larger damages an epoxy patching compound is recommended. This type material is a two part, fast curing, easy sanding commercially available compound.

5. Adhesion can be increased by roughing the bonding surface with sandpaper and by utilizing as much area for the bond as possible.

6. The patching compound is mixed in equal portions on a hard flat surface using a figure eight motion. The damaged area is cleaned with perchlorethylene or VM&P Naptha prior to applying the compound. (Refer to Figure 4-12.)

7. A mechanical sander can be used after the compound is cured, providing the sander is kept in constant motion to prevent heat buildup.

8. For repairs in areas involving little or no shear stress, the hot melt adhesives, polyamids which are supplied in stick form may be used. This type of repair has a low cohesive strength factor.

9. For repairs in areas involving small holes, indentations or cracks in the material where high stress is apparent or thin walled sections are used, the welding method is suggested.

10. This welding method requires a hot air gun and ABS rods, to weld, the gun should be held to direct the flow of hot air into the fusion (repair) zone, heating the damaged area and rod simultaneously. The gun should be moved continuously in a fanning motion to prevent discoloration of the material. Pressure must be maintained on the rod to insure good adhesion. (Refer to Figure 4-13.)

11. After the repair is completed, sanding is allowed to obtain a surface finish of acceptable appearance.

PIPER SENECA II SERVICE MANUAL

- d. **Cracks:** (Refer to Figure 4-14.)
1. Before repairing a crack in the thermoplastic part, first determine what caused the crack and alleviate that condition to prevent it recurring after the repair is made.
 2. Drill small stop holes at each end of the crack.
 3. If possible, a double plate should be bonded to the reverse side of the crack to provide extra strength to the part.
 4. The crack should be "V" grooved and filled with repair material, such as solvent cement, hot melt adhesive, epoxy patching compound or hot air welded, whichever is preferred.
 5. After the repair has cured, it may be sanded to match the surrounding surface finish.
- e. **Repairing Major Damage:** (Larger than 1 inch in diameter.) (Refer to Figure 4-15.)
1. If possible a patch should be made of the same material and cut slightly larger than the section being repaired.
 2. When appearances are important, large holes, cracks, tears, etc. should be repaired by cutting out the damaged area and replacing it with a piece of similar material.
 3. When cutting away the damaged area, under cut the perimeter and maintain a smooth edge. The patch and/or plug should also have a smooth edge to insure a good fit.
 4. Coat the patch with solvent adhesive and firmly attach it over the damaged area.
 5. Let the patch dry for approximately one hour before any additional work is performed.
 6. The hole, etc. is then filled with the repair material. A slight overfilling of the repair material is suggested to allow for sanding and finishing after the repair has cured. If patching compound is used the repair should be made in layers, not exceeding a 1/2 inch in thickness at a time, thus allowing the compound to cure and insuring a good solid buildup of successive layers as required.
- f. **Stress Lines:** (Refer to Figure 4-16.)
1. Stress lines produce a whitened appearance in a localized area and generally emanate from the severe bending or impacting of the material. (Refer to Figure 4-17.)
 2. To restore the material to its original condition and color, use a hot air gun or similar heating device and carefully apply heat to the affected area. Do not overheat the material.
- g. **Painting the Repair:**
1. An important factor in obtaining a quality paint finish is the proper preparation of the repair and surrounding area before applying any paint.
 2. It is recommended that parts be cleaned prior to painting with a commercial cleaner or a solution made from one-fourth cup of detergent mixed with one gallon of water.
 3. The paint used for coating thermoplastic can be either lacquers or enamels depending on which is preferred by the repair facility or customer. (See NOTE.)

NOTE

It is extremely important that solvent formulations be considered when selecting a paint, because not all lacquers or enamels can be used satisfactorily on thermoplastics. Some solvents used in the paints can significantly affect and degrade the plastic properties.

4. Another important matter to consider is that hard, brittle coatings that are usually best for abrasion resistance should not be used in areas which incur high stress, flexing or impact. Such coatings may crack, thus creating a weak area.

PIPER SENECA II SERVICE MANUAL

TABLE IV-III. LIST OF MATERIALS (THERMOPLASTIC REPAIR)

ITEMS	DESCRIPTIONS	SUPPLIERS
Buffing and Rubbing Compounds	Automotive Type - DuPont #7 Ram Chemical #69 x 1 Mirror Glaze #1	DuPont Company Wilmington, Del. 19898 Ram Chemicals Gardena, Cal. 90248 Mirror Bright Polish Co., Inc. Irvin, Cal. 92713
Cleaners	Fantastic Spray Perchloroethylene VM&P Naphtha (Lighter Fluid)	Obtain From Local Suppliers
ABS-Solvent Cements	Solarite #11 Series	Solar Compounds Corp. Linden, N.J. 07036
Solvents	Methylene Ketone Methylene Chloride Acetone	Obtain From Local Suppliers
Epoxy Patching Compound	Solarite #400	Solar Compounds Corp. Linden, N.J. 07036
Hot Melt Adhesives Polyamids and Hot Melt Gun	Stick Form 1/2 in. dia. 3 in. long	Sears Roebuck & Co. or Most Hardware Stores
Hot Air Gun	Temp. Range 300° to 400°F	Local Suppliers

Revised: 8/10/80

1F7

STRUCTURES

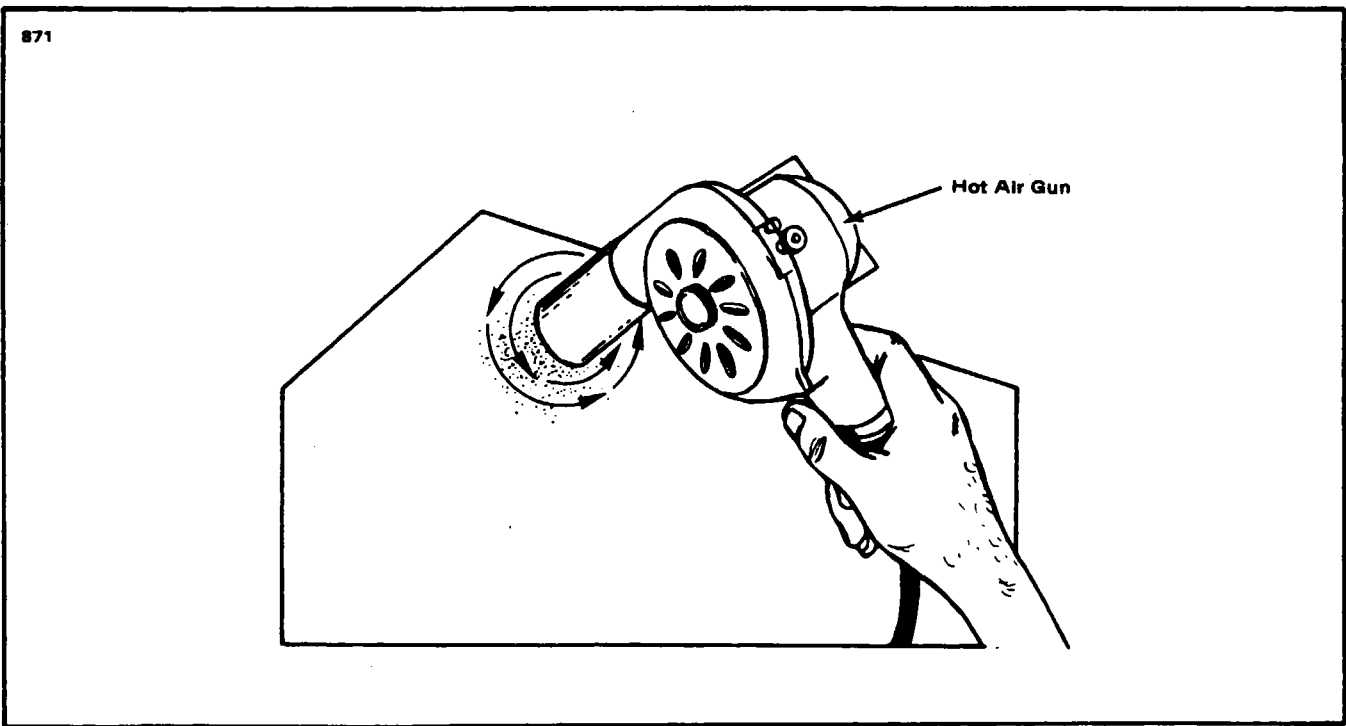

Figure 4-10. Surface Scratches, Abrasions or Ground-in-Dirt.

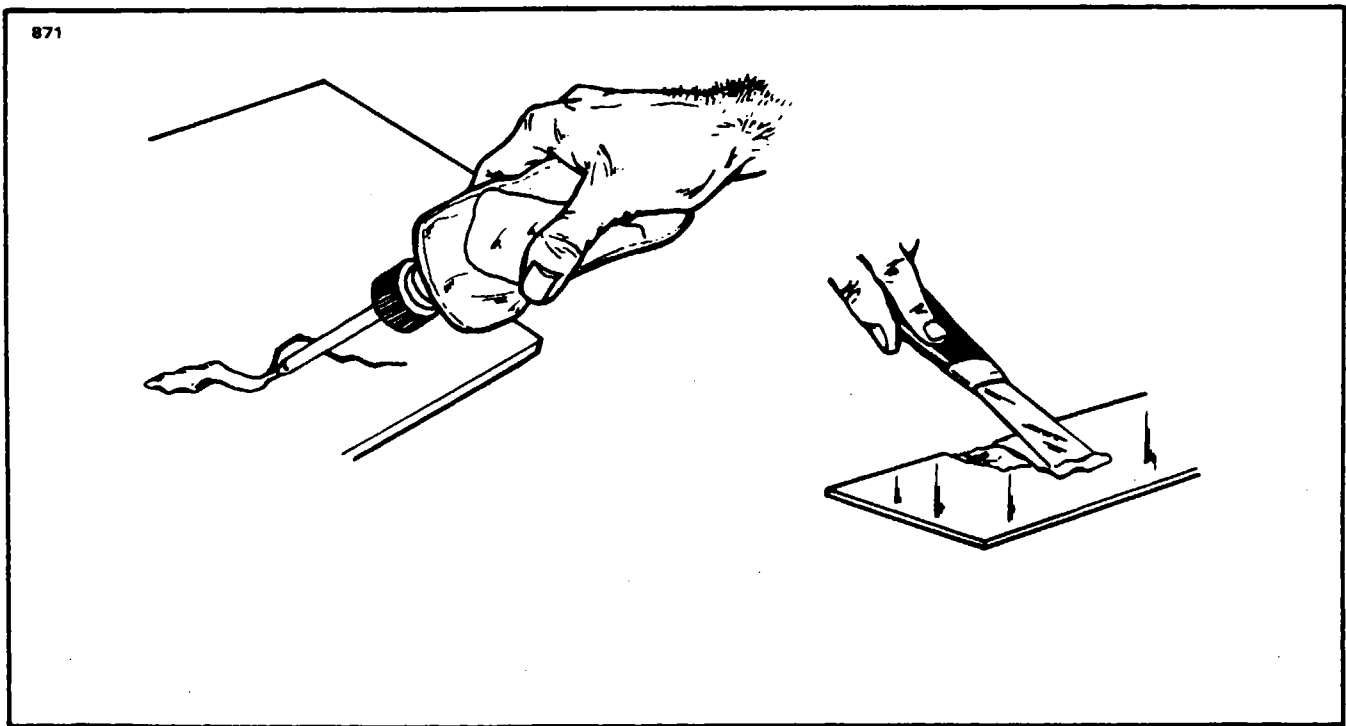

Figure 4-11. Deep Scratches, Shallow Nicks and Small Holes.

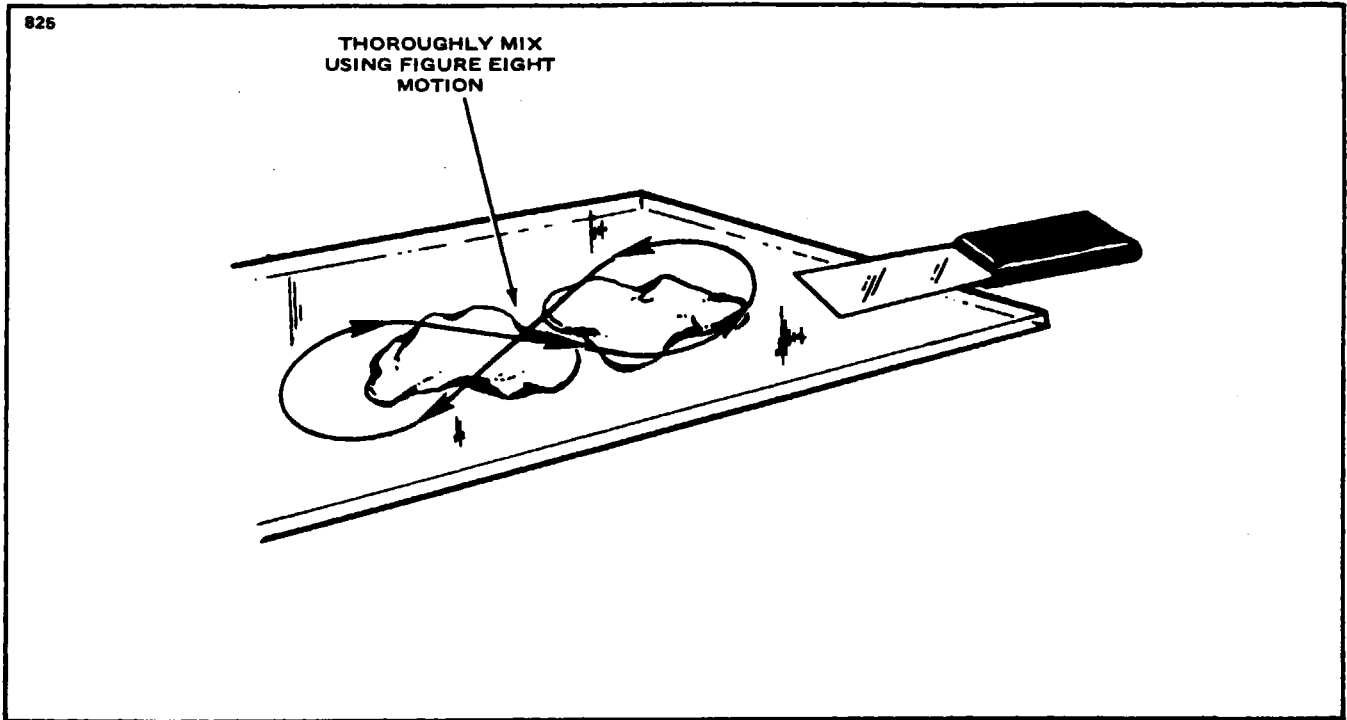

Figure 4-12. Mixing of Epoxy Patching Compound.

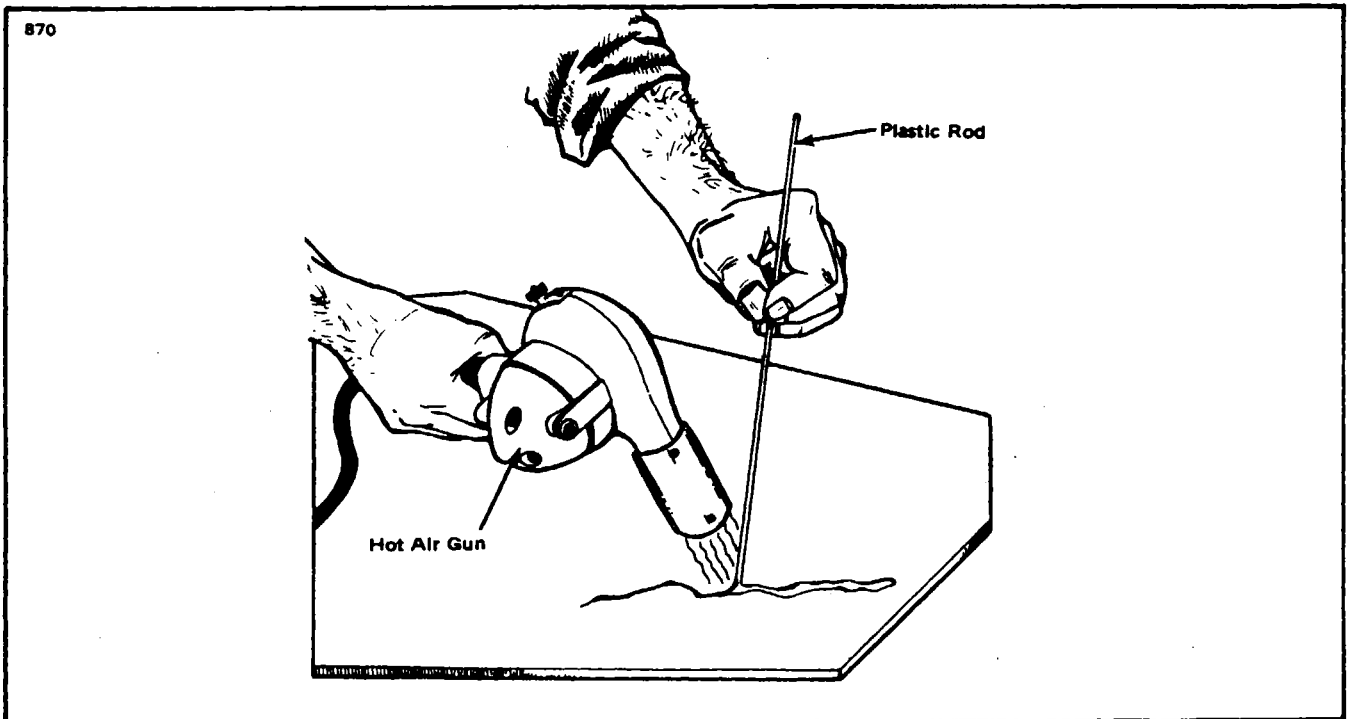

Figure 4-13. Welding Repair Method.

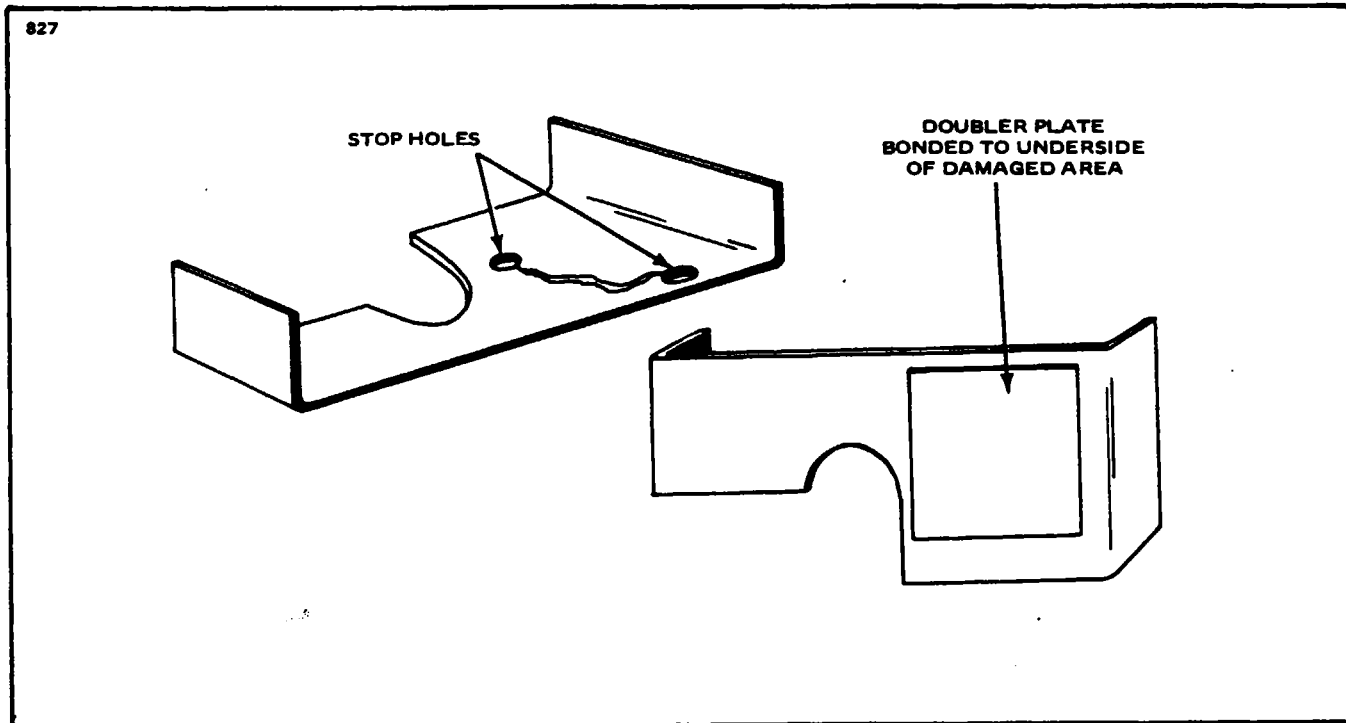

Figure 4-14. Repairing of Cracks.

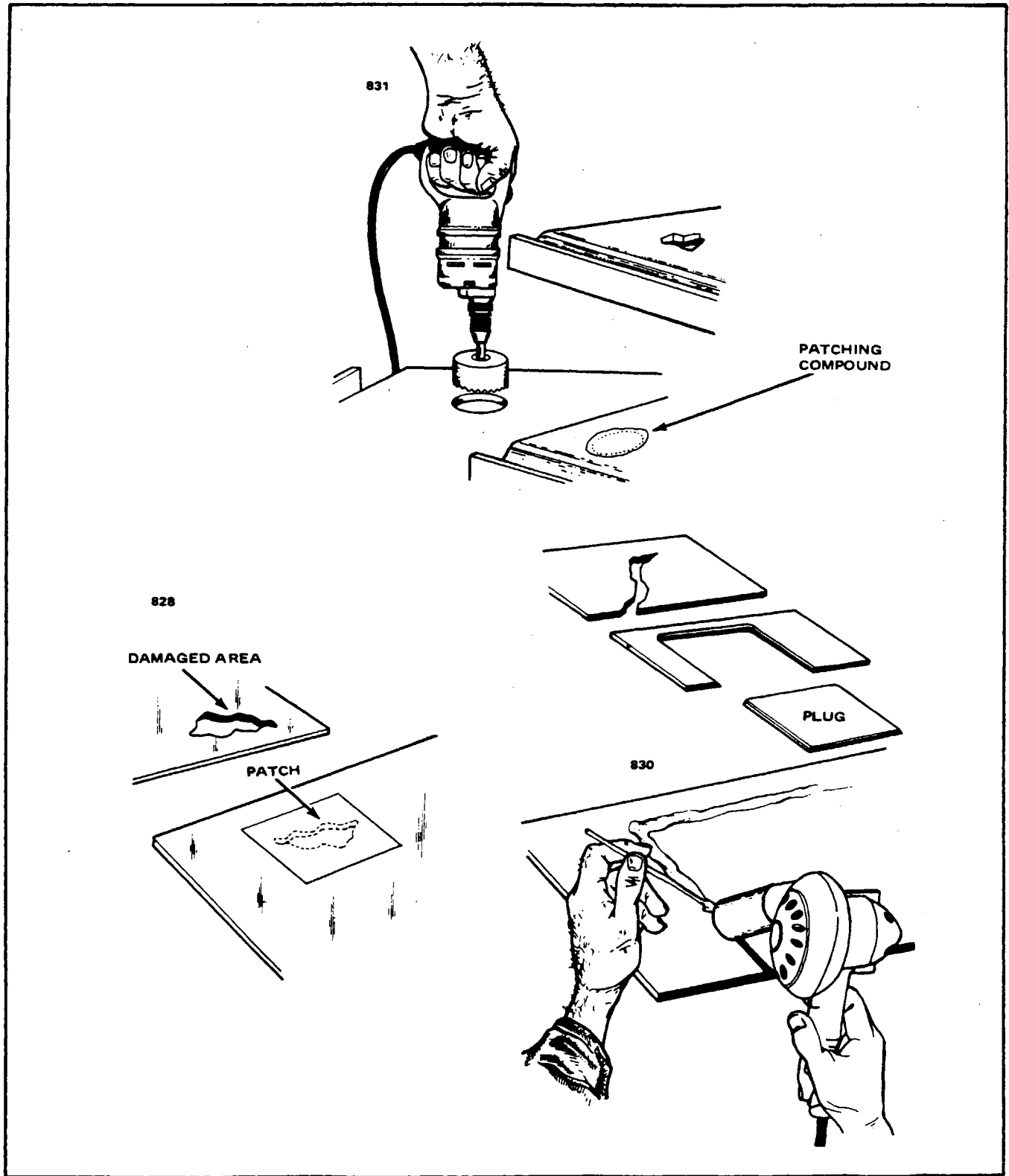

Figure 4-15. Various Repairs.

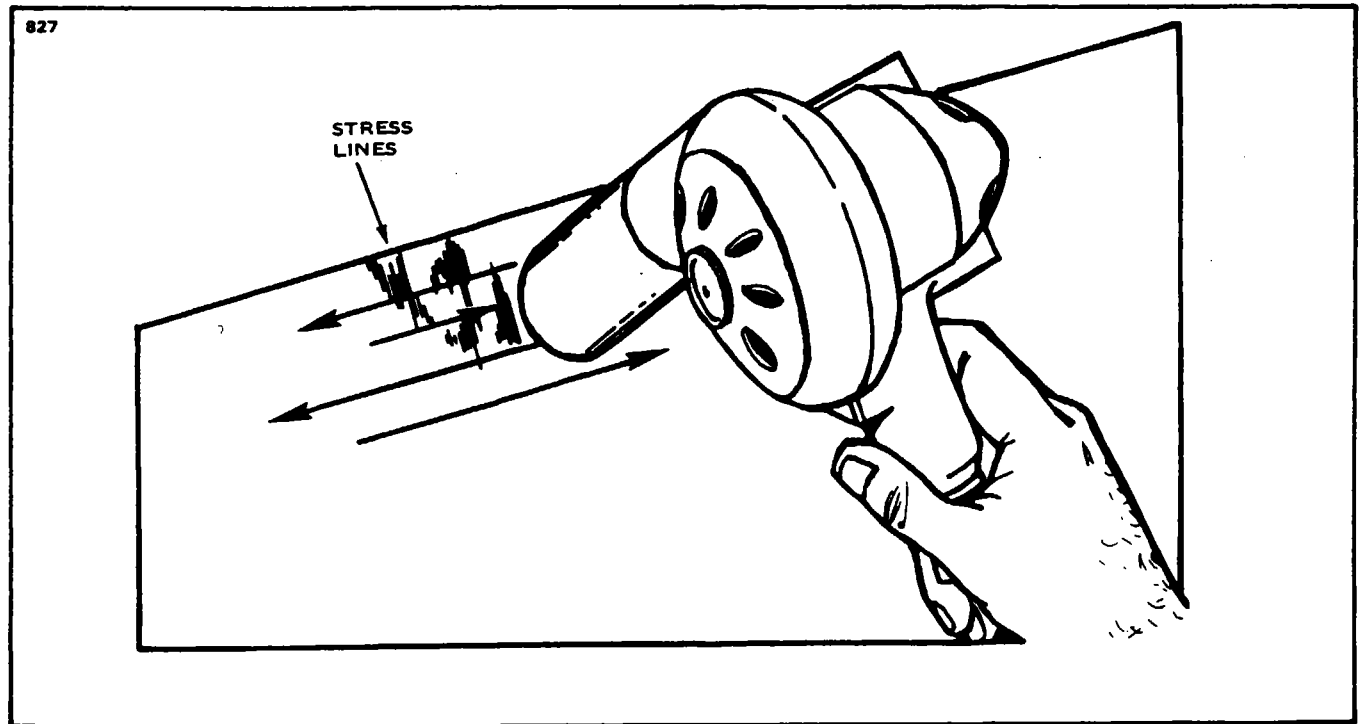

Figure 4-16. Repair of Stress Lines.

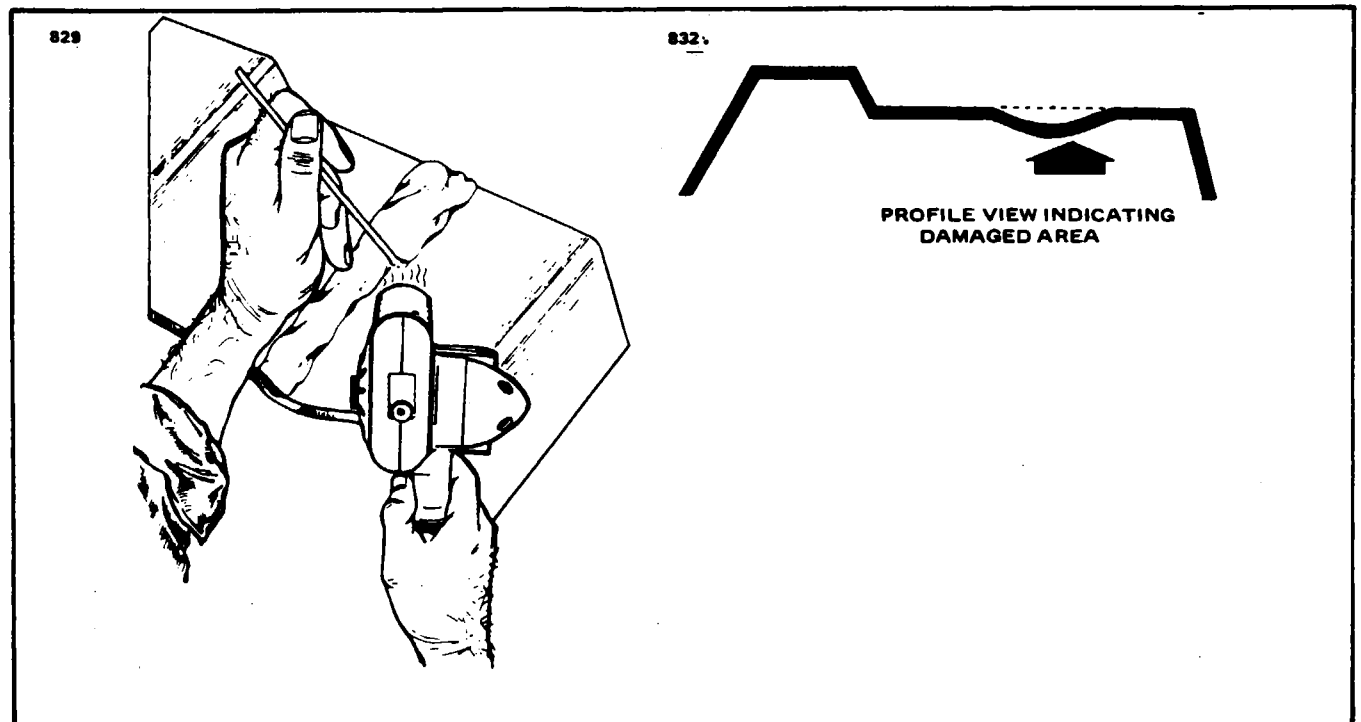

Figure 4-17. Repair of Impacted Damage.

4-67. SAFETY WALK REPAIR.

4-68. SURFACE PREPARATION FOR LIQUID SAFETY WALK.

- a. Clean all surfaces with a suitable cleaning solvent to remove dirt, grease and oils. Solvents may be applied by dipping, spraying or mopping.
- b. Insure that no moisture remains on the surface by wiping with a clean dry cloth.
- c. Outline the area to which the liquid safety walk compound is to be applied, and mask adjacent surfaces.

NOTE

Newly painted surfaces shall be allowed to dry for 2.5 hours minimum prior to the application of the safety walk.

4-69. PRODUCT LISTING FOR LIQUID SAFETY WALK COMPOUND.

- a. Suggested Solvents:
 - Safety solvent per MIL-S18718
 - Sherwin Williams Lacquer Thinner R7KC120
 - Glidden Thinner No. 207
- b. Safety Walk Material:
 - Walkway Compound, Nonslip and Walkway Matting, Nonslip (included in Piper Part No. 179 872)

4-70. APPLICATION OF LIQUID SAFETY WALK COMPOUND. Liquid safety walk compound shall be applied in an area free of moisture for a period of 24 hours minimum after application. Do not apply when surface to be coated is below 50° F. Apply liquid as follows:

- a. Mix and thin the liquid safety walk compound in accordance with the manufacturer's instructions on the container.
- b. Coat the specified surfaces with a smooth, unbroken film of the liquid safety walk compound. A nap type roller or a stiff bristle brush is recommended using fore and aft strokes.
- c. Allow the coating to dry for 15 minutes to one hour before recoating or touch-up, if required after application of the initial coating.
- d. After recoating or touch-up, allow the coating to dry for 15 minutes to one hour before removing masking.

NOTE

The coated surface shall not be walked on for six hours minimum after application of final coating.

PIPER SENECA II SERVICE MANUAL

4-71. SURFACE PREPARATION FOR PRESSURE SENSITIVE SAFETY WALK. The areas to which the pressure sensitive safety walk is to be installed must be free from all contaminants and no moisture present. If liquid safety walk is installed the area must be prepared as follows:

- a. Area must be masked off to protect painted surfaces.
- b. Apply suitable stripper MEK Federal Spec. TT-M-261, U.S. Rubber No. 3339 to wingwalk compound. As compound softens, remove by using putty knife or other suitable tool.
- c. Area must be clean and dry prior to painting.
- d. Prime and paint area.

NOTE

Newly painted surfaces, shall be allowed to dry for 2.5 hours minimum prior to the application of the safety walk.

4-72. APPLICATION OF PRESSURE SENSITIVE SAFETY WALK. (Kit 763 849V) Wipe area with a clean dry cloth to insure that no moisture remains on surface. Do not apply when surface temperature is below 50°F. Apply pressure sensitive safety walk as follows:

- a. Peel back the full width of the protective liner approximately 2 inches from the leading edge of the safety walk.
- b. Apply the safety walk to the wing area, begin at the leading edge, insure proper alignment and position from wing lap.
- c. Remove the remaining protective liner as the safety walk is being applied from front to back of wing area.
- d. Roll firmly with a long handled cylindrical brush in both lengthwise directions. Make sure all edges adhere to the wing skin.
- e. Install leading edge retainer by inserting between wing leading edge fairing and forward wing spar. Hold all parts in position by using existing fairing screws.

4-73. CONTROL SURFACE BALANCING.

4-74. CHECKING CONTROL SURFACE BALANCE. The movable control surfaces have been statically balanced at the time of installation at the factory and normally should not require rebalancing. Where possible the control surfaces were set with the balance weight on the heavy side of the limits to permit limited repair or paint touch-up without adjusting the balance weight. It should be noted, however, that spare control surfaces are delivered unpainted and the static balance will not necessarily fall within the limits provided. This is more pronounced on the stabilators and rudders. The completed control surface including paint should be within the limits given in Table IV-I. If the surface is not to be painted, the balance weight will probably require adjustment. All replacement control surfaces or surfaces that have been repainted or repaired should be rebalanced according to the procedures given in Paragraphs 4-74 thru 4-78. The static balance of the surfaces must be as specified in Table IV-I.

Before balancing any control surface, it must be complete including tip, trim/servo tabs as applicable and tab actuating arms or push rods with bearings as applicable and all optional equipment which is mounted on or in the control surface when it is flown, including paint, position lights and wiring, static wicks, scuff boots, etc.

If optional equipment is added or removed after balancing, the control surface must be rebalanced. During balancing, trim/servo tabs must be maintained in the neutral position.

4-75. BALANCING EQUIPMENT (Refer to Figure 4-18).

a. Insure that the control surface is in its final flight configuration, static wicks, trim tabs, trim tab push pull rod, and control surface tip (as applicable) should be installed. The surface should be painted and trim/servo tabs should be in the neutral position.

NOTE

Because paint is a considerable balance factor, it is recommended that existing paint be removed prior to repainting a control surface.

- b. Place hinge bolts through control surfaces and place control surface on a holding fixture.
- c. Avoiding rivets, place the balancing tool on the control surface with the tool's hinge centerline directly over the hinge line of the control surface.
- d. Adjust the movable trailing edge support to fit the width of the control surface. Tighten the set screw on the trailing edge support.
- e. Adjust the trailing edge support vertically until the beam is parallel with the control surface chord line.
- f. Remove the tool from the control surface and balance the tool itself by adding or removing nuts or washers from the beam balancing bolt. When balancing the tool, the movable weight must be at the bar's hinge centerline.
- g. After balancing the tool, reattach it to the control surface. Keep the beam positioned 90° from the control surface hinge line.
- h. Determine balance of control surface by sliding movable weight along the balance beam.
- i. Read the scale when the bubble in the level has been centered. Since the movable weights weighs three pounds, every inch it is moved from the center of the beam equals three inch-pounds of force.

PIPER SENECA II SERVICE MANUAL

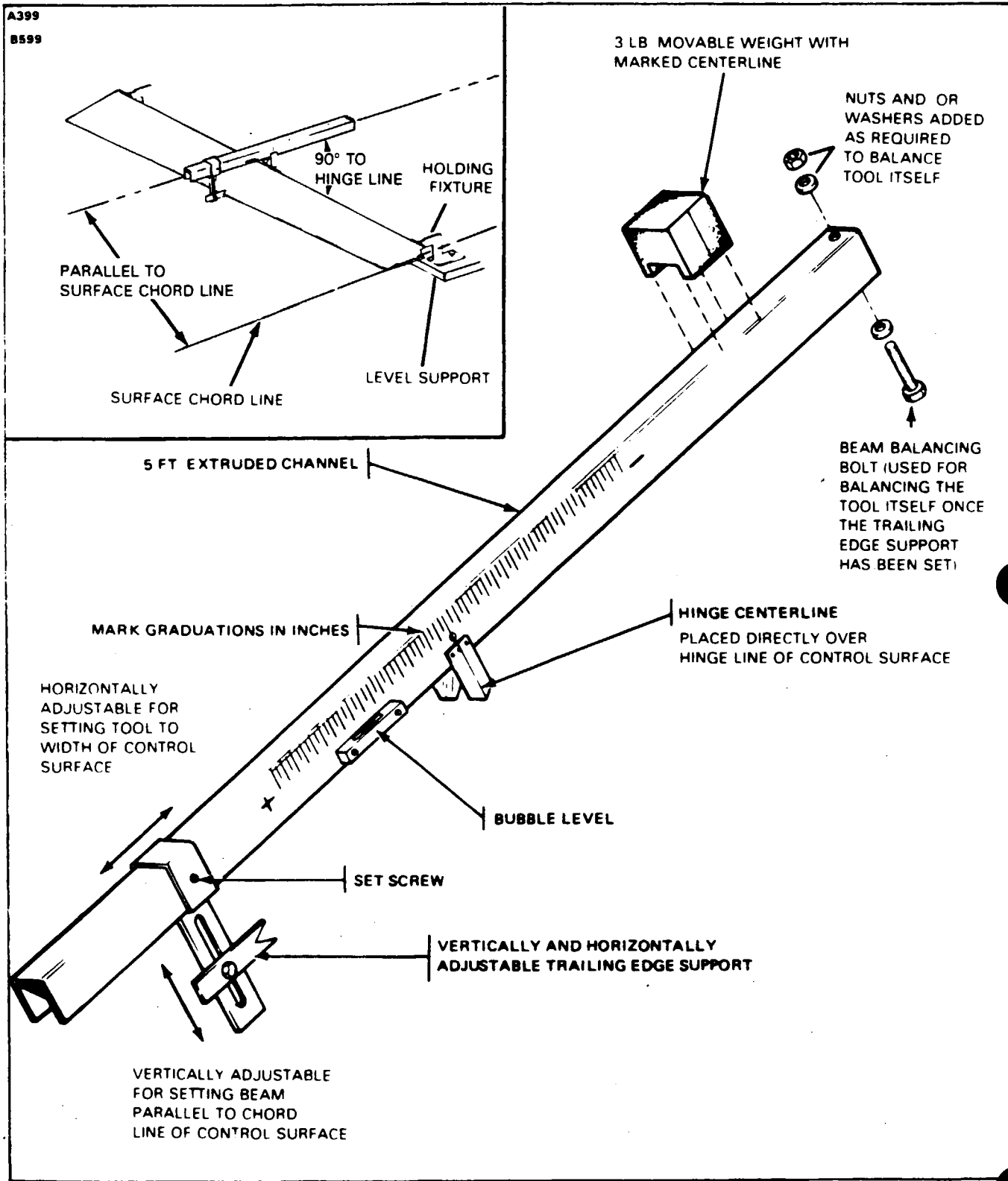

Figure 4-18. Control Surface Balance Tool

Revised: 12/08/83

1F16

STRUCTURES

TABLE IV-IV. BALANCE SPECIFICATIONS

SURFACE	STATIC BALANCE LIMITS (IN.-LBS.)	
	Leading Edge Heavy	Trailing Edge Heavy
Ailerons up through 34-7670362	0.00	to -2.75
Ailerons 34-777001 and up	+5.00	to -2.75
Stabilators*	0.00	to -13.00
Rudders	-20.00	to -35.00

*With or without deicer boots installed. See Figure 4-20.

PP550011-1

4-76. **BALANCING AILERONS.** (Refer to Figure 4-19.) Position the aileron on the balancing fixture in a draft free area and in a manner which allows unrestricted movement of the aileron on the hinge bearings. Place the tool on the aileron, avoid rivets and keep the beam perpendicular to the hinge centerline. Calibrate the tool as described in Paragraph 4-75. Read the scale when the bubble level has been centered by adjustment of the movable weight and determine the static balance. If the static balance is not within the limits specified in Table IV-II, proceed as follows:

a. **Leading Edge Heavy:** This condition is highly improbable; recheck measurements and calculations.

b. **Trailing Edge Heavy:** There are no provisions for adding weight to counteract a trailing edge heavy condition; therefore, it will be necessary to determine the exact cause of the unbalance. If the aileron is too heavy because of painting over old paint, it will be necessary to strip all paint from the aileron and repaint. If the aileron is too heavy resulting from repair to the skin or ribs, it will be necessary to replace all damaged parts and recheck the balance.

4-77. **BALANCING RUDDER.** (Refer to Figure 4-19.) To balance the rudder, the assembly must be complete including the tip assembly and all attaching screws, the position light wiring and trim tab and push rod. Tape the trim tab in neutral position with a small piece of tape. Place the complete assembly horizontally on knife edge supports in a draft free area in a manner that allows unrestricted movement. Place the tool on the rudder with the beam perpendicular to the hinge centerline. Do not place the tool on the trim tab. Calibrate the tool as described in Paragraph 4-75. Read the scale when the bubble level has been centered by adjustment of the movable weight and determine the static balance limit. If the static balance is not within the limits given in Table IV-II, proceed as follows:

a. **Nose Heavy:** This condition is highly improbable; recheck calculations and measurements.

b. **Nose Light:** In this case, the mass balance weight is too light or the rudder is too heavy because of painting; it will be necessary to strip the paint and repaint. If the rudder is too heavy as a result of repairs, the repair must be removed and the damaged parts replaced.

PIPER SENECA II SERVICE MANUAL

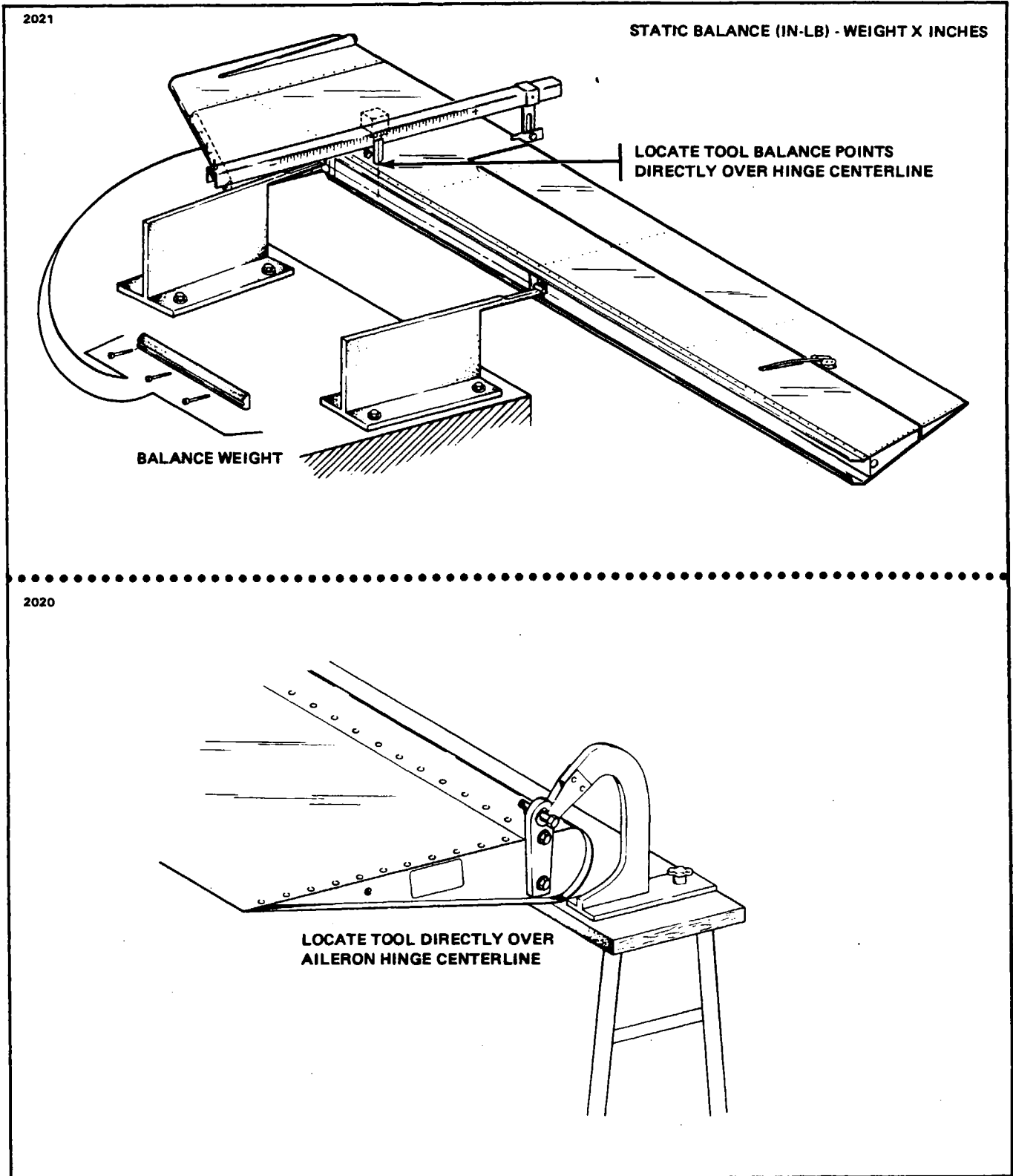

Figure 4-19. Aileron and Rudder Balance Configuration

Reissued: 10/11/79

STRUCTURES

1F18

Island Enterprises

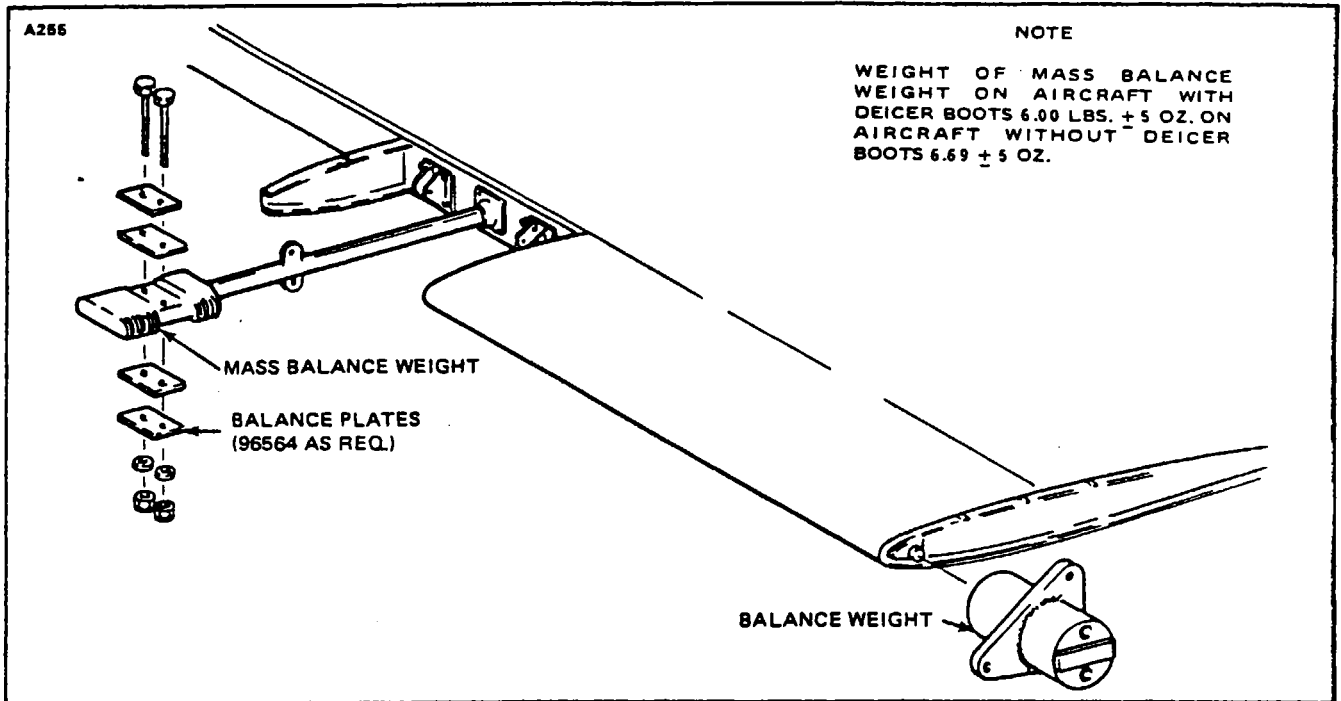

Figure 4-20. Stabilator Balance Configuration

4-78. **BALANCING STABILATOR.** (Refer to Figure 4-20.) To balance the stabilator, the assembly must be complete including the trim tab, the tab push rod and end bearing, stabilator tips and all attaching screws. Before balancing, tape the trim tab in neutral position with a small piece of tape. Place the complete assembly on the knife edge supports in a draft free area in a manner that allows unrestricted movement. Place the tool on the stabilator with the beam perpendicular to the hinge centerline. Do not place the tool on the trim tab. Calibrate the tool as described in Paragraph 4-75. Read the scale when the bubble level has been centered by adjustment of the movable weight and determine the static balance limit. If the static balance is not within the limits given in Table IV-II, proceed as follows:

- a. If the stabilator is out of limits on the leading edge heavy side, remove balance plates from the mass balance weight until the static balance is within limits. Do not attempt to adjust the stabilator tip balance weight.
- b. If the stabilator is out of limits on the trailing edge heavy side, add balance plates to the mass balance weight until the static balance is within limits.

PPS5001L-1

4-79. **CHECKING FREE PLAY OF CONTROL SURFACES.** The following checks are recommended before balancing to determine how much free play exists in the control surfaces.

- a. **Stabilator:** Neither stabilator half is allowed any free play at its attachment points fore or aft, up or down, or left or right.
- b. **Stabilator and Rudder Tabs:** Move the stabilator or rudder to one of its limits of travel and secure. Insert a scale type straight edge in the groove between the surface and its tab. Grasping the trailing edge of the tab, gently move it, marking the travel limits. The overall travel must not exceed 0.125 inch.

1F20
INTENTIONALLY LEFT BLANK.

SECTION V

SURFACE CONTROLS

Paragraph		Aerofiche Grid No.
5-1.	Introduction	1F22
5-2.	Description	1F22
5-3.	Control Column Assembly	1G2
	5-4. Removal of Control Column Assembly	1G2
	5-5. Installation of Control Column Assembly	1G2
5-6.	Aileron Controls	1G3
	5-7. Removal of Aileron Control Cables	1G3
	5-8. Installation of Aileron Control Cables	1G7
	5-9. Removal of Aileron Bellcrank Assembly	1G8
	5-10. Installation of Aileron Bellcrank Assembly	1G8
	5-11. Rigging and Adjustment of Aileron Controls	1G9
5-12.	Stabilator Controls	1G11
	5-13. Removal of Stabilator Control Cables	1G11
	5-14. Installation of Stabilator Control Cables	1G15
	5-15. Rigging and Adjustment of Stabilator Controls	1G16
5-16.	Stabilator Trim Controls	1G17
	5-17. Removal of Stabilator Trim Assembly (Forward)	1G17
	5-18. Installation of Stabilator Trim Assembly (Forward)	1G18
	5-19. Removal of Stabilator Trim Controls (Aft)	1G19
	5-20. Installation of Stabilator Trim Controls (Aft)	1G20
	5-21. Rigging and Adjustment of Stabilator Trim	1G20
5-22.	Rudder Pedal Assembly	1G21
	5-23. Removal of Rudder Pedal Assembly	1G21
	5-24. Installation of Rudder Pedal Assembly	1G21
5-25.	Rudder Controls	1G23
	5-26. Removal of Rudder Control Cables	1G23
	5-27. Installation of Rudder Control Cables	1G24
	5-28. Rigging and Adjustment of Rudder Controls	1H3
5-29.	Rudder Trim Controls	1H5
	5-30. Removal of Rudder Trim Controls (Forward)	1H5
	5-31. Installation of Rudder Trim Controls (Forward)	1H5
	5-32. Removal of Rudder Trim Controls (Aft)	1H6
	5-33. Installation of Rudder Trim Controls (Aft)	1H6
	5-34. Rigging and Adjustment of Rudder Trim Controls	1H7
5-35.	Wing Flap Controls	1H8
	5-36. Removal of Wing Flap Controls	1H8
	5-37. Installation of Wing Flap Controls	1H10
	5-38. Rigging and Adjustment of Wing Flaps	1H11

Revised: 8/10/80

SECTION V

SURFACE CONTROLS

5-1. INTRODUCTION. This section explains the removal, installation, and rigging and adjustment procedures for the control surfaces of the various structural components. For the removal and installation of the structural surfaces of the airplane, refer to Section IV. The assemblies need not be removed in order of paragraph since each paragraph describes the individual removal and installation of the various assemblies. The following tips may be helpful in the removal and installation of the various assemblies:

a. It is recommended, though not always necessary, to level and place the airplane on jacks during rigging and adjustment, especially when using a bubble protractor or level.

b. Remove the turnbuckle barrels from cable ends before withdrawing the cable through the structures.

c. Tie a cord to the cable end before drawing cable through structures to facilitate reinstallation of cable.

d. When turnbuckles have been set to correct tension, no more than three threads should be exposed from either end of the turnbuckle barrel. Locking clips, after installation, should be checked for security by trying to remove the clips using fingers only. Both locking clips may be inserted in the same hole of the turnbuckle barrel, or they may be installed in opposite holes. After being removed, locking clips should be discarded, not reused.

e. Assemble and adjust a turnbuckle so that each terminal is screwed on approximately equal distance into the barrel. During adjustment, do not turn the terminals in such a manner as to put a permanent twist in the cables.

f. When installing rod end jam nuts refer to Figure 5-1a for proper installation method. After adjusting a jam nut, insure that it is securely tightened and thoroughly inspected.

g. If the push rod or rod end has an inspection hole, the screw should be screwed in far enough to pass the hole. This can be determined visually or by feel, inserting a piece of wire into this inspection hole. If there is no inspection hole, there should be a minimum of 3/8 inch thread engagement.

NOTE

Cable rigging tensions specified in this section should be corrected to ambient temperature in the area where the tension is being checked using Table V-II.

5-2. DESCRIPTION. The Seneca II is controlled in flight by the use of three standard primary control surfaces, consisting of ailerons, stabilator and rudder. Operation of these controls is through the movement of the control column tee bar assembly and rudder pedals. On the forward end of each control column is a sprocket assembly. A chain is wrapped around the sprockets to connect the right and left controls and then back to idler sprockets on the column's tee bar, which in turn connect to the aileron primary control cables. The cables operate the aileron bellcrank and push-pull rods. The stabilator is controlled by a cable connected to the bottom of the tee bar assembly and at the balance arm of the stabilator. Cables also connect the rudder pedals with the rudder sector. Provisions for directional and longitudinal trim are provided by adjustable trim mechanisms for the stabilator and rudder. Both the stabilator and rudder trim are controlled by individual wheel and drum assemblies mounted on the floor tunnel between the front seats. Cables routed aft from the drums to the tail cone operate the particular screw assembly which in turn moves the stabilator or rudder trim tab.

The wing flap system consists of an operating handle, a cable routed from the handle to a torque tube and push-pull rods. Through the push-pull rods and torque tube, the flaps are interconnecting and can be positioned in three locations of 10, 25 and 40 degrees.

1986

TABLE V-I. CONTROL SURFACE TRAVELS AND CABLE TENSIONS

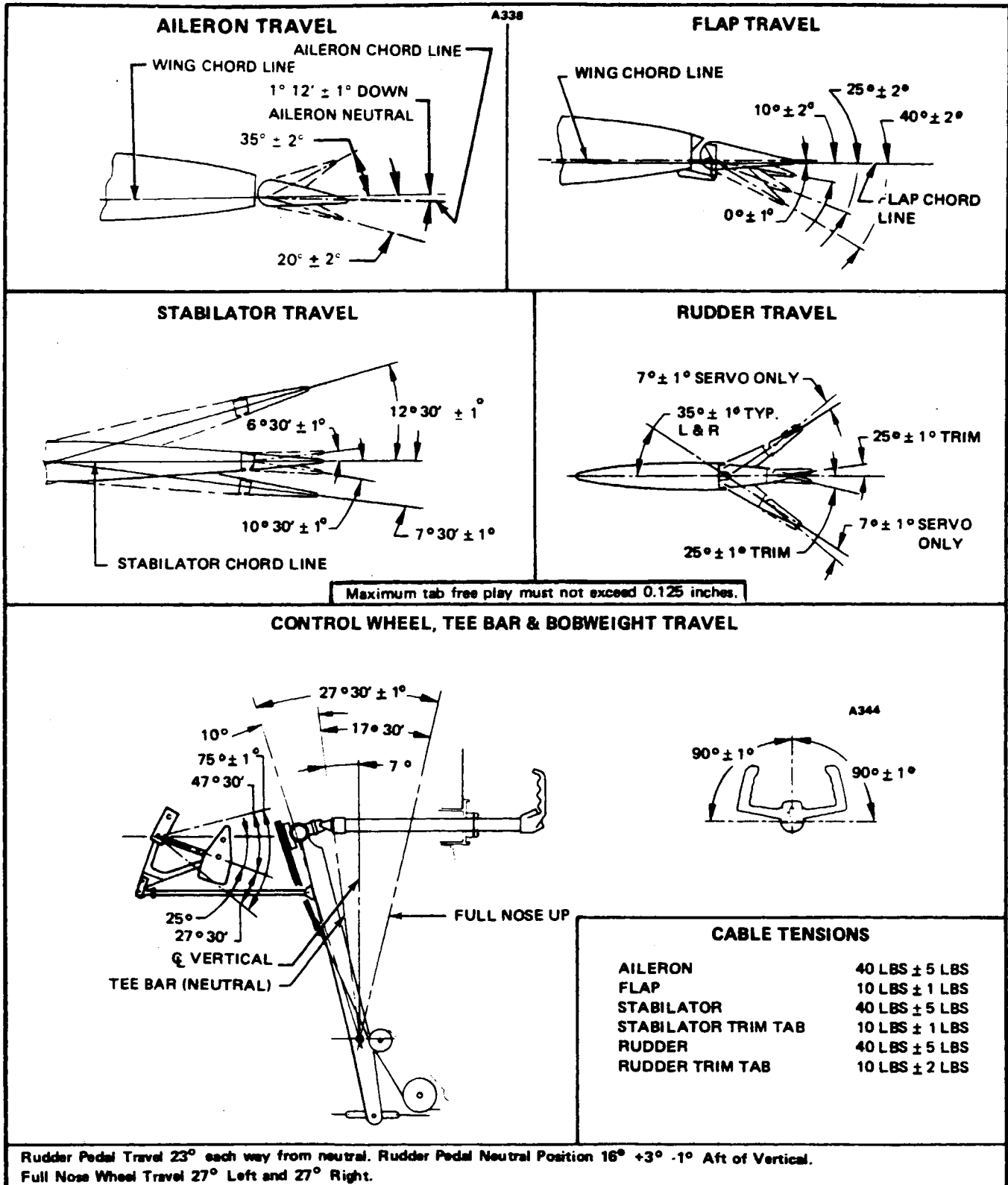

Revised: 8/10/80

SURFACE CONTROLS

PIPER SENECA II SERVICE MANUAL

TABLE V-II. CABLE TENSION VS. AMBIENT TEMPERATURE

PPS5009-2

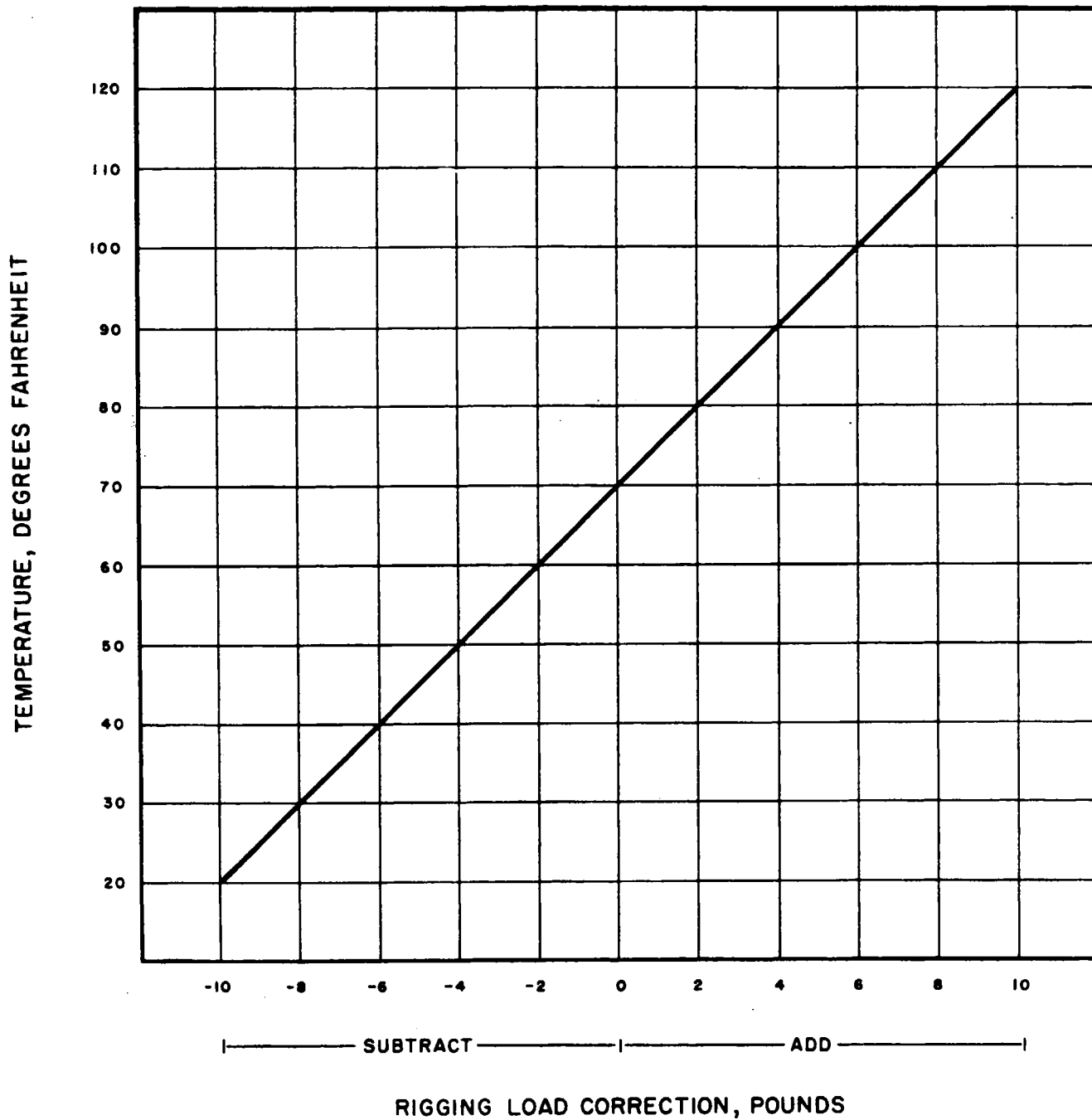

Reissued: 10/11/79

SURFACE CONTROLS

1F24

Island Enterprises

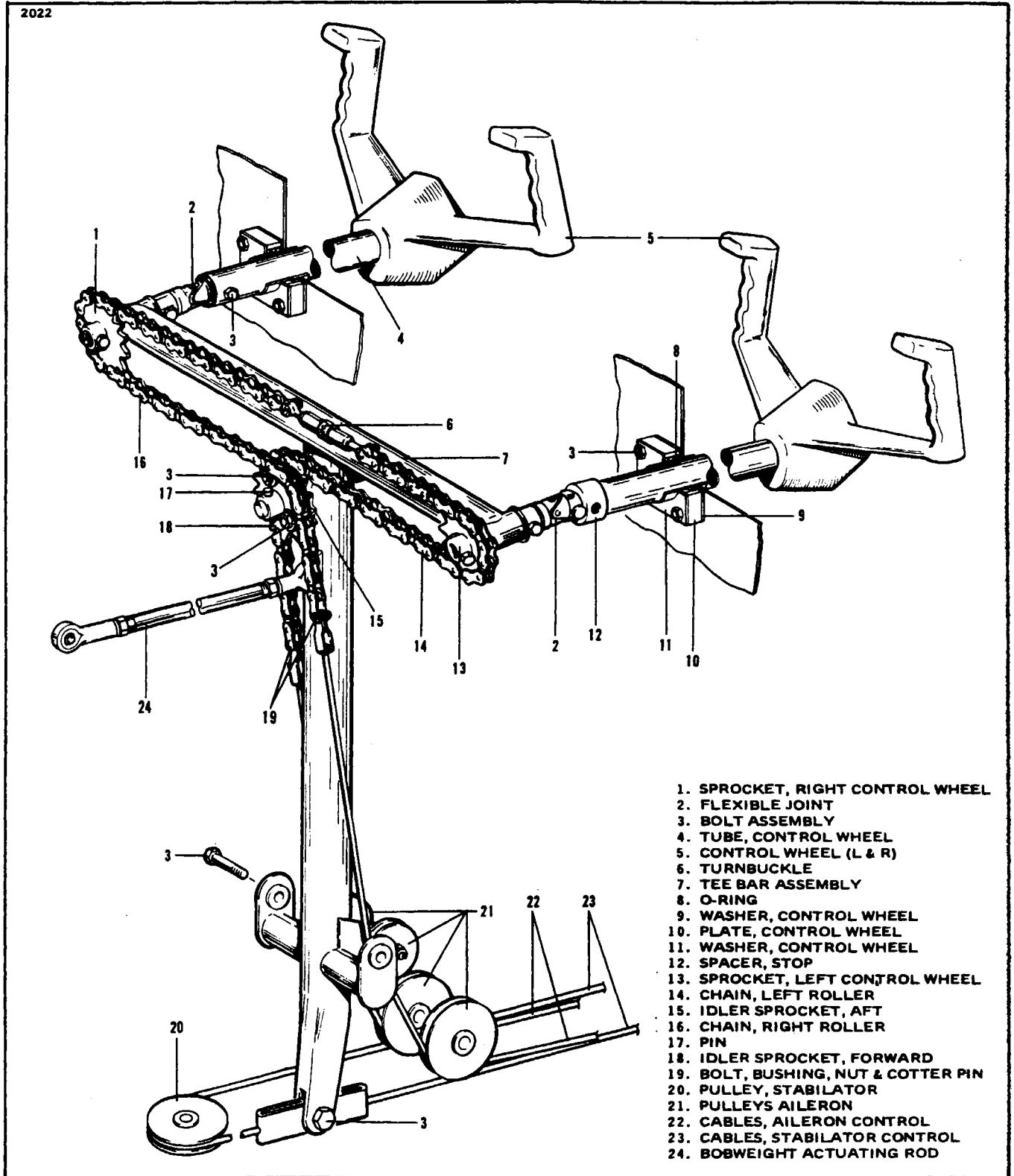

Figure 5-1. Control Column Assembly

Reissued: 10/11/79

SURFACE CONTROLS

5-3. CONTROL COLUMN ASSEMBLY.

5-4. REMOVAL OF CONTROL COLUMN ASSEMBLY. (Refer to Figure 5-1.)

- a. To remove either control wheel (5) with tube (4), the following procedure may be used:
 1. Separate the control wheel tube (4) from the flexible joint (2) that is located on either side of the tee bar assembly (7) by removing the nut, washer and bolt (3). Pull the tube from the flexible joint.
 2. If removing the left control tube, slide the stop (12) from the tube.
 3. Should wires for the various Autopilot systems be installed in the control tube, disconnect them at the quick disconnect terminals behind the instrument panel. Draw the wires back into the tube and back out through the forward end of the tube.
 4. Remove the control wheel assembly from the instrument panel.
- b. The tee bar (7) with assembled parts may be removed from the airplane by the following procedure:
 1. Remove the access panel to the aft section of the fuselage.
 2. Relieve cable tension from the stabilator control cables (23) at one of the stabilator cable turnbuckles in the aft section of the fuselage.
 3. Relieve tension from the aileron control cables (22) and chains (16 and 14) at the turnbuckle (6) that connects the chains at the top of the tee bar (7).
 4. Disconnect the control chains from the control cables where the chains and cables join by removing the cotter pins, nuts, bolts and bushings.
 5. If the control wheel assemblies have not been previously disconnected from the tee bar assembly, separate the control wheel tubes (4) at the flexible joints (2) by removing the nuts, washers and bolts (3).
 6. Disconnect the bobweight actuating rod (24) at the tee bar.
 7. Remove the tunnel plate just aft of the tee bar by laying back enough tunnel carpet to remove the plate attachment screws.
 8. Remove the two aileron control cable pulleys (21) attached to the lower section of the tee bar by removing the pulley attachment bolt (8).
 9. Disconnect the stabilator control cables (23) from the lower end of the tee bar assembly.
 10. Disconnect the necessary control cables, such as the propeller pitch control, mixture control, etc., that will allow the tee bar assembly to be removed.
 11. Remove the tee bar assembly by removing the attachment bolts (3) with washers and nuts which are through each side of the floor tunnel, and lifting it up and out through the right side of the cabin.

5-5. INSTALLATION OF CONTROL COLUMN ASSEMBLY. (Refer to Figure 5-1.)

- a. The tee bar assembly may be installed in the airplane by the following procedure:
 1. Swing the tee bar assembly into place from the right side of the cabin and secure with attachment bolts (3), washers, and nuts inserted in through each side of the floor tunnel.
 2. Connect the bobweight actuating rod (24) to the tee bar. (Refer to Table V-I for proper rigging of bobweight.)
 3. Connect the stabilator control cables (23) to the lower end of the tee bar with bolt (3), washer, nut and cotter pin. Allow the cable ends free to rotate.
 4. Place the aileron control cables (22) around the pulleys (21) that attach to the lower section of the tee bar (7); position pulleys and secure with bolt, washers and nut.
 5. Install the control wheel per Step b.

6. Place the control wheels in neutral (centered) position and install the aileron control chains (14 and 16) on the control wheel sprockets (1 and 13) and idler cross-over sprockets (15 and 18). The turnbuckle (6) must be centered between the two control wheel sprockets.

7. Loosen the connecting bolts (3) of the idler sprockets (15 and 18) to allow the chain to fit snug around the control wheel sprockets and over the idler sprockets.

8. Connect the aileron control cables (22) to the ends of the chains (14 and 16) with bolts, bushings, nuts and cotter pins (19).

9. Adjust the chain turnbuckle (6) between the two control wheel sprockets to allow the control wheels to be neutral and obtain proper cable tension as given in Table V-I. It may be necessary in order to have both control wheels neutral to set the chain turnbuckle to neutralize the wheels and then set cable tension with the turnbuckles located under the floor panel aft of the main spar as instructed in Paragraph 5-11. Before safetying the turnbuckle, check that when the ailerons are neutral, the control wheels will be neutral and the chain turnbuckle centered. Also, the aileron bellcranks should contact their stops before the control wheel hits its stop. Models which have adjustable aileron tee bar stops must maintain .030 to .040 clearance between the sprocket pin and the adjustable stop bolts after the bellcranks contact their stops.

10. Set stabilator cable tension with the turnbuckle in the aft section of the fuselage and instruction given in Paragraph 5-15. Check safety of all turnbuckles upon completion of adjustments.

11. Tighten the connecting bolts (3) of the idler sprockets (15 and 18).

12. Install the floor tunnel plate and secure with screws. Fasten the tunnel carpet in place.

b. Either control wheel assembly may be installed by the following procedure:

1. Insert the control wheel tube through the instrument panel.

2. Should wires for the various Autopilot systems need to be installed in the control tube, route them through the hole in the forward side of the tube and out of the small hole in the side. Position the rubber grommet in the hole in the side of the tube.

3. On the left control tube, install the stop (12).

4. Connect the control wheel tube (4) to the flexible joint (2) of the tee bar assembly. If the control cables and/or chains have not been removed or loosened, place the ailerons in neutral and install the control tube on the flexible joint to allow the control wheel to be neutral. Install bolt, washer and nut (3) and tighten.

5-6. AILERON CONTROLS.

5-7. REMOVAL OF AILERON CONTROL CABLES. (Refer to Figure 5-2.)

a. For the removal of any of the control cables in the fuselage or wings, first remove the floor panel that is located directly aft of the main spar by removing the center seats, seat belt attachments, and the screws securing the panel. Lift the panel and remove from airplane.

b. To remove either the right or left primary control cables (8 and 9) that are located in the fuselage, the following procedure may be used:

1. Remove the tunnel plate just aft of the tee bar by laying back enough tunnel carpet to remove the plate attachment screws.

2. Separate the primary control cable (8 or 9) at the turnbuckles (6) located in the floor opening aft of the main spar.

3. Remove the cable pulleys attached to the lower section of the control column tee bar assembly by removing the pulley attachment bolt.

4. Move the cable guard (see Sketch B) located under the pulley cluster (7) by removing the cotter pin from the exposed end of the guard and sliding it to the left or right as required.

901

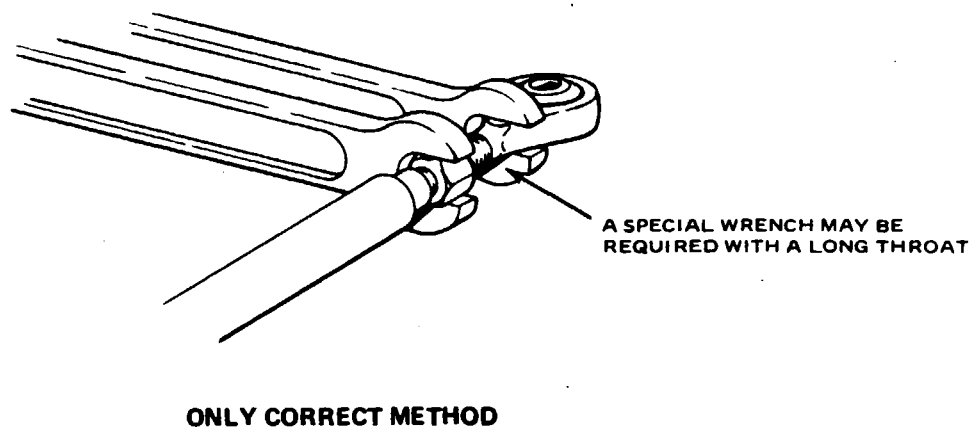
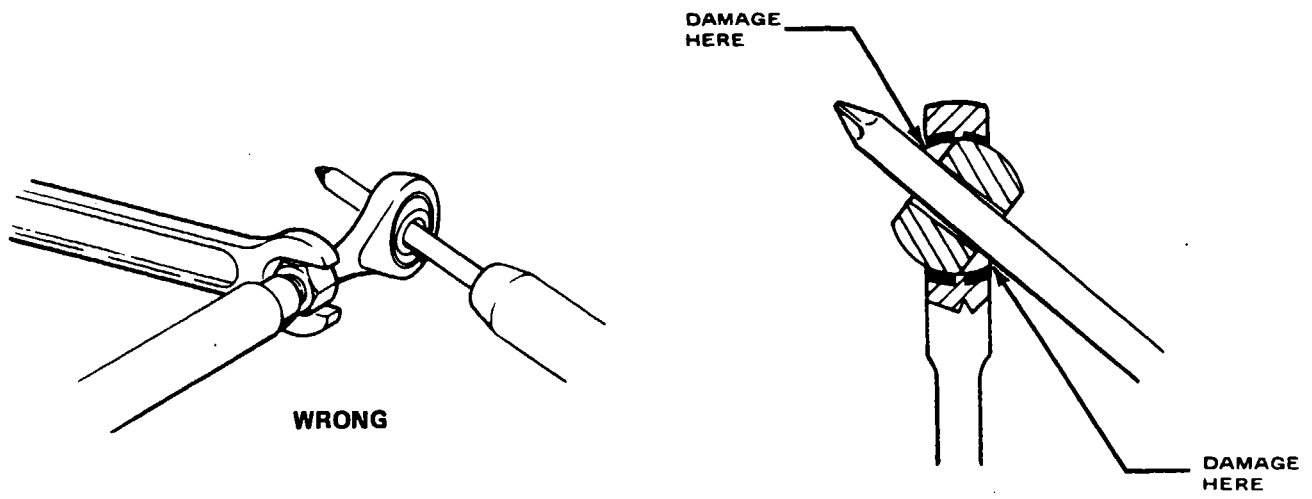

Figure 5-1a. Correct Method of Installing Rod End Bearing

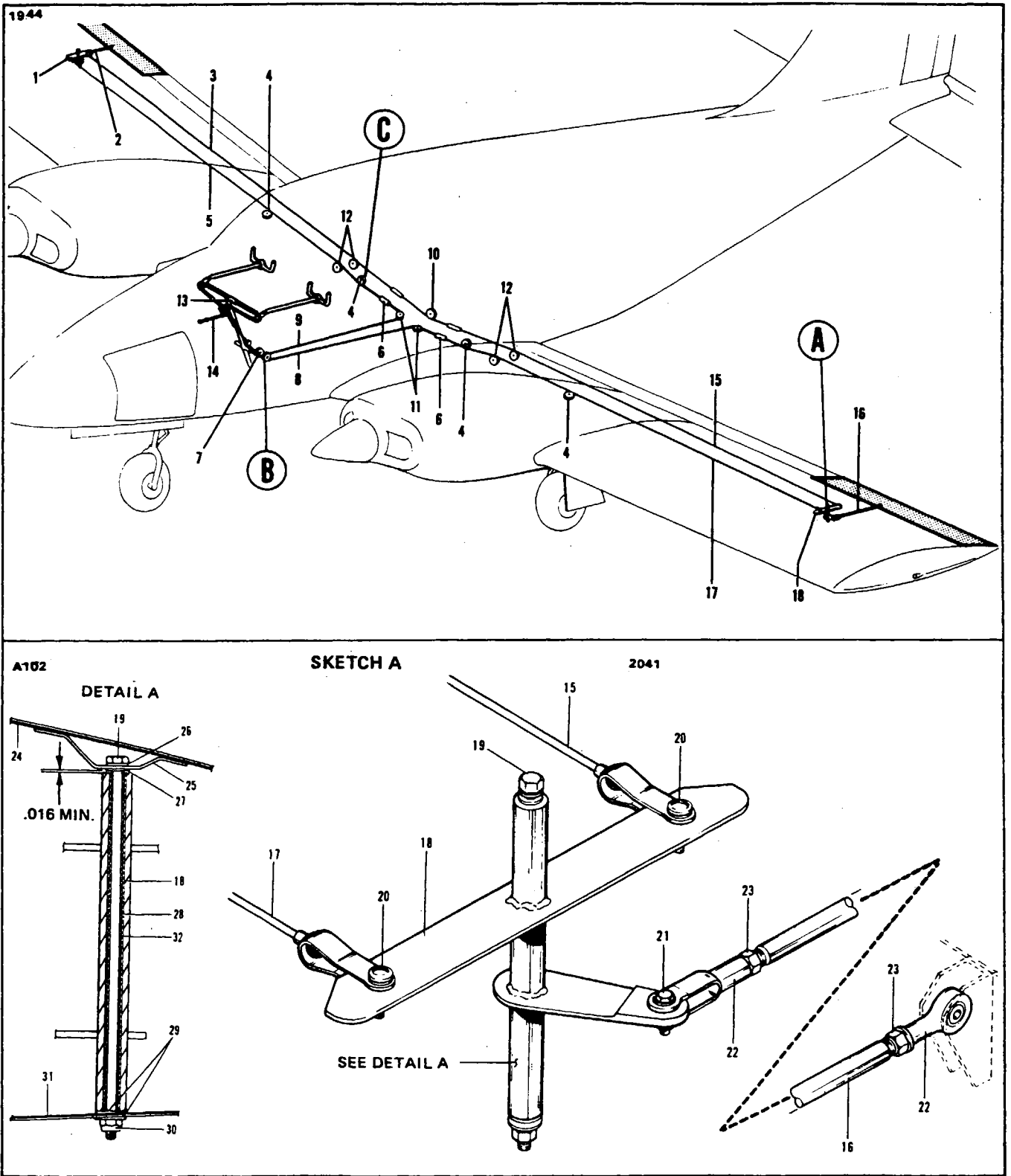

Figure 5-2. Aileron Controls

Reissued: 10/11/79

1G5

SURFACE CONTROLS

PIPER SENECA II SERVICE MANUAL

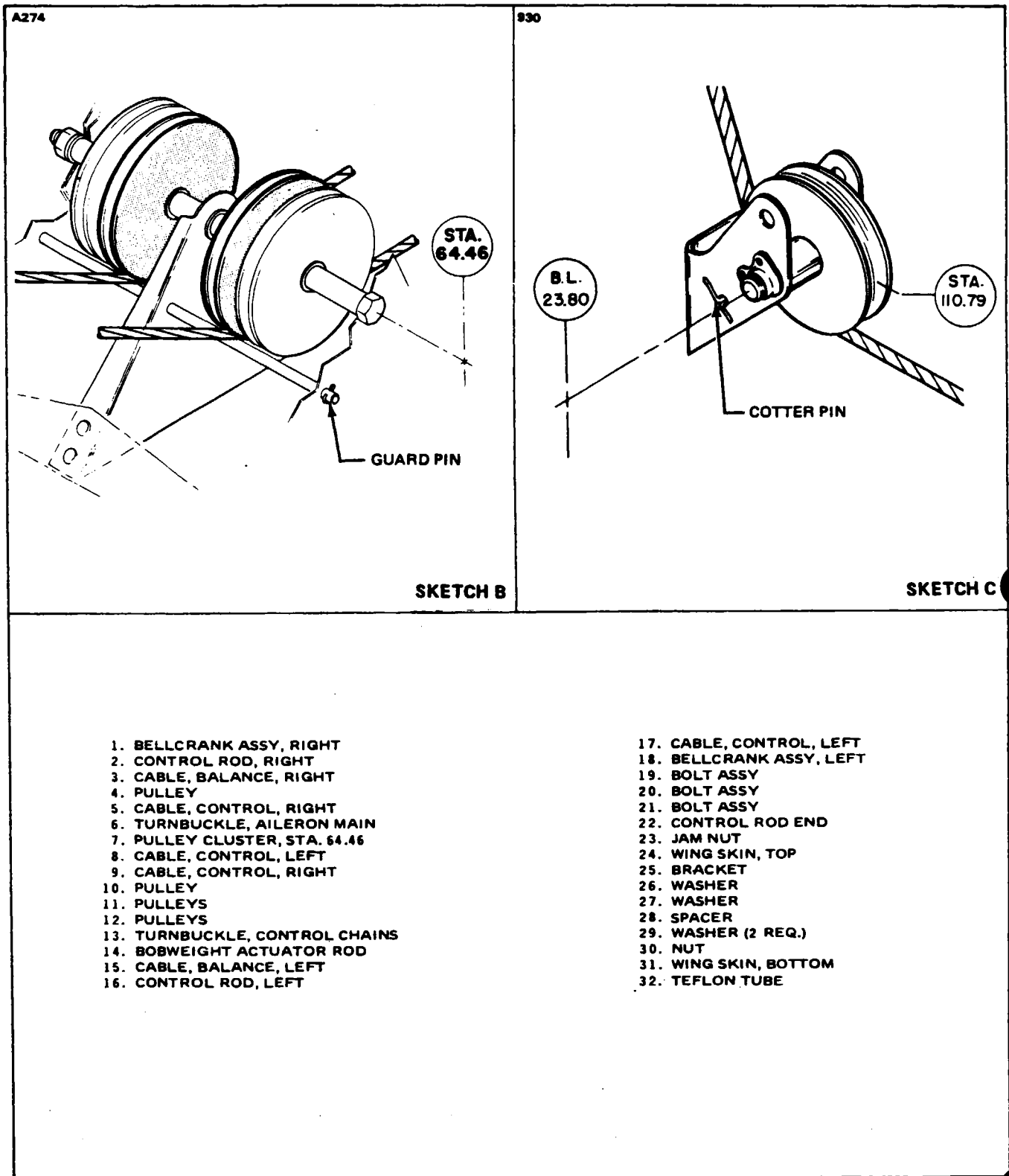

Figure 5-2. Aileron Controls (cont.)

Reissued: 10/11/79

1G6

SURFACE CONTROLS

5. Remove the cotter pins used as cable guards at the pulley (11) in the forward area of the floor opening aft of the main spar.
6. Disconnect the cable (8 or 9) from the control chain at the control column tee bar assembly by removing the cotter pin, nut, bolt, and bushing that connect the two together. Secure the chains in some manner to prevent them from unwrapping from around the sprockets.
7. Draw the cable back through the floor tunnel.
- c. The primary control cable (5 or 17) in either wing may be removed by the following procedure:
 1. Remove the access plate to the aileron bellcrank (1 or 18) located on the underside of the wing forward of the aileron center hinge.
 2. If not previously disconnected, separate the cable at the turnbuckles (6) located in the floor opening aft of the main spar.
 3. Disconnect the cable from the forward end of the aileron bellcrank by removing the cotter pin, nut, washer and bolt.
 4. Draw the cable from the wing.
- d. Either balance cable (3 or 15) may be removed by the following procedure:
 1. Separate the balance cable at the turnbuckle in the right side of the floor opening aft of the main spar.
 2. If the left balance cable is to be removed, remove the cotter pin used as a cable guard at the pulley (10) in the center of the floor opening.
 3. Remove the access plate to the aileron bellcrank (18) located on the underside of the wing forward of the aileron center hinge.
 4. Disconnect the cable from the aft end of the aileron bellcrank by removing the cotter pin, nut, washer and bolt.
 5. Draw the cable from the wing.

5-8. INSTALLATION OF AILERON CONTROL CABLES. (Refer to Figure 5-2.)

- a. The installation of either the right or left primary control cable (8 or 9) that is located in the fuselage may be accomplished as follows:
 1. Draw the cable through the fuselage floor tunnel.
 2. Connect the cable to the end of the control chain and secure using bushing, bolt, nut and cotter pin.
 3. Place the cable around the pulley (see Sketch B) that is located in the tunnel. Install cable guard (see Sketch B) and secure with cotter pin.
 4. Position cables and install the cable pulleys that attach to the lower section of the tee bar assembly. Secure with bolt, washer and nut. (Refer to Figure 5-1.)
 5. Place the cable around the pulley (11) that is located in the floor opening just aft of the main spar and install cotter pin cable guards.
 6. If the primary control cable in the wing is installed, connect the control cable ends at the turnbuckle (6) located in the floor opening aft of the main spar.
 7. Check rigging and adjustment per Paragraph 5-11.
 8. Position the heat duct and secure with screws.
 9. Install the tunnel plate aft of tee bar assembly and secure with screws.
 10. Put the floor carpet in place and secure.
 11. Place the fuel selector lever on the selector torque tube and secure with pin and cotter pin.
 12. Install the lower and upper selector covers and secure with screws.

- b. The primary control cable (5 or 17) in either wing may be installed by the following procedure:
 1. Draw the control cable into the wing.
 2. Connect the cable to the forward end of the aileron bellcrank (1 or 18) using a bolt, washer, nut and cotter pin. Allow the cable end to rotate freely on the bellcrank.
 3. If the primary control cable in the fuselage is installed, connect the ends at the turnbuckle (6) located in the floor opening aft of the main spar.
 4. Check rigging and adjustment per Paragraph 5-11.
 5. Install the access plate on the underside of the wing.
- c. Either balance cable (3 or 15) may be installed by the following procedure:
 1. Draw the cable into the wing.
 2. Connect the cable to the aft end of the aileron bellcrank (1 or 18) using a bolt, washer, nut and cotter pin. Allow the cable end to rotate freely on the bellcrank.
 3. Connect the balance cable ends at the turnbuckle in the floor opening aft of the main spar.
 4. If the left cable was removed, install the cotter pin cable guard at the pulley (10) located in the center of the floor opening.
 5. Check rigging and adjustment per Paragraph 5-11.
 6. Install the access plate on the underside of the wing.
 7. Install the floor panel, seat belt attachments and seats.

5-9. REMOVAL OF AILERON BELLCRANK ASSEMBLY. (Refer to Figure 5-2.)

- a. Remove the floor panel located directly aft of the main spar by removing the center seats, seat belt attachments, and the screws securing the floor panel. Lift the panel and remove from the airplane.
- b. Remove the access plate to the aileron bellcrank (1 or 18) located on the underside of the wing, forward of the aileron center hinge.
- c. Relieve tension from the aileron control cables by loosening the balance cable turnbuckle (6) located in the floor opening aft of the main spar.
- d. Disconnect the primary (5 or 17) and balance (3 or 15) control cables from the bellcrank assembly by removing cotter pins, nuts, washers and bolts.
- e. Disconnect the aileron control rod (16) (Sketch A) at the aft or forward end as desired.
- f. Remove the nut, pivot bolt (19) (Sketch A) and washers that secure the bellcrank. The nut is visible from the underside of the wing.
- g. Remove the bellcrank from within the wing.

5-10. INSTALLATION OF AILERON BELLCRANK ASSEMBLY. (Refer to Figure 5-2.)

- a. Install first the teflon tube (32) then the spacer (28) in the torque tube portion of the bellcrank (18). (See Sketch A.)
- b. Place the bellcrank in position in the wing with a washer located between each end of the torque tube and the mounting brackets.
- c. Install the bellcrank pivot bolt (19) (see Sketch A) with the head up. Install a washer and nut on the bolt and torque nut 20 to 25 inch-pounds. Check that the bellcrank rotates freely with little up-down play. (Refer to Figure 5-2, Sketch A, Detail A.)
- d. Install and adjust control rod (16) (Sketch A) and check aileron travel per Paragraph 5-11.
- e. Connect the ends of the primary (5 or 17) and balance (3 or 15) control cables to the bellcrank using bolts, washers, nuts and cotter pins. Allow the cable ends to rotate freely on the bellcrank.
- f. Tighten the control cables at the balance cable turnbuckle (6) in the floor opening aft of the main spar. Check cable tension per Paragraph 5-11.
- g. Install the access plate on the underside of the wing, the floor panel aft of the main spar, seat belt attachments and seats.

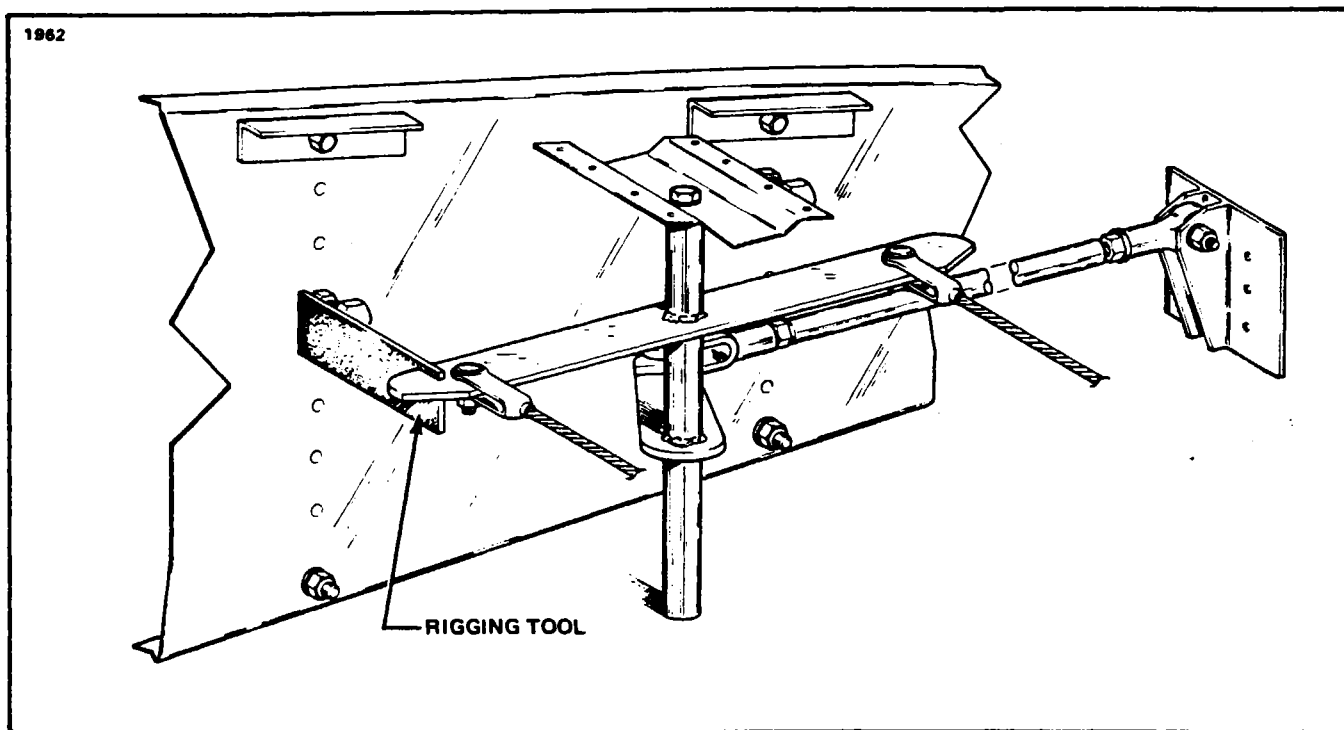

Figure 5-3. Bellcrank Rigging Tool

5-11. RIGGING AND ADJUSTMENT OF AILERON CONTROLS.

PPS500P-2

- a. To check and adjust rigging of aileron controls, use the following procedure:
 1. Ascertain that the control wheels have been properly rigged. (Refer to Paragraph 5-5.)
 2. Place the control wheel in the centered position and place the tee bar in the full forward position. Maintain the wheel and tee bar in these positions. Tee bar may be maintained in the full forward position by placing weights on the aft side of the stabilator if the stabilator cables have been previously tensioned.
 3. Remove aileron bellcrank access plates from the underside of the wings, forward of the aileron center hinge.
 4. Check bellcranks for neutral position. (The neutral position of the bellcrank is the position at which the centerline of the cable connection holes are an equal distance from the adjacent outboard wing rib.) A bellcrank rigging tool can be fabricated from dimensions given in Figure 5-16.
 5. Affix the bellcrank rigging tool as shown in Figure 5-3 between the arm of each bellcrank and the adjacent rib. The slotted end of the tool fits on the arm forward of and adjacent to the primary control cable end. The other end of the tool is positioned so its side contacts the aft side of the bellcrank stop. The bellcrank must be moved to allow a snug fit of the tool between the bellcrank arm and rib. To do so, it may be necessary to loosen a primary control cable or balance cable.
- b. Adjust primary and balance cable tension as given in Table V-1 by the following procedure:
 1. Remove floor panel located directly aft of the main spar by removing the center seats, seat belt attachments and related hardware.
 2. Ascertain that the control wheels are properly rigged (refer to Paragraph 5-5) and both bellcranks are at neutral position.

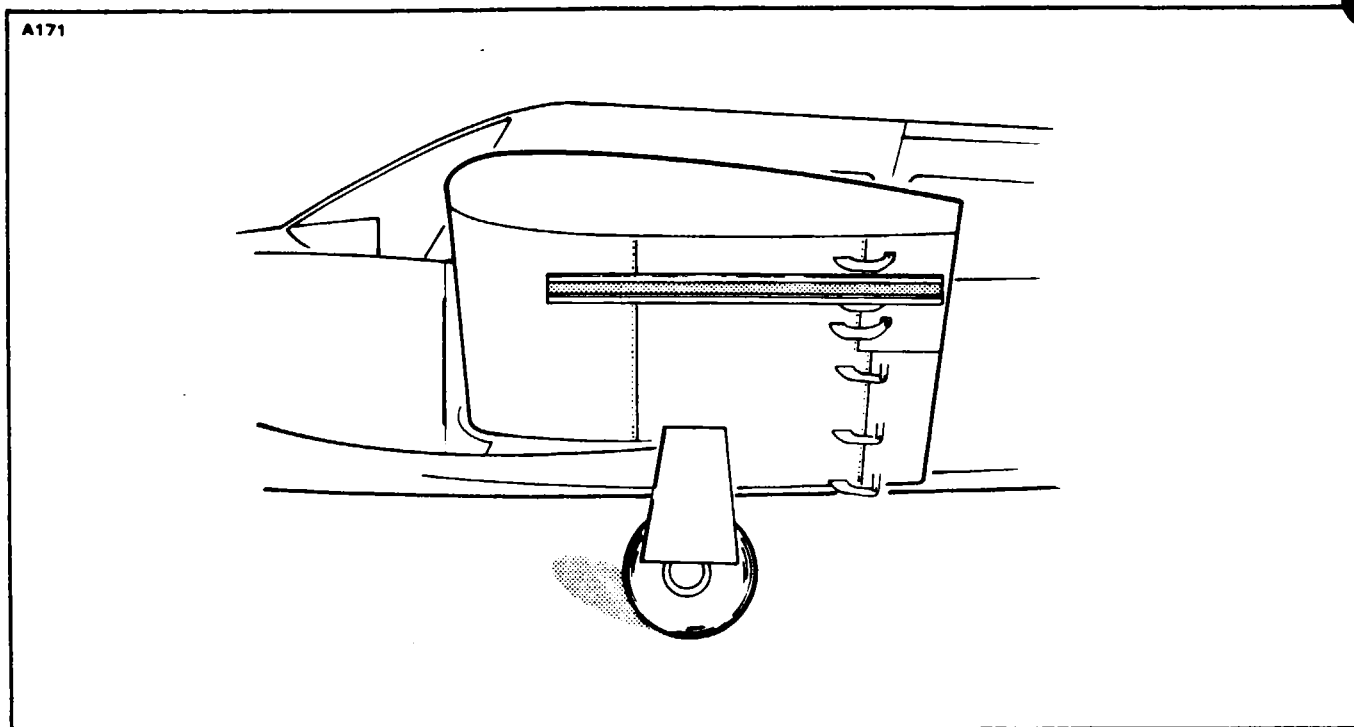

Figure 5-4. Aileron Rigging Tool

3. Adjust the turnbuckles on the primary and balance cables to obtain the proper tension as given in Table V-1. During adjustment, obtain a little more tension on the primary cable to hold the bellcranks in neutral (against the rigging tools); finish with approximately even tension on all cables. Primary cable tensions may be slightly less than balance cable tension, but should be within the tension specified.
4. Remove bellcrank rigging tools.
- c. Check and adjust the aileron for neutral position by the following procedure:
 1. Ascertain that the bellcrank rigging tools fit snug between the bellcrank and the rib.
 2. Check the aileron for neutral. (The neutral position is the position at which the chord line of the aileron forms a $1^{\circ} 12' \pm 1^{\circ}$ "down" angle with the wing chord at the inboard end of the aileron.) An aileron rigging tool can be fabricated from dimensions given in Figure 5-17.
 3. Place the aileron rigging tool as shown in Figure 5-4 against the underside of the wing and aileron as close as possible to the center of the aileron without contacting any rivets. The tool must be positioned parallel with the wing ribs and the aft end of the tool even with the trailing edge of the aileron.
 4. With the aileron control rod connected between the bellcrank and aileron, check that the surface of the wing contacts the tool at its forward surface and at the spacer and the trailing edge of the aileron contacts the aft end of the tool. The aileron is neutral at this position. While measuring the neutral position, a light "up" pressure shall be maintained at the center of the aft edge of the aileron, just sufficient to remove the slack between the bellcrank and the aileron.
 5. Should the three points not contact, loosen the jam nut at the aft end of the control rod and rotate the rod until the three points contact. After adjustment, retighten the jam nut.
- d. Check the ailerons for correct travel from neutral per dimensions given in Table V-1 by the following procedure:
 1. Center the bubble of a protractor over the surface of an aileron at neutral position and note the reading.

2. Move the aileron full up and down and check the degree of travel for each direction. The degree of travel on the protractor is determined by taking the difference between the protractor reading at neutral and up, and neutral and down. The bubble must be centered at each reading.
3. Should the travel not be correct, the travel may be set by rotating the bellcrank stops in or out. Stops are located in the wing attached to the rib that is adjacent to the aileron bellcrank.
4. Repeat this procedure for the other aileron.
5. If the aileron stops are bottomed before the control wheel is turned 90 ± 1 degree from centered position, lengthen the drive cable and shorten the balance cable an equal amount. Recheck cable tension.
 - e. Check the bellcrank stops to assure that the bellcrank contact is made simultaneously but still have cushion before contacting the control wheel stops. Models which have adjustable aileron tee bar stops must maintain .030 to .040 clearance between the sprocket pin and the adjustable stop bolts after the bellcranks contact their stops.
 - f. Check control operation and bolts and turnbuckles for safety.
 - g. Install access plates and panels.

NOTE

When an out-of-trim condition persists despite all the rigging corrections that can be made, there is a possibility that the trailing edge of the aileron has been used to move the aircraft forward. This can result in a slight bulging of the aileron contour at the trailing edge which will cause an out-of-trim condition that is very difficult to correct.

5-12. STABILATOR CONTROLS.

5-13. REMOVAL OF STABILATOR CONTROL CABLES. (Refer to Figure 5-5.)

- a. To remove either the forward or aft stabilator cables, first remove the access panel to the aft section of the fuselage.
- b. Relieve cable tension from control system by loosening one of the cable turnbuckles in the aft section of the fuselage.
- c. Disconnect the stabilator down springs and clamps (18) from the upper stabilator control cable in the aft section of the fuselage.
- d. Either forward stabilator cable (20) may be removed by the following procedure:
 1. Remove the floor tunnel cover in the aft area of the cabin by removing the carpet and the heater duct over the tunnel and the cover attachment screws.
 2. Remove the cable guard plate (see Sketch B) from the underside of the pulley cluster (5) in the aft area of the tunnel opening by removing the guard attachment screws.
 3. Remove the floor panel located directly aft of the main spar by removing the center seats, seat belt attachments, and the screws securing the panel. Lift the panel and remove from the airplane.
 4. Within the floor opening, remove the cable rub blocks (see Sketch A) that are attached to the spar housing by removing the block attachment screws. Also, remove the cotter pin cable guard at the pulley cluster (4) in the aft area of the opening.
 5. Remove the tunnel plate just aft of the tee bar by removing enough carpet from the tunnel to allow the plate attachment screws and plate to be removed.
 6. If the right (upper) stabilator control cable (20) is to be removed, remove the cotter pin cable guards at the pulley (1) located in the forward area of the tunnel.
 7. Disconnect the cables (20) from the lower end of the tee bar by removing cotter pin, nut, washer and bolt.
 8. Draw the cable aft through the floor tunnel.

1G12
INTENTIONALLY LEFT BLANK

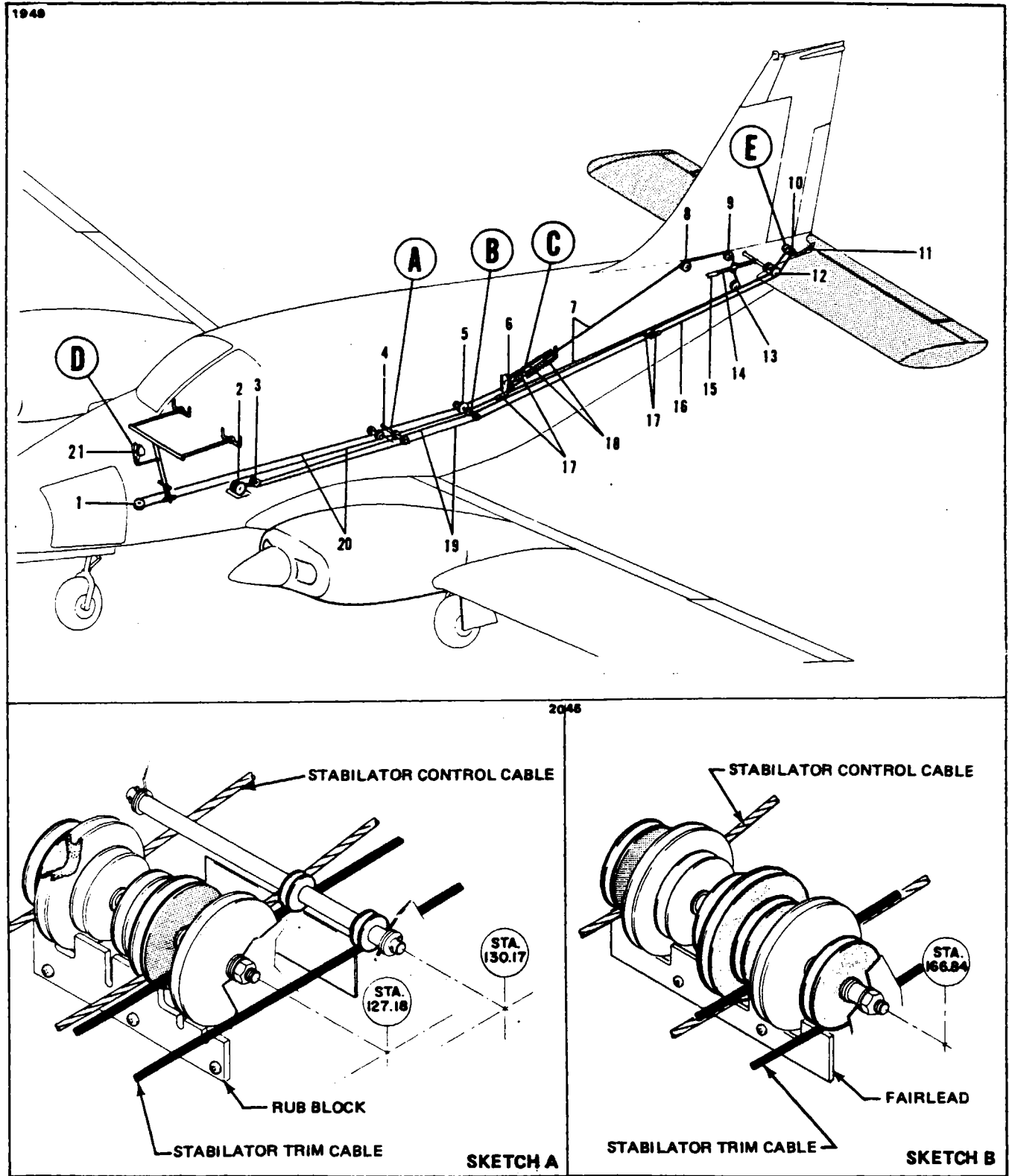

Figure 5-5. Stabilator and Stabilator Trim Controls

Revised: 8/10/80

1G13

SURFACE CONTROLS

PIPER SENECA II SERVICE MANUAL

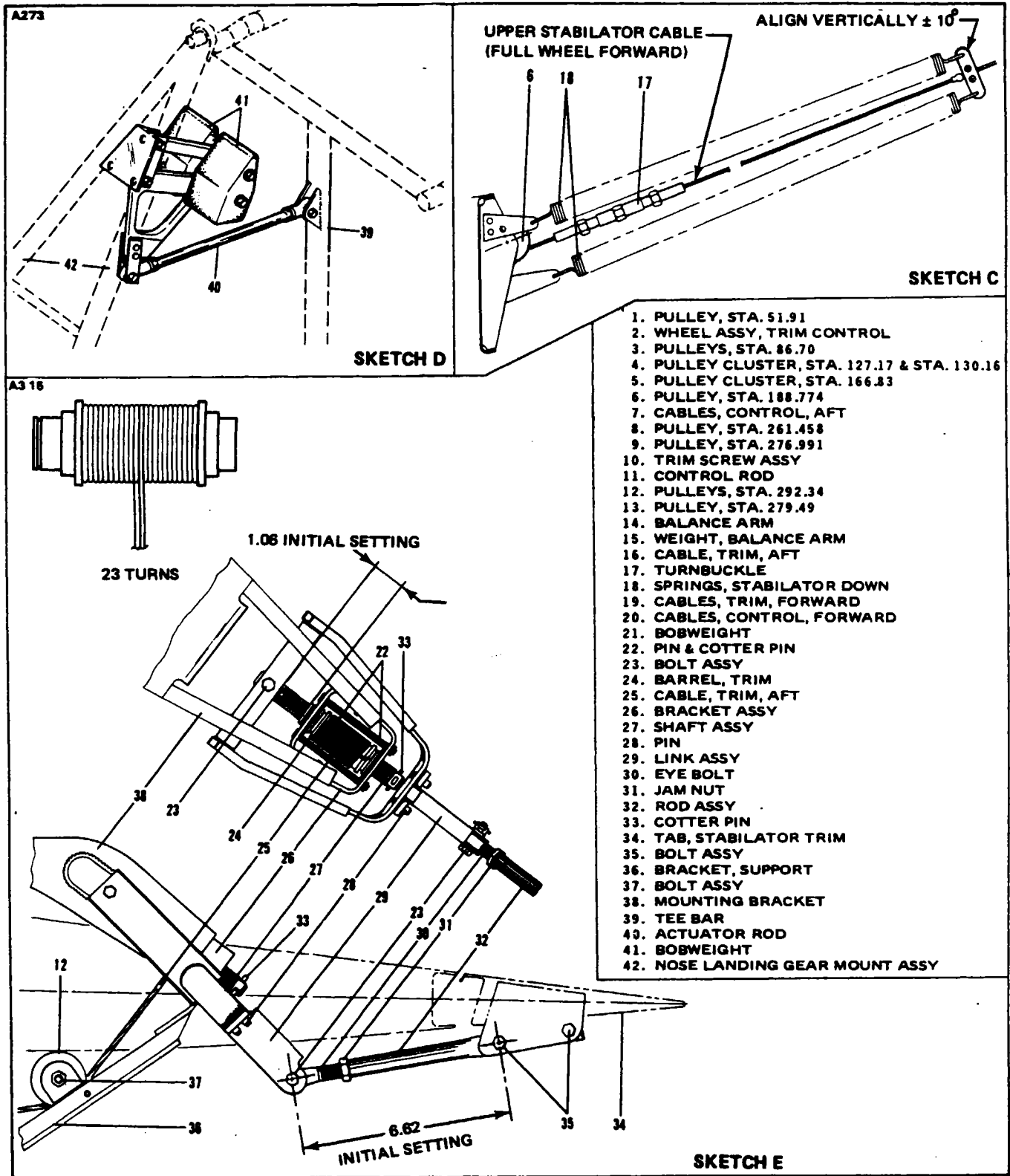

Figure 5-5. Stabilator and Stabilator Trim Controls (cont.)

Revised: 8/10/80

1G14

SURFACE CONTROLS

- e. Either aft stabilator control cable (7) may be removed by the following procedure:
 - 1. Disconnect the cable end at the balance arm (14) of the stabilator by removing the cotter pin, nut, washer and bolt.
 - 2. Remove the cotter pin cable guard at the pulleys (9 or 13) located either above or below the balance arm.
 - 3. Remove the cable from the airplane.

5-14. INSTALLATION OF STABILATOR CONTROL CABLES. (Refer to Figure 5-5.)

- a. The forward stabilator cables (20) may be installed by the following procedure:
 - 1. Draw the control cable through the floor tunnel. Ascertain that the right (upper) cable (20) is routed around the pulley (1) that is in the forward area of the forward floor tunnel.
 - 2. Connect the cables (20) to the lower end of the control column tee bar with bolt, washer, nut and cotter pin. Allow the cable to be free to rotate.
 - 3. If the aft control cable (7) is not installed, install per Step b.
 - 4. Connect the forward control cable to the aft cable at the turnbuckles (17) in the aft section of the fuselage.
 - 5. For the right control cable (20), install the cotter pin cable guard at the pulley (1) in the forward area of the tunnel.
 - 6. Within the forward area of the floor opening aft of the main spar, install the cable rub blocks (see Sketch A) to the spar housing and secure with screws.
 - 7. In the area of the floor opening, install the cotter pin cable at the pulley cluster (4).
 - 8. Install the cable guard plate (see Sketch B) under the pulley cluster (5) located in the aft area of the aft floor tunnel and secure with screws.
 - 9. Set cable tension per Table V-I and check rigging and adjustment per Paragraph 5-15.
 - 10. Connect stabilator down springs and clamps (18) to upper aft stabilator control cable. (See Sketch C.)
 - 11. Install the tunnel plate directly aft of the tee bar assembly and secure with screws.
 - 12. Put the floor carpet in place and secure.
 - 13. Install the floor panel aft of the main spar and secure with screws. Install the seat belt attachments and seats.
 - 14. Install the cover, heat duct, and carpet over the aft floor tunnel.
- b. Either aft stabilator control cable (7) may be installed by the following procedure:
 - 1. Route the cable (7) around its pulley (9 or 13) located either over or under the balance arm (14) of the stabilator.
 - 2. Connect the cable to the stabilator balance arm and secure with bolt, washer, nut and cotter pin. (Insure bushing is installed with bolt.)
 - 3. Connect the aft cable to the forward cable at the turnbuckle (17) in the aft section of the fuselage. The upper aft cable (7) connects to the right forward cable (20) and the lower cable (7) to the left cable (20).
 - 4. Install the cotter pin cable guard at the pulley (9 or 13) where required.
 - 5. Connect the stabilator down spring to the upper aft control cable (see Sketch C).
 - 6. Set cable tension per Table V-I and check rigging and adjustment per Paragraph 5-15.
- c. Install the access panel to the aft section of the fuselage.

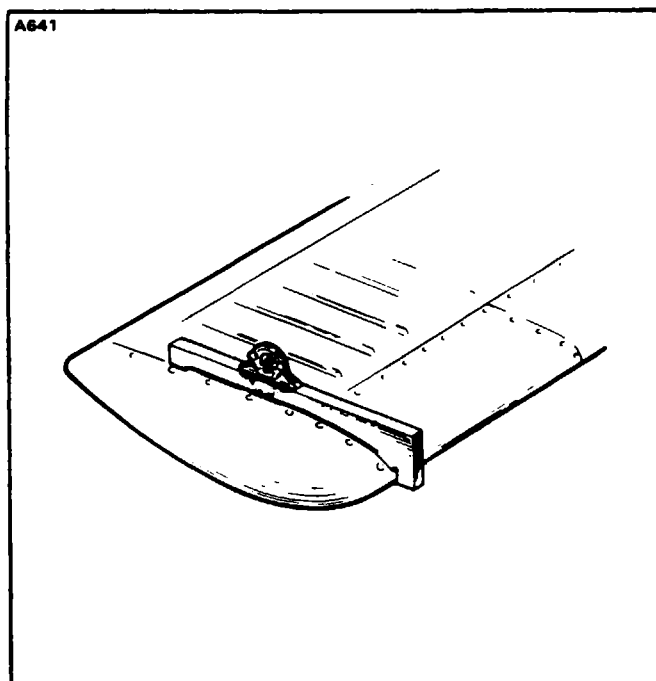

Figure 5-6. Stabilator Rigging Tool

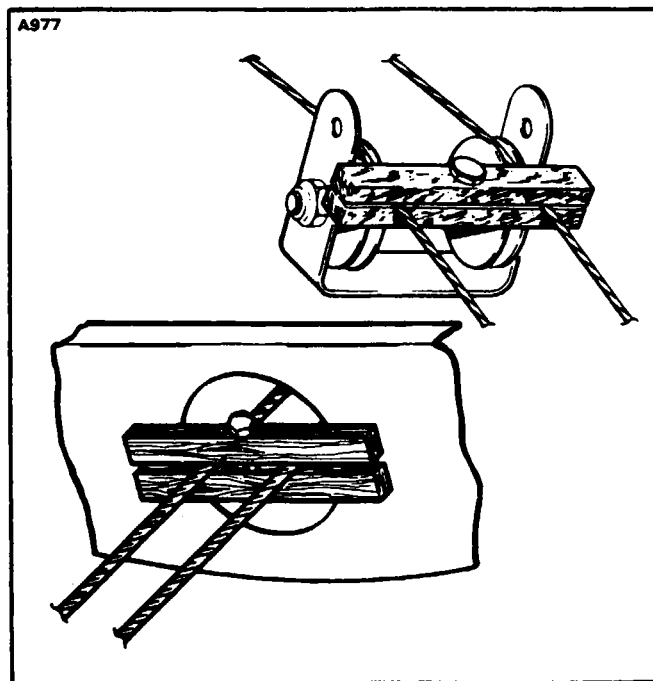

Figure 5-7. Methods of Securing Trim Cables

5-15. RIGGING AND ADJUSTMENT OF STABILATOR CONTROLS.

a. To check and set the correct degree of stabilator bobweight travel, the following procedure should be used:

1. Position the tee bar at a forward angle of seven degrees (neutral position of tee bar).
2. Check the bobweight neutral position (refer to Table V-I).
3. Adjust the bobweight actuating rod between the tee bar and bobweight link to obtain the neutral position.

b. To check and set the correct degree of stabilator travel, the following procedure should be used:

1. Level the airplane. (Refer to Leveling, Section II.)
2. Place the stabilator in its neutral position. (The neutral position of the stabilator is with the stabilator cord line parallel with the top of the front seat track.) A stabilator rigging tool can be fabricated from dimensions given in Figure 5-18.
3. Check the stabilator travel by placing a rigging tool on the upper surface of the stabilator as shown in Figure 5-6.
4. Using a bubble protractor, set the number of degrees up travel as given in Table V-I and place it on the rigging tool. Raise the trailing edge of the stabilator and determine that when the stabilator contacts it stops, the bubble of the protractor is centered.

NOTE

The stabilator should contact both of its stops before the control wheel contacts its stops.

5. Set the protractor for the number of degrees down travel as given in Table V-I and again place it on the rigging tool. Lower the trailing edge of the stabilator and determine that when the stabilator contacts its stops, the bubble of the protractor is centered.

6. Should the stabilator travel be incorrect in either the up or down position, remove the tail cone by removing the attachment screws. Turn the stops located at each stabilator hinge (refer to Figure 5-12) to obtain the correct degree of travel.

7. Ascertain that the locknuts of the stop screws are secure and then reinstall the tail cone.

c. To check and set stabilator control cable tension, the following procedure should be used:

1. Check to insure that the stabilator travel is correct.

2. Remove the access panel to the aft section of the fuselage.

3. Disconnect the down springs.

4. Position the tee bar at a forward angle of seven degrees (neutral position of tee bar) and secure in this position with a suitable tool.

5. Place the stabilator in neutral (refer to Step b) and maintain in that position.

6. Check control cables for the correct tension as given in Table V-I.

7. Should tension be incorrect, loosen the turnbuckles in the aft section of the fuselage and adjust the turnbuckles to obtain the correct tension as stated in Table V-I.

NOTE

Adjust all cables evenly to avoid uneven strain on aircraft components.

8. Check the safety of all turnbuckles and bolts.

9. With the stabilator in neutral, adjust the stabilator tab pushrod to streamline the tab with the stabilator. This is the neutral position of the tab.

10. Check the full travel of the control wheel with relation to the full travel of the stabilator to determine that the stabilator contacts its stops before the control wheel contacts its stops, or the bobweight reaches the limit of its travel.

11. Reconnect the down springs and reinstall the access panels.

12. Refer to Paragraph 5-21 for rigging and adjustment of stabilator trim.

5-16. STABILATOR TRIM CONTROLS.

5-17. REMOVAL OF STABILATOR TRIM ASSEMBLY (FORWARD). (Refer to Figure 5-5.)

a. To remove the trim control wheel assembly and/or the trim control cables, first remove the panel to the aft section of the airplane.

b. If the aft trim cable (16) is not to be removed, block the cables at the pulleys (12) in the tail cone to prevent them from unwrapping from the trim drum. (Refer to Figure 5-7.)

c. Loosen the cables if the trim control wheel is to be removed or disconnected if the cables are also to be removed. Do this at the trim cable turnbuckles (17) in the aft section of the fuselage.

d. The control wheel with drum may be removed by the following procedure:

1. Remove the control wheel cover by removing the cover attaching screws.

2. The wheel assembly may be removed from its mounting brackets by removing nut, washer, and bolt that secures the wheel between the brackets. Draw the wheel from the brackets. Use caution not to damage trim indicator wire.

3. Unwrap the left cable from the drum.

4. The wheel and drum are joined by three screws. Remove screws and separate these two items with their center bushing and unwrap the right cable.

PIPER SENECA II SERVICE MANUAL

5. Tie the cables forward to prevent them from slipping back into the floor tunnel.
- e. The trim control cables (19) may be removed by the following procedure:
 1. Remove the center seats and the pilot and rear seats if desired.
 2. Remove the seat belts attached to the forward floor tunnel by removing attachment nuts, washers and bolts.
 3. Unfasten the carpet from the aft portion of the forward floor tunnel and lay it forward.
 4. Remove the tunnel cover located between the trim control wheel and the spar cover by removing attachment screws.
 5. Remove the cable pulleys (3) located in the forward tunnel by removing the cotter pin, washer and clevis pin.
 6. Remove the floor panel aft of the main spar by removing the panel attachment screws and seat belt attachments. Lift the panel and remove from airplane.
 7. Remove the cable rub blocks (39) located in the floor opening on the aft side of the main spar by removing the block attachment screws.
 8. Remove the carpet and the heater duct over the aft floor tunnel.
 9. Remove the cover plate from the top of the aft floor tunnel by removing attachment screws.
 10. Remove the cable guard (see Sketch A) from the underside of the trim cable pulleys (4) located at station 130.167 by removing the cotter pin and withdrawing the roll pin.
 11. Remove the cable fairlead (see Sketch B) from the underside of the pulley cluster (5) located at station 166.837 by removing the plate attachment screws.
 12. With the cables disconnected from the trim control wheel, draw the cable(s) through the floor tunnel.

5-18. INSTALLATION OF STABILATOR TRIM ASSEMBLY (FORWARD). (Refer to Figure 5-5.)

- a. The trim control wheel with drum may be installed by the following procedure:
 1. Wrap the right trim cable on the trim drum by inserting the swaged ball of the cable in the slot provided in the side (right side) of the drum that mates with the control wheel, and looking at this side, wrap the drum with three and a half wraps of the cable in a clockwise direction.
 2. Attach the control wheel to the cable drum by aligning the long lug of the drum with the long slot of the wheel and securing the two pieces together with three screws.
 3. Wrap the left trim cable on the drum by inserting the swaged ball of the cable in the slot provided in the flanged side (left side) of the drum and looking at this side, wrap the drum with three and a half wraps of the cable in a clockwise direction.
 4. Lubricate and install the bushing in the control wheel and drum.
 5. Align the control cables and position the control wheel assembly between its mounting brackets. Ascertain that the end of the trim indicator wire is positioned in the spiraled slot of the drum with no bind on the end. Install the retainer bolt from the left side and install washer and nut.
 6. Install the cover over the control wheel and secure with screws, unless the control cables have yet to be installed.
- b. The trim control cables (19) may be installed by the following procedure:
 1. Draw the cable(s) through the floor tunnel.
 2. Wrap the cable drum and install the trim control wheel as given in Step a.
 3. Position the cable pulleys (3) on the mounting bracket and install the clevis pin, washer and cotter pin.
 4. Connect the cable (19) to the aft cable (16) at the turnbuckle (17) in the aft section of the fuselage. Install aft cable (16) if not installed.

5. Install the cable fairlead (see Sketch B) at the underside of the pulley cluster (5) located at station 166.837 and secure with screws.
 6. Install the roll pin type cable guard (see Sketch A) at the underside of the pulleys (4) located in the forward area of the aft floor tunnel and secure it with a cotter pin.
 7. Install the cable rub blocks located on the aft side of the main spar housing and secure with screws.
 8. Remove the blocks that secure the aft trim cable and check that the cables are seated on the pulleys.
 9. Set cable tension per Table V-I and check rigging and adjustment per Paragraph 5-21. Safety all turnbuckles.
 10. Install the tunnel cover on the forward tunnel and secure with screws.
 11. Install the carpet over the floor tunnel.
 12. Install the cover over the trim control wheel and secure with screws and special washers.
 13. Install the seat belts removed from the top of the floor tunnel and secure with bolt, washer and nut.
 14. Install the floor panel and seat belt attachments aft of the main spar and secure panel with screws.
 15. Install the aft floor tunnel and secure with screws.
 16. Install the heater duct and carpet over the aft floor tunnel.
- c. Install the panel to the aft section of the airplane and the seats.

5-19. REMOVAL OF STABILATOR TRIM CONTROLS (AFT). (Refer to Figure 5-5.)

- a. Remove the access panel to the aft section of the fuselage.
- b. Block the trim cables (19) at the first set of pulleys (5) forward of the cable turnbuckles (17) in the aft section of the fuselage by a method shown in Figure 5-7.
- c. Remove the tail cone attachment screws and tail cone from the airplane.
- d. Block the cable (16) at the trim barrel (24) to prevent them from unwrapping at the barrel.
- e. Disconnect the cables (16 and 19) at the turnbuckles (17).
- f. Remove the cable guard pins (22) at the trim screw and also at the pulleys (12) located below the trim mechanism at station 292.34.
- g. Remove the bolt assembly (23) which connects the forward end of the trim screw with the link assembly (29).
- h. Unscrew the screw (27) from the trim barrel (24).
- i. Remove the four machine screws securing the two parts of the bracket assembly (26) to the mounting bracket (38).
- j. Separate the two parts of the bracket assembly (26) and remove the trim barrel and cable. Note the amount and placement of washers at each end of the barrel to simplify reassembly.
- k. Remove the barrel and cables from the airplane.

5-20. INSTALLATION OF STABILATOR TRIM CONTROLS (AFT). (Refer to Figure 5-5.)

- a. Wrap the trim barrel (24) by first laying the center (as measured equally from each end to the center of the cable) of the aft trim cable (16) in the slot of the barrel (24). Bring the upper cable through the diagonal slot in the flange at the upper end of the barrel and wrap down in a counterclockwise direction. Bring the lower cable through the diagonal slot in the lower end of the barrel and wrap up in a clockwise direction. Wrap the cable as evenly as possible to obtain 23 wraps on the barrel as viewed from the side opposite the slot and with the cables extending out from the slotted side.
- b. Block both cables by clamping them between two pieces of wood laid next to the wraps to prevent them from unwrapping.
- c. Install the barrel between the two parts of the bracket assembly (26). Be sure to install the washers at both ends of the barrel before installing it in the brackets.
- d. Secure the barrel and bracket assembly (26) to the mounting bracket (38) with the four machine screws.
- e. Install the screw (27) into the barrel (24) with the drilled bolt hole facing towards the front of the airplane.
- f. Position the stabilator and trim tab in a neutral position (refer to Paragraph 5-21) and adjust the trim screw till the bolt hole in the end aligns with the bolt hole in the yoke of the link assembly (29); then install the bolt assembly (23) and secure.
- g. Route the cable (16) around the pulleys at station 292.34 and forward to the turnbuckles (17) in the fuselage.
- h. Ascertain that the cables are in the pulley grooves; then install the guard pins (22) at the pulleys (12).
- i. Connect the cables (16) to the turnbuckles (17) and remove the blocking from both the forward and aft cables.
- j. Set cable tension in accordance with Table V-I and check rigging and adjustment per Paragraph 5-21.
- k. Install the tail cone and secure with screws.
- l. Install the access panel to the aft section of the fuselage.

5-21. RIGGING AND ADJUSTMENT OF STABILATOR TRIM. (Refer to Figure 5-5.)

PPS5009-2

- a. Level the airplane. (Refer to Leveling, Section II.)
- b. Remove the tail cone fairing from the fuselage by removing the attaching screws.
- c. Remove the access panel to the aft section of the fuselage.
- d. Secure the stabilator in its neutral position. To find neutral, place a rigging tool on the upper surface of the stabilator as shown in Figure 5-6. Zero a bubble protractor on the top of the front seat tracks; then set it on the rigging tool and tilt the stabilator until the bubble is centered.
- e. The following items should be accomplished as a preadjustment check before proceeding with the rigging of the trim tab. If these items were accomplished during the installation, proceed with Step f.
 1. Ascertain that the cable is wrapped 23 times around the barrel as shown in Figure 5-5.
 2. The trim screw is adjusted to an initial length of 1.06 inches as shown in Figure 5-5.
 3. The actuating rod is initially adjusted to 6.62 inches in length as shown in Figure 5-5.
 4. Set the trim cable tension in accordance with Table V-I. If the cables were disconnected and replaced, rotate the control wheel several times to allow the cables to seat and then recheck the tension.
- f. Turn the trim control wheel until the trim tab streamlines with the neutral stabilator.
- g. Check the bubble of the protractor over the neutral tab and then check the tab travels as given in Table V-I. The degree of travel on the protractor is determined by taking the difference between the protractor reading at neutral and up, and neutral and down. The bubble must be centered at each reading with the airplane level. Total free travel measured at the tab trailing edge must not exceed .125 inch.

- h. To obtain the correct travels, if incorrect, adjust by disconnecting the link (29) at the rod assembly (32) rod end and turning the end in or out as required. Reconnect the rod end to the link.
- i. Secure the jam nut (31) on the rod assembly.
- j. Turn the trim wheel to full travel and check for turnbuckle clearance and location of tab indicator.
- k. Reinstall the tail cone fairing and aft fuselage access panel.

5-22. RUDDER PEDAL ASSEMBLY.

5-23. REMOVAL OF RUDDER PEDAL ASSEMBLY. (Refer to Figure 5-8.)

- a. Remove the access panel to the aft section of the fuselage.
- b. Relieve rudder and stabilator cable tension by loosening one of the rudder and stabilator cable turnbuckles in the aft section of the fuselage.
- c. Remove the tunnel plate just aft of the tee bar by laying back enough tunnel carpet to remove the plate attachment screws.
- d. Disconnect the stabilator control cable from the lower end of the tee bar assembly and disconnect the bobweight push rod from the tee bar.
- e. Remove the tee bar attachment bolts with their washers and nuts which are through each side of the floor tunnel. Pull the lower end of the tee bar aft.
- f. Disconnect the control cable (22) ends from the arms on the torque tube by removing the cotter pins, washers, nuts and bolts (28).
- g. Disconnect the bungee rods (9) at the control arms by removing nuts and bolts (11).
- h. Disconnect the brake cylinders (5) at the lower end of each cylinder rod (31) by removing the cotter pins and clevis pins (30).
- i. Disconnect the vee brace(s) (4) from the torque tube by removing nuts, washers and bolts (8) that secure the strap bracket (7) to the vee brace.
- j. Disconnect the torque tube support bracket (23) where it attaches to the floor tunnel by removing its attachment bolts.
- k. Remove the two bolts (21) that extend through the torque tube and are located at the center of the tube assembly over the floor tunnel. Compress the tubes.
- l. Disconnect the torque tube support blocks (34 and 35) from the support brackets on each side of the fuselage by removing the attachment nuts, washers and bolts (2).
- m. Remove the trim side panels if desired.
- n. Remove the assembly from the airplane. Note the spacer washer (17) on each end and between the support blocks.

5-24. INSTALLATION OF RUDDER PEDAL ASSEMBLY. (Refer to Figure 5-8.)

- a. Assemble the torque tube assembly as shown in Figure 5-8. Do not at this time install the two bolts through the center of the tube assembly.
- b. Place the upper support blocks (34) on the ends of the torque tube assembly. Note that a washer (17) is required on each end of the tube.
- c. Position the support blocks (34 and 35) on their mounting brackets at each side of the fuselage and secure with bolts, washers and nuts. Note that a bushing is required in the bolt holes of the upper support block, and a plate on top of the upper block, between the upper and lower blocks and under the block mounting bracket.
- d. Align the bolt holes in the center area of the torque tube assembly; install bolts, washers and nuts (21) and tighten.

PIPER SENECA II SERVICE MANUAL

938

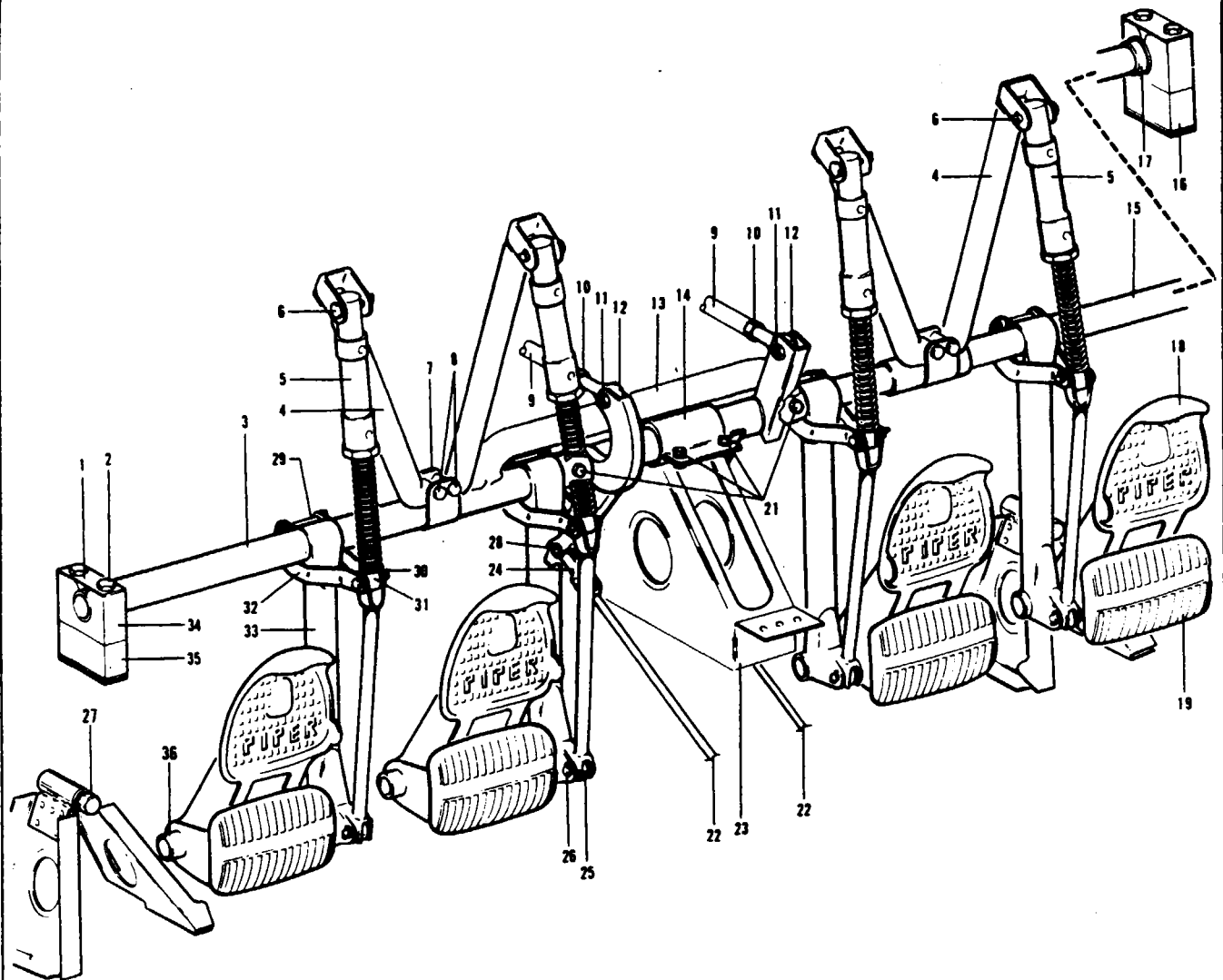

- | | |
|--------------------------------|------------------------------------|
| 1. PLATE | 19. RUDDER PEDAL |
| 2. BOLT & NUT | 20. CLEVIS ROD |
| 3. TUBE, LEFT, OUTER | 21. BOLT, WASHER & NUT |
| 4. VEE BRACE | 22. CONTROL CABLE, RUDDER |
| 5. BRAKE CYLINDER | 23. BRACKET, TUBE SUPPORT |
| 6. CLEVIS PIN & COTTER PIN | 24. CABLE END |
| 7. BRACKET | 25. ROD END |
| 8. BOLT, WASHER & NUT | 26. CLEVIS PIN & COTTER PIN |
| 9. BUNGEE, NOSE WHEEL STEERING | 27. STOPS, RUDDER PEDAL |
| 10. JAM NUT | 28. BOLT, WASHER, NUT & COTTER PIN |
| 11. BOLT & NUT | 29. PIN, WASHER & COTTER PIN |
| 12. ROD END, STEERING | 30. CLEVIS PIN & COTTER PIN |
| 13. TUBE, LEFT, CENTER | 31. ROD, BRAKE CYLINDER |
| 14. BEARING, SUPPORT | 32. IDLER ARM |
| 15. TUBE, RIGHT, OUTER | 33. TUBE, RUDDER CONTROL |
| 16. SUPPORT BLOCK, LOWER | 34. SUPPORT BLOCK, UPPER |
| 17. WASHER, SPACER | 35. SUPPORT BLOCK, LOWER |
| 18. BRAKE PEDAL | 36. TUBE, RUDDER CONTROL |

Figure 5-8. Rudder and Brake Pedal Assembly

- e. Position the torque tube support bracket (23) on the floor tunnel and secure with bolts.
- f. Position the vee brace(s) (4) on the torque tube; install the strap bracket (7) around the torque tube and brace and secure with bolts, washers and nuts (8).
- g. Connect the ends of the brake cylinder rods (31) and clevis rods (20) to the idler arms (32) and secure with clevis and cotter pins (30).
- h. Connect the bungee rods (9) and secure with bolts and nuts (11). Check steering rod adjustment per Alignment of Nose Gear. Section VI.
- i. Connect the rudder trim to the arm of the torque tube and secure with bolt, washer, nut and cotter pin. A thin washer is installed under the nut which is tightened only finger tight.
- j. Connect the ends of the rudder control cables to the arms provided on the torque tube and secure with bolts, washers, nuts and cotter pins (28). Allow the ends free to rotate.
- k. Swing the tee bar into place and secure with attachment bolts, washers and nuts with the bolts inserted in through each side of the floor tunnel.
- l. Connect the stabilator control cables to the lower end of the tee bar with bolt, washer and nut and secure with cotter pin. Allow the cable ends free to rotate. Connect bobweight push rod to tee bar.
- m. Set rudder cable tension and check rigging and adjustment per Paragraph 5-32.
- n. Set stabilator cable tension and check rigging and adjustment per Paragraph 5-15.
- o. Check aileron cable tension.
- p. Check safety of bolt and turnbuckles.
- q. Install the floor tunnel plate and secure with screws. Fasten the tunnel carpet in place.
- r. Install the access to the aft section of the fuselage.

5-25. RUDDER CONTROLS.

5-26. REMOVAL OF RUDDER CONTROL CABLES. (Refer to Figure 5-9.)

- a. To remove either the forward (2) or aft (10) rudder cables, first remove the access panel to the aft section of the fuselage.
- b. Disconnect the desired cable at the turnbuckles (9) in the aft section of the fuselage.
- c. Either forward rudder cable (2) may be removed by the following procedure:
 - 1. Remove the tunnel cover in the aft area of the cabin by removing the carpet, heat duct and the cover attachment screws.
 - 2. Remove the floor panel located directly aft of the main spar by removing the center seats, seat belt attachments and the screws securing the floor panel. Lift and remove the panel from the airplane.
 - 3. Remove the tunnel plate just aft of the tee bar by removing enough carpet from the tunnel to allow the plate attachment screws and the plate to be removed.
 - 4. Remove the cable guard plate (see Sketch C) from the underside of the pulley cluster (8) that is located in the aft area of the floor tunnel, by removing the guard attachment screws.
 - 5. From within the area of the floor opening, remove the cable rub blocks (see Sketch B) that are attached to the spar housing by removing the block attachment screws.
 - 6. Remove the cable guard pin (see Sketch A) located under the pulley cluster (1) by removing the cotter pin from the exposed end and sliding the pin to the left or right as required.
 - 7. Disconnect the end of the cable from the arm on the rudder pedal torque tube by removing the cotter pin, nut, washer and bolt. (Refer to Figure 5-8.)
 - 8. Draw the cable from the floor tunnel.

- d. The aft rudder control cable (10) may be removed by the following procedure:
1. Remove the tail cone by removing its attachment screws.
 2. Disconnect the cable (10) from the rudder sector (13) by removing the two cotter pins at the aft center portion of the sector and moving the swagged ball and cable out of the recessed hole in the sector.
 3. Remove the cable guard pins from the pulley (11) brackets at station 280.091.
 4. Draw the cable from the fuselage.

5-27. INSTALLATION OF RUDDER CONTROL CABLES. (Refer to Figure 5-9.)

- a. The forward rudder control cables (2) may be installed by the following procedure:
1. Draw the control cable through the floor tunnel.
 2. Connect the end of the cable to the arm on the rudder pedal torque tube (refer to Figure 5-8) by installing bolt, washer, nut and cotter pin, allowing the cable end to rotate freely.
 3. Connect the forward control cable (2) to the aft control cable (10) at the turnbuckles (9) in the aft section of the fuselage. If the aft control cables are not installed, install them at this time per instructions in Step b. Ascertain that each cable is in the proper pulley groove.
 4. Move the cable guard (see Sketch A) located in the forward tunnel, under the pulley cluster (1) into position, and secure with cotter pin.
 5. Within the area of the floor opening aft of the main spar, install the cable rub blocks (see Sketch B) onto the spar housing and secure with screws at the pulley cluster (6).
 6. Install the cable guard plate (see Sketch C) under the pulley cluster (8) located in the aft area of the floor tunnel and secure with screws.
 7. Set cable tension as given in Table V-I and check rigging and adjustment per Paragraph 5-28. Safety the turnbuckle.
 8. Install the forward tunnel plate aft of the tee bar and secure with screws.
 9. Put the floor carpet in place and secure.
 10. Install the floor panel and seat belt attachment aft of the main spar, securing the panel with screws and install the seats.
 11. Install the cover and carpet of the aft floor tunnel.
- b. The aft rudder control cable (10) may be installed by the following procedure:
1. Position the control cable in the fuselage with the swaged ball next to the rudder sector (13).
 2. Route the cable ends over the pulleys (11) and install the guard pins in the pulley brackets.
 3. Position the swaged ball of the cable in the recessed hole in the sector (13) and secure in place with two MS24665-283 cotter pins.
 4. Connect the cable ends to the forward control cables (2) at the turnbuckles (9) in the aft section of the fuselage.
 5. Set cable tension as given in Table V-I and check rigging and adjustment per Paragraph 5-28. Safety the turnbuckle.
 6. Install the tail cone and secure with screws.
- c. Install the access panel to the aft section of the fuselage.

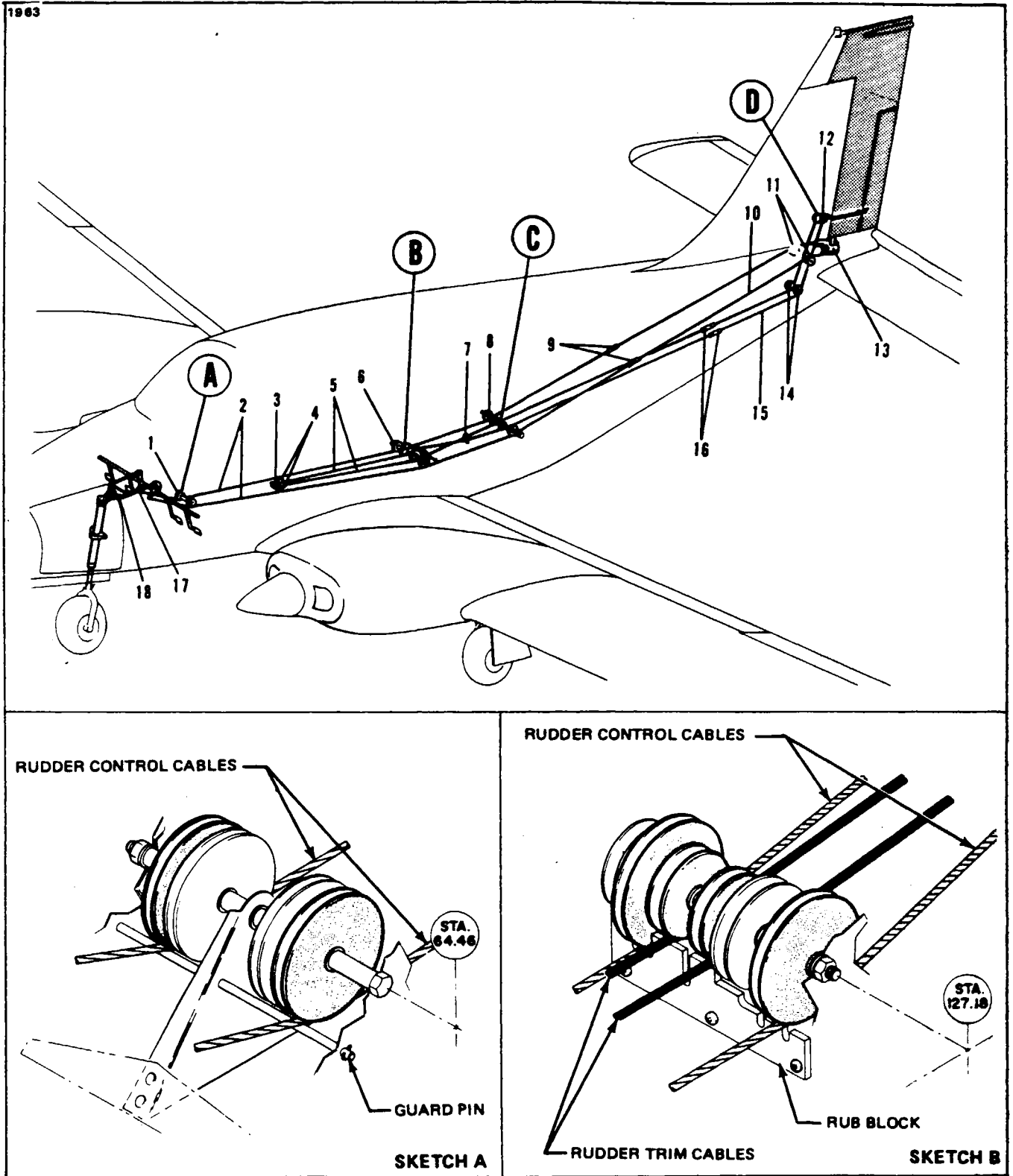

Figure 5-9. Rudder and Rudder Trim Controls

Reissued: 10/11/79

1H1

SURFACE CONTROLS

PIPER SENECA II SERVICE MANUAL

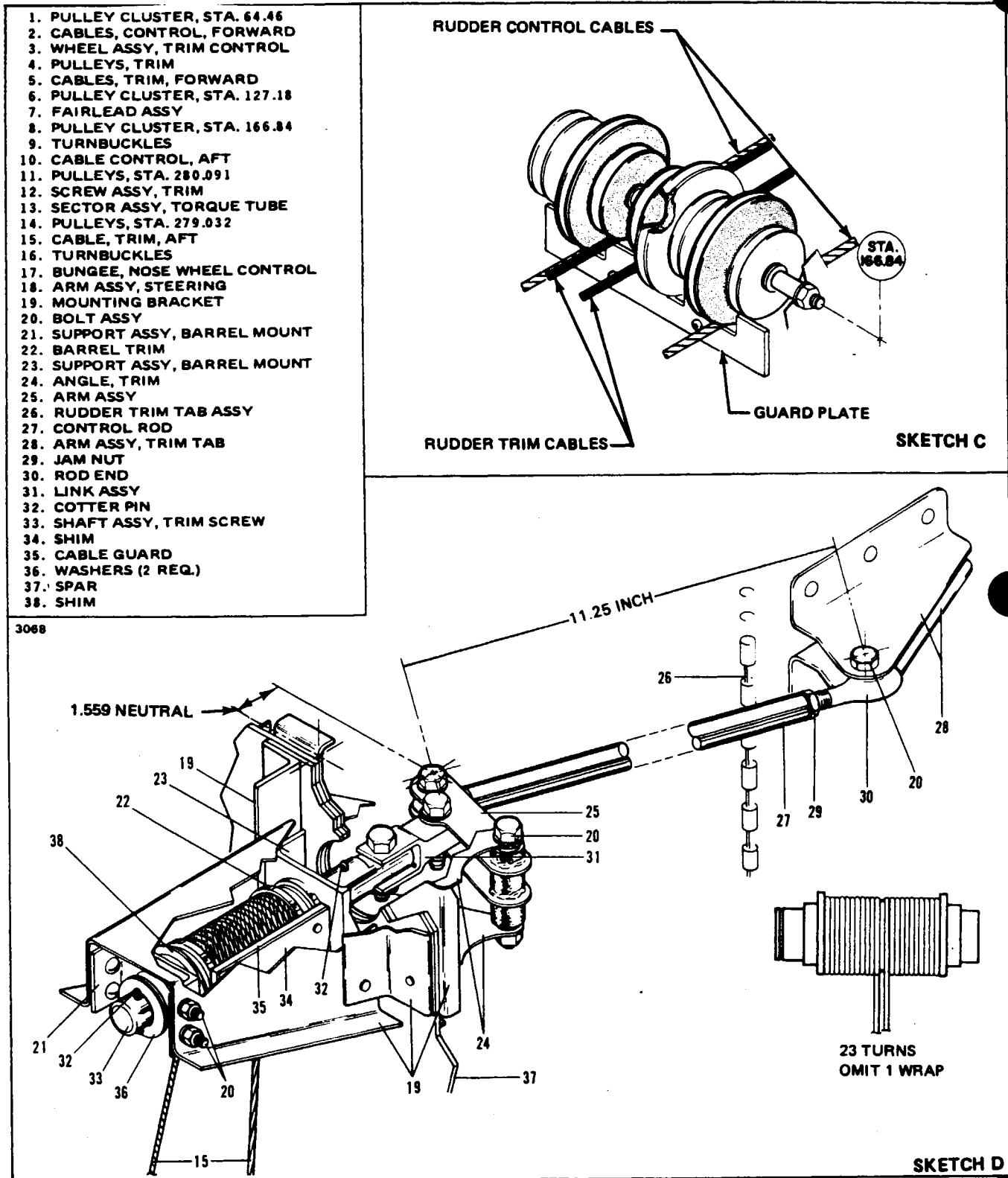

Figure 5-9. Rudder and Rudder trim Controls (cont.)

Revised: 3/16/81

1H2

SURFACE CONTROLS

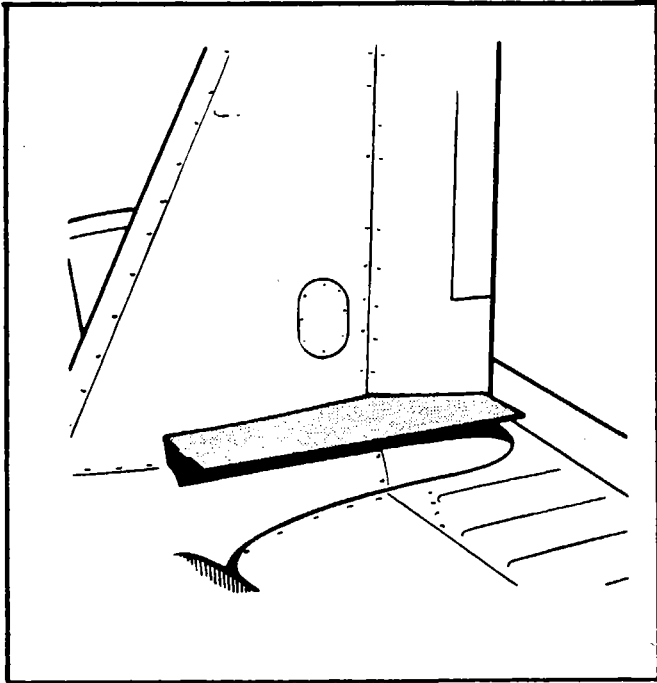

Figure 5-10. Rudder Rigging Tool

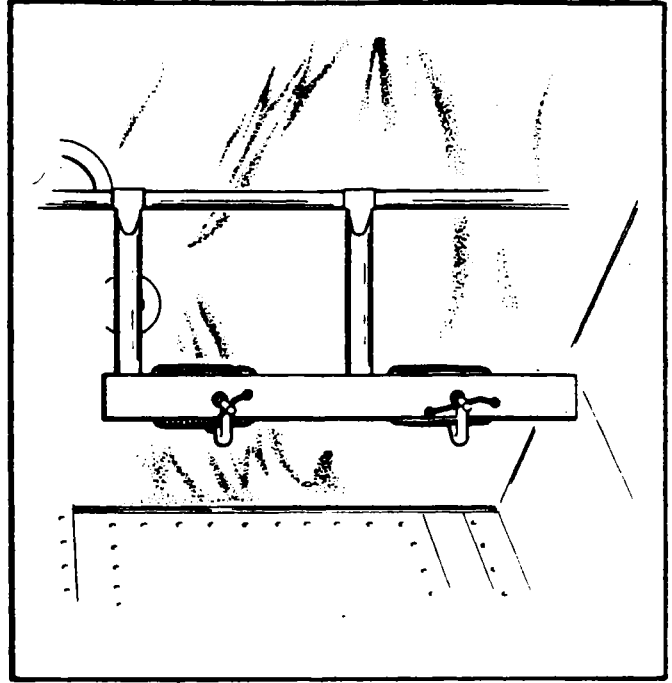

Figure 5-11. Clamping Rudder Pedals

5-28. RIGGING AND ADJUSTMENT OF RUDDER CONTROLS.

PPS5000-2

- a. To check and set the correct degree of rudder travel, the following procedure may be used:
 1. Check the rudder travel by swinging the rudder until it contacts its stop. If the control cables are connected, use the rudder pedals to swing the rudder.
 2. With the rudder against its stop, place a rigging tool against the side of the rudder and vertical stabilizer as shown in Figure 5-10. (Ascertain that the tool is not contacting any rivets.) If no gap exists between the rigging tool and the surface of the rudder and vertical stabilizer, the rudder stop for one direction of travel is correct as required in Table V-I. (This tool may be fabricated from dimensions given in Figure 5-19.)
 3. Swing the rudder in the other direction and check travel as directed in Step 2.
 4. Should the rudder travel be incorrect showing a gap between the tool and any part of the control surfaces, the tail cone should be removed and the stops reset to obtain correct rudder travel. (Refer to Figure 5-12.)
- b. To set cable tension and alignment of the rudder, the following procedure may be used:
 1. Remove the access panel to the aft section of the fuselage.
 2. Streamline the rudder and trim tab with the vertical stabilizer and secure in this position.
 3. Check to insure that the nose gear steering has been aligned and rudder pedals are secured at neutral. (In neutral position the rudder pedals are tilted aft as shown in Figure 7-4 of Section VII.)

NOTE

The nose wheel must be off the ground for remainder of rudder rigging.

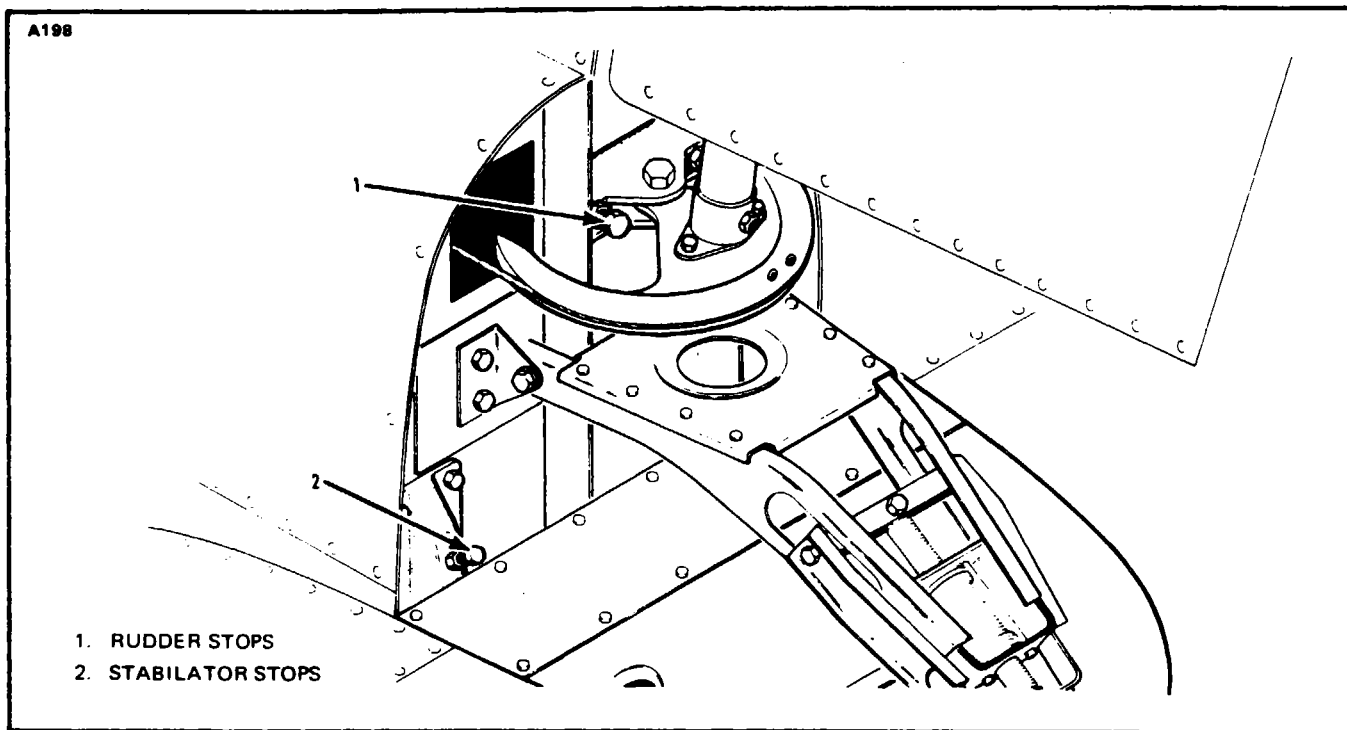

Figure 5-12. Rudder and Stabilator Travel Adjustment

4. Adjust the turnbuckles in the aft section of the fuselage to obtain proper cable tension as given in Table V-1 and to allow the rudder to align at neutral position. Adjust the cables evenly to avoid uneven strain on aircraft components. Neutral position can be determined by standing behind the airplane and sighting the rudder with the vertical stabilizer or the center of the trim screw.

5. Check safety of turnbuckles.

c. With the pilot's left rudder pedal depressed and the rudder against the left stop, adjust the rudder pedal stop to provide .060 to .120 inch clearance. Repeat this procedure with the copilot's right rudder pedal. (Refer to Figure 5-8.)

NOTE

Do not depress the pedals more than is needed for the rudder to contact its stops as the control cables may stretch.

d. Install the tail cone and the access panel to the aft section of the fuselage.

5-29. RUDDER TRIM CONTROLS. (Refer to Figure 5-9.)

5-30. REMOVAL OF RUDDER TRIM CONTROLS (FORWARD). (Refer to Figure 5-9.)

- a. To remove the trim control wheel assembly and/or trim control cables (5), first remove the panel to the aft section of the fuselage.
- b. If the aft trim cable (15) is not being removed, block the cables aft to the turnbuckles (16) to prevent the cables from unwrapping at the trim barrel (22) in the fin. (Refer to Figure 5-7.)
- c. If the trim control wheel is to be removed, loosen the cables at the turnbuckles (16) and proceed with the following steps:
 1. Remove the trim cover assembly by removing the cover attaching screws.
 2. Remove the nut, washers and bolt that secures the trim wheel assembly between its mounting bracket. Draw the wheel from the brackets. Use caution not to damage the trim indicator wire.
 3. Unwrap the lower cable from the drum.
 4. The wheel and drum are joined by three screws. Remove screws and separate these two items and unwrap the upper cable.
 5. Tie the cables forward to prevent them from slipping back into the floor tunnel.
- d. If the trim control wheel and forward cables (5) are to be removed, block the aft cables (15) aft of the turnbuckles (16) and proceed with the following steps:
 1. Remove the tunnel cover in the aft area of the cabin by removing the carpet and heater duct over the tunnel and the cover attachment screws.
 2. Remove the floor panel located directly aft of the main spar by removing the center seats, seat belt attachments and screws securing the panel. Remove the panel from the airplane.
 3. Remove the trim cover assembly to gain access to the trim wheel mounting hardware.
 4. Disconnect the turnbuckles (16) and remove the guard plate (see Sketch C) at pulley cluster (8).
 5. Remove the rub block (see Sketch B) at pulley cluster (6).
 6. Remove the nut, washers, and bolt securing the rudder trim control wheel and drum assembly to its mounting bracket and remove the complete assembly with cables. Use caution not to damage the indicator wire.

5-31. INSTALLATION OF RUDDER TRIM CONTROLS (FORWARD). (Refer to Figure 5-9.)

- a. The trim control wheel with drum may be installed by the following procedure:
 1. Wrap the left cable on the trim drum by inserting the swaged ball of the cable in the slot provided in the upper side of the drum which mates with the control wheel. Looking at this side, proceed to wrap three and a half turns of cable in a clockwise direction.
 2. Attach the trim control wheel to the cable drum by aligning the long lug of the drum with the long slot of the wheel and securing the two pieces together with three screws.
 3. Wrap the right cable on the drum by inserting the swaged ball of the cable into the slot provided in the flanged side (lower) of the drum. Looking at this side, proceed to wrap three and a half turns of cable in a clockwise direction.
 4. Lubricate and install the bushing in the lower side of the drum and the bearing on the upper side of the trim control wheel assembly.
 5. Align the trim control cables (5) and position the control wheel assembly between its mounting brackets. Ascertain that the trim indicator wire is positioned in the spiraled slot of the wheel with no binding on the end. Install the retainer bolt from the upper side, along with the washer and secure with washer and nut from below.
 6. Install the cover assembly over the trim control wheel and secure with screws unless the control cables have yet to be installed.

PIPER SENECA II SERVICE MANUAL

- b. The trim control cables (5) may be installed by the following procedure:
1. Draw the cables (5) through the floor tunnel and route them through the pulley clusters at station 127.17 and 166.84. Ascertain that the cables (5) cross at the fairlead (7) between the two pulley clusters.
 2. Wrap the cable drum and install the trim control wheel as given in Step a.
 3. Position the cables (5) over the proper pulleys (as shown in Sketches B and C of Figure 5-9.)
 4. Connect the forward cables (5) to the aft cables (15) at the turnbuckles (16) in the aft section of the fuselage. If the aft cable is not installed, proceed with instructions given in Paragraph 5-33.
 5. Remove the blocks securing the aft cables and check that the cables (5 and 16) are seated on the pulleys. Install the rub block and guard plate at the appropriate pulley clusters. (Refer to Sketches B and C of Figure 5-9.)
 6. Set trim cable tension in accordance with specifications given in Table V-I and check rigging and adjustment per Paragraph 5-34. Safety both turnbuckles.
 7. Install the tunnel cover on the forward tunnel and secure with screws.
 8. Install the carpet over the floor tunnel.
 9. Install the cover over the trim control wheels and flap handle and secure with screws.
 10. Install the seat belts removed from the top of the floor tunnel and secure with bolt, washer and nut.
 11. Install the aft floor tunnel cover, heater duct and carpet.
 12. Install the carpet over the aft floor plate.
- c. Install the panel to the aft section of the fuselage and the seats.

5-32. REMOVAL OF RUDDER TRIM CONTROLS (AFT). (Refer to Figure 5-9.)

- a. Remove the access panel from the lower side of the fin and the tail cone fairing.
- b. If the forward trim mechanism is not being removed at this time, block the cables forward of the turnbuckles (9) to prevent the cables from unwrapping at the forward trim drum. (Refer to Figure 5-7.)
- c. Secure the trim cables (9) at the aft trim drum barrel (22).
- d. Disconnect the trim cable turnbuckles (9) in the aft section of the fuselage.
- e. Remove the cable guards from the pulley (14) bracket located at station 279.032.
- f. Disconnect the trim screw link assembly (31) from the screw (33).
- g. Remove the cotter pin (32) from the aft end of the screw.
- h. Remove the four bolt assemblies securing the forward support (21) to the mounting bracket.
- i. Remove the screw and barrel assembly (22) along with the aft cables (15) from the airplane.

5-33. INSTALLATION OF RUDDER TRIM CONTROLS (AFT). (Refer to Figure 5-9.)

- a. Insert the complete trim screw and barrel assembly (22) into the fin. Route the trim cable ends around the pulleys at station 279.032.
- b. Insert the trim screw and barrel assembly (22) into the mounting bracket (19). Place the washer on the forward end of the barrel and install the support assembly in the mounting bracket.

NOTE

Total allowable end play of the barrel in the mounting bracket is .006 to .008 inches. Use 62833-18 laminated shim stock washer as required to achieve the correct end play.

- c. Install the AN960-816 and AN960-816L washers over the forward end of the screw shaft and install the cotter pin. Install the cotter pin in the aft end of the shaft.
- d. Adjust the screw assembly to obtain the neutral position. (Refer to Sketch D of Figure 5-9.)
- e. Connect the link assembly (31) to the trim screw.
- f. Connect the aft trim cables to the forward cables with turnbuckles (9). Check to insure the cables are properly routed around the pulleys.
- g. Install the cable guards at the pulley bracket in the fuselage at station 279.032.
- h. Remove the clamp securing the forward trim cables and proceed to rig the system in accordance with Paragraph 5-34.
- i. Lubricate the assembly per Lubrication Chart, Section II.
- j. Install the access panel and tail cone fairing.

5-34. RIGGING AND ADJUSTMENT OF RUDDER TRIM CONTROLS. (Refer to Figure 5-9.)

- a. The following items must be accomplished as a preadjustment check before proceeding with the rigging and adjustment of the tab. If these items were accomplished during the installation, proceed with Step b.
 1. Ascertain that the cable is wrapped 23 turns around the barrel with space at the center as shown in Figure 5-9.
 2. The control rod (27) is adjusted to an initial length of 11.14 inches.
 3. The trim screw (35) is at its neutral position. (Refer to Step d of Paragraph 5-33.)
 4. The cable tension is set in accordance with Table V-I.
 5. The nose wheel is off the ground before continuing.
- b. Remove the access panel on the left side of the vertical fin.
- c. Check the servo travel only by swinging the rudder until it contacts its stops. Use the rudder pedals to swing the rudder in each direction. Refer to Table V-I for proper servo travel.
- d. To adjust the servo travel, the control rod (27) length may be varied. Ascertain that the initial length of the rod (27) was 11.14 inches.
- e. Check the trim only by swinging the rudder until it contacts its stops and turning the trim control wheel to swing the tab to its limits both left and right. Check the travel obtained with specifications given in Table V-I.
- f. To adjust the trim travel left, perform the following:
 1. Add shim washers at the forward end of the barrel to reduce the travel.
 2. Remove shim washers at the forward end of the barrel to increase the travel.
- g. To adjust the trim travel right, perform the following:
 1. Add shim washers at the aft end of the shaft to reduce the trim travel.
 2. Remove shim washers at the aft end of the shaft to increase the trim travel.
- h. Check the trim and servo travels by swinging the rudder full left with full right trim and full right rudder with full left trim.
- i. Check all travels with specifications given in Table V-I.
- j. Determine the free play of the rudder tab with the rudder securely held against either stop. Total free travel measured at the tab trailing edge must not exceed 0.06 inch. If this tolerance is exceeded, check the travel control arm assembly for wear at the center bolt and the bolt attaching the rudder trim rod to the control arm. Replace the arm assembly and associated hardware if there is any noticeable wear or elongation of the holes. Check the rudder trim barrel end play in the mounting bracket. Total allowable play is .006 to .008 inches. Use 62833-18 laminated shim stock washer as required to achieve the correct end play.

5-35. WING FLAP CONTROLS.

5-36. REMOVAL OF WING FLAP CONTROLS. (Refer to Figure 5-13.)

- a. The flap torque tube assembly may be removed by the following procedure:
1. Remove the access plate located between the underside of the aft section of each wing and the fuselage by removing attaching screws.
 2. Remove the floor panel located aft of the main spar by removing the center seats, seat belt attachments and the screws securing the panel. Lift the panel and remove from airplane.
 3. Disconnect the left and right flap control tubes (rods) (13) at the flaps by removing the nuts, washers and bolts (2) or at the torque tube cranks (arms) (17) by removing the bolts and washers (16) from the inner side of each crank. It will be necessary to remove bolt (16) through a hole in the side skin of the fuselage located over the torque tube with the flap handle moved to its 40 degree position.
 4. With the flap handle (30), fully extend the flaps and disconnect the flap tension spring (23) at the spar or the aft end of the control cable (24) as desired.
 5. Grasp the flap handle (30); release the plunger (31) and allow the flap to return to the retracted position. Use caution as forward pressure will be on the handle with the tension spring (23) disconnected.
 6. Disconnect the flap return spring (18) at the spar or return chain (11) as desired.
 7. Disconnect the control cable from the chain (20) by removing cotter pin, nut, and clevis bolt (21).
 8. Remove the tube support bearing blocks (3) by removing the block attachment bolts (7).
 9. Remove the nuts, washers and bolts (7) securing the right and left cranks (17) and stop fittings (14) on the torque tube (8).
 10. From between each wing and the fuselage, remove the cranks (17) from the torque tube.
 11. Disconnect one bearing block (3) from its mounting brackets (4) by removing nuts, washers and bolts (5).
 12. Slide the tube from the bearing block still attached to its brackets; raise the end and lift it from the floor opening.
- b. The flap control cable (24) may be removed by the following procedure:
1. If the center seats and floor panel have not been removed, remove the seats and the screws securing the floor panel.
 2. Disconnect the flap tension spring (23) from the cable (24) if not previously disconnected by extending the flaps to relieve spring tension.
 3. Retract the flap. Use caution as forward pressure will be on the handle with the spring disconnected.
 4. Disconnect the cable from the chain (20) by removing cotter pin, nut, clevis pin and bushing (21).

PIPER SENECA II SERVICE MANUAL

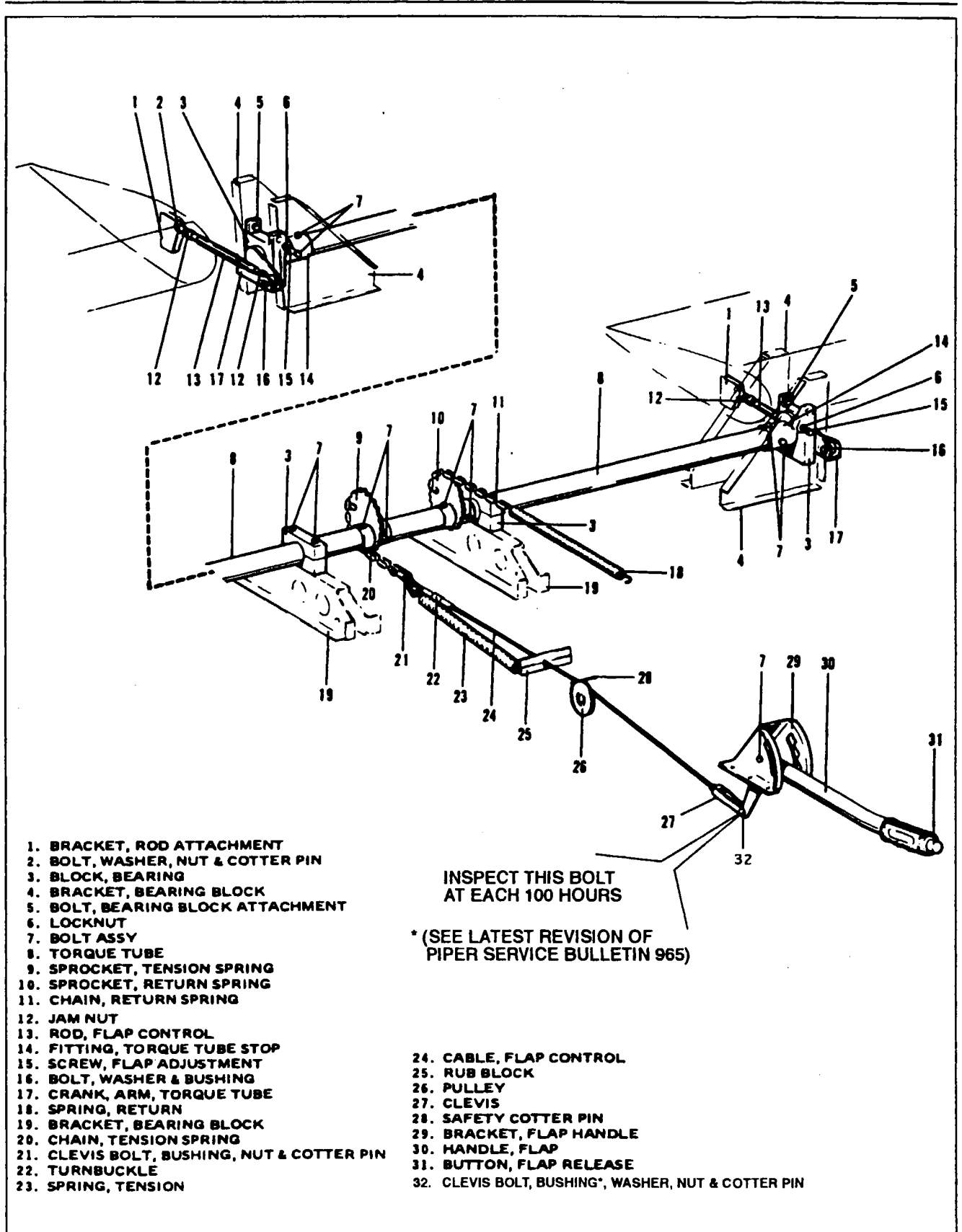

Figure 5-13. Flap Controls

Reissued: 10/11/79

Interim Revision: 02/05/97

SURFACE CONTROLS

1H9

PIPER SENECA II SERVICE MANUAL

5. Remove the flap handle bracket (29) and trim control wheel cover.
 6. Remove the aft heat deflectors on each forward floor tunnel by sliding far enough to release the spring fasteners.
 7. Lift the aft section of the tunnel carpet far enough to remove the screws securing the tunnel cover that is between the flap handle and the spar cover. Remove the cover.
 8. Remove the cotter pin cable guard from the flap cable pulley (26) located inside the floor tunnel just ahead of the spar housing.
 9. Remove the cable rub blocks (25) located in the floor opening on the aft side of the spar housing by removing the attachment screws.
 10. Disconnect the cable turnbuckle (22) at the end of the cable by removing cotter pin, nut and bolt (21).
 11. Disconnect the cable clevis (27) from the flap handle arm by removing cotter pin, nut, washer, bushing*, and bolt (32). Check clevis bolt for wear. Replace bolt if any wear is evident. *(See latest revision of Piper Service Bulletin 965.)
- c. Remove the flap handle (30) and bracket (29) by removing the bolts securing the bracket to the floor tunnel.

5-37. INSTALLATION OF WING FLAP CONTROLS. (Refer to Figure 5-13.)

- a. The flap torque tube assembly may be installed by the following procedure:
 1. Install the chain sprockets (9 and 10) with chains (20 and 11) on the torque tube (8) and secure with bolts, washers and nuts (7).
 2. Slide the tube stop fittings (14) on their respective ends of the torque tube.
 3. Ascertain that one bearing block fitting (3) is installed between its attachment brackets (4).
 4. Slide the other bearing block over its respective end of the torque tube.
 5. Position the torque tube by placing the end with the bearing block on it between the mounting bracket and sliding the other end into the previously attached bearing block.
 6. Position the remaining bearing block and secure with bolts, washers and nuts (5).
 7. Push the torque tube cranks (arms) (17) on each end of the torque tube and slide the stop fitting (14) in place. Align the bolt hole of the crank and stop fitting with the holes in the torque tube and install bolts. The holes in the stop fitting are elongated to allow the stop fitting to be pushed against the bearing blocks (3) thus allowing no side play of the assembly. Tighten the bolt assemblies (7) on the stop fittings.
 8. Install the tube support blocks (3) on their support brackets (19) and secure with bolts (7).
 9. Connect the flap return spring (18) to the return chain (11) and/or at the spar housing.
 10. Connect the control cable end to the tension chain (20) and secure with bushing, clevis bolt, nut and cotter pin.
 11. Pull the flap handle full back and connect the tension spring (23). Release the flap handle to the forward position. (Rig flap cable in accordance with step c.)
 12. Connect the flap control tube (13) to the flap and/or torque tube crank (17) and secure. The bolt (16) and bushing that connects the control tube to the crank is installed through a hole in the side of the fuselage located over the torque tube.
- b. To install the flap handle (30) with bracket (29), place the assembly on the floor tunnel and secure with bolts.
- c. The flap control cable (24) may be installed by the following procedure:
 1. Attach the cable (24) and turnbuckle (22) to the chain (20) with clevis bolt assembly (21). Ascertain that the turnbuckle end is free to rotate on the chain. If the chain is not installed because of the torque tube assembly being removed, install the assembly in accordance with instructions given in Step a.
 2. Route the cable through the tunnel and spar housing.
 3. Install the cable rub blocks (25) on the aft side of the spar housing and secure with screws.
 4. Install cotter pin cable guard over pulley (24) located just ahead of the spar housing in the forward floor tunnel.

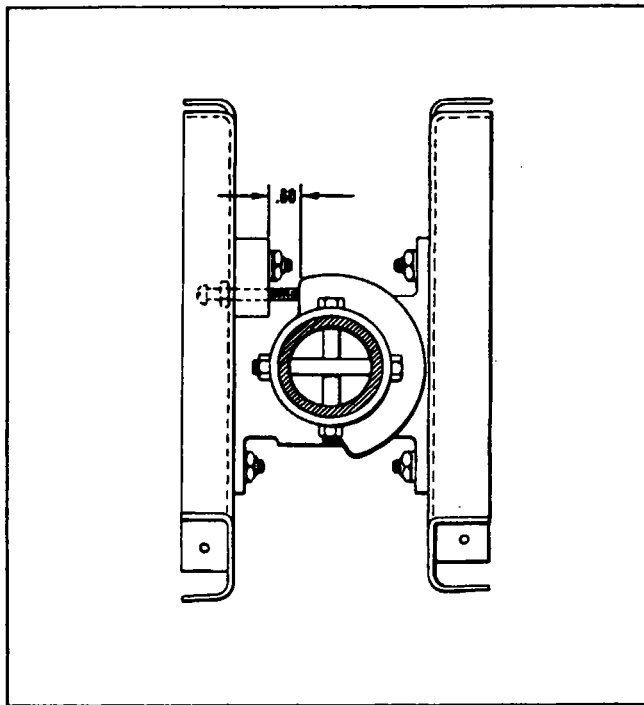

Figure 5-14. Flap Step Adjustment

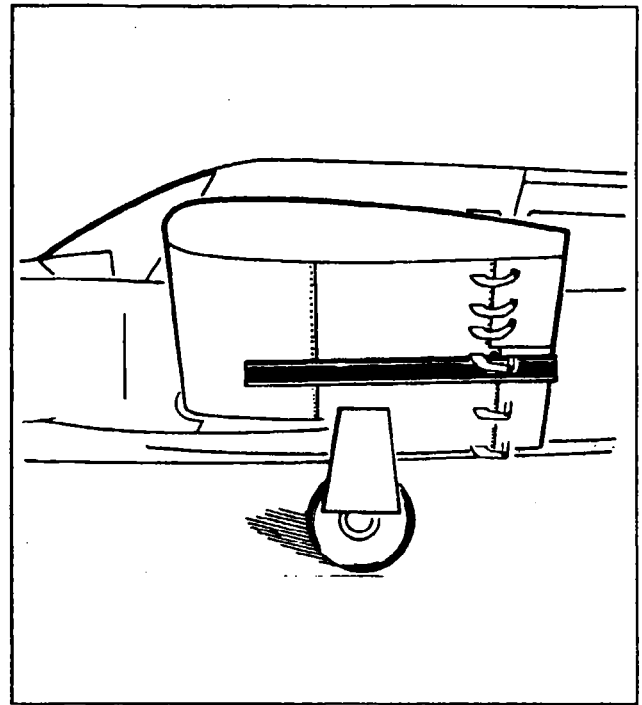

Figure 5-15. Flap Rigging Tool

5. Attach the end of the cable (24) to the flap handle arm and secure with clevis bolt, bushing*, washer, nut, and cotter pin (32). *(See latest revision of Piper Service Bulletin 965.)
6. Adjust cable tension with handle in the FLAPS UP position. (Refer to Table V-I.)
7. Pull the flap handle (30) full back and connect the tension spring (23) to the cable end.
- d. Install the tunnel cover and secure with screws. Also, the tunnel carpet and bracket cover.
- e. Install the floor panel and seat belt attachments. Secure with screws and install seats.

5-38. RIGGING AND ADJUSTMENT OF WING FLAPS.

- a. Place the flap handle in the full forward position.
- b. If not previously removed, remove the floor panel just aft of the main spar.
- c. To adjust the flap up stop and step lock, loosen the jam nut of the right torque tube stop screw, located in the floor opening along the outer end of the flap torque tube, and turn the stop screw to obtain approximately 0.60 of an inch between the stop fitting and the bearing block as measured along the top side of the screw. (Refer to Figure 5-14.) It may be necessary to loosen the adjustment screw of the left stop.
- d. Place a 0.125 spacer between the stop fitting and the end of the screw. Determine that when pressure is applied down on the flap, it will remain in the uplock position. If it extends, turn the adjustment screw out a few threads at a time until the flap remains in the uplock position with the spacer inserted. Tighten the jam nut and remove spacer.
- e. Rotate the left stop adjustment screw until it contacts the stop fitting. Tighten the jam nut.
- f. Set the flap control cable tension (handle next to floor, 0 degrees) as given in Table V-I at the turnbuckle that is attached to the lower end of the flap handle in the floor tunnel. To do this and if not previously removed, remove the flap handle cover and enough tunnel carpet to remove the tunnel cover just aft of the handle. Adjust and resafety the turnbuckle.

NOTE

Do not rotate the torque tube while retensioning the cable or tighten tight enough to allow tube to be pulled away from its stops.

g. To check up-neutral position of the flaps, place a flap rigging tool as shown in Figure 5-15 against the underside of the wing and flap as close as possible to the outboard end of the flap without contacting any rivets. The tool must be positioned parallel with the wing ribs with the aft end of the tool even with the trailing edge of the flap. (This tool may be fabricated from dimensions given in Figure 5-17.)

h. With the flap control rod connected between the torque tube crank arm and the flap, check that the surface of the wing contacts the tool at its forward surface and at the spacer, and the aft end of the flap contacts the aft end of the tool. The flap is neutral at this position.

i. Should the three points not contact, loosen the jam nuts on each end of the control rod and rotate the rod until the three points contact. Apply a slight up pressure (enough to take slack out of linkage) against the trailing edge of the flap while making this adjustment. After adjustment, retighten the jam nuts.

j. Check and adjust the other flap in a like manner.

NOTE

In the event of wing heaviness during flight, the flap on the side of the heavy wing can be adjusted down from neutral to remedy this condition by lengthening the control rod. Check the inspection hole in each rod end to ascertain that there are sufficient threads remaining and a wire cannot be inserted through these holes. Do not raise the flap of the other wing above neutral.

k. Check the flap for full down travel to the degrees required in Table V-I. Should the travel not be as that required, readjust the torque tube stop screw in or out as required. After readjusting the screw, it will be necessary to review Steps d thru j.

l. Check operation of the flap and flap handle ratchet mechanism.

m. Install access plates and panels.

A291

MATERIAL:
.125 X 3.750 X 1.0 ALUM. PLATE

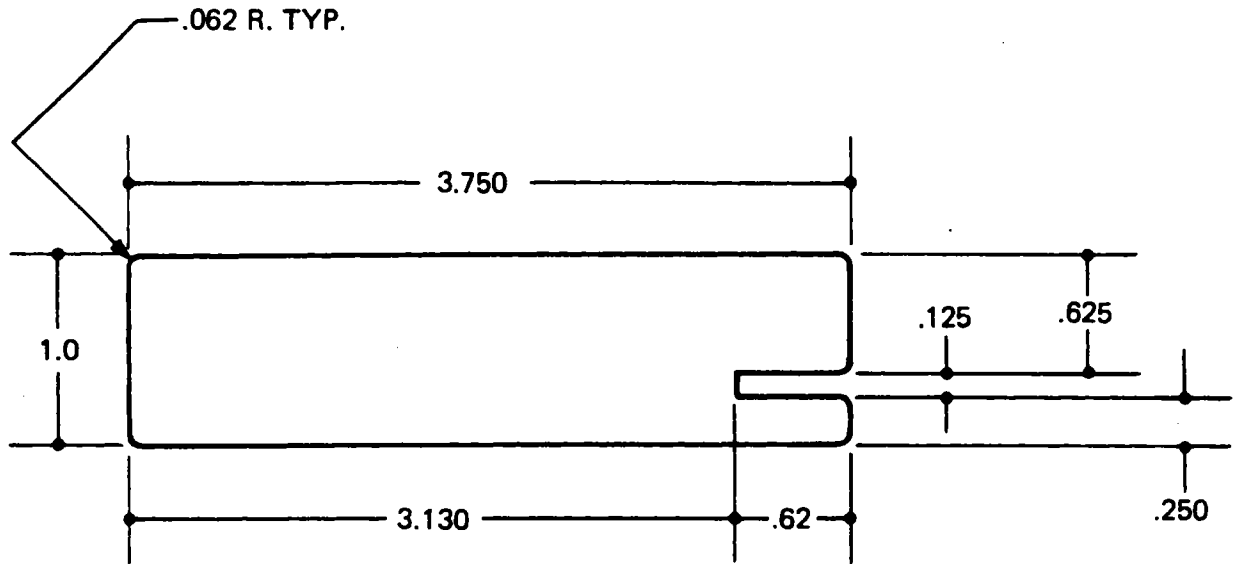

Figure 5-16. Fabricated Aileron Bellcrank Rigging Tool

Reissued: 10/11/79

1H13

SURFACE CONTROLS

PIPER SENECA II SERVICE MANUAL

MATERIAL:
.750 X 31.50 X 4.00 ALUM. BAR

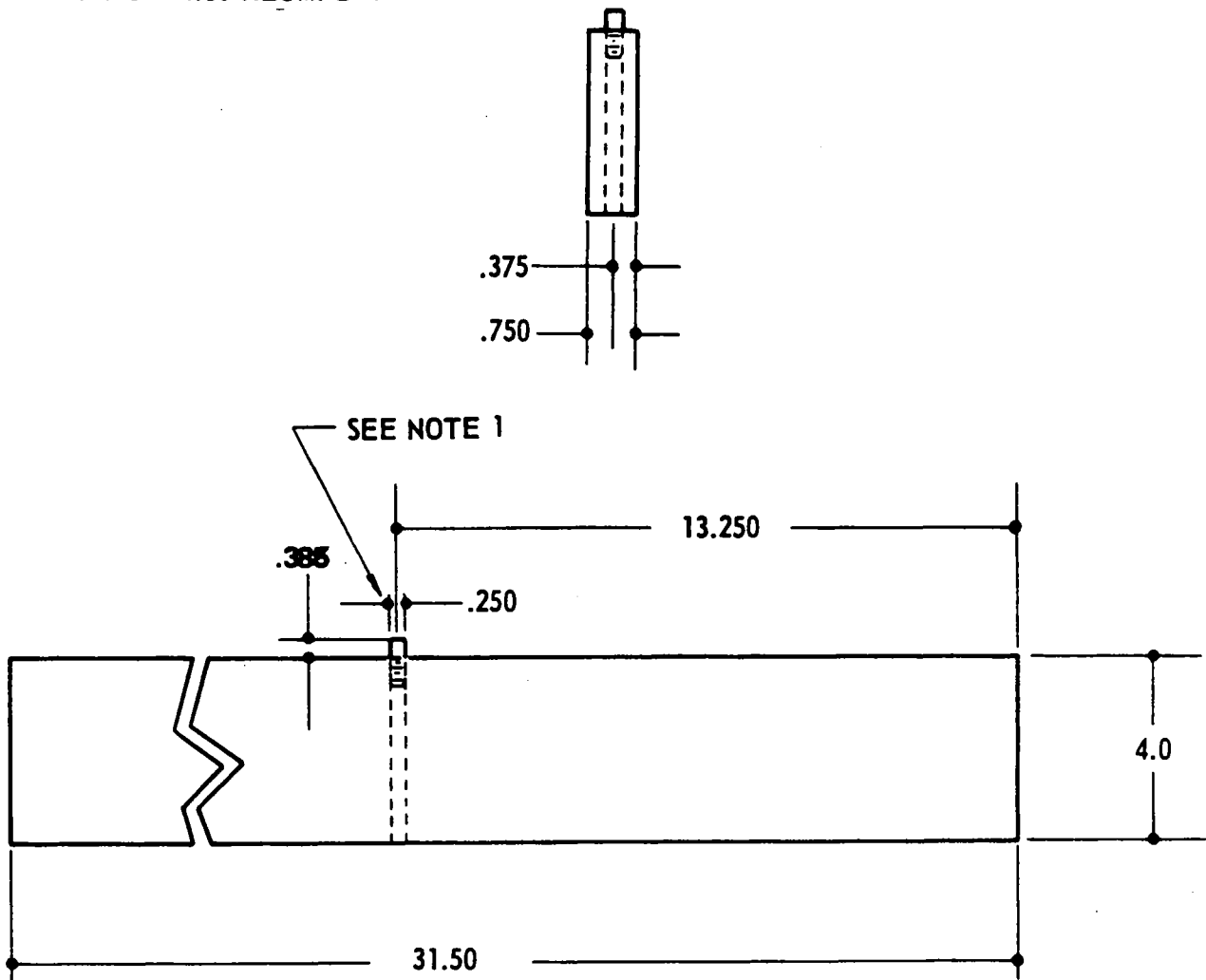

NOTE:

1. DRILL AND TAP TO 1/4 - 28 NF. BOLT AND FILE TO REQUIRED LENGTH.

Figure 5-17. Fabricated Aileron and Flap Rigging Tool

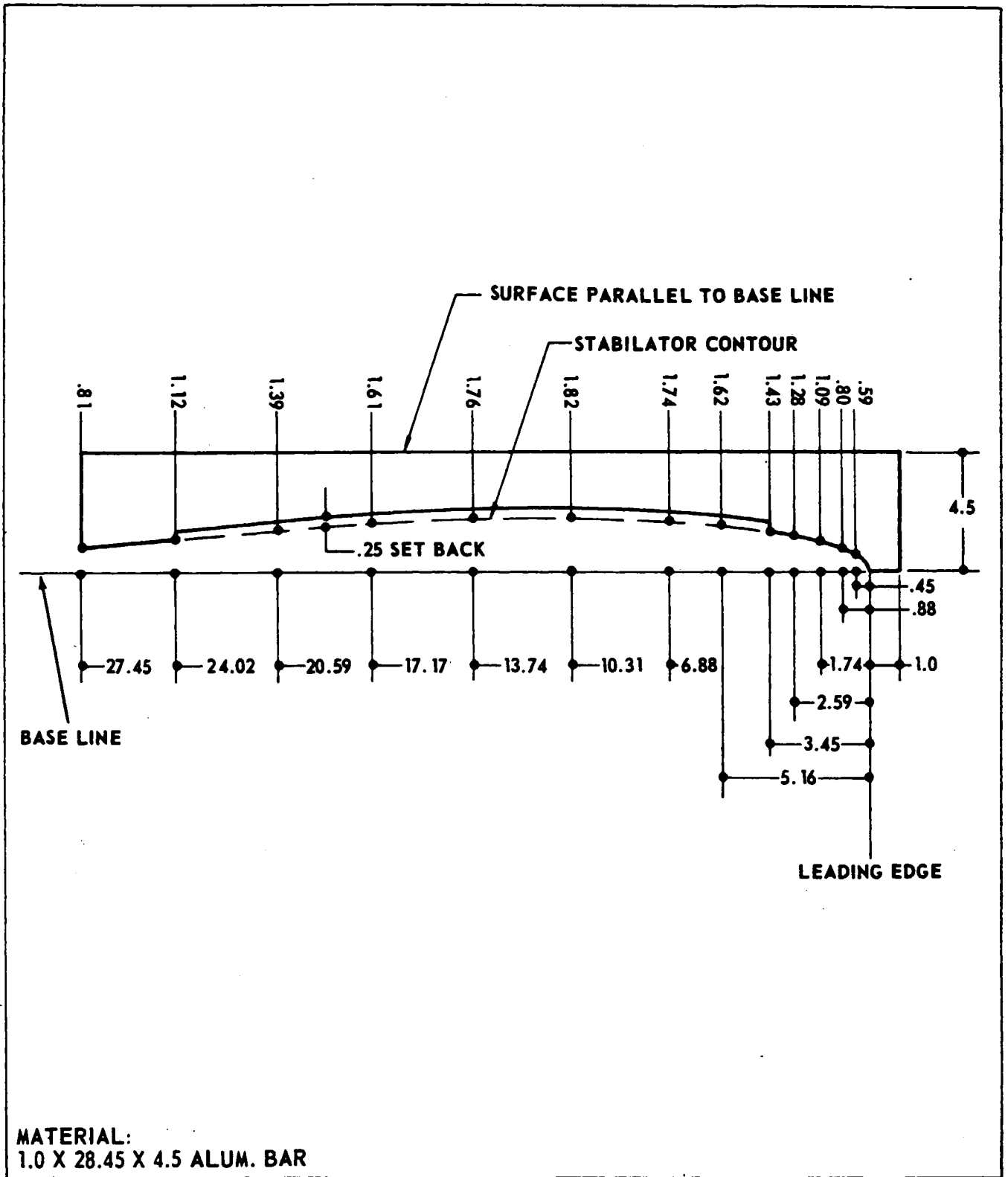

Figure 5-18. Fabricated Stabilator Rigging Tool

Reissued: 10/11/79

1H15

SURFACE CONTROLS

**MATERIAL:
STEEL OR HARD ALUM.**

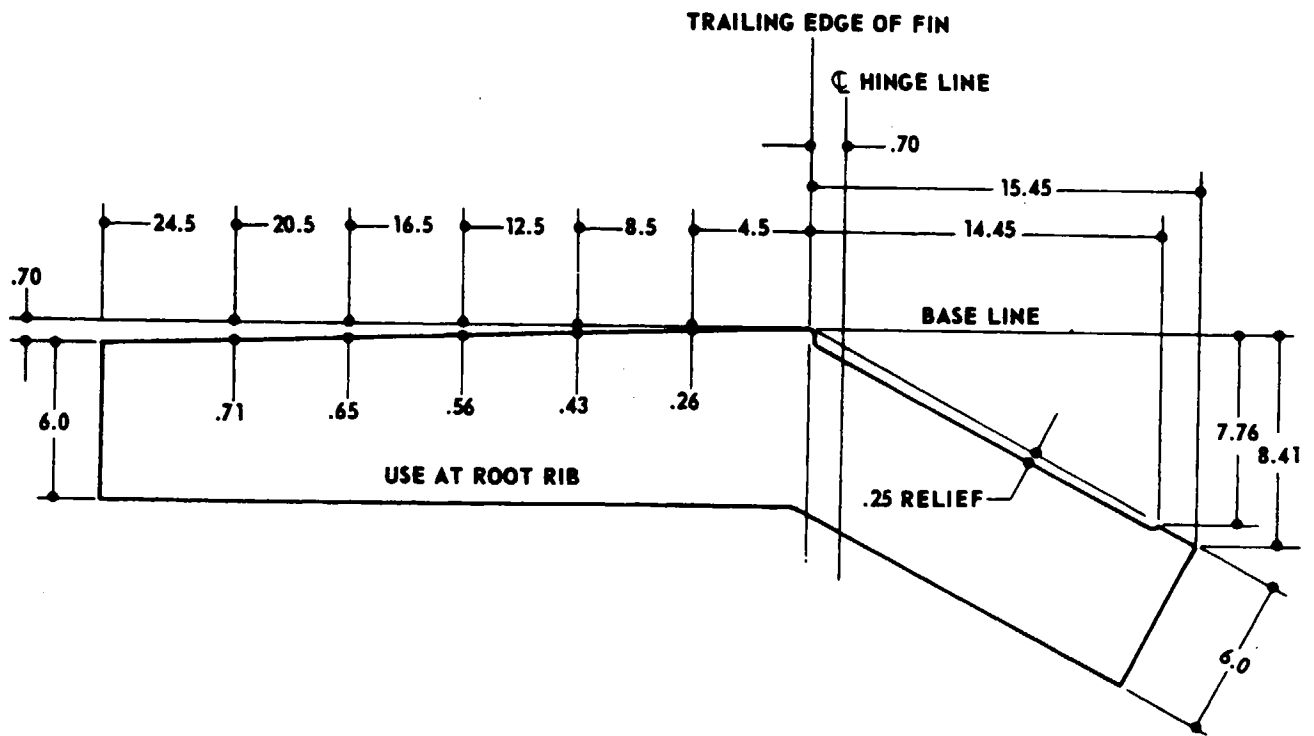

Figure 5-19. Fabricated Rudder Rigging Tool

PIPER SENECA II SERVICE MANUAL

TABLE V-III. TROUBLESHOOTING CHART (SURFACE CONTROLS)

Trouble	Cause	Remedy
AILERON CONTROL SYSTEM		
<p>Lost motion between control wheel and aileron.</p>	<p>Cable tension too low.</p> <p>Linkage loose or worn.</p> <p>Broken pulley.</p> <p>Cables not in place on pulleys.</p>	<p>Adjust cable tension. (Refer to Paragraph 5-11.)</p> <p>Check linkage and tighten or replace.</p> <p>Replace pulley.</p> <p>Install cables correctly. Check cable guards.</p>
<p>Resistance to control wheel rotation.</p>	<p>System not lubricated properly.</p> <p>Cable tension too high.</p> <p>Control column horizontal chain improperly adjusted.</p> <p>Pulleys binding or rubbing.</p> <p>Cables not in place on pulleys.</p> <p>Bent aileron and/or hinge.</p> <p>Cables crossed or routed incorrectly.</p>	<p>Lubricate system.</p> <p>Adjust cable tension. (Refer to Paragraph 5-11.)</p> <p>Adjust chain tension. (Refer to Paragraph 5-5.)</p> <p>Replace binding pulleys and/or provide clearance between pulleys and brackets.</p> <p>Install cables correctly. Check cable guards.</p> <p>Repair or replace aileron and/or hinge.</p> <p>Check routing of control cables.</p>
<p>Control wheels not synchronized.</p>	<p>Incorrect control column rigging.</p>	<p>Rig in accordance with Paragraph 5-5.</p>

TABLE V-III. TROUBLESHOOTING CHART (SURFACE CONTROLS) (cont.)

Trouble	Cause	Remedy
AILERON CONTROL SYSTEM (cont.)		
Control wheels not horizontal when ailerons are neutral.	Incorrect rigging of aileron system.	Rig in accordance with Paragraph 5-11.
Incorrect aileron travel.	Aileron control rods not adjusted properly. Aileron bellcrank stops not adjusted properly.	Adjust in accordance with Paragraph 5-11. Adjust in accordance with Paragraph 5-11.
Correct aileron travel cannot be obtained by adjusting bellcrank stops.	Incorrect rigging of aileron cables, control wheel and control rod.	Rig in accordance with Paragraph 5-11.
Control wheel stops before control surfaces reach full travel.	Incorrect rigging between control wheel and control cables.	Rig in accordance with Paragraph 5-11.

PIPER SENECA II SERVICE MANUAL

TABLE V-III. TROUBLESHOOTING CHART (SURFACE CONTROLS) (cont.)

Trouble	Cause	Remedy
STABILATOR CONTROL SYSTEM		
Lost motion between control wheel and stabilator.	Cable tension too low.	Adjust cable tension per Paragraph 5-15.
	Linkage loose or worn.	Check linkage and tighten or replace.
	Broken pulley.	Replace pulley.
	Cables not in place on pulleys.	Install cables correctly.
Resistance to stabilator control movement.	System not lubricated properly.	Lubricate system.
	Cable tension too high.	Adjust cable tension per Paragraph 5-15.
	Binding control column.	Adjust and lubricate per Paragraph 5-5.
	Pulleys binding or rubbing.	Replace binding pulleys and/or provide clearance between pulleys and brackets.
	Cables not in place on pulleys.	Install cables correctly.
	Cables crossed or routed incorrectly.	Check routing of control cables.
	Bent stabilator hinge.	Repair or replace stabilator hinge.
Binding bob weight linkage.	Inspect and adjust or replace.	
Incorrect stabilator travel.	Stabilator stops incorrectly adjusted.	Adjust stop screws per Paragraph 5-15.

PIPER SENECA II SERVICE MANUAL

TABLE V-III. TROUBLESHOOTING CHART (SURFACE CONTROLS) (cont.)

Trouble	Cause	Remedy
STABILATOR CONTROL SYSTEM (cont.)		
Correct stabilator travel cannot be obtained by adjusting stops.	<p>Stabilator cables incorrectly rigged.</p> <p>Bob weight incorrectly rigged.</p>	<p>Rig cables in accordance with Paragraph 5-15.</p> <p>Rig in accordance with Paragraph 5-15.</p>
STABILATOR TRIM CONTROL SYSTEM		
Lost motion between trim control wheel and trim tab.	<p>Cable tension too low.</p> <p>Cables not in place on pulleys.</p> <p>Broken pulley.</p> <p>Linkage loose or worn.</p>	<p>Adjust in accordance with Paragraph 5-21.</p> <p>Install cables according to Paragraphs 5-18 and 5-20.</p> <p>Replace pulley.</p> <p>Check linkage and tighten or replace.</p>
Trim control wheel moves with excessive resistance.	<p>System not lubricated properly.</p> <p>Cable tension too high.</p> <p>Pulleys binding or rubbing.</p> <p>Cables not in place on pulleys.</p> <p>Trim tab hinge binding.</p> <p>Cables crossed or routed incorrectly.</p>	<p>Lubricate system.</p> <p>Adjust in accordance with Paragraph 5-21.</p> <p>Replace binding pulleys. Provide clearance between pulleys and brackets.</p> <p>Refer to Paragraphs 5-18 and 5-20.</p> <p>Lubricate hinge. If necessary, replace.</p> <p>Check routing of control cables.</p>

PIPER SENECA II SERVICE MANUAL

TABLE V-III. TROUBLESHOOTING CHART (SURFACE CONTROLS) (cont.)

Trouble	Cause	Remedy
STABILATOR TRIM CONTROL SYSTEM (cont.)		
Trim tab fails to reach full travel.	System incorrectly rigged.	Check and/or adjust rigging per Paragraph 5-21.
	Trim drum incorrectly wrapped.	Check and/or adjust rigging per Paragraph 5-21.
Trim indicator fails to indicate correct trim position.	Trim indicator unit not adjusted properly.	Adjust in accordance with Paragraph 5-21.
RUDDER CONTROL SYSTEM		
Lost motion between rudder pedals and rudder.	Cable tension too low.	Adjust cable tension per Paragraph 5-28.
	Linkage loose or worn.	Check linkage and tighten or replace.
	Broken pulley.	Replace pulley.
	Bolts attaching rudder to bellcrank are loose.	Tighten bellcrank bolts.
Excessive resistance to rudder pedal movement.	System not lubricated properly.	Lubricate system.
	Rudder pedal torque tube bearing in need of lubrication.	Lubricate torque tube bearings.
	Cable tension too high.	Adjust cable tension per Paragraph 5-28.

PIPER SENECA II SERVICE MANUAL

TABLE V-III. TROUBLESHOOTING CHART (SURFACE CONTROLS) (cont.)

Trouble	Cause	Remedy
RUDDER CONTROL SYSTEM (cont.)		
	<p>Pulleys binding or rubbing.</p> <p>Cables not in place on pulleys.</p> <p>Cables crossed or routed incorrectly.</p>	<p>Replace binding pulleys and/or provide clearance between pulleys and brackets.</p> <p>Install cables correctly. Check cable guards.</p> <p>Check routing of control cables.</p>
Rudder pedals not neutral when rudder is streamlined.	Rudder cables incorrectly rigged.	Rig in accordance with Paragraph 5-28.
Incorrect rudder travel.	<p>Rudder bellcrank stop incorrectly adjusted.</p> <p>Nose wheel contacts stops before rudder.</p>	<p>Rig in accordance with Paragraph 5-28.</p> <p>Rig in accordance with Paragraph 5-28.</p>
RUDDER TRIM CONTROL SYSTEM		
Lost motion between trim control wheel and trim tab.	<p>Cable tension too low.</p> <p>Cables not in place on pulleys.</p> <p>Broken pulley.</p> <p>Linkage loose or worn.</p>	<p>Adjust in accordance with Paragraph 5-34.</p> <p>Install cables according to Paragraphs 5-31 and 5-33.</p> <p>Replace pulley.</p> <p>Check linkage and tighten or replace.</p>

PIPER SENECA II SERVICE MANUAL

TABLE V-III. TROUBLESHOOTING CHART (SURFACE CONTROLS) (cont.)

Trouble	Cause	Remedy
RUDDER TRIM CONTROL SYSTEM (cont.)		
<p>Trim control wheel moves with excessive resistance.</p>	<p>System not lubricated properly.</p> <p>Pulleys binding or rubbing.</p> <p>Cables not in place on pulleys.</p> <p>Trim tab hinge binding.</p> <p>Cables crossed or routed incorrectly.</p>	<p>Lubricate system.</p> <p>Replace binding pulleys. Provide clearance between pulleys and brackets.</p> <p>Install cables according to Paragraphs 5-31 and 5-33.</p> <p>Lubricate hinge. Replace if necessary.</p> <p>Check routing of control cables.</p>
<p>Trim tab fails to reach full travel.</p>	<p>System incorrectly rigged.</p> <p>Either or both trim drums incorrectly wrapped.</p>	<p>Check and/or adjust rigging per Paragraph 5-34.</p> <p>Check and/or adjust rigging per Paragraph 5-34.</p>
<p>Trim indicator fails to indicate correct trim position.</p>	<p>Trim indicator unit not adjusted properly.</p>	<p>Adjust in accordance with Paragraph 5-34.</p>

PIPER SENECA II SERVICE MANUAL

TABLE V-III. TROUBLESHOOTING CHART (SURFACE CONTROLS) (cont.)

Trouble	Cause	Remedy
FLAP CONTROL SYSTEM		
<p>Flaps fail to extend or retract.</p> <p>Flaps not synchronized or fail to move evenly when retracted.</p>	<p>Control cable broken or disconnected.</p> <p>Incorrect rigging of system.</p>	<p>Replace or reconnect control cable. Refer to Paragraph 5-37.</p> <p>Adjust flaps per instructions in Paragraph 5-38.</p>

III
INTENTIONALLY LEFT BLANK

112
INTENTIONALLY LEFT BLANK

SECTION VI

HYDRAULIC SYSTEM

Paragraph		Aerofiche Grid No.
6-1.	Introduction	114
6-2.	Description	114
6-3.	Troubleshooting	115
6-4.	Hydraulic Pump	116
6-5.	Removal of Hydraulic Pump	116
6-6.	Disassembly of Hydraulic Pump	116
6-7.	Cleaning, Inspection and Repairs of Hydraulic Pump	119
6-8.	Assembly of Hydraulic Pump	119
6-9.	Test and Adjustment of Hydraulic Pump	1110
6-10.	Installation of Hydraulic Pump	1113
6-11.	Landing Gear Free-Fall Valve Assembly	1113
6-12.	Inspection and Repair of Free-Fall Valve	1113
6-13.	Removal of Free-Fall Valve Assembly	1113
6-14.	Installation of Free-Fall Valve Assembly	1115
6-15.	Gear Actuating Cylinder	1115
6-16.	Removal of Nose Gear Actuating Cylinder	1115
6-17.	Removal of Main Gear Actuating Cylinder	1116
6-18.	Disassembly of Actuating Cylinder	1116
6-19.	Cleaning, Inspection and Repair of Gear Actuating Cylinder	1119
6-19a.	Installation of T-Rings	1119
6-20.	Assembly of Gear Actuating Cylinder	1119
6-21.	Installation of Nose Gear Actuating Cylinder	1120
6-22.	Installation of Main Gear Actuating Cylinder	1120
6-23.	Hydraulic Lines	1120
6-24.	Removal and Installation of Hydraulic Lines	1120
6-25.	Testing Hydraulic System	1121
6-26.	Servicing Hydraulic Pump/Reservoir	1121

SECTION VI

HYDRAULIC SYSTEM

6-1. INTRODUCTION. The PA-34-200T hydraulic system components covered in this section consist of the combination hydraulic pump and reservoir, hydraulic pressure switch, free-fall valve assembly, actuating cylinders and hydraulic lines. The brake system, although hydraulically operated, is not included in this section as it has its own hydraulic system independent of the gear retraction system. The brake system along with landing gear and components is covered in Section VII.

This section provides instructions for remedying difficulties which may arise in the operation of the hydraulic system. The instructions are organized so that the mechanic can refer to: Description, for a basic understanding of the system; Troubleshooting, for a methodical approach in locating difficulty; Corrective Maintenance, for the removal, repair and installation of components, and; Adjustments and Checks, for the operation of the repaired system.

CAUTION

Prior to starting any investigation of the hydraulic system, place the airplane on jacks. (Refer to Jacking, Section II.)

6-2. DESCRIPTION. Hydraulic fluid to the landing gear actuating cylinders is supplied by an electrically powered reversible pump located in the right forward area of the fuselage nose section. A reservoir is an integral part of the pump. The pump is controlled by a selector handle on the instrument panel, to the left of the control quadrant. As the handle is placed in either the up or down position, the pump directs fluid through the particular pressure line to each individual actuating cylinder. As fluid pressure increases at one side of a cylinder piston, fluid at the other side is directed back through the other line to the pump. Both lines serve either as pressure or return passages depending on the rotation of the pump to retract or extend the gear.

A pressure switch is mounted on the pressure line in the right aft side of the nose cone. This switch opens the electrical circuit to the pump solenoid when the gear fully retracts and pressure in the system increases to 1800 ± 100 PSI. The switch will continue to hold the circuit open until pressure in the system drops to approximately 1700 psi; when at that time the pump will again operate to build up pressure as long as the gear selector is in the up position. The down position of the selector handle does not affect the pressure switch.

The hydraulic pump is a gear type unit driven by a 12 volt reversible motor designed to operate in a pressure range of 2000 to 2500 psi. To prevent excessive buildup of pressure in the hydraulic system due to expansion, a primary thermal relief valve is incorporated on early - O models and is located directly above the nose gear actuating cylinder. This relief valve will maintain pressure in the system up to 2350 ± 50 psi. An additional relief valve is incorporated in the pump which will open at 4000 ± 300 psi and allow fluid to flow into the reservoir. On later - 2 models the external thermal relief is not used in the system. The relief valve in the pump is used which will open at 2250 ± 50 psi. to prevent excessive buildup of pressure in the hydraulic system due to expansion. Other valves in the pump, channel fluid to the proper outlet during, retraction or extension of the gear. A shuttle valve located in the base of the pump allows fluid displaced by the cylinder pistons to return to the reservoir without backpressure. This shuttle valve has a delivery pressure of 400-800 psi during the extension cycle.

A bypass free-fall valve assembly is incorporated in the system to permit extension of the landing gear should a malfunction in the system occur. This valve is manually operated by means of an emergency gear knob located on the instrument panel. This knob must be fully extended to permit emergency extension. Restrictions in the system prevent the gear from extending too fast.

For a description of the landing gear and electrical switches, refer to Section VII, Landing Gear and Brake System.

CAUTION

Prior to starting any investigation of the hydraulic system, place the airplane on jacks. With the airplane on jacks, pull the free-fall valve knob full out thus preventing the buildup of unnecessary pressure on the actuating cylinders and connecting hydraulic lines when the gear is raised or lowered manually. Failure to comply with these instructions could result in the buildup of sufficient pressure to unlock the downlock mechanism allowing the gear to collapse when the wing jacks are removed. Prior to removing the airplane from jacks, push the free-fall valve knob in, turn on the master switch and select gear down, observe that all three green lights indicating the landing gear is down and locked are energized. Turn master switch off.

6-3. TROUBLESHOOTING. Malfunctions in the hydraulic system will result in failure of the landing gear to operate properly. When trouble develops, jack up the airplane (refer to Jacking, Section II) and then proceed to determine the extent of the trouble. Generally, hydraulic system troubles fall into two types; troubles involving the hydraulic supplying system and troubles in the landing gear hydraulic system. Table VI-III at the back of this section, lists the troubles which may be encountered and their probable cause, and suggests a remedy for the trouble involved. A hydraulic system operational check may be conducted using Figures 6-1 or 6-2. When the trouble has been recognized, the first step in troubleshooting is isolating the cause. Hydraulic system troubles are not always traceable to one cause. It is possible that a malfunction may be the result of more than one difficulty within the system. Starting first with the most obvious and most probable reasons for the trouble, check each possibility and, in turn, by process of elimination, isolate the troubles.

NOTE

If it is found that the hydraulic pump is at fault and requires disassembly, it is recommended that it be overhauled by an accredited overhaul facility. Pressure checks with adjustments may be accomplished in accordance with instructions given in Paragraphs 6-6 thru 6-9.

6-4. HYDRAULIC PUMP.

6-5. REMOVAL OF HYDRAULIC PUMP. The hydraulic pump with reservoir incorporated is located in the nose section of the fuselage. Access to the pump is through the access panel in the nose baggage compartment.

- a. Disconnect the pump electrical leads from the pump solenoid relays and the ground wire from the battery shelf.
- b. Disconnect the hydraulic lines from the pump. Cap the line ends to prevent contamination.
- c. Remove pump by removing pump attaching bolts.

6-6. DISASSEMBLY OF HYDRAULIC PUMP. (Refer to Figure 6-3.) After the hydraulic pump has been removed from the airplane, cap or plug all ports, and clean exterior of pump using a dry cleaning solvent to remove accumulated dirt and dust. The three major components of the pump assembly are the pump base, pump motor, and valve and gear case. These three major components should be disassembled as follows:

- a. Pump Base: Remove pump base (16) from valve and gear case by:
 1. Cutting safety wire and removing bolts (17) with washers securing pump base to pump and gear case.
 2. The check valve within the pump base should be removed for cleaning purposes only. To remove valve, cut safety wire and remove bolt, spring and steel ball. Replace O-ring at reassembly.
- b. Pump Motor: The pump motor may be removed from the pump and disassembled as follows:
 1. Remove thru bolts (4) from head (1) of motor. Using a knife cut the seal coating between the motor head and case.
 2. Lift the head up from the case approximately .50 of an inch, this will allow inspection of brushes (3) without the brushes unseating from the commutator. (Refer to Paragraph 6-7 for brush inspection.) The brush leads are secured to the head assembly.
 3. Raise the head assembly (1) off the armature (8) and note the small thrust ball (7) located between the end of the armature (8) and motor head. Do not misplace this bearing.
 4. Draw the armature from the motor frame (9). Note the number of thrust washers (11) mounted on the drive end of the armature shaft.
 5. Remove the motor frame from the pump reservoir (13).
- c. Valve and Gear Case: Remove valve and gear case (15) from reservoir (13) as follows:
 1. Remove eight screws from flange of body and separate the two assemblies (18).
 2. Pump gears and valves should be removed for cleaning purposes only. To remove cap securing gears, remove attaching bolts. The two valve springs should be positively identified with their cavities; otherwise, it will be necessary to readjust each valve for proper operating pressure.

PIPER SENECA II SERVICE MANUAL

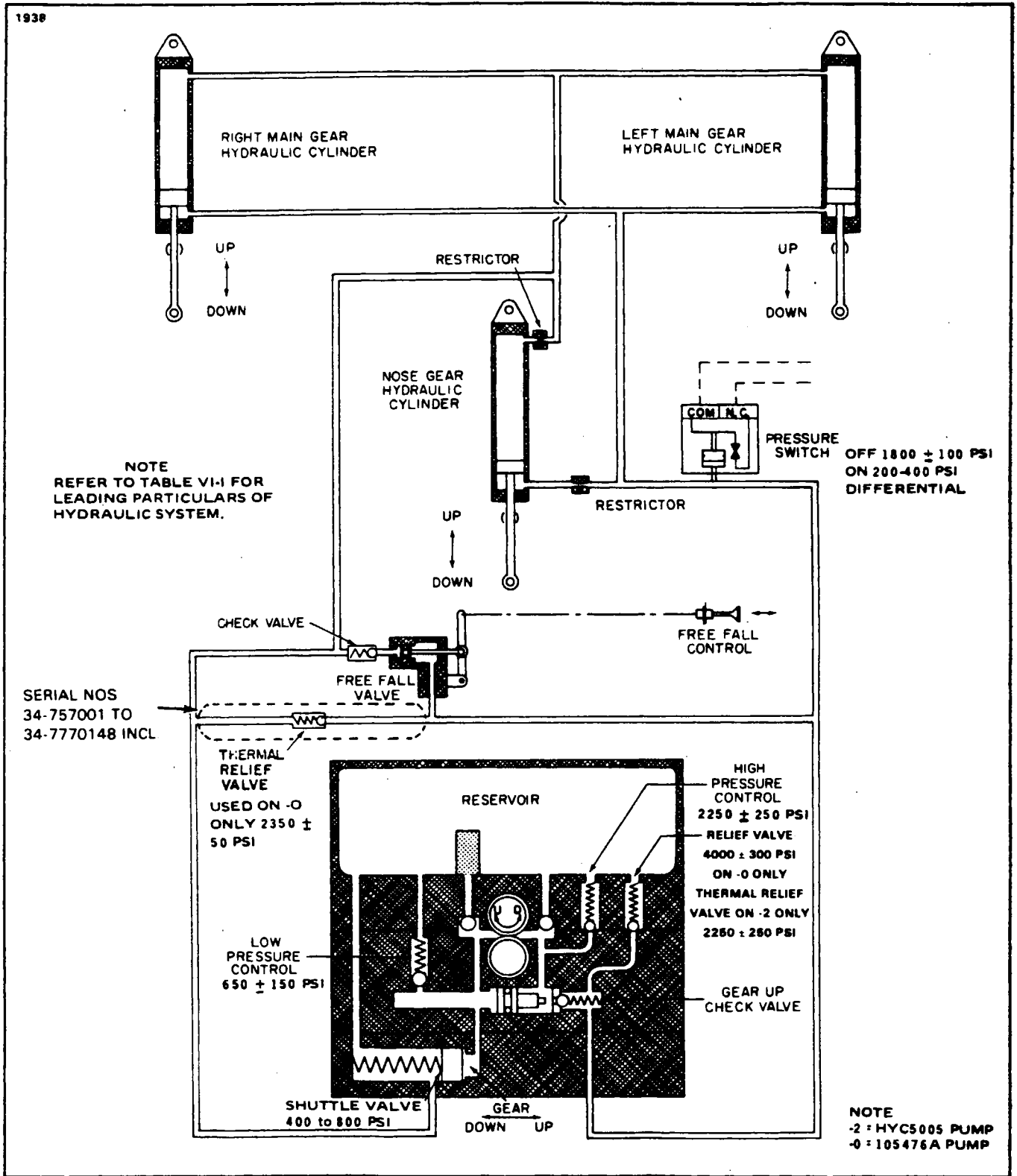

Figure 6-1. Schematic Diagram of Hydraulic System

Reissued: 10/11/79

HYDRAULIC SYSTEM

PIPER SENECA II SERVICE MANUAL

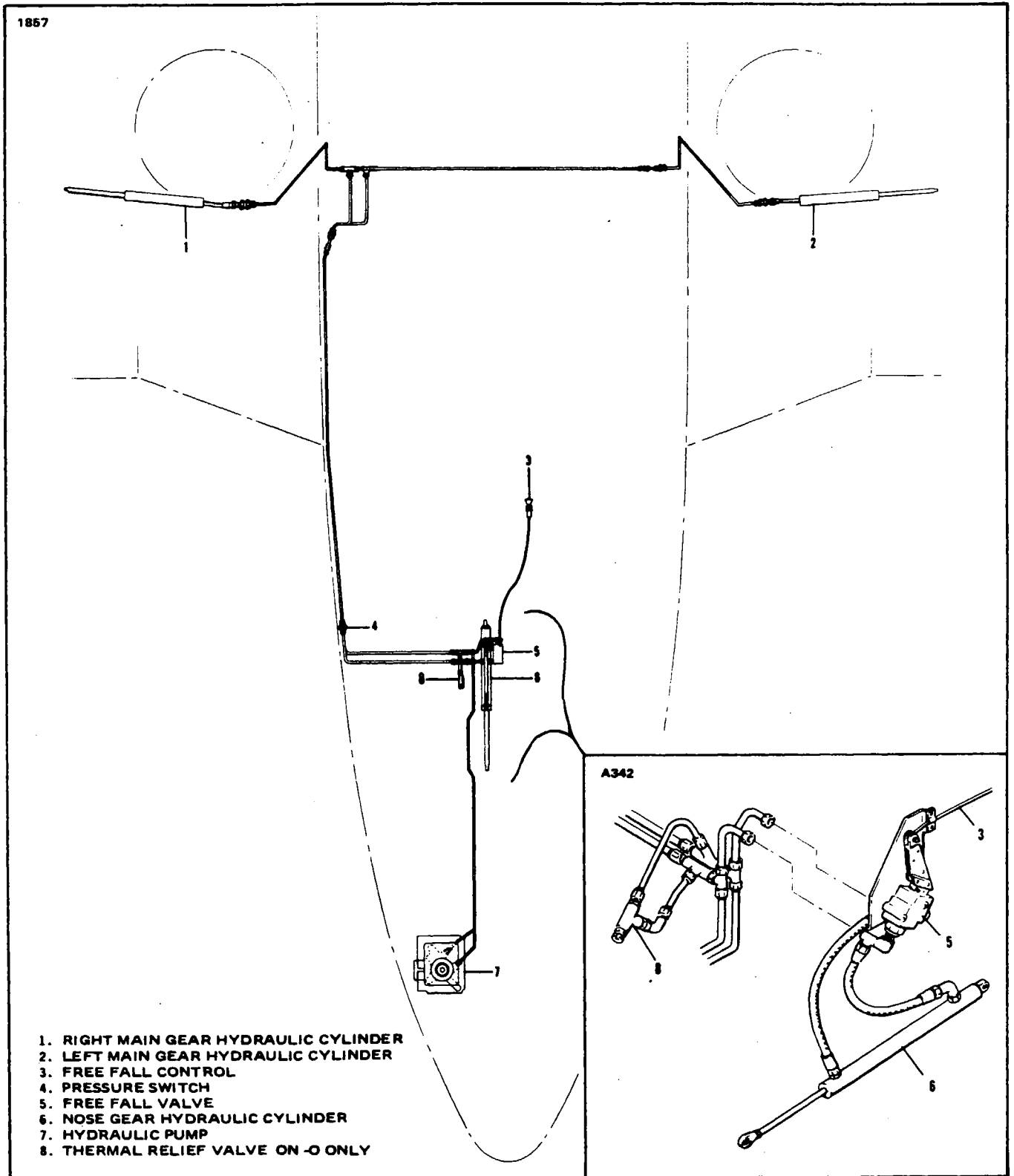

Figure 6-2. Hydraulic System Installation

Reissued: 10/11/79

HYDRAULIC SYSTEM
Issued 9/4/74.

6-7. CLEANING, INSPECTION AND REPAIRS OF HYDRAULIC PUMP.

NOTE

Repair facilities must be clean to prevent contamination of pump components. Proper and careful handling should be exercised to prevent damaging pump components.

- a. Discard all O-rings.
- b. Remove caps or plugs and clean all components with a dry type cleaning solvent and dry thoroughly.
- c. Inspect pump components for scatches, scores, chips, cracks and wear.
- d. Inspect motor for worn brushes (minimum of .218 of an inch brush remains between the braided and commutator end), excess commutator wear and excess bearing wear.
- e. Repairs are limited to O-ring and brush replacement as follows:
 1. One brush holder has the winding wire attached. Locate this wire and remove by using a soldering gun.
 2. The head assembly can now be removed and worked on for ease of brush replacement if required.
 3. Remove brush wire and brush from bimetal heat protector.
 4. Solder new brush wires to head assembly and bimetal heat protector, and wire from winding to one brush holder.
 5. Install brush springs and brushes into brush holders and secure in place (temporary) with a piece of string looped around the brush and holder and tied in a knot.

NOTE

Insure that the braided wire is in the holder slot for proper brush movement.

6. Install the head assembly with new brushes to the frame and commutator in accordance with instructions given in Paragraph 6-8, Step a.

6-8. ASSEMBLY OF HYDRAULIC PUMP. (Refer to Figure 6-3.)

- a. The pump motor may be assembled and installed on the reservoir as follows:
 1. Position motor frame (9) on reservoir (13). Note aligning marks on frame and reservoir.
 2. Place thrust washers (11), of the same amount removed, on the drive end of the armature (8).
 3. Lubricate the entire length of the armature shaft, on the drive end, with light grease to protect O-ring seal from damage. Insert end of shaft in reservoir.
 4. Saturate felt oiling pad around commutator end bearing with SAE 20 oil. Allow excess oil to drain off before assembling motor.
 5. Insert thrust ball (7) in bearing of motor head (1). To hold ball in position, place a small amount of grease inside the bearing.
 6. Place head assembly on frame and allow brushes to extend over commutator. Remove the string securing the brushes in the holders. Push head assembly on frame and insure proper indexing of head and frame assemblies. Secure in place with thru bolts (4).
 7. Check freedom of rotation and end play (thrust) of the armature within the assembly. A minimum of .005 inch end play is permissible. Adjust to this tolerance if necessary by adding or removing thrust washers (11) on drive end of armature shaft.

PIPER SENECA II SERVICE MANUAL

- b. Assemble valve and gear case (15) to the reservoir (13) as follows:
 - 1. If removed, place pump gears in valve and gear case and install cover. Install cover attaching bolts and secure.
 - 2. Lubricate reservoir seal ring (14) with hydraulic fluid (MIL-H-5606) and place in recess provided in case (15).
 - 3. Position reservoir (13) on valve and gear case (15). Care should be taken when aligning the armature shaft with the pump gear. Do not run the motor to accomplish this.
 - 4. Ascertain that the seal ring (14) is properly positioned, and install attaching screws. Tighten one screw to hold the assembly together, then, with the motor connected to a 14 volt source and an ammeter in the circuit, tighten the rest of the screws such that the current drawn does not exceed 12 amperes.
- c. Attach the pump base to the pump as follows:
 - 1. With pump inverted, lubricate O-ring seals and install them in recesses provided in the valve and gear case (15).
 - 2. Install attaching bolts with washers and torque to 70 inch-pounds.
 - 3. Safety attaching bolts with MS20995-C32 wire.
- d. Conduct motor operational check not to exceed 10 seconds running time.

6-9. TEST AND ADJUSTMENT OF HYDRAULIC PUMP. (Refer to Figure 6-4.)

- a. Test Equipment:
 - 1. Hydraulic pump and mounting base.
 - 2. Pressure gauge (0 - 1000 psi).
 - 3. Pressure gauge (0 - 3000 psi).
 - 4. Hoses with fittings to connect base and gauges.
 - 5. Power supply (14 VDC).
 - 6. Ammeter (0 to 100 amps).
 - 7. Fuse or circuit protector (100 amps).
- b. Test and Adjustment:

NOTE

Test gauges or gauges of known accuracy should be used when performing the following tests.

- 1. Connect the 0 to 1000 psi gauge to the low pressure port of the pump base.
- 2. Connect the 0 to 3000 psi gauge to the high pressure port of the pump base.
- 3. Connect black lead of pump motor to the negative terminal of the DC power supply.
- 4. Remove the filler plug located on the forward side of the pump. Loosen vent screw and add fluid, MIL-H-5606, through the filler hole until full. Reinstall the filler plug and tighten the vent screw.
- 5. Bleed air from the attached lines. (Lines may be bled by alternately connecting blue lead and green lead to the positive terminal of the power supply until all air is exhausted.)
- 6. Connect blue lead to positive terminal of power supply. Pump should operate and the high pressure gauge should indicate between 2000 and 2500 psi. (Should the gauge indicate a pressure below 2000 psi or over 2500 psi, adjust valve "A," Figure 6-3 accordingly to obtain the desired reading.)

NOTE

When increasing pressure, the pump running time must not exceed 12 seconds. There should be no external leakage while performing Steps 5 thru 8.

2024

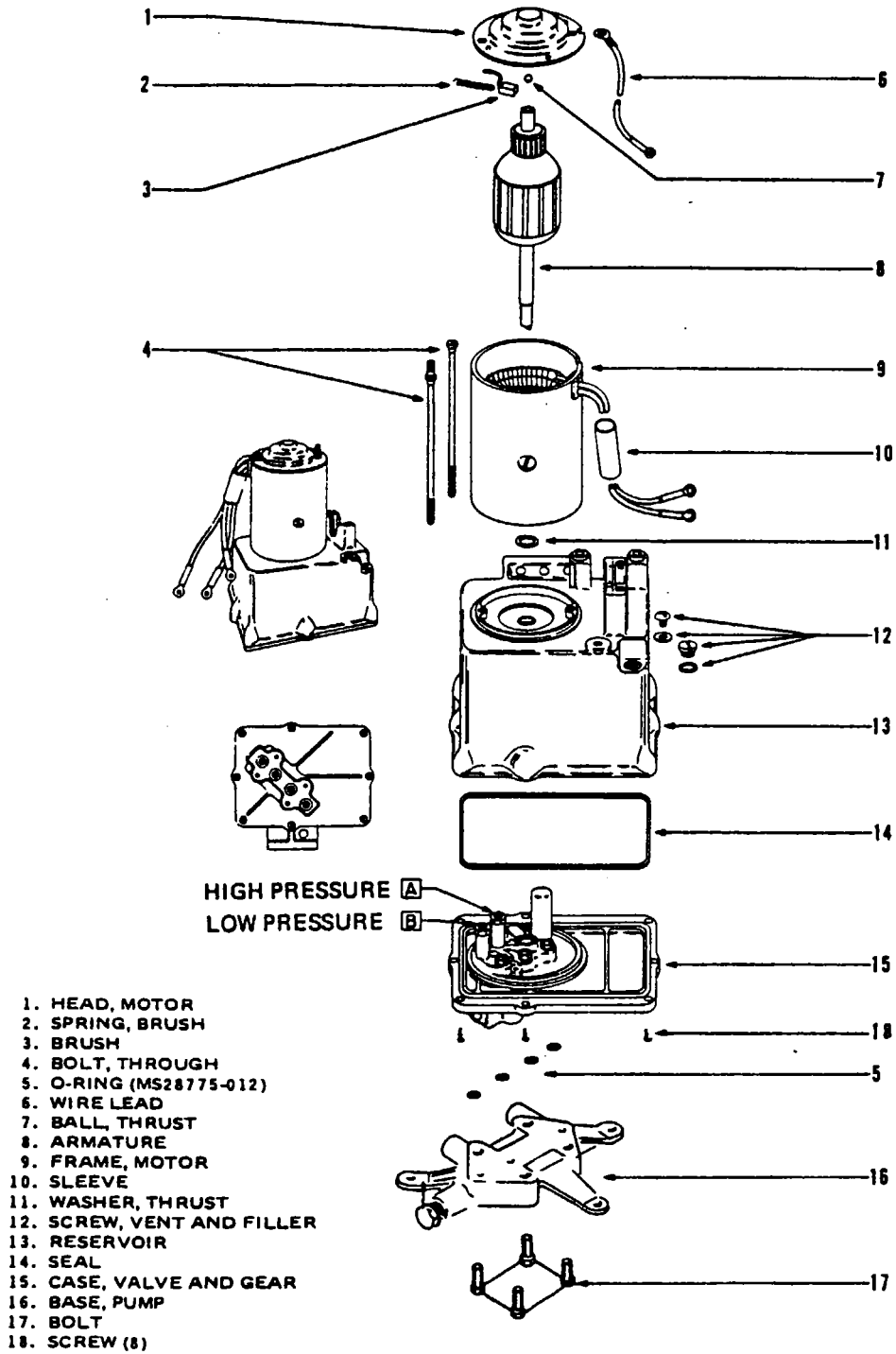

Figure 6-3. Hydraulic Pump/Reservoir, Exploded View

PIPER SENECA II SERVICE MANUAL

TABLE VI-I. LEADING PARTICULARS, HYDRAULIC PUMP

Hydraulic Pump: High Pressure Low Pressure Flow Rate @ 1000 psi High Pressure Control Hydraulic Fluid Relief valve Relief valve Shuttle Valve Delivered Pressure System Thermal Relief (AN6245-AB4) Pressure Switch Open (OFF) Pressure Close (ON) Pressure	2000 to 2500 psi 650 ± 150 psi 45 cu. in. per min. 2000 to 2500 psi MIL-H-5606 -O Only 4000 ± 300 psi -2 Only 2250 + 250 psi -O-2 400 to 800 psi -O 2350 + 50 psi 1800 ± 100 psi Pressure decreasing 200 to 400 psi
--	--

TABLE VI-II. CHARACTERISTICS, HYDRAULIC PUMP MOTOR

Electrical Characteristics:	
Voltage Rotation Polarity Operating Current Operating Time Overload Protection Automatic Reset Time Location, Automatic Reset	12 DC Reversible Negative ground 75 amps, max. at 12 volts (both rotations) 12 seconds max. with a current load of 75 amperes at 77° F Thermal circuit breaker 12 seconds, max. Commutator end head of motor
Mechanical Characteristics:	
Bearings End Play, Armature	Absorbent bronze (Drive end bearing in upper pump and valve assembly casting.) Steel ball (Thrust, between commutator end head and end of armature shaft.) .005 inch, min. (Adjust by selection of thrust washers on drive end of armature shaft.)

7. Disconnect blue lead. The high pressure reading should not drop more than 300 psi in five minutes. High pressure may not be selected again for five minutes.

8. Connect green lead to positive terminal of power supply. Pump should operate in reverse, dropping reading on high pressure gauge to zero. The low pressure gauge should indicate 500 to 800 psi. (Should the gauge indicate a pressure below 500 psi or over 800 psi, adjust valve "B," Figure 6-3, accordingly to obtain desired reading.) Disconnect green lead. Both pressure gauges should indicate zero psi.

9. Should it be necessary to check the pump motor, first connect the ammeter in the electrical circuit with the positive terminal of the meter to the black lead and negative terminal of the meter to the negative terminal of the DC power supply.

10. Connect the blue lead from the pump motor to the positive terminal of the power supply. With high pressure indication within 2000 to 2500 psi range on the pressure gauge, the ammeter should read 75 amperes maximum. Disconnect the blue lead.

11. Connect the green lead from the pump motor to the positive terminal of the power supply. With low pressure indication within the 500 to 800 psi range, the ammeter should read between 15 to 35 amperes.

NOTE

In the event any of the various tests do not perform satisfactorily, the pump assembly should be replaced.

12. Disconnect the green lead from the power supply and permit the pressure to drop before disconnecting the hydraulic lines.

6-10. INSTALLATION OF HYDRAULIC PUMP. (Refer to Figure 6-5.)

a. Align three washers (7) over each hole in shelf (4). Insert grommet (1) through mounting holes in pump base (2). Insert bushing (3) through hole in each grommet.

b. Position pump on washers. Insert bolt (6) with top washer (7) through bushing (3), bottom washers (7) and shelf (4). Mount nut (8) and washer (5) on bolt and tighten.

c. Connect hydraulic lines to pump.

d. Connect pump electrical leads. Blue wire to outboard lower solenoid, green wire in inboard (upper) solenoid, and black wire to ground on bottom shelf.

e. Check fluid level in pump. (Refer to Section II for filling instructions.)

f. With aircraft on jacks, operate pump to purge hydraulic system of air, and check for leaks. After operation, recheck fluid level.

6-11. LANDING GEAR FREE-FALL VALVE ASSEMBLY.

6-12. INSPECTION AND REPAIR OF FREE-FALL VALVE. This valve is located directly above the nose wheel actuating cylinder. Inspection is limited to determining if any signs of hydraulic fluid leakage are evident around the seam between the end fitting and valve body, and around the periphery of the piston assembly shaft. If leaks appear, the valve assembly should be replaced since it is impractical to repair the valve.

6-13. REMOVAL OF FREE-FALL VALVE ASSEMBLY. (Refer to Figure 6-6.) In the event it becomes necessary to replace the free-fall valve assembly, proceed as follows:

a. Loosen three screws and clamp securing cable in position and withdraw cable.

b. Disconnect hydraulic lines connected to the valve. Place a rag in position to absorb any hydraulic fluid spillage that may result. Cap the lines to avoid contamination.

c. Remove the hex head bolts securing the valve and bracket to the frame and remove the assembly from the airplane.

PIPER SENECA II SERVICE MANUAL

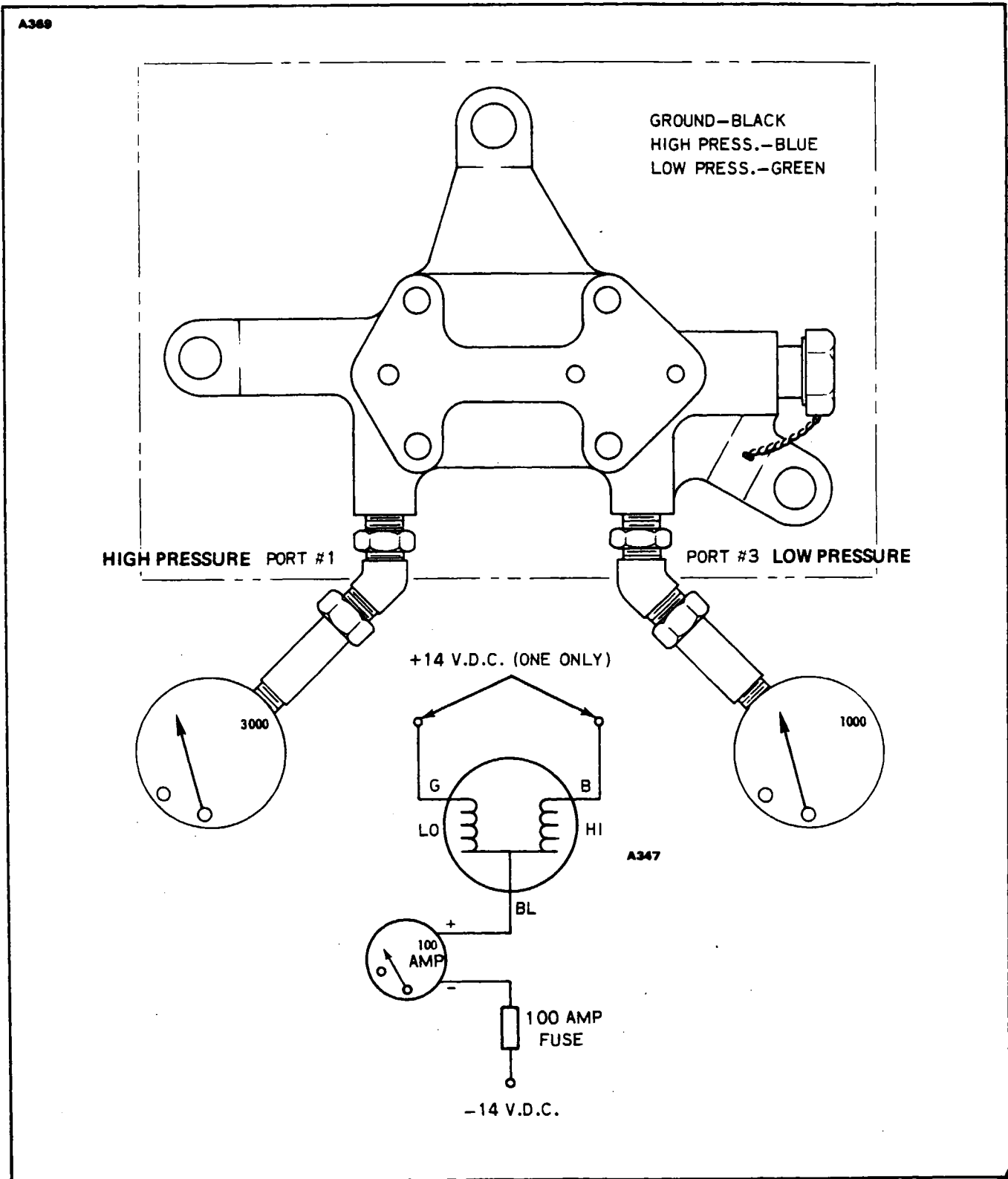

Figure 6-4. Test and Adjustments of Hydraulic Pump

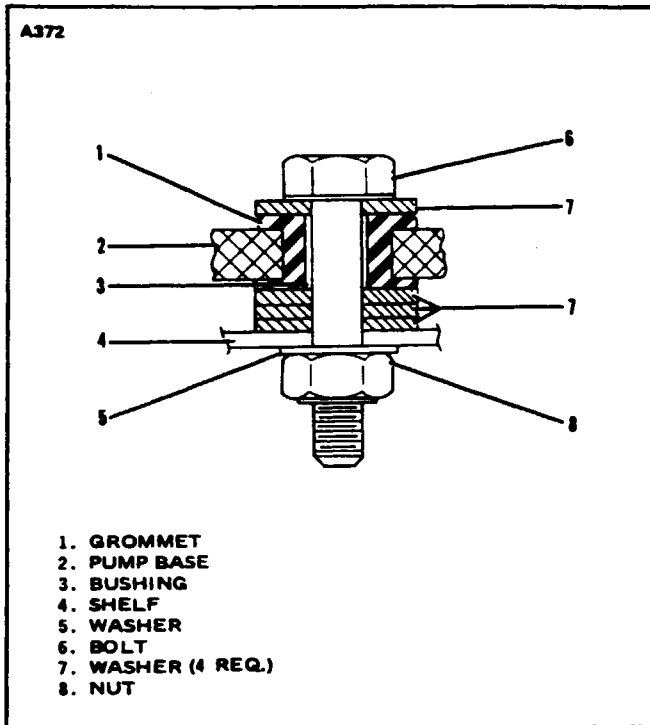

Figure 6-5. Pump Mounting

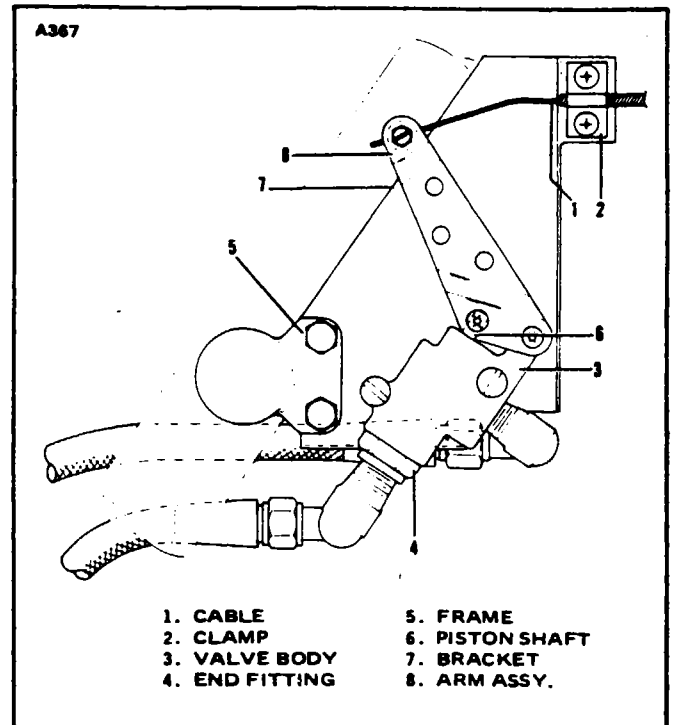

Figure 6-6. Free-Fall Valve Assembly

d. Remove rivet and nut securing link to piston shaft. Note position of elbow and tee fittings to assure their being replaced in the same position at reassembly. Remove fittings and two bolts securing the valve to the bracket.

6-14. INSTALLATION OF FREE-FALL VALVE ASSEMBLY. (Refer to Figure 6-6.)

- a. Apply Lubon #404, or equivalent, to MALE threads of elbows and tees and insert fittings in valve. Lubon should be applied sparingly to prevent it entering the hydraulic system.
- b. Install valve on bracket and secure in position. Push piston shaft into the valve until it bottoms. Align hole in link with hole in piston shaft and insert rivet. Attach nut to rivet.
- c. Position bracket with valve on frame. Apply Lubon #404 to MALE threads of tees and connect hydraulic lines.
- d. Push arm assembly fully forward. Pull cable full forward. Place clamp over reinforced portion of cable and tighten screws. Insert loose end of cable through the hole in the bushing of the arm assembly. Tighten lock screw on cable.

6-15. GEAR ACTUATING CYLINDER.

6-16. REMOVAL OF NOSE GEAR ACTUATING CYLINDER.

- a. Place airplane on jacks. (Refer to Jacking, Section II.)
- b. Disconnect hydraulic lines from actuating cylinder and cover open line ends to prevent contamination.

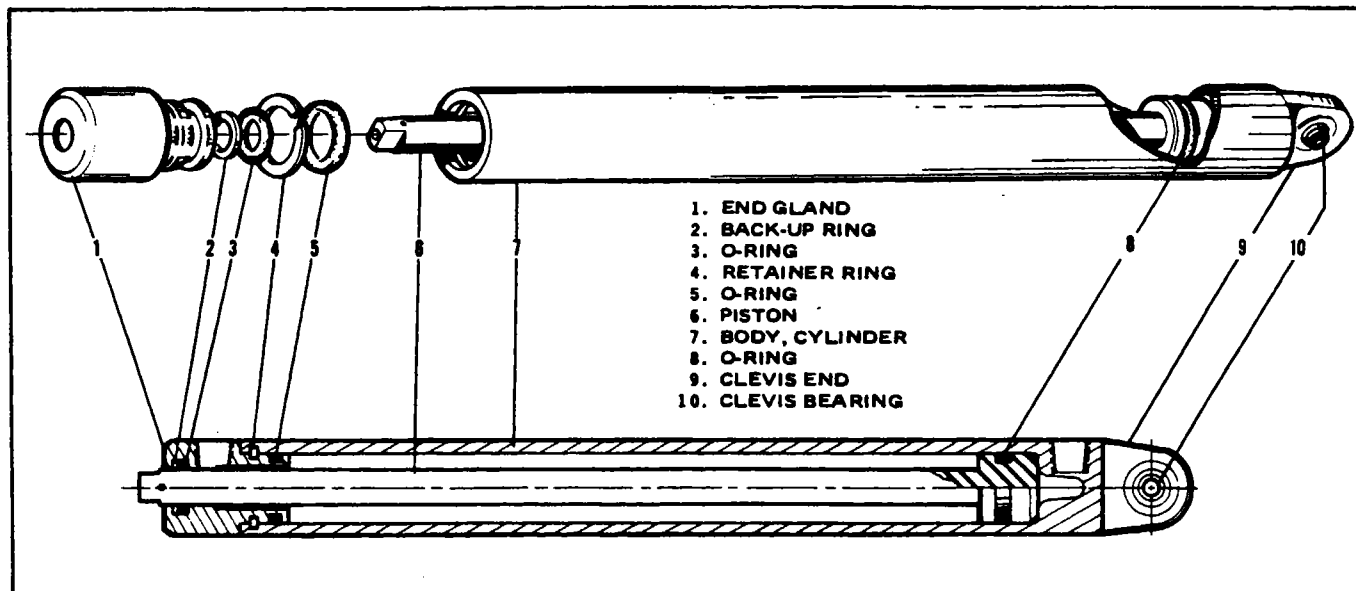

Figure 6-7. Gear Actuating Cylinder

- c. Disconnect operating rod end from the bracket on the trunnion assembly by removing attaching bolt and nut.
- d. Disconnect cylinder from the link assembly. The downlock spring and downlock link are also attached to this link assembly. After removing the cylinder, it is suggested the spring and link be temporarily reinstalled until the cylinder is ready for reinstallation.
- e. Remove the cylinder from the wheel well.

6-17. REMOVAL OF MAIN GEAR ACTUATING CYLINDER.

- a. Place airplane on jacks. (Refer to Jacking, Section II.)
- b. Disconnect hydraulic lines from actuating cylinder and cover open line ends to prevent contamination.
- c. Disconnect gear downlock spring from swivel fitting at upper end of spring.
- d. Remove downlock spring swivel fitting and disconnect cylinder operating rod end from upper side brace retraction fitting by removing attaching nut, washer and bolt.
- e. Disconnect cylinder from its attachment by removing nut and bolt.
- f. Remove cylinder from wheel well.

6-18. DISASSEMBLY OF ACTUATING CYLINDER. (Refer to Figure 6-7.)

NOTE

The following disassembly, cleaning, inspection, repair and assembly instructions apply to nose gear actuator and both main gear actuators.

- a. Using hand pressure, push piston rod (6) toward clevis end (9) to remove oil from the cylinder.
- b. Place clevis in a soft jaw vise and clamp against the clevis bearing (10).
- c. Install any 1/8-27 pipe fitting into the port on the end gland. This fitting is used for leverage only and need not be tight. (Refer to Figure 6-8.)

PIPER SENECA II SERVICE MANUAL

C232

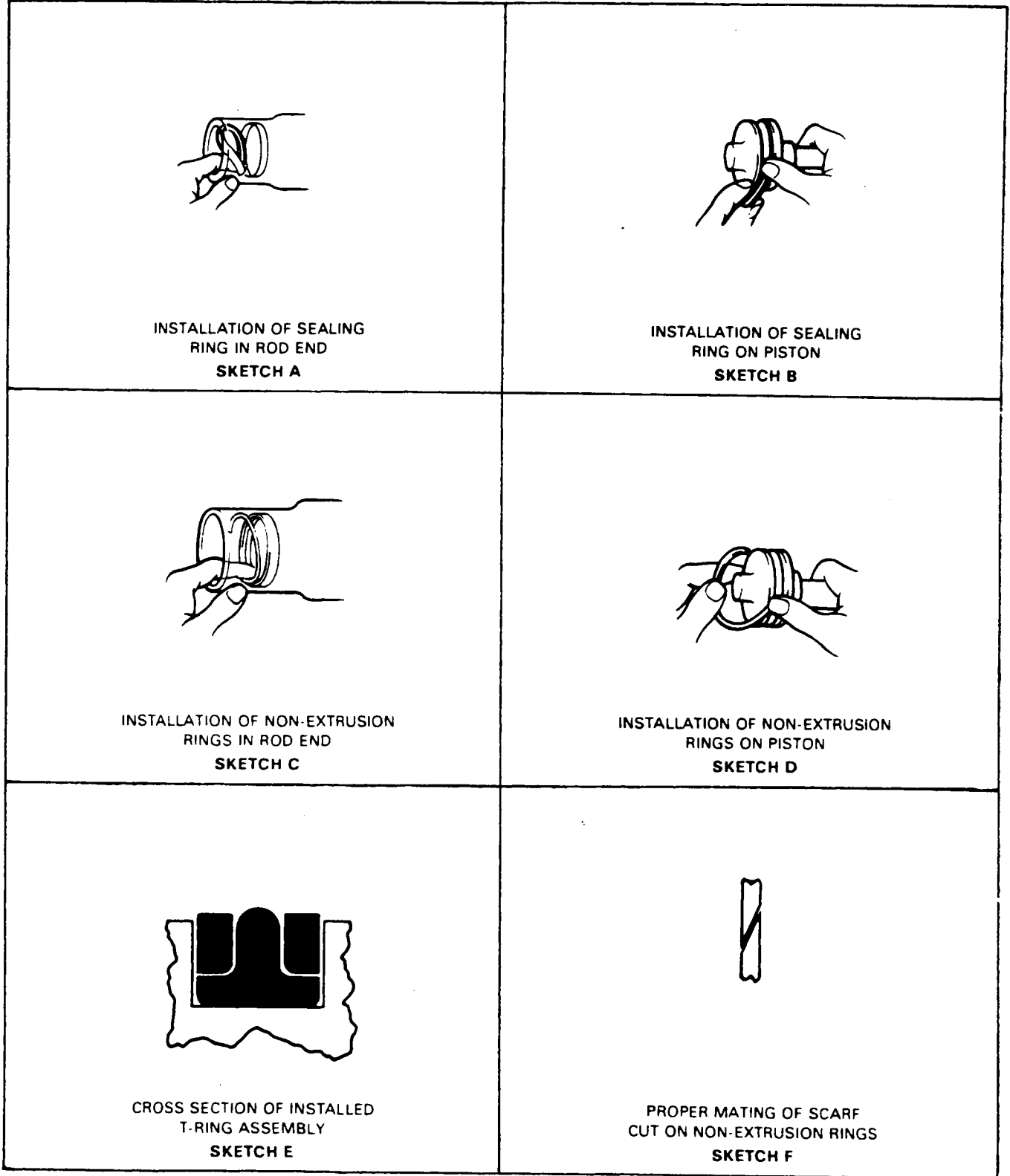

Figure 6-7a. Installation of T-Rings

Added: 12/08/83

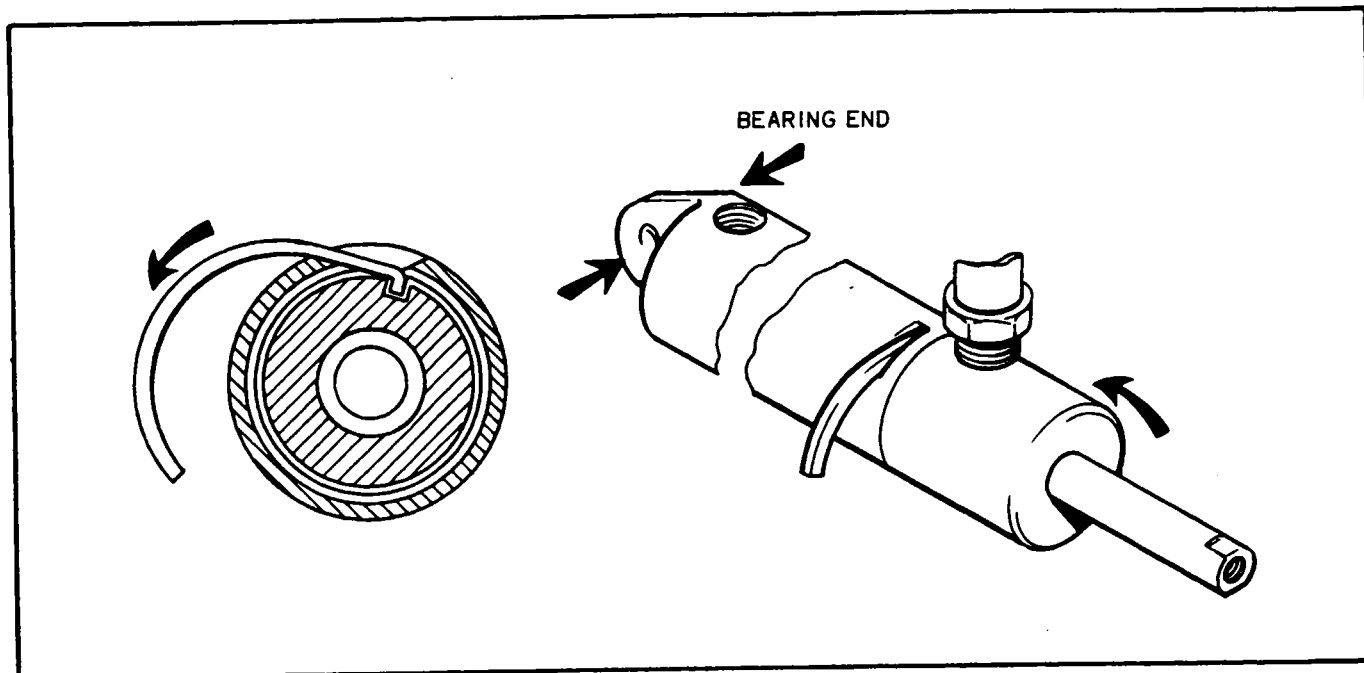

Figure 6-8. End Gland Locking Device

- d. Rotate end gland counterclockwise (with use of fitting) until end of retainer ring (4. Figure 6-7) shows in slot of cylinder body (7). Reverse rotation of gland (clockwise direction) allowing retainer ring to move out of slot. (It may be necessary to give the ring an assist in starting out of the slot. If so, insert a strong wire pick or other suitable tool in the slot to pry up the end of the retainer ring.)
- e. Remove piston (6) and end gland (1) from cylinder body.
- f. Remove O-rings as required.

6-19. CLEANING, INSPECTION AND REPAIR OF GEAR ACTUATING CYLINDER.

- a. Clean cylinder components with a suitable dry type solvent and dry thoroughly.
- b. Inspect cylinder assembly for the following:
 1. Interior walls of cylinder and exterior surface of the piston for scratches, burrs, corrosion, etc.
 2. Stripped or damaged threads.
 3. Rod end fitting and swivel fitting of cylinder for wear and corrosion.
 4. End fitting retainer slot for excess wear.
- c. Repairs to the cylinder are limited to polishing out small scratches, burrs, etc., and replacing components. (Refer to Parts Catalog for replacement part numbers.)

6-19a. INSTALLATION OF T-RINGS. (Refer to Figure 6-7a.)

- a. Place synthetic sealing ring into groove. Insure that seal is not twisted and that it lies flat in the groove. (Refer to Sketches A and B.)
- b. Orient each non-extrusion ring so that the radiused corner (if there is one) will be mated to the seal when installed. (Refer to Sketch E.)
- c. Insert one end of the non-extrusion ring (formed by the scarf cut) into the space between the side of the groove and the side of the seal. (Refer to Sketch E.)
- d. Work the entire circumference into this space, insuring that the scarf cut of the non-extrusion ring is properly mated. (Refer to Sketch F.)
- e. Repeat Steps c and d for the second non-extrusion ring.
- f. Spread a few drops of system hydraulic oil evenly around the sealing edge of the packing.

6-20. ASSEMBLY OF GEAR ACTUATING CYLINDER. (Refer to Figure 6-7.)

- a. Install O-rings (3), (5) and (8) in their respective positions.
- b. Lubricate areas around O-rings with hydraulic fluid, park-o-lube or vaseline. Slide end gland (1) on piston rod (6). Slide piston into cylinder body (7).
- c. Insert hook end of new lock ring (4), (P/N 755 997), in slot of cylinder body and slot in end gland. Rotate gland counterclockwise to completely wrap lock ring into assembly.
- d. Align port in end gland and cylinder body.
- e. Check smoothness of operation of piston and static test unit to check for possible cut O-rings.
- f. Clean nose cylinder orifices.

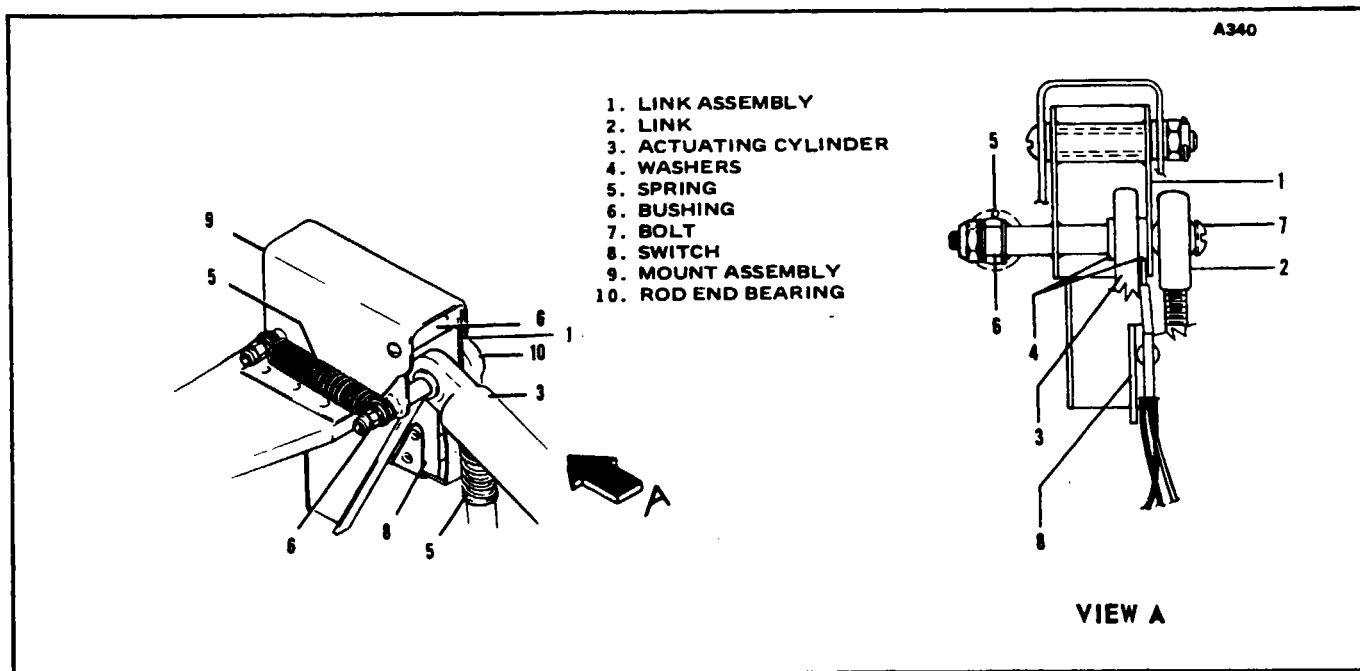

Figure 6-9. Nose Gear Actuating Cylinder Installation

6-21. INSTALLATION OF NOSE GEAR ACTUATING CYLINDER. (Refer to Figure 6-9.)

- a. Refer to Paragraph 6-16, d. Remove bolt (7) far enough to position clevis end of actuating cylinder (3) in the link assembly (1). Reinsert bolt with callouts (1) thru (6) arranged as illustrated in Figure 6-9.
- b. Insert the operating rod end into the bracket on the trunnion assembly and secure with bolt, nut and washers.
- c. Connect hydraulic lines to their respective fittings on the actuating cylinder.
- d. Check adjustment of cylinder rod end. (Refer to Adjustment of Nose Landing Gear, Section VII.)
- e. Operate pump to purge system of air and check fluid level in reservoir.
- f. Remove airplane from jacks.

6-22. INSTALLATION OF MAIN GEAR ACTUATING CYLINDER.

- a. Attach the cylinder to its attachment fitting in the wheel well using bolt and nut.
- b. Attach the operating rod end and downlock spring swivel fitting to the upper side brace retraction fitting using washer and nut. The swivel fitting must be free to rotate.
- c. Connect downlock spring to swivel fitting.
- d. Check adjustment of cylinder rod end. (Refer to Adjustment of Main Landing Gear, Section VII.)
- e. Operate pump and purge system of air. Check fluid level in reservoir.
- f. Remove the airplane from jacks.

6-23. HYDRAULIC LINES.

6-24. REMOVAL AND INSTALLATION OF HYDRAULIC LINES. Remove damaged hydraulic lines by disconnecting fittings at both ends and disconnecting where secured by brackets. Refer to Figure 6-2 as an aid in locating attaching brackets and bends in lines. Provide a small, clean container for draining the lines. Install a new or repaired line in reverse. Operate the pump to purge air from the system. Check fluid level in the reservoir.

6-25. TESTING HYDRAULIC SYSTEM. The hydraulic system should be tested to determine that it functions properly after performing any service or repairs. It is suggested that the airplane be connected to an outside power source in order to conserve the battery. (Refer to External Power Receptacle, Section II.)

CAUTION

Turn master switch OFF before inserting or removing external power supply plug.

- a. Place airplane on jacks. (Refer to Jacking, Section II.)
- b. With gear down, master switch ON, and circuit breaker closed, place landing gear selector handle in the UP position. The pump should immediately start operating and the gear retract. The red gear unsafe light on the instrument panel should light up until the gear is fully retracted. The hydraulic pump should stop operating after full retraction of the gear.
- c. Place gear selector handle in DOWN position. The gear should extend and lock in position. Gear down lights on the instrument panel will light up when all three gears are locked in position. Inspect hydraulic system for leakage of hydraulic fluid.
- d. Recycle the landing gear to determine that it functions properly.
- e. To check operation of the free-fall valve assembly, retract the landing gear and turn the master switch off. Pull the free-fall valve knob full out. The landing gear should extend and lock in position.

CAUTION

Prior to removing the airplane from jacks, turn master switch on and determine that all three green lights are energized. This will indicate the landing gear is down and locked.

6-26. SERVICING HYDRAULIC PUMP/RESERVOIR. The fluid level of the reservoir of the combination pump and reservoir should be checked every 50 hours by viewing the fluid through the filler plug hole in the hydraulic pump. Access to the pump is through the panel at the right forward side of the nose baggage compartment.

To check fluid level, remove the filler plug located on the forward side of the pump and ascertain that fluid is visible up to the bottom of the filler plug hole. Should fluid be below the hole, add fluid, MIL-H-5606, through the filler hole until full. Reinstall the filler plug and tighten.

NOTE

A small vent hole is located under the vent screw head. Retain 1/64 inch clearance between the screw head and the small vent hole.

PIPER SENECA II SERVICE MANUAL

TABLE VI-III. TROUBLESHOOTING CHART (HYDRAULIC SYSTEM)

Trouble	Cause	Remedy
<p>Landing gear retraction system fails to operate.</p>	<p>Landing gear actuator circuit breaker open.</p>	<p>Reset circuit breaker and determine cause for open circuit breaker.</p>
	<p>Landing gear selector circuit breaker open.</p>	<p>Reset circuit breaker and determine cause for open circuit breaker.</p>
	<p>Landing gear actuator circuit wires broken.</p>	<p>Check wiring.</p>
	<p>Landing gear selector circuit wires broken.</p>	<p>Check wiring.</p>
	<p>Safety (squat) switch out of adjustment.</p>	<p>Readjust switch. (Refer to Adjustment of Safety Switch, Section VII.)</p>
	<p>Squat switch inoperative.</p>	<p>Replace switch.</p>
	<p>Pressure switch inoperative.</p>	<p>Replace switch.</p>
	<p>Pump retraction solenoid inoperative (inboard solenoid).</p>	<p>Replace solenoid.</p>
<p align="center">NOTE</p> <p>If the retracting solenoid of the pump can be heard to actuate when operating the gear selector switch, it may be assumed that the gear control circuit is operating properly and the actuator circuit should be further checked.</p>		
	<p>Gear selector switch ground incomplete.</p>	<p>Check ground.</p>
	<p>Gear selector switch inoperative.</p>	<p>Replace switch.</p>
	<p>Hydraulic pump ground incomplete.</p>	<p>Check ground.</p>

TABLE VI-III. TROUBLESHOOTING CHART (HYDRAULIC SYSTEM) (cont)

Trouble	Cause	Remedy
<p>Landing gear retraction system fails to operate. (cont)</p>	<p>Hydraulic pump inoperative.</p> <p>Hydraulic fluid in reservoir below operating level.</p> <p>Battery low or dead.</p> <p>Check for internal leakage of free fall valve.</p> <p>Check for internal leakage of gear up check valve in pump.</p>	<p>Replace or overhaul pump.</p> <p>Fill reservoir with hydraulic fluid.</p> <p>Check condition of battery.</p> <p>Replace valve.</p> <p>Replace or overhaul pump.</p>

PIPER SENECA II SERVICE MANUAL

TABLE VI-III. TROUBLESHOOTING CHART (HYDRAULIC SYSTEM) (cont)

Trouble	Cause	Remedy
<p>Landing gear extension system fails to operate.</p>	<p>Landing gear actuator circuit breaker open.</p> <p>Landing gear selector circuit breaker open.</p> <p>Landing gear actuator circuit wires broken.</p> <p>Landing gear selector circuit wires broken.</p> <p>Pump extension solenoid inoperative (outboard solenoid).</p>	<p>Reset circuit breaker and determine cause for open circuit breaker.</p> <p>Reset circuit breaker and determine cause for open circuit breaker.</p> <p>Check wiring.</p> <p>Check wiring.</p> <p>Replace solenoid.</p>

NOTE

If the extension solenoid of the pump can be heard to actuate when operating the gear selector switch, it may be assumed that the gear control circuit is operating properly and the actuator circuit should be further checked.

PIPER SENECA II SERVICE MANUAL

TABLE VI-III. TROUBLESHOOTING CHART (HYDRAULIC SYSTEM) (cont)

Trouble	Cause	Remedy
<p>Landing gear extension system fails to operate. (cont)</p>	<p>Gear selector switch ground incomplete.</p> <p>Gear selector switch inoperative.</p> <p>Hydraulic pump ground incomplete.</p> <p>Hydraulic pump inoperative.</p> <p>Hydraulic fluid in reservoir below operating level.</p> <p>Low or dead battery.</p>	<p>Check ground.</p> <p>Replace switch.</p> <p>Check ground.</p> <p>Replace or overhaul pump.</p> <p>Fill reservoir with hydraulic fluid.</p> <p>Check condition of battery.</p>
<p>Landing gear retraction extremely slow.</p>	<p>Hydraulic fluid in reservoir below operating level.</p> <p>Restriction in hydraulic lines.</p>	<p>Fill reservoir with hydraulic fluid.</p> <p>Isolate and check hydraulic lines.</p>
<p>Pump stops during gear retraction.</p>	<p>Landing gear actuator circuit breaker opens.</p> <p>Landing gear selector circuit breaker opens.</p> <p>Pressure switch out of adjustment.</p> <p>Mechanical restriction or obstruction in hydraulic system to allow pressure to build up and shut off pump before gear has retracted.</p>	<p>Reset circuit breaker and determine cause for overload.</p> <p>Reset circuit breaker and determine cause for overload.</p> <p>Remove and readjust or replace switch.</p> <p>Place airplane on jacks and run retraction check. Isolate and determine cause.</p>

PIPER SENECA II SERVICE MANUAL

TABLE VI-III. TROUBLESHOOTING CHART (HYDRAULIC SYSTEM) (cont)

Trouble	Cause	Remedy
<p>Pump stops during gear extension.</p>	<p>Landing gear actuator circuit breaker opens.</p> <p>Landing gear selector circuit breaker opens.</p>	<p>Reset circuit breaker and determine cause for overload.</p> <p>Reset circuit breaker and determine cause for overload.</p>
<p>Pump fails to shut off though gear has fully retracted.</p>	<p>Pressure switch inoperative.</p> <p>Pressure switch out of adjustment.</p> <p>Pump retraction solenoid sticking (inboard solenoid).</p> <p>Internal leakage of system.</p> <p>External leakage of system.</p> <p>Pump relief valve out of adjustment.</p>	<p>Replace switch.</p> <p>Replace switch.</p> <p>Replace solenoid.</p> <p>Check gear actuating cylinders and free fall valve for internal leakage.</p> <p>Check for internal damage to hydraulic pump.</p> <p>Check gear actuating cylinders for external leakage.</p> <p>Check for broken or damaged hydraulic lines or hoses.</p> <p>Replace pump.</p>

TABLE VI-III. TROUBLESHOOTING CHART (HYDRAULIC SYSTEM) (cont)

Trouble	Cause	Remedy
<p>Pump fails to shut off though the gear has fully extended.</p>	<p>Pump extension solenoid sticking (outboard solenoid).</p> <p>Nose gear down limit switch actuator out of adjustment.</p> <p>Nose gear down limit switch failed.</p> <p>Main gear down limit switch out of adjustment.</p> <p>Main gear down limit switch failed.</p>	<p>Replace solenoid.</p> <p>Adjust switch actuator. (Refer to Adjustment of Nose Gear Down Limit Switch, Section VII.)</p> <p>Replace switch.</p> <p>Adjust switch. (Refer to Adjustment of Main Gear Down Limit Switch, Section VII.)</p> <p>Replace switch.</p>
<p>NOTE</p> <p>The out of adjustment or failed switch may be determined by noting which down light is not lit.</p>		
<p>Pump running intermittently after gear has retracted.</p>	<p>Leakage of high pressure check valve.</p> <p>Internal leakage of system.</p> <p>External leakage of system.</p>	<p>Remove pump and replace check valve.</p> <p>Check free fall valve for internal leakage.</p> <p>Check gear actuating cylinders for internal leakage.</p> <p>Check gear actuating cylinders for external leakage.</p> <p>Check for broken or damaged hydraulic lines.</p>

PIPER SENECA II SERVICE MANUAL

TABLE VI-III. TROUBLESHOOTING CHART (HYDRAULIC SYSTEM) (cont)

Trouble	Cause	Remedy
Gear stops part way up, but pump continues to run.	Pump high pressure relief valve out of adjustment. Internal leakage of system. Hydraulic fluid in reservoir below operating level.	Replace pump. Check gear actuating cylinders and free fall valve for internal leakage. Check for broken or damaged hydraulic lines. Fill reservoir with hydraulic fluid.
All gears fail to free-fall.	Free-fall valve fails to open.	Check valve and replace.

SECTION VII

LANDING GEAR AND BRAKE SYSTEM

Paragraph		Aerofic Grid No
7-1.	Introduction	1J7
7-2.	Description	1J7
7-3.	Troubleshooting	1J7
7-4.	Landing Gear System	1J8
7-5.	Nose Landing Gear	1J8
	7-6. Disassembly of Nose Gear Oleo	1J8
	7-7. Cleaning, Inspection and Repair of Nose Gear Oleo	1J8
	7-8. Assembly of Nose Gear Oleo	1J15
	7-9. Removal of Nose Landing Gear	1J15
	7-10. Cleaning, Inspection and Repair of Nose Landing Gear	1J21
	7-11. Installation of Nose Landing Gear	1J21
	7-12. Alignment of Nose Landing Gear	1K1
	7-13. Removal of Nose Gear Door Assembly	1K1
	7-14. Cleaning, Inspection and Repair of Nose Gear Door Assembly	1K1
	7-15. Installation of Nose Gear Door Assembly	1K2
	7-16. Adjustment of Nose Gear Door	1K3
7-17.	Main Landing Gear System	1K3
	7-18. Disassembly of Main Gear Oleo	1K3
	7-19. Cleaning, Inspection and Repair of Main Gear Oleo	1K3
	7-20. Assembly of Main Gear Oleo	1K8
	7-21. Removal of Main Landing Gear	1K9
	7-22. Cleaning, Inspection and Repair of Main Landing Gear	1K9
	7-23. Installation of Main Landing Gear	1K12
	7-24. Adjustment of Main Landing Gear	1K13
	7-25. Alignment of Main Landing Gear	1K14
	7-26. Removal of Main Gear Door Assembly	1K15
	7-27. Cleaning, Inspection and Repair of Main Gear Door Assembly	1K15
	7-28. Installation of Main Gear Door Assembly	1K15
	7-29. Adjustment of Main Gear Door Assembly	1K18
7-30.	Landing Gear Limit Switches	1K18
	7-31. Adjustment of Nose Gear Up Limit Switch	1K18
	7-32. Adjustment of Nose Gear Down Limit Switch	1K18
	7-33. Adjustment of Main Gear Up Limit Switch	1K18
	7-34. Adjustment of Main Gear Down Limit Switch	1K19
	7-35. Adjustment of Landing Gear Safety Switch (Squat Switch) and Ground Stall Warning Prevention Switch	1K20

Revised: 8/10/80

Paragraph		Aerofiche Grid N
7-36.	Landing Gear Warning Switch (Throttle Switch)	1K20
7-37.	Landing Gear Up/Power Reduced Warning Switch	1K20
7-38.	Switch Location	1K20
7-39.	Adjustment of Landing Gear Up/Power Reduced Warning Switch	1K20
7-40.	Replacement of Landing Gear Up/Power Reduced Warning Switch	1K21
7-40a.	Functional Test of Landing Gear Retraction System	1K21
7-41.	Wheels	1K23
7-42.	Removal and Disassembly of Nose Wheel	1K23
7-43.	Inspection of Nose Wheel Assembly	1K23
7-44.	Assembly and Installation of Nose Wheel	1K23
7-45.	Removal and Disassembly of Main Wheel	1L1
7-46.	Bearing Cup Replacement	1L2
7-47.	Inspection of Main Wheel Assembly	1L2
7-48.	Assembly and Installation of Main Wheel	1L2
7-49.	Brake System	1L2
7-50.	Wheel Brake Assembly	1L2
7-51.	Removal and Disassembly of Wheel Brake Assembly	1L2
7-52.	Cleaning, Inspection and Repair of Wheel Brake Assembly	1L3
7-53.	Assembly and Installation of Wheel Brake Assembly	1L6
7-54.	Brake Master Cylinder (Hand Parking Brake)	1L7
7-55.	Removal of Brake Master Cylinder	1L7
7-56.	Disassembly of Brake Master Cylinder	1L7
7-57.	Cleaning, Inspection and Repair of Brake Master Cylinder	1L7
7-58.	Assembly of Brake Master Cylinder	1L10
7-59.	Installation of Brake Master Cylinder	1L10
7-60.	Brake Cylinder (Toe Brake)	1L11
7-61.	Removal of Brake Cylinder	1L11
7-62.	Disassembly of Brake Cylinder	1L11
7-63.	Cleaning, Inspection and Repair of Brake Cylinder	1L11
7-64.	Assembly of Brake Cylinder	1L11
7-65.	Installation of Brake Cylinder	1L13
7-66.	Brake Bleeding Procedure (Gravity)	1L13
7-67.	Brake Bleeding Procedure (Pressure)	1L13
7-68.	Brake System Leak Check	1L14

SECTION VII

LANDING GEAR AND BRAKE SYSTEM

7-1. INTRODUCTION. This section contains instructions for overhauling, inspecting and adjusting the various components of the PA-34-200T landing gear and brake system. Also included are adjustments for the electrical limit, safety and warning switches. This section does not cover the hydraulic function of the landing gear, except brakes, this information may be found in Section VI, Hydraulic System.

7-2. DESCRIPTION. The PA-34-200T airplane is equipped with a retractable tricycle air-oil strut type landing gear, hydraulically raised or extended by an electrically powered reversible pump. A selector switch in the instrument panel to the left of the control quadrant is used to select gear UP or DOWN position.

Gear positions are indicated by three green lights directly above the selector switch when the gear is down and locked, and a red light at the top of the instrument panel when gear is unsafe. Activation of all three downlock switches will shut the hydraulic pump off. As the instrument lights are turned on, the green lights will dim.

As manifold pressure drops below approximately 14 inches of mercury, and if the landing gear has not been extended, a throttle switch located in the quadrant will actuate a warning horn indicating to the pilot the landing gear is still up. The warning horn will continue to operate until the landing gear is down and locked, at which time three green lights on the instrument panel will energize.

It is preferred the landing gear be extended and retracted by means of the gear selector knob; however, in the event of hydraulic or electrical failure, the gear can be extended by pulling the free-fall valve thus permitting the gear to fall free. The nose and main gear require no assist springs. Once the gear are down and the downlock hooks engage, a spring maintains pressure on each hook in the locked position until released by hydraulic pressure.

In the event the airplane is sitting on the ground, and the gear selector knob is in the "UP" position, a safety switch (squat switch) located on the left main gear will prevent the hydraulic pump from actuating if the main switch should be turned on. When the plane leaves the ground, as in flight, the safety switch will actuate when the oleo extends in excess of 8 inches, and the hydraulic pump will raise the landing gear. In the event the airplane is placed on jacks and raised to the extent the oleo will extend in excess of 8 inches, the safety switch will actuate the hydraulic pump, thus raising the landing gear if the landing gear selector knob is in the "UP" position and the main switch is turned on.

The nose gear is steerable by the use of the rudder pedals. As the gear retracts, the steering linkage becomes separated from the gear so that rudder pedal action with gear retracted is not impeded by the nose gear operation. A gear centering spring mechanism is incorporated in the nose gear steering mechanism.

The two main wheels are equipped with self-adjusting single disc hydraulic brake assemblies which are actuated by individual toe brake cylinders mounted on the rudder pedals and a handle connected to a brake cylinder located below and forward of the center of the instrument panel. A parking brake is incorporated with the handle, and is used by pulling back on the handle and pushing forward on the button to the left of the handle. To release the hand brake, pull aft on the handle and allow it to swing forward. The cylinders are supplied hydraulic fluid from a reservoir located on the forward side of the cabin main bulkhead.

7-3. TROUBLESHOOTING. Mechanical and electrical troubles peculiar to the landing gear system are listed in Table VII-IV at the back of this section. When troubleshooting, first eliminate hydraulic malfunctions as listed in Section VI. Then proceed to switch malfunctions and last to the mechanical operation of the gear itself, both of which are included in this section.

CAUTION

When it becomes necessary to raise or lower either the nose gear or the main gear manually, the free-fall valve knob should be pulled full out thus preventing the buildup of unnecessary pressure on the actuating cylinders and connecting hydraulic lines. Failure to comply with these instructions could result in the buildup of sufficient pressure to unlock the downlock mechanism allowing the gear to collapse when the wing jacks are removed.

7-4. LANDING GEAR SYSTEM.

7-5. NOSE LANDING GEAR.

7-6. DISASSEMBLY OF NOSE GEAR OLEO. (Refer to Figure 7-1.) The nose gear oleo assembly may be removed and disassembled from the trunnion assembly with the gear removed from or installed in the airplane.

NOTE

Prior to proceeding with instructions contained in this section, the airplane must be placed on jacks. (Refer to Jacking, Section II.)

- a. With the airplane mounted on jacks, place a drip pan under the nose gear to catch spillage.
- b. Remove air and fluid from the oleo strut assembly. Depress the air valve core pin until strut pressure is released. Remove the air valve body (15) and, using a thin hose, siphon as much hydraulic fluid from the strut as possible.
- c. To remove oleo cylinder (26), piston strut (30) and fork (39) from the trunnion assembly (23), cut safety wire (2) and remove four bolts and washers (1) securing the tiller (20) to the top of the oleo cylinder.
- d. Disconnect nose gear centering spring assembly (11) by removing attaching hardware connecting the spring assembly to the strut housing.
- e. Remove oleo cylinder and fork assembly (39) from the trunnion assembly. The upper and lower shoulder bushings (17 and 22) should remain pressed in the trunnion.
- f. To remove the piston strut (30) and fork (39) from the oleo cylinder, first separate upper and lower torque links (33) and remove snap ring (37) from the bottom of the oleo cylinder.
- g. Pull the piston strut with components from the cylinder. Remove two pins (28) and slide components from cylinder.

7-7. CLEANING, INSPECTION AND REPAIR OF NOSE GEAR OLEO.

- a. Clean all parts using a suitable dry type cleaning solvent.
- b. Inspect components of the landing gear as follows:
 1. Bearings and bushings for excessive wear, corrosion, scratches and overall condition.
 2. Retaining pins for wear.
 3. Lock rings for cracks, nicks, burrs and overall condition.
 4. Cylinder and piston strut for excessive wear, corrosion, scratches and nicks.
 5. Orifice hole for obstruction.
 6. Fork for misalignment, cracks or other damage.
 7. Air valve for general condition.
- c. Repair of the oleo is limited to smoothing out minor scratches, nicks and dents, and replacement of parts.

PIPER SENECA II SERVICE MANUAL

1. CAP BOLTS & WASHERS
2. SAFETY WIRE
3. TRUNNION ASSY
4. BOLT, BEARING, WASHER, NUT & COTTER PIN
5. BOLT, WASHER, NUT & COTTER PIN
6. BOLT, BUSHING, WASHER, NUT & COTTER PIN
7. AXLE
8. TUBE - SPACER
9. PLUG - WHEEL END
10. TIE ROD AND NUT (2)
11. NOSE GEAR CENTERING SPRING ASSY
12. DELETED
13. CAP - AIR VALVE
14. CORE - AIR VALVE
15. BODY - AIR VALVE
16. WASHER
17. BUSHING - SHOULDER (UPPER)
18. SCREW, WASHER AND NUT
19. ROLLER ASSY AND BUSHING
20. TILLER
21. DELETED
22. BUSHING - SHOULDER (LOWER)
23. TRUNNION ASSY
24. PLACARD
25. O-RING
26. OLEO CYLINDER
27. BEARING
28. PIN - RETAINING
29. SPACER
30. PISTON, STRUT
31. O-RING
32. BEARING
33. LINK, TORQUE
34. O-RING
35. RING - WIPER
36. WASHER
37. RING - SNAP
38. BOLT, WASHER & NUT
39. FORK
40. NUT (MS20364-428C)
41. WASHERS (5 EA.) (AN960-416)
42. WASHER (62833-123)
43. BOLT (AN24-20A)

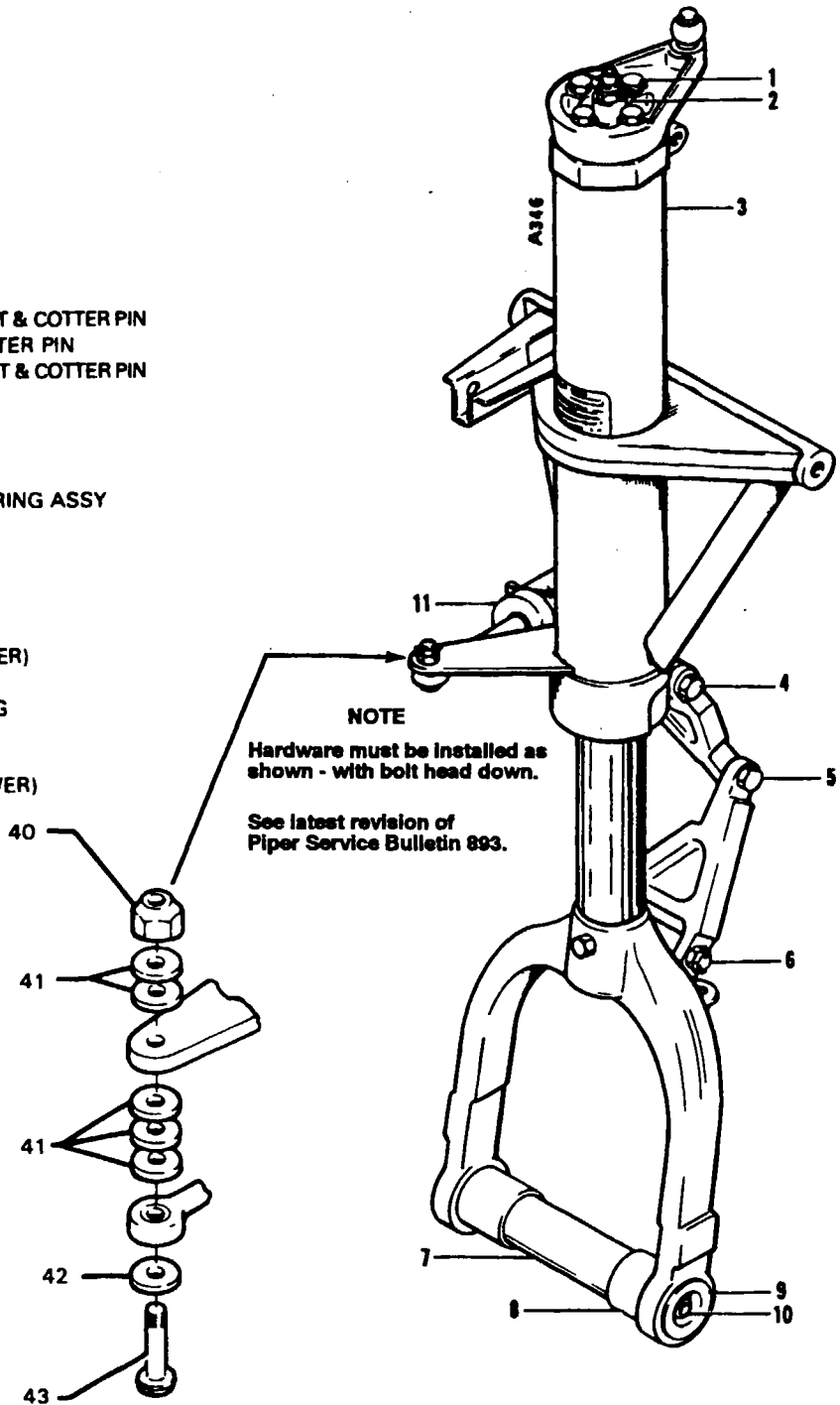

Figure 7-1. Nose Gear Oleo Strut Assembly

Revised: 8/10/80
Interim Revision: 02/05/97

LANDING GEAR AND BRAKE SYSTEM

1884

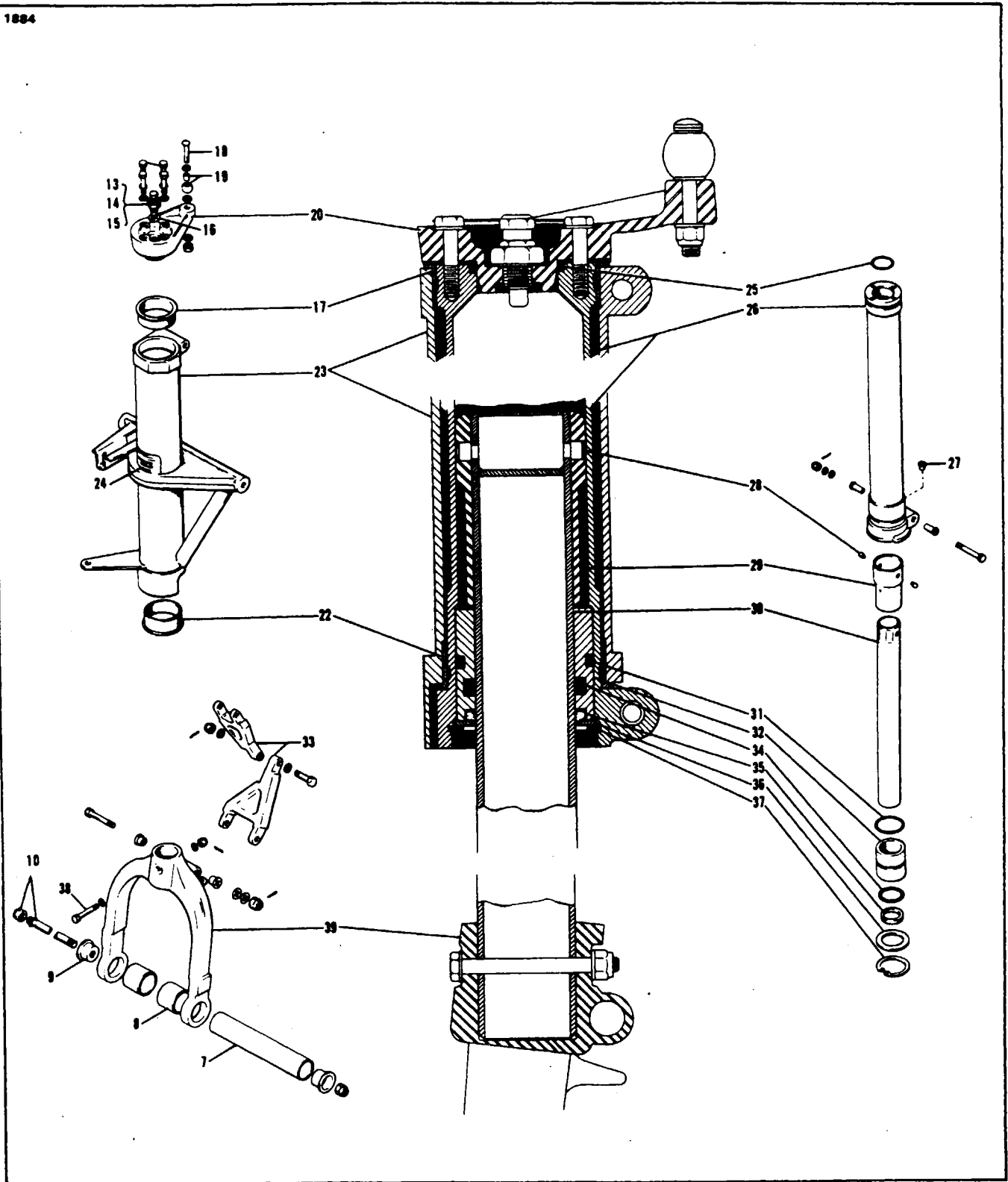

Figure 7-1. Nose Gear Oleo Strut Assembly (cont.)

Revised: 8/10/80

1J10

LANDING GEAR AND BRAKE SYSTEM

3190

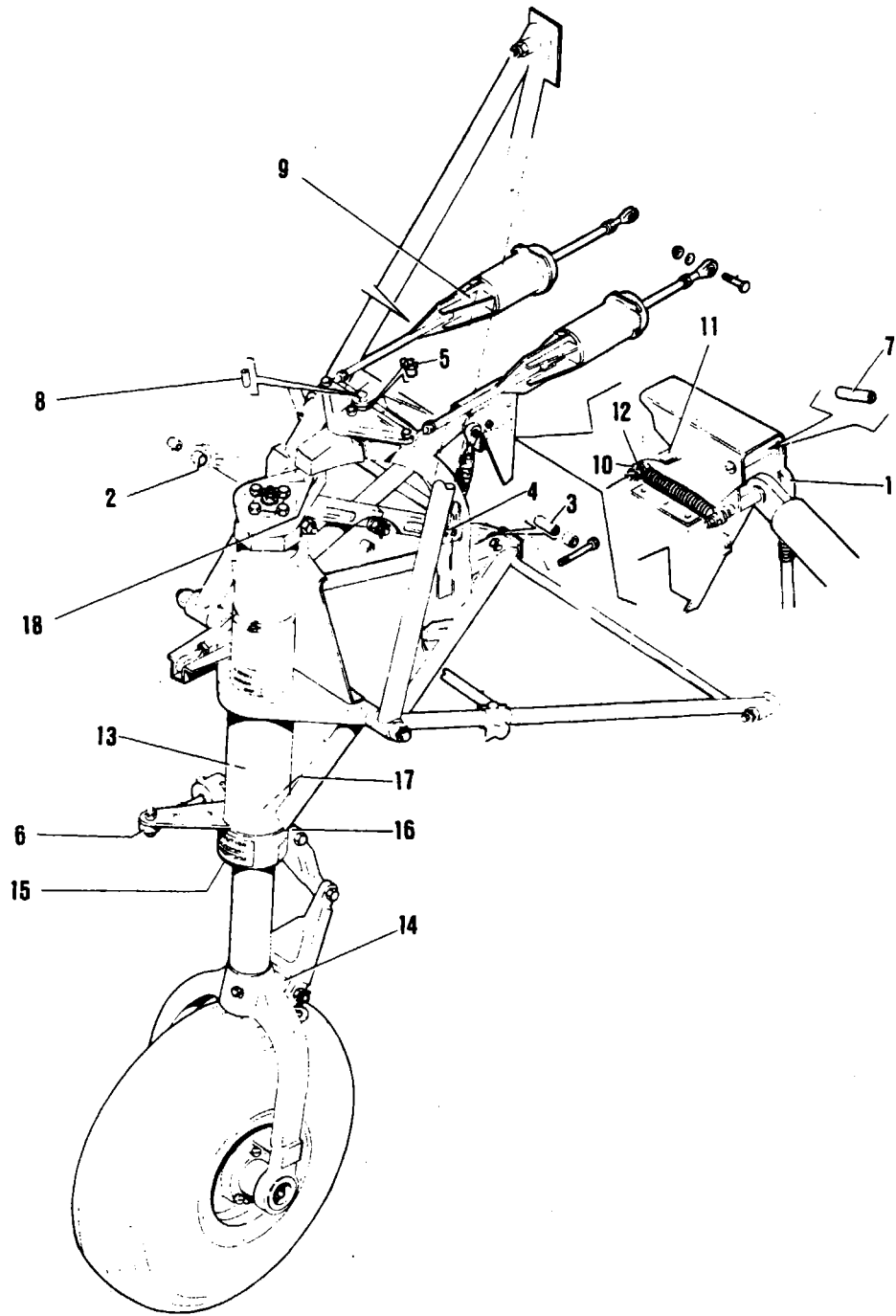

Figure 7-1A. Nose Gear Service Tolerances

Added: 3/16/81

1J11

LANDING GEAR AND BRAKE SYSTEM

PIPER SENECA II SERVICE MANUAL

TABLE VII-I. NOSE GEAR SERVICE TOLERANCES

No.	Part No.	Nomenclature	Manufacturer's Dimension	Service Dimension	Tolerances	Remarks
1	452-334 PS10020-1-6RX	Downlock Link Rod End Bearing	Bolt Hole: .1900 +.0015 -.0005		—	
2	95061-29	Bushing	.439 .440		.004	
3	95061-30	Bushing	.312 .311		.002	
4	95061-31	Bushing	.193 .189		.005	
5	452-540 FF520-10	Steering Arm Flange Bng.	.3765 .3755	.002	.002	Press Fit
6	452-552 PS10020-2-3RT	Centering Spring Bearing	Bolt Hole: .2500 +.0015 -.0005		.001	
7	95061-89	Bushing	.189		.004	
8	95061-28	Bushing	.252 .250		.004	
9	452-334 PS10020-1-6RX	Bungee Bearing	Bolt Hole: .1900 +.0015 -.0005			
10	95061-20	Bushing	O.D. 312 x .058		.004	
11	95061-24	Bushing	O.D. .312 x .058		.004	
12	95061-25	Bushing	O.D. 312 x .058		.004	
13	95715	Upper Strut Tube Bearing	1.752 1.750		.004	
14	67026-07	Bushing	.313 .314	.313 .315	.002	Wet Zinc Chromate, Press Fit and Line Ream
15	67758-00	Trunnion Assembly Bushing	2.816 2.815		.002	

Added: 3/16/81

PIPER SENECA II SERVICE MANUAL

TABLE VII-I. SERVICE TOLERANCE (cont.)

No.	Part No.	Nomenclature	Manufacturer's Dimension	Service Dimension	Tolerances	Remarks
16	452-448 FF411-4	Upper Strut Tube Bearing	.313 .312		.002	Line Ream
17	452-331 FF310-3	Upper Strut Tube Bng	.376 .375		.002	
18	95061-27	Tiller Bushing	.252 .250		.004	

Added: 3/16/81

1J13

LANDING GEAR AND BRAKE SYSTEM

1J14
INTENTIONALLY LEFT BLANK

PIPER SENECA II SERVICE MANUAL

7-8. ASSEMBLY OF NOSE GEAR OLEO. (Refer to Figure 7-1.) After cleaning and inspecting components as explained in paragraph 7-7 above, reassemble the nose gear oleo As follows:

- a. Insert piston strut (30) into its recess in fork (39) and secure in position with hardware (38).
- b. Install snap ring (37) and washer (36) on piston strut.
- c. Install O-rings (31 and 34) and a new wiper ring (35) on bearing (32).
- d. Lubricate piston strut using hydraulic fluid (MIL-H-5606) and slide bearing onto piston strut.
- e. Slide spacer (29) onto strut and align holes. Insert two retaining pins (28).
- f. Lubricate inner walls of oleo cylinder with hydraulic fluid. Carefully insert piston strut into cylinder far enough to permit positioning of washer (36) and snap ring (37). (Refer to paragraph b above.)
- g. Install torque links (33) using appropriate hardware.
- h. Remove upper and lower shoulder bushings (17 and 22) from trunnion assembly (23).

NOTE

Avoid damaging the upper and lower flanges of the bushing.

- i. Slide the lower shoulder bushing down the oleo cylinder until it bottoms above mounting lug securing the upper torque link.
- j. Insert the oleo cylinder into the trunnion assembly (23). The base of the trunnion must seat firmly on the lower shoulder bushing.
- k. Carefully insert the upper shoulder bushing (17) between the oleo cylinder and the trunnion.
- l. Place O-ring (25) into recess in top of oleo cylinder. Position bearing (21) on oleo cylinder. The tab of the bearing should be facing forward. Insert the bottom of the tiller (20) into the opening in the top of the oleo cylinder and secure in position with four bolts and washer (1) and safety.
- m. Install nose gear centering spring assembly (11). (See latest revision of Piper Service Bulletin 893.)

NOTE

Ascertain that bolt is installed with the head down and washers are arranged as shown in Figure 7-1.

- n. Lubricate gear assembly. (Refer to Lubrication Chart, Section II.)
- o. Compress and extend the strut several times to determine the strut will operate freely. The weight of the tire and fork should allow the strut to extend.
- p. Install the air valve body (15), core (14) and cap (13) after servicing the oleo cylinder with oil and air. (Refer to Oleo Struts, Section II.)
- q. Check main gear for alignment (refer to paragraph 7-25) and operation.

7-9. REMOVAL OF NOSE LANDING GEAR. (Refer to Figure 7-2.)

NOTE

To gain access to the landing gear, remove access panels located in the forward baggage compartment.

- a. Place airplane on jacks.
- b. Disconnect leads to landing lights.
- c. Retract the landing gear far enough to permit unlocking the downlock mechanism.
- d. Disconnect downlock spring (44) from aft end of gear actuating cylinder (39).
- e. Disconnect upper drag link (32) from the strut housing.
- f. Disconnect the actuating cylinder from the strut housing.

PIPER SENECA II SERVICE MANUAL

1952

1. ROD ASSEMBLY - NOSE WHEEL CONTROL
2. BOOT
3. ARM ASSEMBLY - STEERING
4. CHANNEL ASSEMBLY - STEERING
5. TILLER ASSEMBLY
6. CLAMP
7. BOLT, WASHER, NUT & COTTER PIN
8. TUBE ASSEMBLY - NOSE GEAR DOOR ACTUATION
9. STOP ASSEMBLY
10. LINK - UPPER

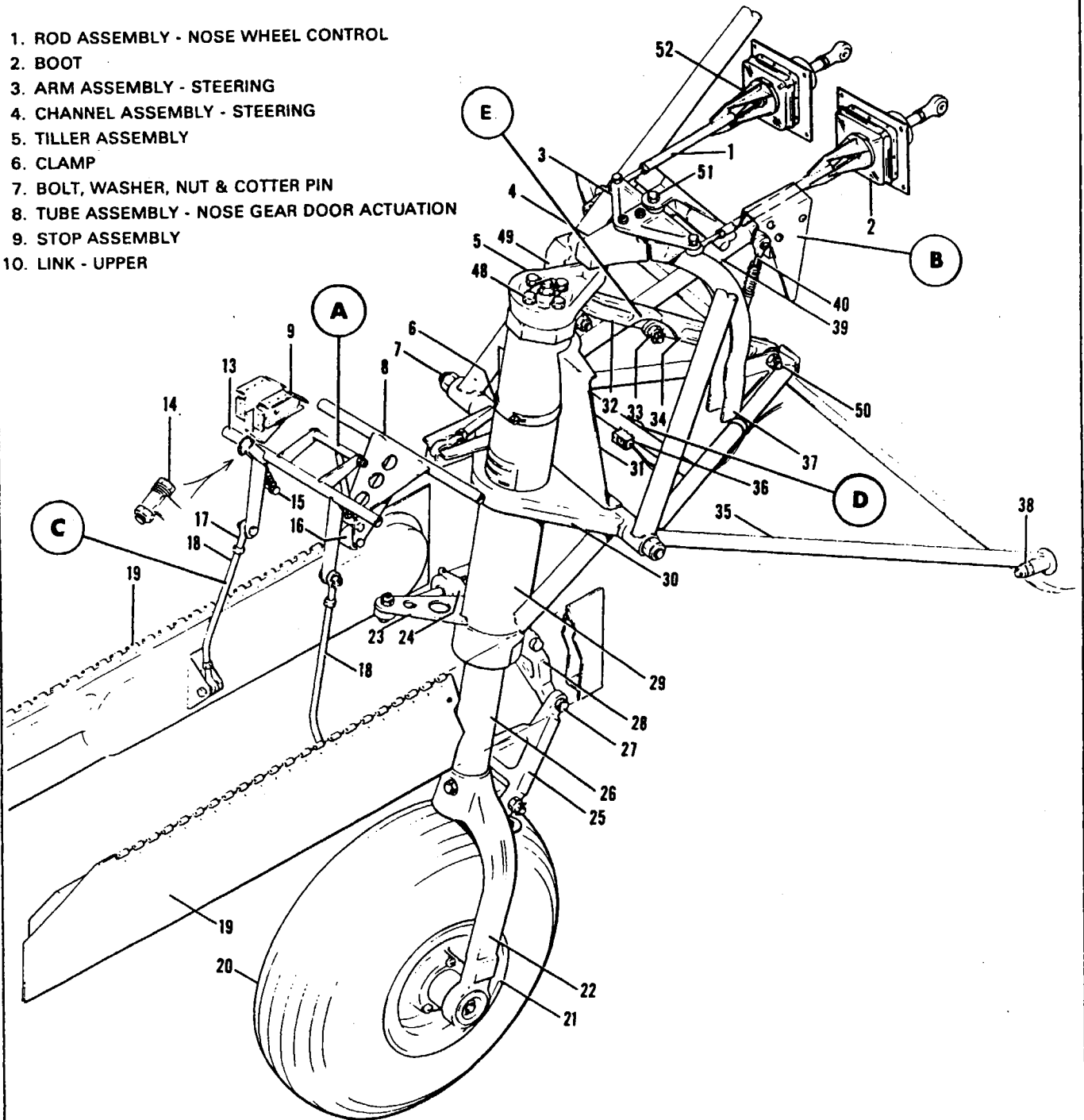

Figure 7-2. Nose Gear Installation

Revised: 8/10/80

1J16

LANDING GEAR AND BRAKE SYSTEM

Island Enterprises

PIPER SENECA II SERVICE MANUAL

- 11. LINK - LOWER
- 12. JAM NUT
- 13. TUBE ASSEMBLY — NOSE GEAR DOOR ACTUATION
- 14. BOLT, WASHERS & NUT
- 15. SPRING
- 16. ROLLER
- 17. ROD END BEARING
- 18. ROD ASSEMBLY
- 19. GEAR DOOR
- 20. TIRE
- 21. WHEEL
- 22. FORK
- 23. BEARING
- 24. SPRING ASSEMBLY - GEAR CENTERING
- 25. LINK - LOWER
- 26. ROD - PISTON
- 27. BOLT, WASHER & NUT
- 28. LINK - UPPER
- 29. HOUSING - STRUT
- 30. TRUNNION
- 31. PANEL ASSEMBLY - ANTI-SPLASH
- 32. LINK ASSEMBLY - UPPER DRAG
- 33. BOLT, WASHER, NUT & COTTER PIN
- 34. LINK ASSEMBLY - LOWER DRAG
- 35. GEAR MOUNT
- 36. SWITCH - GEAR UP
- 37. TRACK ASSEMBLY - NOSE GEAR
- 38. BOLT, WASHER & NUT
- 39. HYDRAULIC ACTUATING CYLINDER
- 40. LINK ASSEMBLY - NOSE GEAR DOWNLOCK
- 41. ROD END BEARING
- 42. SPRING
- 43. BUSHING
- 44. SPRING
- 45. SWITCH - GEAR DOWN
- 46. BUSHING
- 47. MOUNT ASSEMBLY
- 48. BOLT & WASHER
- 49. AIR VALVE CAP & BODY
- 50. BOLT (AN5-16A), WASHER, BUSHING & NUT
- 51. BOLT, WASHER & NUT
- 52. BUNGEE ASSEMBLY
- 53. LINK ASSEMBLY
- 54. BOLT (AN7-35), BUSHING, WASHER & NUT
- 55. BOLT (NAS464-P6L21), WASHER & NUT

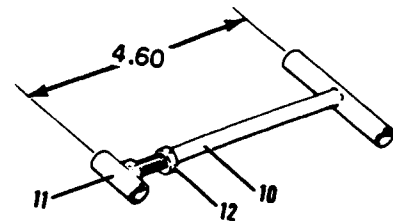

SKETCH A

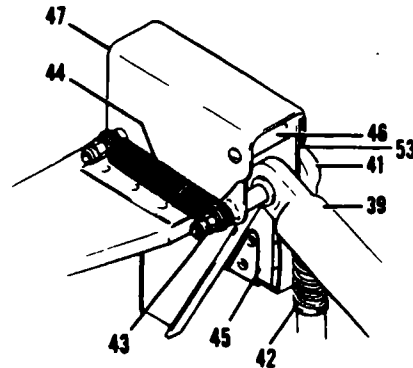

SKETCH B

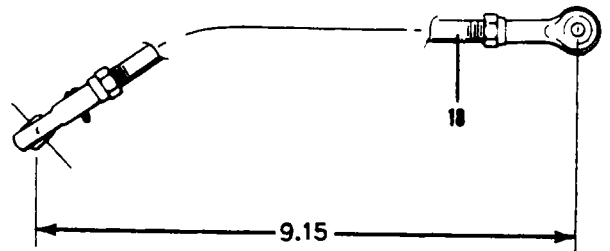

SKETCH C

A341

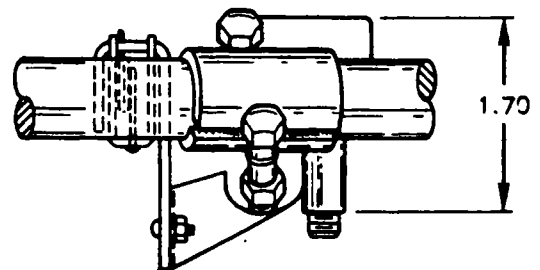

SKETCH D

Figure 7-2. Nose Gear Installation (cont.)

Revised: 8/10/80

1J17

LANDING GEAR AND BRAKE SYSTEM

PIPER SENECA II SERVICE MANUAL

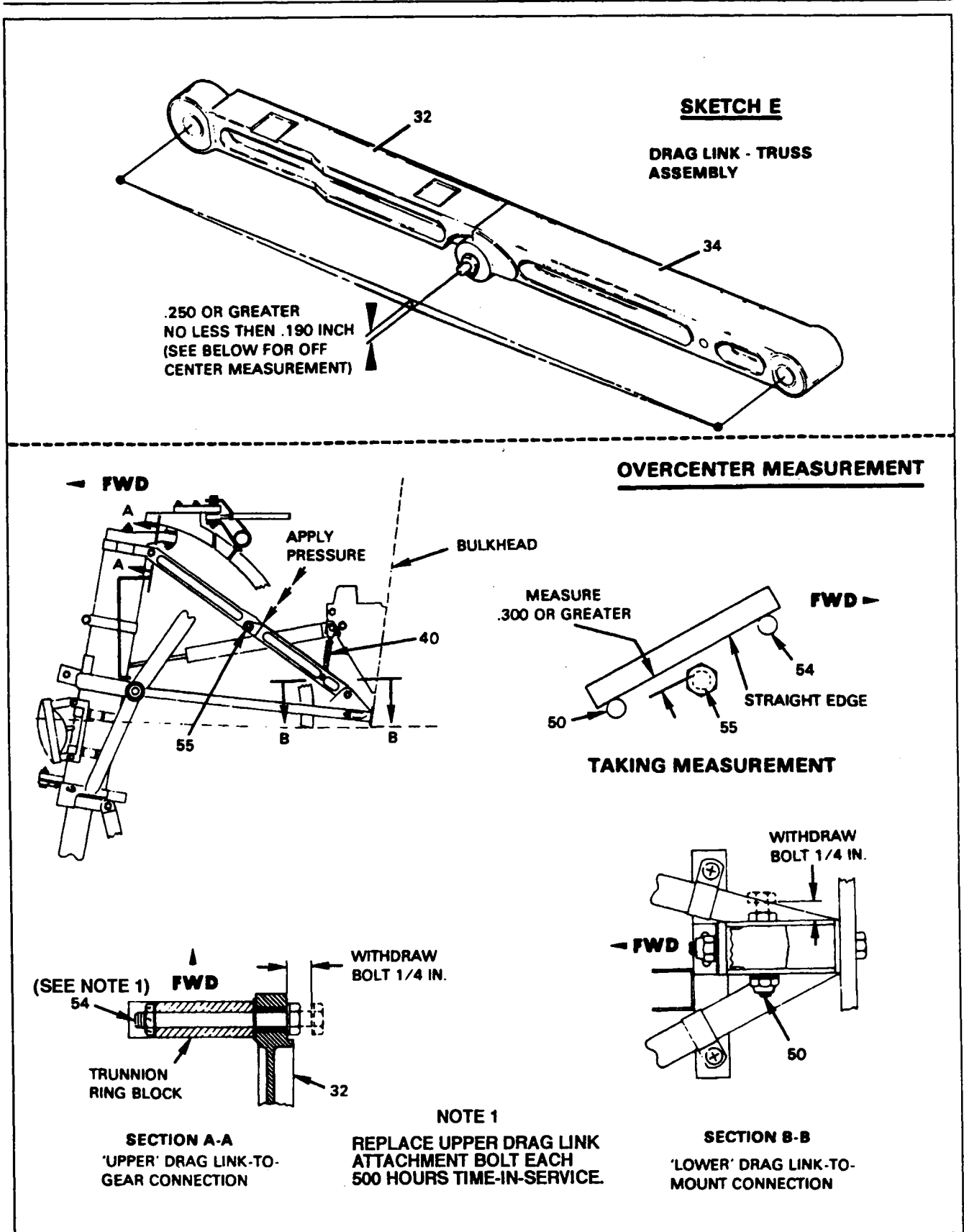

Figure 7-2. Nose Gear Installation (cont.)

Added: 8/10/80
 Interim Revision: 6/24/96

LANDING GEAR AND BRAKE SYSTEM

1J19
INTENTIONALLY LEFT BLANK

1J20
INTENTIONALLY LEFT BLANK

PIPER SENECA II SERVICE MANUAL

- g. Remove attaching hardware at strut housing pivot point and remove landing gear from the airplane.
- h. To remove upper and lower drag links (32, 34), disconnect downlock link (40) from lower drag link and disconnect lower drag link from its attachment point.

7-10. CLEANING, INSPECTION AND REPAIR OF NOSE LANDING GEAR.

- a. Clean all parts with a suitable dry type cleaning solvent.
- b. Inspect gear components for the following unfavorable conditions:
 - 1. Bolts, bearings and bushings for excessive wear, corrosion and damage.
 - 2. Gear strut and cylinder, drag links and downlock link assembly for cracks, dents, bends or misalignment.
 - 3. Downlock link assembly for damaged threads and bearing.
 - 4. Roller assembly for freedom of movement and excessive wobble.
- c. Check downlock spring and downlock link spring for excess wear and corrosion, particularly around the hook portion. Springs should be discarded if wear or corrosion exceeds one quarter the diameter of the spring. Remove corrosion and paint spring.
- d. Check downlock spring for adequate tension. This may be accomplished by observing several locking activations and checking for smooth operation with positive locking each time. If hook or down lock movement is slow or has a hesitation or jerky movement, the spring should be replaced. Check down lock link assembly for proper operation and cleanliness. Pin and hole should be carefully inspected for signs of wear and elongation.
- e. Check general condition of limit switches and actuators, wiring for fraying and poor connections or conditions which could lead to failure.
- f. Repairs to the landing gear are limited to reconditioning of parts such as smoothing out minor nicks and scratches, repainting areas where paint has chipped or peeled, and replacement of parts.

WARNING

DO NOT attempt to remove the spring from the shaft assembly of the nose gear centering spring assembly. This spring is held under compression by two bushings and two pins with fused heads.

7-11. INSTALLATION OF NOSE LANDING GEAR. (Refer to Figure 7-2.)

CAUTION

When assembling any units of the landing gear; lubricate bearings, bushings, and friction surfaces with the proper lubricant as described in Section II.

- a. Position the landing gear assembly into the gear mount assembly and ascertain that the tiller assembly is located in the slot of the steering arm assembly.
- b. Align the attachment points on the strut housing with the attachment points on the gear mount assembly.
- c. Install bolts, washers, and nuts, securing the strut to the mount. Tighten the nuts to a snug fit, yet allowing the gear to swing free, then install the cotter pins.
- d. The drag links, retraction cylinder, downlock link and downlock spring may be installed by the following procedure:
 - 1. Ascertain that the upper and lower drag links are assembled.

CAUTION

Upper drag link AN7-35 attachment bolt must be replaced each 500 hours time-in-service.

- 2. Position the drag link assembly with the contact surfaces up, to allow the bolt holes in the links to align with the bolt holes in the strut housing and gear mount assembly. Install the link attachment bolts.
- 3. Install washers and nuts on the drag link attachment bolts. Tighten the nuts, yet allow the links to operate freely.

PIPER SENECA II SERVICE MANUAL

4. Position the landing gear in the downlocked position and ascertain that the drag links are fully extended and over center when the stop surfaces make contact.
5. Adjust the rod end of the retracting cylinder so that a 0.25 of an inch of rod travel remains before full extension with the gear down.
6. Connect the retraction cylinder rod end to the strut housing and secure with bolt, washers and nut.
7. Connect the downlock link to the lower drag link and the downlock spring to the link assembly.
8. Adjust the downlock link so it is fully compressed when the gear is down and locked. On airplanes equipped with an up stop, ascertain that the three pivot points in the downlock link assembly (41) and the link assembly (53) are aligned.

NOTE

The downlock link assembly will move aft slightly with the remainder of the cylinder travel until the link contacts the stop. At this position, the downlock light switch must actuate.

9. Install spring (44) in position on link (53) with drag link assembly fully extended (over center with upper faces in solid contact). Adjust the linkage (40) to a fully retracted position and install.

NOTE

The link (40) is fully retracted when the guide pin is bottomed out at the slot.

Free fall the nose gear a minimum of 3 times. Remove linkage (40) and readjust per Note. Shorten linkage by one-half turn clockwise and reinstall.

10. With the following procedure check the drag links for proper "through center" travel. (Refer to Figure 7-2, Sketch E.) Should the distance not meet the required through center travel as follows, notify Vero Beach Customer Service immediately. **DO NOT RETURN AIRCRAFT TO SERVICE.**

- (a) Unbolt the downlock link assembly from the lower drag link, and with the downlock link rotated up out of the way, tape the link to the bulkhead.
- (b) Without removing the bolts, loosen the retaining hardware of the three drag link bolts (50, 54, 55) and withdraw them until about 1/4 inch of grip is visible. **DO NOT REMOVE BOLTS.**
- (c) Lay a "true" straightedge across the exposed grip of the upper and lower drag link bolts (50, 54). Refer to "Drag Link Measurement," Sketch E, Figure 7-2, for a guide.
- (d) Apply pressure to the top of the drag links insuring the upper faces of the drag links are in solid contact, and measure the perpendicular distance between the top surface of the NAS 464-26L21(55) bolt grip and the bottom of the straightedge.
- (e) The distance measured should be .300 inch or greater. If the measured distance is between .300 and $.245 \pm .005$, the Customer Service representative should be notified and return the aircraft to service. However, if the measured distance is less than .240 inch, **DO NOT** return the aircraft to service, and notify Vero Beach Customer Service.

- e. Rig the nose gear centering spring so that the nose gear has full left and right travel against its stops. Use a tow bar to reach full travel.
- f. Set the up stop to the dimension shown in Figure 7-2, Sketch D. Retract the gear and if necessary, readjust the stop to locate the nose gear in the proper retracted position.

NOTE

When stop adjustments are made, cycle the gear to insure that the nose gear strut engages the stop under retraction pressure.

- g. Retract the nose gear and check the up limit switch for actuation.
- h. With the nose gear in the retracted position, adjust the up switch until switch is actuated. Move switch upward another .02 to .04 inches. Adjust the rod end of the retraction cylinder to allow a minimum of .06 inches of actuator travel remaining in the retracted position.
- i. Cycle the gear fully while checking switch actuation, downlock action, and up stop action to include short pickup cycles simulating in flight gear sag pickup. Check the actuator travel left to full extension in the down and locked position. A minimum of .15 inches must remain. Check the up switch override action to insure the proper operation.
- j. Let the gear free fall to determine that the downlock spring returns the body end of the retraction cylinder aft so the downlock link assembly is fully compressed and the drag link arms are over center.
- k. With the nose gear turned full left and right against the stops, check and if necessary, adjust the clearance between the steering horn and track. Maximum clearance is 0.06 and minimum clearance is 0.03.
- l. Refer to Paragraph 7-16 for rigging of nose gear doors.
- m. Ascertain that the gear is lubricated per lubrication chart, Section II.
- n. Check the alignment of the nose gear per Paragraph 7-12. Ascertain that gear is down and locked.
- o. Remove the airplane from jacks.

1J24
INTENTIONALLY LEFT BLANK

7-12. ALIGNMENT OF NOSE LANDING GEAR.

- a. Park the airplane on a smooth level floor which will accommodate the striking of a chalk line.
- b. Place airplane on jacks and level airplane laterally and longitudinally. (Refer to Leveling, Section II.)
- c. Extend a plumb bob from the center of the tail skid and mark the contact point on the floor.
- d. Extend a chalk line from the mark on the floor below the tail skid to point approximately three feet forward of the nose wheel. Allow the chalk line to pass under the wheel at the centerline of the tire. Snap the chalk line.
- e. Clamp rudder pedals to align in a lateral position. (Refer to Figure 7-3.)
- f. Adjust the rod end bearings of each steering bungee to align the nose wheel with the chalk line and to bring the rudder pedals into neutral angle fore and aft. There should be no load on the bungee springs. This condition exists when the overall measurement taken between the facing sides of the washers at each rod end of the bungee is 13.71 inches. To align the nose wheel straight forward, stand in front of the nose gear and align the center rib of the tire with the chalk line or lay a straightedge along the side of the tire and parallel with the chalk line. In neutral position, the rudder pedals are tilted aft as shown in Figure 7-4, with the airplane level. Place a bubble protractor against a steering tube to check this angle. One end of each steering bungee must be disconnected and the jam nuts loosened to make this adjustment; do not attempt to make the complete adjustment by means of one bearing, but divide the adjustment between the bearings at each end of each rod. Check that the rod ends have sufficient thread engagement by determining that a wire will not go through the check hole in the rod. Reinstall bungees, tighten and safety the jam nuts.
- g. To check the nose gear steering for its correct degree of maximum travel, right and left (see Table II-III), use the wheel pivot point as the center point and draw a line at the travel degree angle on each side of the chalked centerline. Use a tow bar to turn the nose gear full travel left and right and overcome the bungee system. Should travel in one direction be excessive and not enough in the other, check the steering arm and steering bungees for damage. Refer to Servicing Steering Bungees, Section II for lubrication instructions of the bungee assemblies.

7-13. REMOVAL OF NOSE GEAR DOOR ASSEMBLY. (Refer to Figure 7-2.)

- a. With nose gear extended, disconnect door retraction rods (18) from doors (19) by removing attaching hardware.
- b. To remove doors, straighten bent end of hinge pins and pull the pins out from the opposite end.
- c. Disconnect spring (15) from arm of upper nose gear actuating tube assembly (13).
- d. Disconnect link assembly (10) from the upper nose gear actuating tube (13) and remove lower nose gear actuating tube assembly (8) with roller attached.
- e. Remove upper actuating tube assembly (13).

7-14. CLEANING, INSPECTION AND REPAIR OF NOSE GEAR DOOR ASSEMBLY.

- a. Clean all components with a suitable cleaning solvent.
- b. Inspect doors for damage, loose or damaged hinges and brackets.
- c. Inspect retraction rods for damage and rod end bearings for corrosion.
- d. Check door tension spring for wear and tension below minimum allowable tolerance. Reject spring if load tension is below 12 ± 2 pounds with spring extended to 4.1 inches.
- e. Check general condition of actuating tube assemblies and roller assembly.
- f. Repairs to doors are limited to replacing hinges and brackets.
- g. Repairs to the retraction mechanism are limited to painting and replacement of component parts.

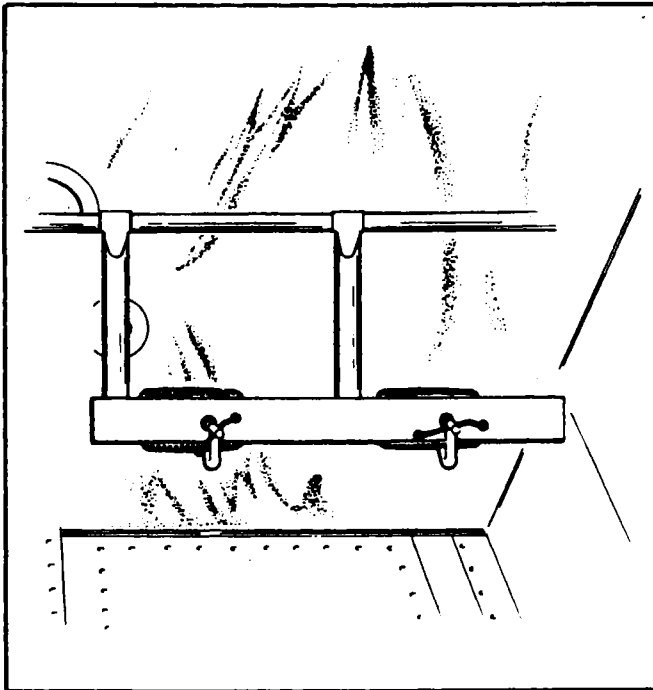

Figure 7-3. Clamping Rudder Pedals in Neutral Position

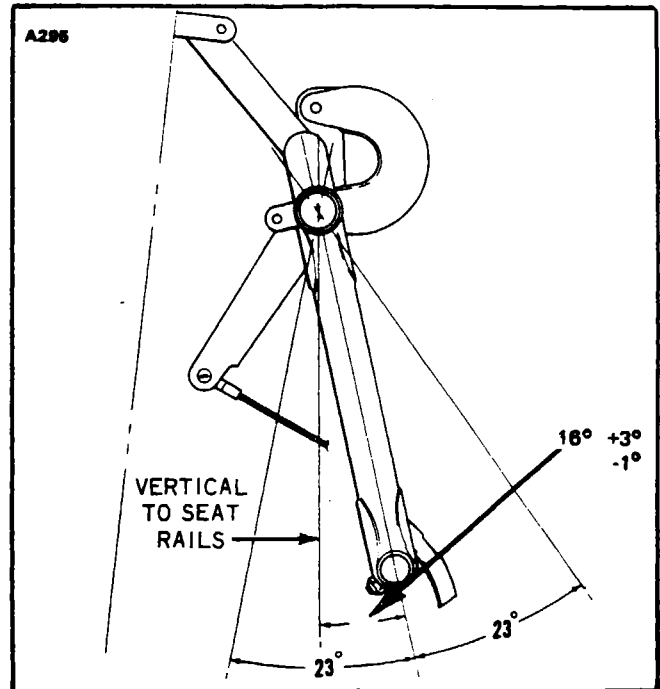

Figure 7-4. Rudder Pedals at Neutral Angle

7-15. INSTALLATION OF NOSE GEAR DOOR ASSEMBLY. (Refer to Figure 7-2.)

- a. Install upper nose gear actuating tube assembly (13) in position between two bearing blocks and secure with attaching hardware.
- b. Install lower nose gear actuating tube assembly (8) in position between two bearing blocks and secure with attaching hardware.
- c. Insert lower link assembly (11) into upper link assembly (10) and adjust as necessary to obtain a dimension of 4.60 inches between the centerline of each link. Tighten locknut. (Refer to Sketch A.)
- d. Install assembled link assembly between two upright arms of upper actuating tube assembly and secure with attaching hardware. Insert the lower link between the two upper holes in actuating tube assembly (8) and secure with attaching hardware. (Refer to Figure 7-2.)
- e. Install roller (16) directly below link (11) on lower actuation tube assembly. Secure in position with attaching hardware making certain the roller is free to turn.

NOTE

If cracks or any signs of wear are evident, the roller must be replaced.

- f. Install four washers on stop bolt (14) and insert into bushing on upper actuating tube assembly (13).
- g. Adjust both retraction rods (18) to obtain a dimension of 9.15 inches as shown. Attach upper end of retraction rod to arm of upper actuation tube assembly. The lower end should be attached to the door bracket. Install tension spring (15). (Refer to Figure 7-2.)
- h. Install gear doors by positioning hinge halves and inserting hinge pin. A new hinge pin should be used. Bend end of hinge pin to secure door in place.

7-16. ADJUSTMENT OF NOSE GEAR DOOR.

- a. Place airplane on jacks.
- b. With link assembly and retraction rods adjusted as explained in Paragraph 7-15, the gear should swing through the door opening with a clearance of .25 inch between the gear and door at their closest point.
- c. If clearance between gear and door is less than .25 inch, remove washers from stop bolt until the specified clearance is obtained. If clearance between the gear and door exceed the specified clearance, add washers to the stop bolt.
- d. If doors sag when fully retracted, tighten link assembly (11, Figure 7-2). If doors are too tight, loosen link assembly.
- e. Check all rod ends for adequate thread engagement for safety and tightness of jam nuts.

7-17. MAIN LANDING GEAR SYSTEM.

7-18. DISASSEMBLY OF MAIN GEAR OLEO. (Refer to Figure 7-5.) The main gear oleo assembly may be removed and disassembled from the gear oleo housing with the gear removed from or installed in the airplane.

- a. Place airplane on jacks.
- b. Place a drip pan under the main gear to catch spillage.
- c. Remove air and fluid from the oleo. Depress air valve core pin until strut pressure has diminished; remove the filler plug and with a thin hose siphon as much hydraulic fluid from the strut as possible.
- d. Disconnect brake line at the joint located in the wheel well.
- e. To remove piston tube assembly (25) from oleo housing (11), remove the upper and lower torque link connecting bolt assembly (3) and separate links. Note number and thickness of spacer washer(s) between the two links (15 and 16).
- f. Compress the piston tube (25); reach up into the tube and release the snap ring (24) from the annular slot at the bottom of the oleo housing.
- g. Pull piston tube (25) with component parts from cylinder housing.
- h. The piston tube (25) components may be removed by reaching in the tube and pushing out the upper bearing retainer pins (17). Slide off the upper bearing (18), lower bearing (20) with O-rings (19 and 20), wiper (22) and washer (23).
- i. To remove orifice tube (12) from the oleo housing, remove locknut (6) and washer (7) from top of housing. Draw tube with O-ring (9) and retainer (8) from housing.
- j. The orifice plate (13) is removed from the bottom of orifice tube (12) by releasing snap ring (14) holding the plate in position.
- k. To remove piston tube plug (26) and O-ring (27) located in the bottom end of the tube, remove bolt assembly (29) and insert a rod up through the hole in the body of the fork (28) and push plug with O-ring from top of tube.

7-19. CLEANING, INSPECTION AND REPAIR OF MAIN GEAR OLEO.

- a. Clean all parts with a suitable dry type cleaning solvent.
- b. Inspect landing gear oleo assembly components for the following:
 1. Bearings and bushings for excess wear, corrosion, scratches and overall damage.
 2. Retaining pins for wear and damage.
 3. Lock rings for cracks, burrs, etc.
 4. Cylinder and orifice tube for corrosion, scratches, nicks and excess wear.
 5. Orifice plate for hole restriction.
 6. Fork tube for corrosion, scratches, nicks, dents and misalignment.
 7. Air valve general condition.
- c. Repair of the oleo is limited to smoothing out minor scratches, nicks and dents and replacement of parts.

2025

1. BRACKET, SWITCH ACTUATOR
2. BOLT, WASHERS, NUT AND COTTER PIN
3. BOLT, WASHERS, NUT AND COTTER PIN
4. BOLT, WASHERS, NUT AND COTTER PIN
5. AXLE NUT
6. NUT
7. WASHER
8. RETAINER
9. O-RING
10. VALVE ASSEMBLY
11. HOUSING, OLEO STRUT
12. ORIFICE TUBE
13. PLATE, ORIFICE
14. SNAP RING
15. LINK ASSEMBLY, UPPER
16. LINK ASSEMBLY, LOWER
17. RETAINER PIN, BEARING
18. BEARING, UPPER
19. O-RING, OUTER
20. BEARING, LOWER
21. O-RING, INNER
22. WIPER STRIP
23. WASHER
24. SNAP RING
25. PISTON TUBE
26. PLUG
27. O-RING
28. FORK ASSEMBLY
29. BOLT ASSEMBLY
30. BRACKET - SQUAT SWITCH
31. PLATE, SPRING ATTACHMENT
32. PISTON RING

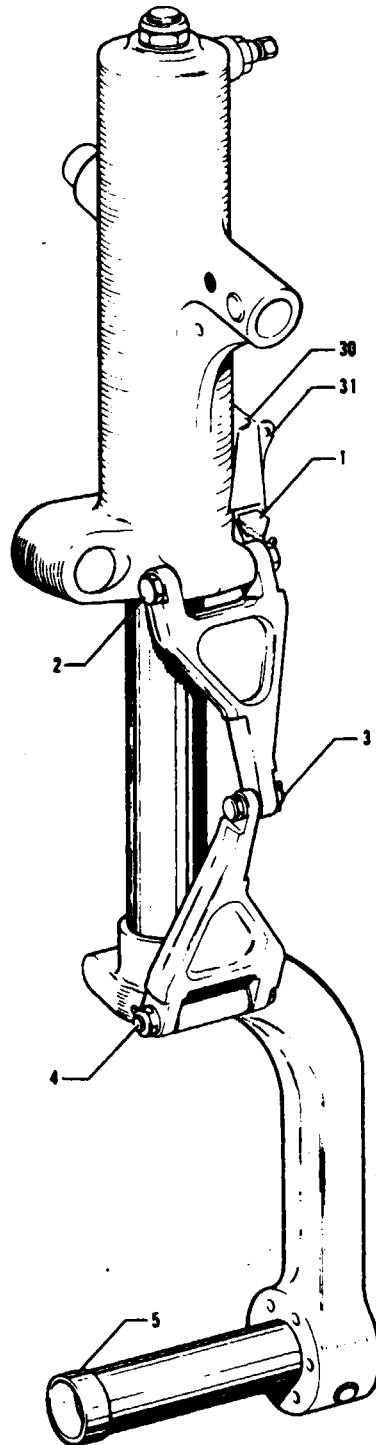

Figure 7-5. Main Gear Oleo Strut Assembly

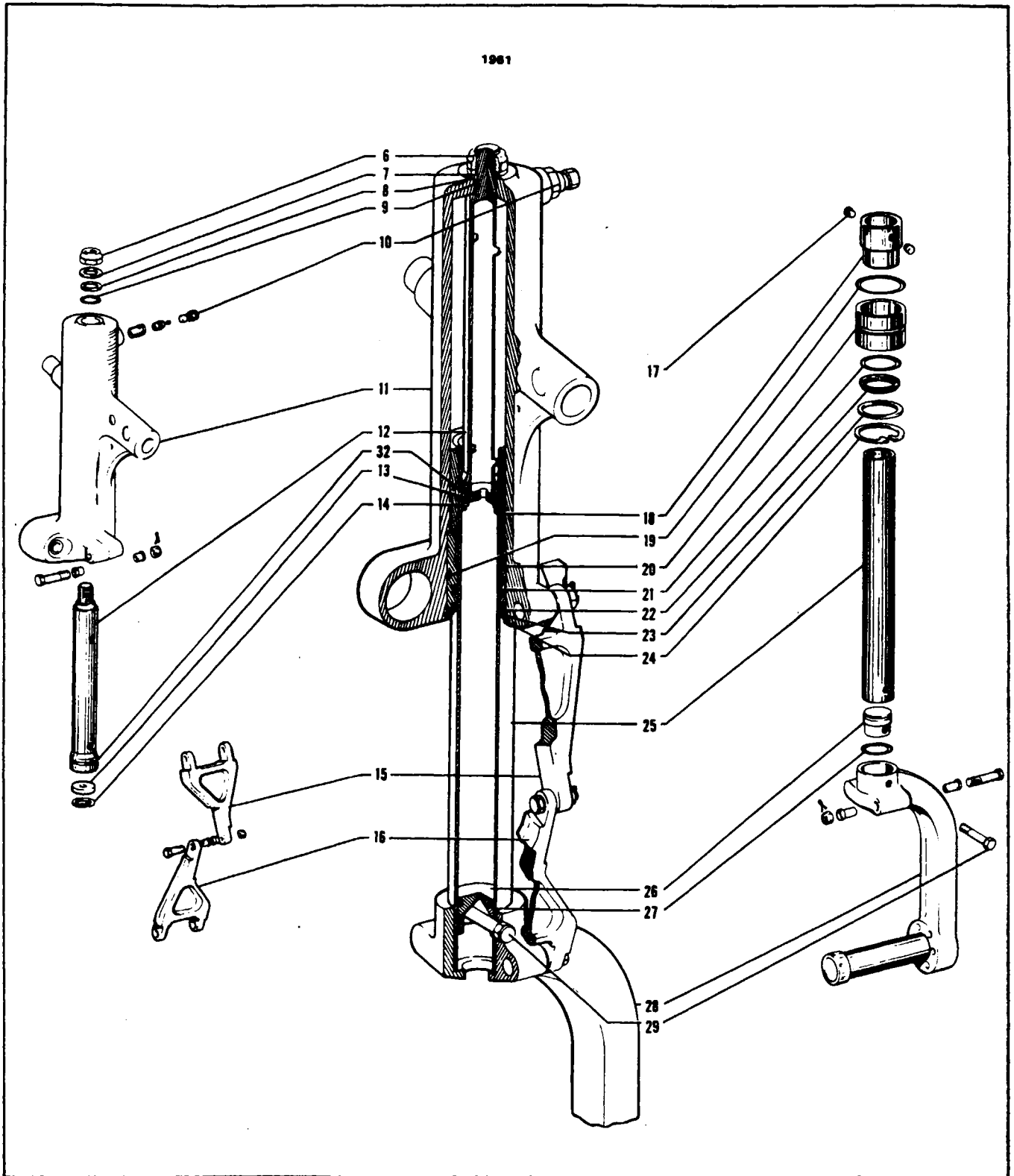

Figure 7-5. Main Gear Oleo Strut Assembly (cont.)

Reissued: 10/11/79

1K5

LANDING GEAR AND BRAKE SYSTEM

3186

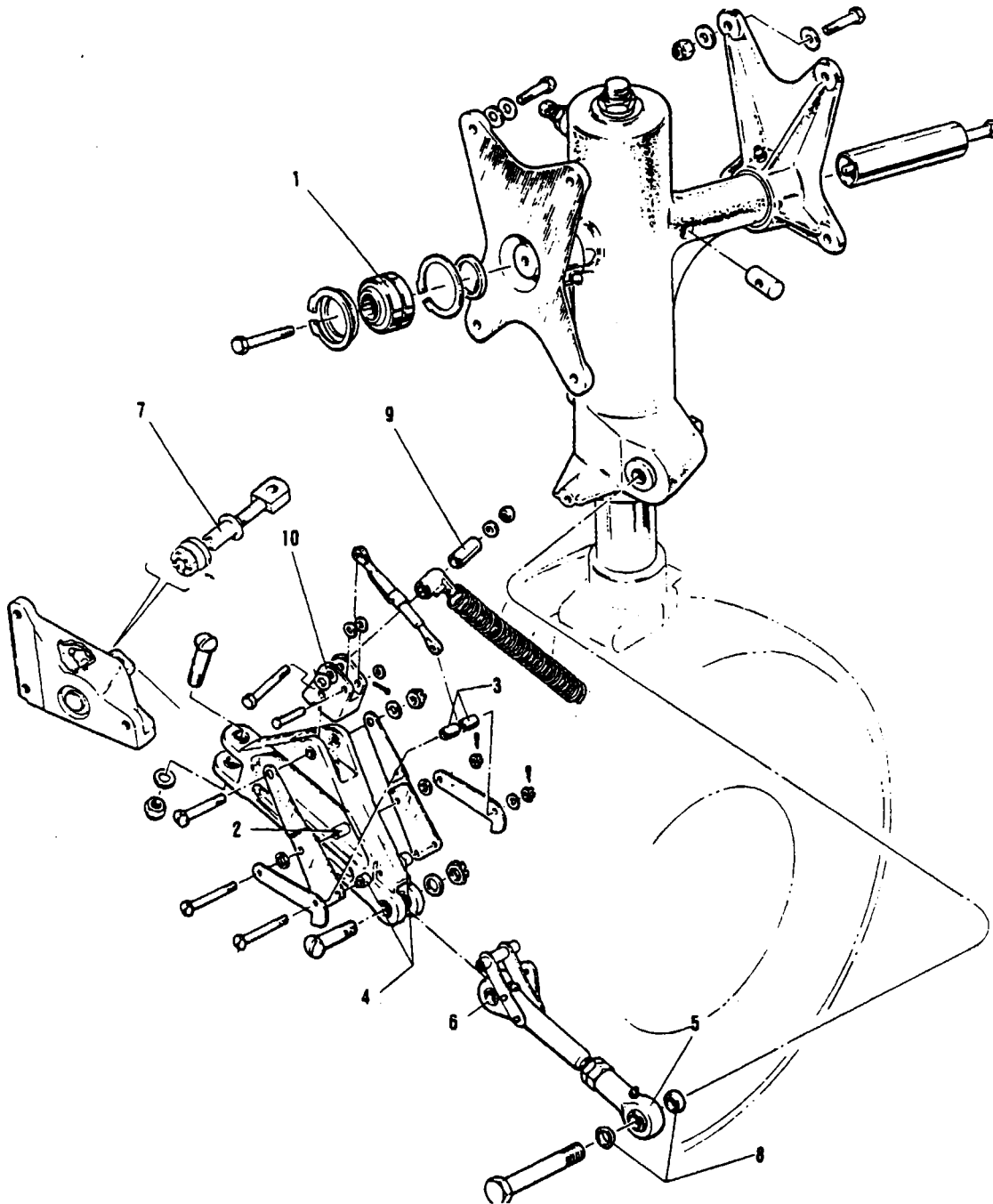

Figure 7-5a. Main Gear Service Tolerances

Added: 3/16/81

1K6

LANDING GEAR AND BRAKE SYSTEM

Island Enterprises

PIPER SENECA II SERVICE MANUAL

TABLE VII-II. MAIN GEAR SERVICE TOLERANCES

No.	Part No.	Nomenclature	Manufacturer's Dimension	Service Dimension	Tolerances	Remarks
1	452 575 PS10020-10-2	Spherical Bearing	.9995 1.0000		None	
2	63900-88	.312 x .058			.004	No longer used
3	63900-130	Main Gear Truss Bushing	.250 x .028		.004	
4	14175-103	Main Gear Truss Assy. Bushing	.161		0	No Rotation
5	452 368 (HFX 8G)	Rod End Lower Side Brace Link	.50 +.0015 -.0005 or	.50 +.003 -.0005	.0035	34-7670324 and below
	78722-02	Rod End Lower Side Brace Link				34-7670325 and above
6	65003-44	Lower Side Brace Link Bushing	.373 .375	.372 .376	.004	Line Ream Press Fit
7	67026-12	Bracket Bushing	.624 .625			
8	21822-00	Tapered Truss Assy. Bushing	.500 .510 or			34-760324 and below
	78716-02	Tapered Truss Assy. Bushing	.562 +.010 -.000			34-760325 and above
9	63900-85	Spring Attachment Bushing	.191	.189 .193	.004	
10	95061-64	Bushing	.250 x .028		.004	

Added: 3/16/81

1K7

LANDING GEAR AND BRAKE SYSTEM

7-20. ASSEMBLY OF MAIN GEAR OLEO. (Refer to Figure 7-5.)

- a. Determine that all parts are cleaned and inspected.
- b. To install the piston tube plug (26), first lubricate the plug O-ring (27) with hydraulic fluid (MIL-H-5606) and install it on the plug. Lubricate the inside wall of the tube. Insert the plug into the top of the tube (25) and push it to the fork end. Align the bolt holes of the fork, tube and plug, and install bolt assembly.
- c. If desired, cement a cork in the hole in the bottom of the fork body to prevent dirt from entering between the fork and tube.
- d. To assemble components of orifice tube (12), insert orifice plate (13) into the bottom of the tube and secure with snap ring (14).
- e. To install tube (12) in oleo housing (11), insert the tube up through the housing. With the end of the tube exposed through the top of the housing, install the O-ring (9), retainer (8), washer (7), and locknut (6). Tighten locknut only finger tight at this time.
- f. Assemble components of piston tube (25) on the tube by placing, in order, snap ring (24), washer (23), lower bearing (20) with outer and inner O-ring (19 and 21) and upper bearing (18). Align the two .125 diameter holes and the lock pin holes with the corresponding holes in the piston tube and install pins (17).
- g. Lubricate the wall of the cylinder oleo housing (11) and tube (25), and carefully insert the tube assembly into the housing, guiding the orifice tube (12) into the piston tube. Install the wiper strip (22), slide the washer (23) into position and secure the assembly with snap ring (24).
- h. Tighten locknut (6) at top of housing and torque to 300-500 inch pounds.
- i. Ascertain that the bushings are installed in the upper and lower torque links (15 and 16) and then install links. The torque link bolt assemblies (2, 3 and 4) should be lubricated and installed with the flat of the bolt head hex adjacent to the milled stop of the wide end of the link. (Use the same thickness of spacer washers between the two links as those removed to maintain correct wheel alignment.) Tighten the bolts only tight enough to allow no side play in the links, yet be free enough to rotate.

NOTE

Instructions contained in Paragraph "j" below pertain to left oleo strut assemblies only.

- j. Assemble squat switch actuator bracket (1) on bolt assembly (2). Insert a rivet through the hole provided in the bracket into the upper link and install the nut. Install squat switch bracket (30) immediately above the actuator bracket.
- k. Attach spring attachment plate (31) to the mounting lug on the base of the housing immediately above the upper link.
- l. Connect brake line and bleed the brakes per Paragraph 7-65 or 7-66.
- m. Lubricate gear assembly. (Refer to Lubrication Chart, Section II.)
- n. Compress and extend the strut several times to ascertain the strut will operate freely. The weight of the gear wheel and fork should allow the strut to extend.
- o. Service oleo strut with fluid and air. (Refer to Oleo Struts, Section II.)
- p. Check main gear alignment (refer to Paragraph 7-25) and gear operation. Ascertain that gear is down and locked.
- q. Remove the airplane from jacks.

7-21. REMOVAL OF MAIN LANDING GEAR. (Refer to Figure 7-6.)

- a. Place the airplane on jacks.
- b. The side brace link assembly may be removed by the following procedure:
 1. With gear in the extended position, disconnect gear downlock spring (18).
 2. Disconnect rod end (46) of actuating cylinder (24) from retraction fitting (21) on the upper side brace link (28) by removing nut, washer and bolt (47), and bushing and spring swivel (20).
 3. Disconnect lower side brace link (33) from gear housing (13) by removing attachment nut, washer and bolt (7). Note bushings on each side of end bearing.
 4. Disconnect upper side brace link (28) from side brace support fitting stud (26) by removing cotter pin, nut, washer and attachment bolt (25).
 5. The side brace support fitting may be removed by removing the cap bolts securing the fitting to the web of the spar.
 6. Remove the assembly, and further disassemble and inspect as needed.
- c. The strut housing (13) with components may be removed by the following procedure:
 1. Disconnect brake line (42) at its upper end in the wheel well.
 2. Disconnect gear door actuating rod (38) at the gear housing.
 3. Remove access plate located on underside of wing, aft of landing gear.
 4. If not previously disconnected, disconnect lower side brace link (33) from the gear housing.
 5. Disconnect forward support fitting (16) of housing (13) from the web of the main spar by removing fitting attachment bolts.
 6. Remove retainer tube (4) in aft support fitting (1) that supports the aft arm of the housing by reaching through the access opening on the underside of the wing, through the hole in the web and removing bolt (48) that secures the tube in the housing. Insert a hook through the bolt hole in the tube, and slide it aft from the support fitting. Remove the tube from the wing.
 7. Allow the gear to drop free from the wing.
 8. The aft support fitting (1) may be removed by holding the nuts in position, reaching through the access opening, and removing the fitting attachment bolts.
 9. The forward support fitting (16) may be removed from the arm of the housing by removing the bolt and washer from the base side of the fitting. Slide the fitting from the arm. Remove washer (52) from the arm.
- d. Either bearing (53 or 54) installed in the support fittings may be removed by removing the snap rings (2) that hold the bearing in the housing. Push the bearing from the housing.

7-22. CLEANING, INSPECTION AND REPAIR OF MAIN LANDING GEAR.

- a. Clean all parts with a suitable dry type cleaning solvent.
- b. Inspect the gear components for the following unfavorable conditions:
 1. Bolts, bearing and bushings for excess wear, corrosion and damage.
 2. Gear housing, side brace links, torque links and attachment plates for cracks, bends or misalignment.
 3. Downlock hook for excessive wear of the bearing surfaces.
- c. Inspect the gear downlock spring for the following:
 1. Excessive wear or corrosion, especially around the hook portion of the spring. A spring should be rejected if wear or corrosion exceeds one-quarter the diameter of the spring. Clean away all corrosion and repaint.
 2. Check the spring for load tensions below minimum allowable tolerance. The minimum tension of the spring is 48 pounds pull at 7.9 inches. Measurement is taken from the inner side of each hook.
- d. Check the general condition of each limit switch and its actuator, and wiring for fraying, poor connections or conditions that may lead to failures.

PIPER SENECA II SERVICE MANUAL

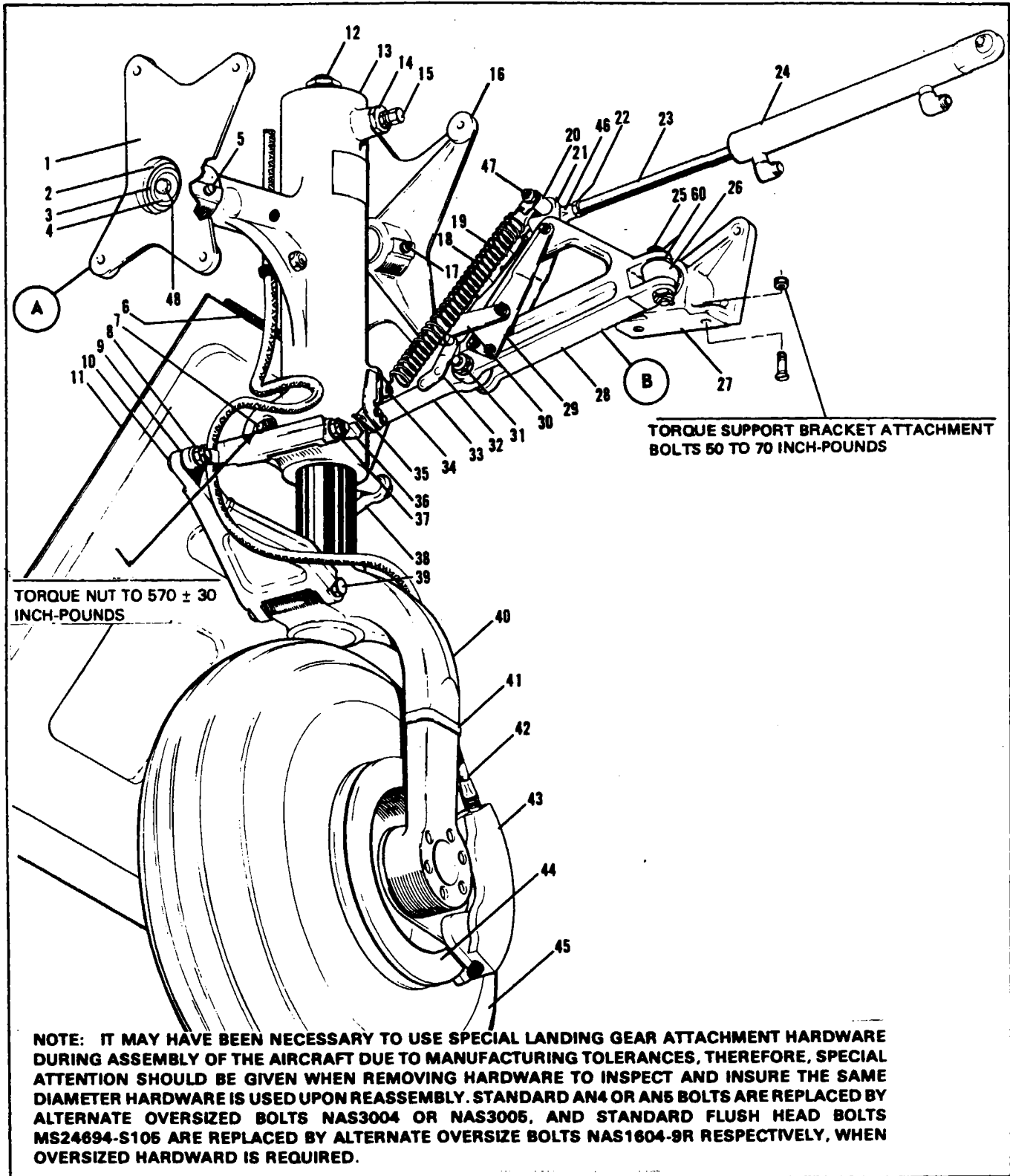

Figure 7-6. Main Gear Installation

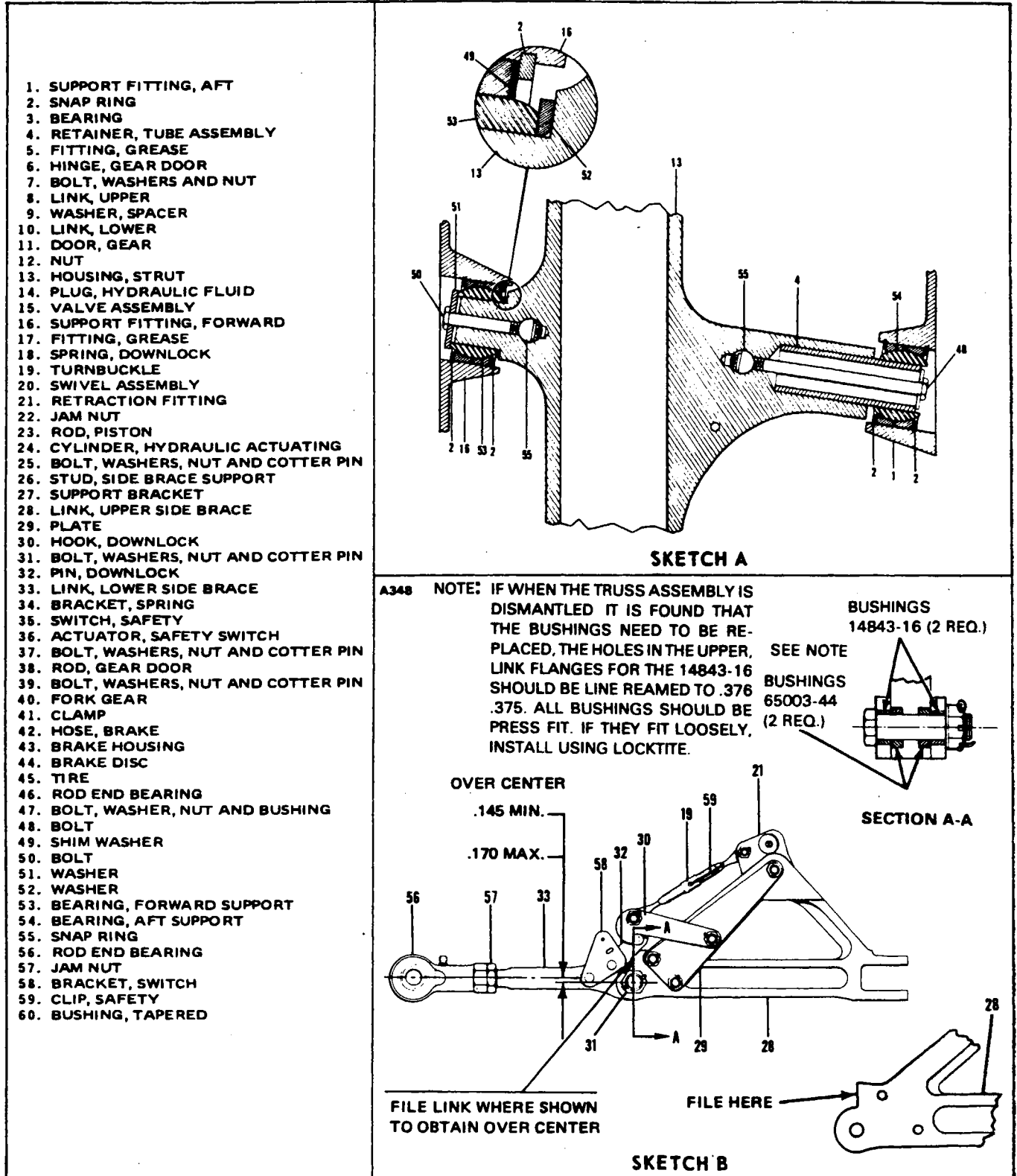

Figure 7-6. Main Gear Installation (cont.)

Revised: 8/10/80

1K11

LANDING GEAR AND BRAKE SYSTEM

e. Check side brace link through center travel by attaching the upper and lower links, setting them on a surface table, and ascertaining that when the stop surfaces of the two links touch, linkage is not less than .145 nor more than .170 of an inch through center. Should the distance exceed the required through center travel and bolt and bushings are tight, replace one or both links.

f. With side brace links assembled and checked, ascertain that when stop surfaces of the two links contact, the clearance between each downlock hook and the flat of the downlock pin is not less than 0.010 of an inch. Should clearance be less than that required, the hook only may be filed not to exceed a gap of more than 0.025 of an inch. The maximum allowable clearance between each hook and the downlock pin that are service worn is 0.055 of an inch. Should clearance be more than 0.055 of an inch, replace the pin, check clearance and then if still beyond tolerance, replace hooks. The gap between each hook should be equal.

g. Repair of the landing gear is limited to reconditioning of parts such as replacing components, bearings and bushings, smoothing out minor nicks and scratches and repainting areas where paint has chipped or peeled.

7-23. INSTALLATION OF MAIN LANDING GEAR. (Refer to Figure 7-6.)

NOTE

When assembling components of the landing gear, lubricate bearings, bushings, and friction surfaces with proper lubricant as described in Section II.

a. Insert a gear support bearing (53 and 54) in each support fitting (1 or 16) and secure with snap rings (2). Check bearing (53) for excess end play, shim as necessary with shim washers (49) (P/N 62833-44).

b. The gear housing may be installed in the wheel well of the wing by the following procedure:

1. Place spacer washer (52) and then forward support fitting (16) on forward arm of the housing. Determine that barrel nut (55) is properly positioned in the arm and insert attachment bolt (50) through washer (51) and the fitting into the arm. Tighten bolt and ascertain that the bearing is free to rotate.

2. Position aft support fitting (1) at its attachment point in the wheel well and secure with bolts, washers and nuts. Install nuts and washers by reaching through the access hole on the underside of the wing.

3. With the retainer tube (4) for the aft arm of the housing in hand, reach up through the access opening and insert the tube into the support fitting (1) through the hole in the web.

4. Position the gear housing up in the wheel well and install the forward support fitting (16) with bolts and washers. (One each AN960-416 and AN960-416L washer per bolt.)

5. Push the retainer tube into the arm of the housing and secure with bolt (48).

6. Check that the gear rotates freely in its support fittings and recheck thrust.

7. Connect the brake line to its mating line in the wheel well and bleed brakes as explained in Paragraph 7-65 or 7-66.

c. The gear side brace link assembly may be installed by the following procedure:

1. Position link support bracket (27) with swivel stud (26) installed at its attachment point on the web of the spar and secure with bolts and washers.

NOTE

When installing a new wing, it will be necessary to back drill two (2) holes 0.250 inch and countersink 100 x .499 through the spar cap. (Screw head should be flush with spar.) Use hole in the support bracket as a guide in the drilling.

2. Ascertain that the upper and lower links (28 and 33) are assembled with downlock hook (30), retraction fitting (21), etc., attached, and the through travel of the links and downlock hook clearance checked according to Paragraph 7-22.

3. Attach the upper link to the swivel stud of the support fitting and secure with bolt, bushing, washer, nut and cotter pin (25).

4. Attach lower link assembly (33) to the gear housing (13) and secure with bolt, washers and nut (7). Torque nut to 570 ± 30 inch-pounds.

5. The actuating cylinder rod end bearing (46) and lower side brace link (33) may be attached respectively to the retraction fitting (21) and strut housing during the adjustment of the landing gear.

d. Ascertain that the landing gear is lubricated per Lubrication Chart.

e. Check adjustment of landing gear per Paragraph 7-24.

f. Check alignment of the wheel per Paragraph 7-25.

g. Install the access plate on the underside of the wing and remove the airplane from jacks.

7-24. ADJUSTMENT OF MAIN LANDING GEAR.

a. Place the airplane on jacks.

b. Level the airplane laterally and longitudinally. (Refer to Leveling, Section II.)

c. Disconnect the gear door actuating rods at either the door or the housing, as desired, by removing the rod attachment bolt. Secure the door out of the way.

d. Adjust rod end on lower side brace link with no load on wheels, to obtain 89° angle between wheel centerline and level floor line on outboard side of gear.

e. Check that the rod end has sufficient thread engagement in the end bearing, align the flat sides of the bearing casting with the flat side of the bearing and tighten the jam nut.

f. Adjust the turnbuckle of the downlock mechanism by first ascertaining that the gear is down and locked, and then move the retraction fitting outboard until it contacts the stop slot of the side brace link. Hold the fitting in this position and turn the turnbuckle barrel until the downlock hooks make contact with the lock pin. Safety the turnbuckle.

g. For easier adjustment of the downlock limit switch, it may be set at this time as explained in Paragraph 7-34.

h. Retract and extend the gear manually several times to ascertain that the side brace link falls through center, the downlock hook falls into position and there is no binding of the gear assembly.

i. The gear should be adjusted in the up position to allow the gear fork to press lightly into the rubber bumper pad on the wing. The adjustment may be accomplished as follows:

NOTE

If it requires less than .125 of an inch to move the gear into the correct adjustment, Steps 2 and 6 thru 8 need only be followed.

1. Ascertain that the rod end bearing of the actuating cylinder is disconnected from the retraction fitting.

2. Actuate the hydraulic system to bring the hydraulic cylinder to the up position by turning the master switch on and moving the gear selector handle to the up position. The piston of the cylinder should be bottomed.

3. Raise the gear by pushing up on the retraction fitting, thus disengaging the hooks, and pushing up on the pivot point at the bottom of the side brace links to bring the links out of the locked position. Raise the gear until the fork presses lightly into the rubber pad. Retain the gear in this position.

4. Loosen the jam nut on the piston rod of the actuating cylinder and turn the rod end bearing in or out to allow a slip fit of the attachment bolt.
5. Install with the attachment bolt, bushing, spring swivel, and secure with washer and nut. Install the gear downlock spring.
6. When the gear is to within .125 of an inch of correct adjustment, the rod end need not be disconnected and therefore all that will be required is to loosen the jam nut, place a wrench on the flat at the end of the piston rod and turn to obtain correct adjustment.
7. Check the rod end bearing for adequate thread engagement and tighten jam nut.
8. If the downlock limit switch is properly adjusted, retract and extend the gear hydro-electrically to ascertain that the gear operates properly.

7-25. ALIGNMENT OF MAIN LANDING GEAR. (Refer to Figure 7-7.)

- a. Place a straightedge no less than twelve feet long across the front of both main landing gear wheels. Butt the straightedge against the tire at the hub level of the landing gear wheels. Jack the airplane up just high enough to obtain a six and one-half inch dimension between the centerline of the strut piston and the centerline of the center pivot bolt of the gear torque links. Devise a support to hold the straightedge in this position.
- b. Set a square against the straightedge and check to see if its outstanding leg bears on the front and rear side of the brake disc. (It may be necessary to remove the brake assembly to have clear access to the disc.) If it touches both forward and rear flange, the landing gear is correctly aligned. The toe-in for the main landing gear wheels is $0 \pm 1/2$ degrees.

NOTE

A carpenter's square, because of its especially long legs, is recommended for checking main landing gear wheel alignment.

- c. If the square contacts the rear side of the disc, leaving a gap between it and the front flange, the wheel is toed-out. If a gap appears at the rear flange, the wheel is toed-in.
- d. To rectify the toe-in and toe-out condition, remove the bolt connecting the upper and lower torque links and remove or add spacer washers to move the wheel in the desired direction. Refer to the chart on the following page.
- e. Should a condition exist that all spacer washers have been removed and it is still necessary to move the wheel further in or out, then it will be necessary to turn the torque link assembly over. (Refer to Figure 7-8). This will put the link connecting point on the opposite side allowing the use of spacers to go in the same direction.
- f. Recheck wheel alignment. If the alignment is correct, safety the castellated nut with cotter pin.
- g. If a new link on the top left main gear had to be installed or it had to be reversed during the alignment check, it will be necessary to check the gear safety switch (squat switch) bracket for engagement and locking in place. If the large machine surface of the link is inboard, the bracket is mounted with the small rivet hole next to link. (Refer to Sketch A, Figure 7-7.) This hole should be aligned with centerline of the link and a .096 inch hole drilled .150 inch deep. Insert an MS20426AD3-3 rivet in the hole. This locking rivet is held in place by the flat washer, castellated nut and cotter pin. If link has to be reversed, then the bracket and bolt are also reversed. (Refer to Sketch B, Figure 7-7.)
- h. Check adjustment of landing gear safety switch (squat switch) per Paragraph 7-35.

TABLE VII-III. TOE-IN — TOE-OUT CORRECTION CHART

TOE-IN TOE-OUT ANGLE	SHIM WASHERS	WASHERS UNDER HEAD	WASHERS UNDER NUT	AN 174 BOLT
0°		AN960-416	AN960-416 (3)	-14
0° 33"	AN960-416	AN960-416	AN960-416 (2)	-14
0° 48"	AN960-416L AN960-416	AN960-416	AN960-416	-14
1° 04"	AN960-416 (2)	AN960-416	AN960-416	-14
1° 19"	AN960-416L AN960-416 (2)	AN960-416L	AN960-416	-14
1° 35"	AN960-416 (3)	AN960-416	AN960-416 (2)	-15
2° 35"	AN960-416 (4)	AN960-416	AN960-416	-15
Max. Allow.				
AN960-416L Washers .031 Thick		AN960-416 Washers .062 Thick		

7-26. REMOVAL OF MAIN GEAR DOOR ASSEMBLY.

- a. With the landing gear extended, disconnect the door retraction rod from the door by removing nut, washers and bolt.
- b. Remove the door from the wing panel by bending the door hinge pin straight and from the other end pulling out the pin.
- c. The door retraction rod may be removed from the gear housing by cutting the safety wire and removing the attachment bolt and washer. Note the number of washers between rod end bearing and housing.

7-27. CLEANING, INSPECTION AND REPAIR OF MAIN GEAR DOOR ASSEMBLY.

- a. Clean the door and retraction rod with a suitable cleaning solvent.
- b. Inspect the door for cracks or damage, loose or damaged hinges and brackets.
- c. Inspect the door retraction rod and end bearing for damage and corrosion.
- d. Repairs to a door may be replacement of hinge, repair of fiberglass and painting.

7-28. INSTALLATION OF MAIN GEAR DOOR ASSEMBLY.

- a. Install the door by positioning the hinge halves of the door and wing, and inserting the hinge pin. It is recommended a new pin be used. Bend the end of the pin to secure in place.
- b. Install the door retraction rod by positioning the rod at its attachment points at the door and strut housing. At the door attachment, thin washers are inserted at each side of the rod end bearing and it is secured with bolt, washer and nut. At the strut housing, place washers between rod end bearing and housing not to exceed .12 of an inch to obtain proper clearance and secure with bolt. Safety bolt with MS20995C41 wire.
- c. Check that the all around clearance between the door and the wing skin is not less than .032 of an inch.

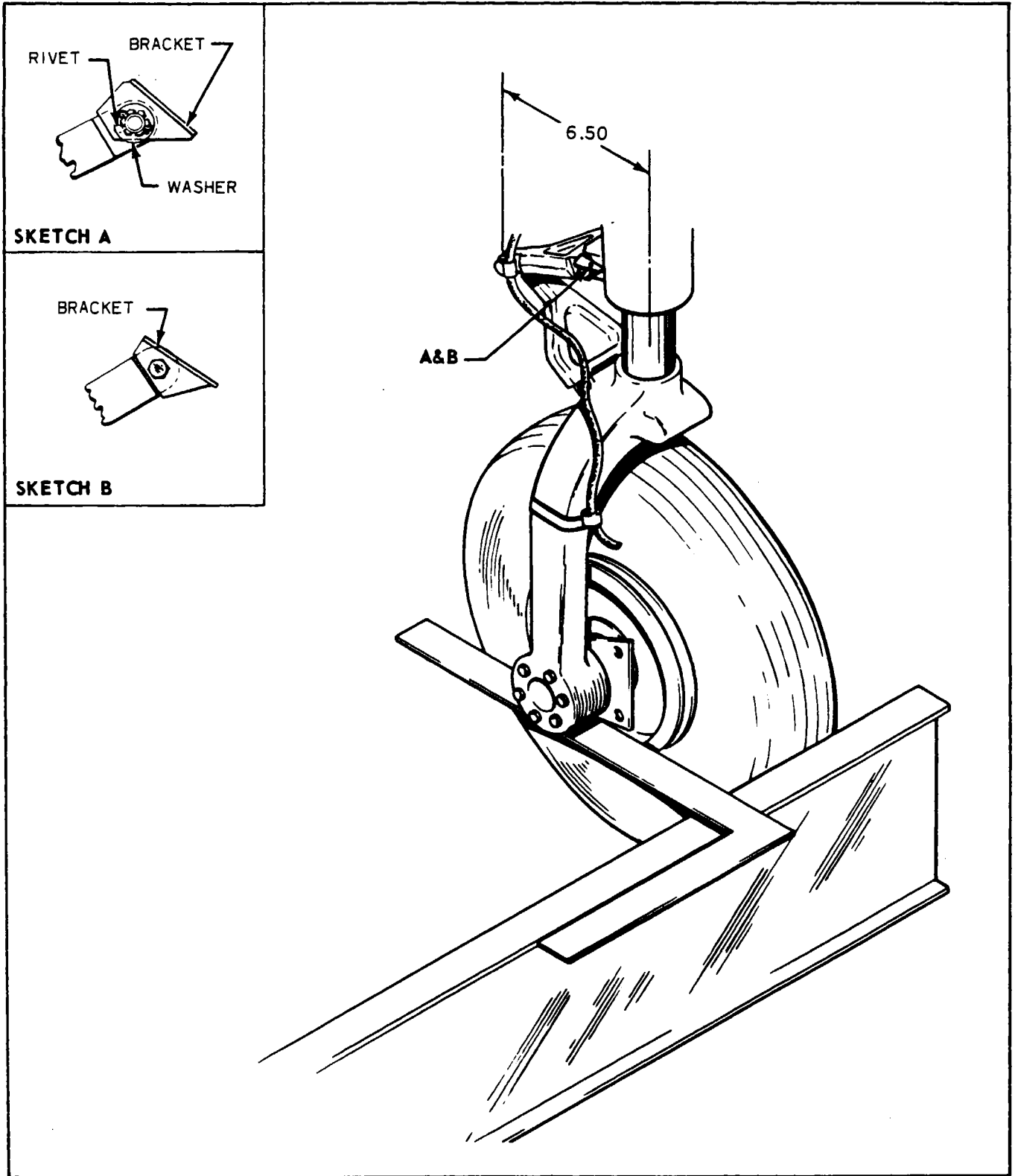

Figure 7-7. Aligning Main Gear

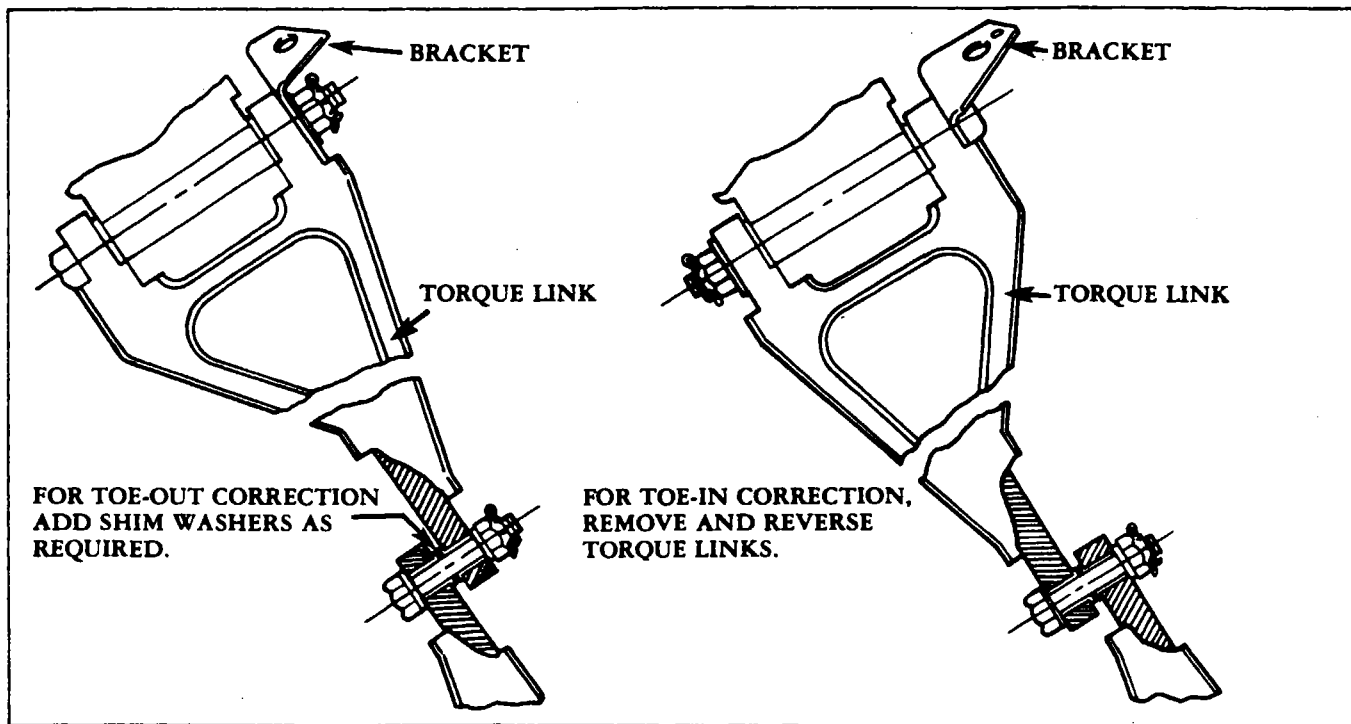

Figure 7-8. Toe-In/Toe-Out Adjustment

THIS SPACE INTENTIONALLY LEFT BLANK

7-29. ADJUSTMENT OF MAIN GEAR DOOR ASSEMBLY.

- a. Place the airplane on jacks.
- b. Determine that the main gear is properly adjusted for gear up as explained in Paragraph 7-24.
- c. Adjust retraction rod end at door so that door will pull up tightly when the gear is full up. Over-tightening may result in door buckling; however, if the door is too loose, it will gap in flight.
- d. Check all rod ends for adequate thread engagement, for safety and tightness of jam nuts.
- e. Remove airplane from jacks.

7-30. LANDING GEAR LIMIT SWITCHES.

NOTE

All adjustments of the limit switches should be made with the airplane on jacks. Do not bend actuator springs mounted on the limit switches.

7-31. ADJUSTMENT OF NOSE GEAR UP LIMIT SWITCH. The gear up limit switch is mounted on a bracket attached to the lower inner left tubular member of the nose gear mount, adjacent to the gear roller track assembly or mounted on the stop assembly. (Refer to Figure 7-2.)

- a. To facilitate adjustment of the limit switch, disconnect gear doors.
- b. Turn the master switch on; move gear selector switch to the gear up position and raise the landing gear. Turn the master switch OFF.
- c. Block the nose gear in the up position and slowly pull the free-fall knob away from the instrument panel. This will relieve hydraulic pressure and permit the main gear to drop.
- d. Loosen the attachment screws of the switch and rotate the switch toward the actuator tang until the switch is heard to actuate. Move the up limit switch upwards .02 to .04 inches after actuation. Retighten the switch attachment screws. Remove the block from under the gear and allow it to extend slowly.
- e. Turn master switch on; raise gear and determine that gear lights function properly.

7-32. ADJUSTMENT OF NOSE GEAR DOWN LIMIT SWITCH. (Refer to Figure 7-9.) The nose gear down limit switch is mounted on a bracket located on the forward side of the cabin bulkhead.

- a. With landing gear in the retracted position, pull the free-fall valve knob permitting the gear to extend.
- b. Check to determine that the downlock spring (1) returns the body end of the actuating cylinder (2) aft.
- c. Ascertain that the downlock link assembly (3) is fully retracted and that the drag link arms (4) are over center.
- d. In this position, the nose gear green downlock light should energize when the master switch is turned on and the gear selector lever is in the down position.
- e. If the nose gear green downlock light does not energize, loosen the attachment screws of the switch and rotate the switch toward the actuator tang until it is heard to actuate. Tighten the adjustment screws.

7-33. ADJUSTMENT OF MAIN GEAR UP LIMIT SWITCH. A gear up limit switch is located in each wheel well above the gear door hinge. The red "GEAR UNSAFE" light is extinguished when all three gears have actuated their up limit switches and the gear selector is in the up position.

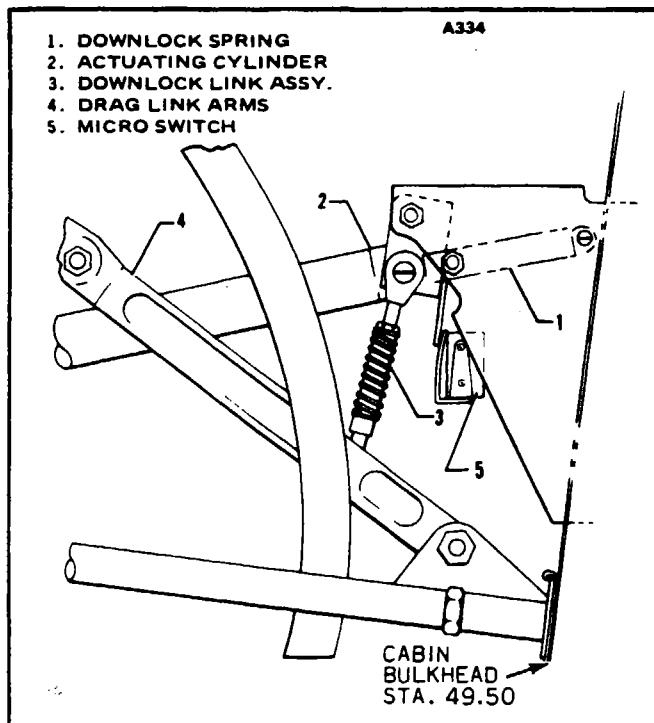

Figure 7-9. Adjust Nose Gear Down Limit Switch

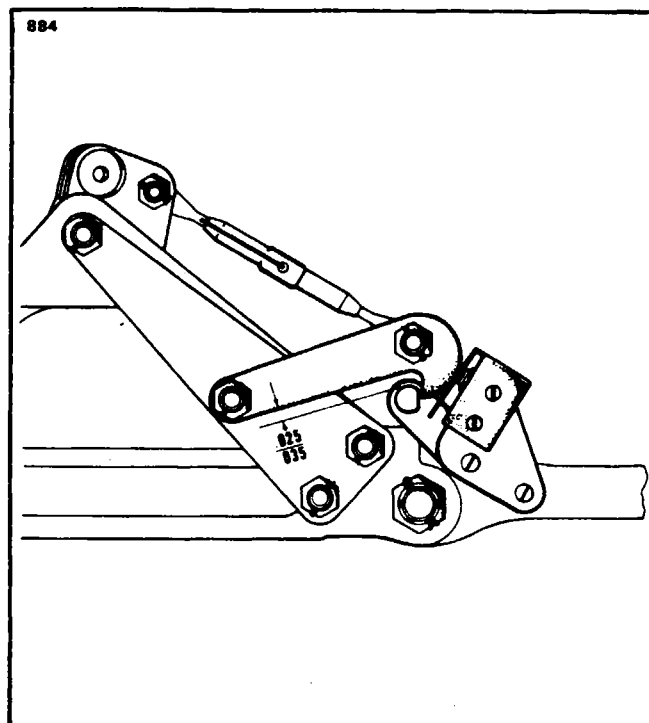

Figure 7-10. Adjust Main Gear Down Limit Switch

7-34. ADJUSTMENT OF MAIN GEAR DOWN LIMIT SWITCH. The gear down limit switch is mounted on a bracket attached to the lower drag link of each main gear. The switch should be adjusted to allow it to actuate when the downlock hook has entered the locked position and is within .025 to .035 inch of contacting the pin thus turning the green light on in the cockpit. (Refer to Figure 7-10.) Adjustment, if necessary, should be made as follows:

- a. Determine that the main gear downlock is properly adjusted as described in Paragraph 7-24.
- b. Raise the airplane on jacks.
- c. Determine that the landing gear is down and pressure is relieved from the hydraulic system. To relieve pressure, pull the free-fall knob out.
- d. Raise the downlock hook assembly and place a .030 inch feeler gauge between the horizontal surface of the hook that is next to the switch (the surface that contacts the downlock pin) and the rounded surface of the pin. Lower the hook and allow it to rest on the feeler gauge.
- e. Loosen the attaching screws of the switch and, while pushing up on center of the link assembly, rotate the switch toward the hook until it is heard to actuate. Retighten the attaching screws of the switch.
- f. Manually move the hook assembly up from the pin until the hook nearly disengages from the pin. Then with pressure against the bottom of the link assembly, move back to determine that the switch actuates within .025 to .035 inch of full lock.
- g. Turn the master switch on and raise and lower the landing gear by means of the gear selector switch to determine the gear downlock and gear unsafe annunciator lights function properly.

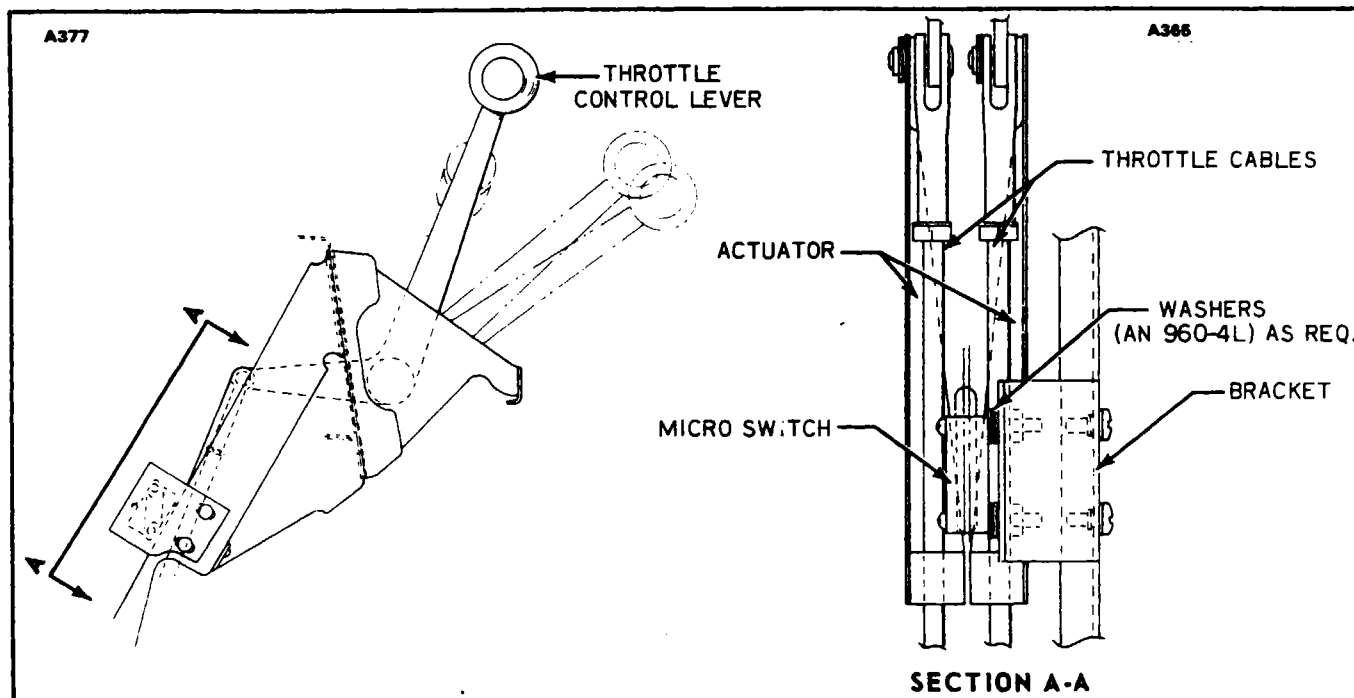

Figure 7-11. Throttle Warning Switch

7-35. ADJUSTMENT OF LANDING GEAR SAFETY SWITCH (SQUAT SWITCH) AND GROUND STALL WARNING PREVENTION SWITCH. The landing gear safety switch and the ground stall warning prevention switch located on the left main gear housing are adjusted so that the switches are actuated within the last quarter inch of gear extension.

a. Compress strut until a distance of 7.875 inches is obtained between the top of the gear fork and the bottom of the gear housing. Hold the gear at this measurement.

b. Adjust the squat switch and the ground stall warning prevention switch to actuate at this point. Secure the switch.

c. Extend and then compress the strut to ascertain the switches will actuate within the last quarter inch of oleo extension.

7-36. LANDING GEAR WARNING SWITCH (THROTTLE SWITCH).

7-37. LANDING GEAR UP/POWER REDUCED WARNING SWITCH. This switch will automatically activate a warning horn when approaching for a landing with the landing gear up and the throttles pulled below 14 inches of manifold pressure.

7-38. SWITCH LOCATION. The landing gear up/power reduced warning switch is located in the control quadrant behind the throttle levers. Access to the switch is from below and behind the quadrant. Refer to Section XI for electrical schematic of the Landing Gear System.

7-39. ADJUSTMENT OF LANDING GEAR UP/POWER REDUCED WARNING SWITCH. The adjustment of this switch will require flying the airplane at 1000 feet AGL and at approach speed. (Refer to the Pilot's Operating Manual.) The following procedure should be used:

a. With the aid of a qualified pilot, fly the airplane to an elevation of 1000 feet above the ground and come to approach speed with propellers set for high RPM. Retard the throttles to 14 ± 2 inches of manifold pressure and mark the quadrant cover adjacent to the throttle levers, in such a manner so that the levers can be returned to the same position after the airplane is landed and the engines shut down.

b. Place the airplane on jacks (refer to Section II of this manual) and retract the landing gear.

- c. Reposition the throttle levers at the location which gave the 14 ± 2 inches of manifold pressure per Step a.
- d. With the master switch turned on, loosen the two mounting screws securing the micro switch to the bracket. Move the switch in the direction necessary to make the warning horn operate and tighten the mounting screws.
- e. With the warning horn operating, lower the landing gear to determine whether the horn ceases to operate when the gear are down and locked. Turn OFF master switch and remove airplane from jacks.
- f. Flight test the airplane to insure proper operation of the gear warning horn with the gear up and power reduced below 14 ± 2 inches of manifold pressure.

7-40. REPLACEMENT OF LANDING GEAR UP/POWER REDUCED WARNING SWITCH. (Refer to Figure 7-11.) When replacing the switch, it is important to determine how many washers are positioned between the micro switch and the bracket so that an equal amount are reinstalled. This is necessary since the switch when properly positioned should be in the middle of the actuators located on each throttle cable.

7-40a. FUNCTIONAL TEST OF LANDING GEAR RETRACTION SYSTEM.

PPS40033E

NOTE

During testing, keep hydraulic fluid level in reservoir at $\frac{1}{2}$ inch below top of filler hole.

- a. Jack airplane.
- b. Apply 12-14 volt auxiliary power.
- c. Turn all switches off, place gear selector in the down position and place throttles in closed position.
- d. Turn master switch on.
- e. Insure that:
 - 1. Three green safe lights are on.
 - 2. Red gear unsafe light is off.
 - 3. The gear warning horn does not sound.
 - 4. Hydraulic pump does not operate.
- f. Place gear selector switch up.
- g. Insure that:
 - 1. Three green safe lights are off.
 - 2. Red gear unsafe light is on.
 - 3. Gear warning horn sounds.
 - 4. All gear retract fully and nose gear doors close.
 - 5. Pump motor stops operating.
- h. Move the left throttle to mid-travel position. Warning horn should continue to sound and red gear unsafe light should remain on.
- i. Close left throttle, then move right throttle mid-travel position. The warning horn should continue to sound and the red unsafe light should remain on.
- j. Move both throttles to mid-travel position. The warning horn should stop sounding and the red unsafe light should go out.
- k. Leave the gear up for five minutes.
 - 1. Check that the pump motor does not operate at any time. (If pump motor operates during this time, there is a leak in the up line or a component is malfunctioning.) See following step.
 - 2. One momentary pump operation is allowable during this five minute period only if the gear unsafe light is not lit and there is no repeated pump operation for a subsequent 15 minute period.

PIPER SENECA II SERVICE MANUAL

- l. Turn master switch off.
- m. Pull gear free-fall knob. All gear should return to the down and locked position with the down latches engaged.
- n. Place gear selector switch down, free-fall knob in and turn master switch on.
- o. Insure that:
 - 1. Three green safe lights are on.
 - 2. The red unsafe light is off.
 - 3. The warning horn does not sound.
- p. Insert a wedge under the leaf of the squat switch on the left main gear.
- q. Place throttles in closed position and gear selector switch up.
- r. Insure that:
 - 1. Pump does not run.
 - 2. Three green safe lights remain on.
 - 3. Red unsafe light remains on.
 - 4. Gear warning horn sounds.
- s. Move throttles to mid travel position.
- t. Insure that:
 - 1. Red unsafe light stays on.
 - 2. Gear warning horn continues to sound (S/N's to 34-8170115).
or
Gear warning horn does not sound (S/N 34-8133001 and up).
- u. Place gear selector switch down.
- v. Insure that:
 - 1. Red gear unsafe light goes off.
 - 2. Gear warning horn does not sound.
- w. Remove wedge installed in step "P".
- x. Manually break left main gear down lock.
- y. Insure that:
 - 1. Pump motor operates.
 - 2. Appropriate green safe light goes out.
 - 3. Red gear unsafe light goes on.
 - 4. Horn does not sound.
- z. Repeat step "y" at the right gear down lock.
- aa. Place gear selector switch up and landing light switches on.
- ab. Insure that:
 - 1. Pump motor operates.
 - 2. Three green safe lights go out.
 - 3. The red unsafe light remains on until all gears are up; then off.
 - 4. All gears retract fully in less than 10 seconds.
 - 5. Pump motor stops operating after gear is up.
 - 6. Warning horn does not sound.
 - 7. Landing light goes off when gear is fully retracted.
- ac. Place gear selector switch down.
- ad. Insure that:
 - 1. Pump motor operates.
 - 2. All gear return to the down and locked position.
 - 3. Pump motor stops operating after all gear are in the down and locked position.
 - 4. The three green safe lights are on.
 - 5. The red unsafe light is off.

6. The warning horn does not sound.

NOTE

Any momentary blinking of the red / green gear lights after the down locks are engaged indicates an improperly adjusted microswitch.

- ae. Turn navigation light switch on. Insure that three green safe lights remain on but become dim.
af. Turn navigation light and master switches off.

7-41. WHEELS.

7-42. REMOVAL AND DISASSEMBLY OF NOSE WHEEL. (Refer to Figure 7-12.)

- a. Jack the airplane enough to raise the nose wheel clear of the ground.
b. To remove the nose wheel, first remove the nut from one end of the axle rod and slide out the rod and axle plugs.
c. Lightly tap the axle tube out from the center of the wheel assembly by use of an object of near equal diameter.

NOTE

Exercise care to avoid damaging axle tube ends. This will make removal and installation extremely difficult.

- d. Remove spacer tubes and wheel assembly.
e. Deflate the tire. Remove wheel bolts (4). Pull wheel halves from the tire by removing the wheel half opposite the valve stem first and then the other half.
f. Remove screws (6), grease seal (8), seal retainers (7) and bearing cones (9). Remove bearing cup (10) by tapping evenly from the inside.

7-43. INSPECTION OF NOSE WHEEL ASSEMBLY.

- a. Visually check all parts for cracks, distortion, defects and excess wear.
b. Check wheel bolts for stripped or damaged threads.
c. Check internal diameter of felt grease seals. Replace the felt grease seal if surface is hard or gritty.
d. Check tire for cuts, internal bruises and deterioration.
e. Check bearing cones and cups for wear and pitting then relubricate.
f. Replace any wheel casting having visible cracks.

7-44. ASSEMBLY AND INSTALLATION OF NOSE WHEEL. (Refer to Figure 7-12.)

- a. Carefully install bearing cups (10) into each wheel half (1 and 2).
b. Install the inner tube in the tire, making certain to align the index marking on the tire with the index marking on the tube, to insure proper wheel balance.
c. Install the tire and tube on the wheel half with the valve stem hole, inserting the valve stem through the valve hole.

1K24
INTENTIONALLY LEFT BLANK

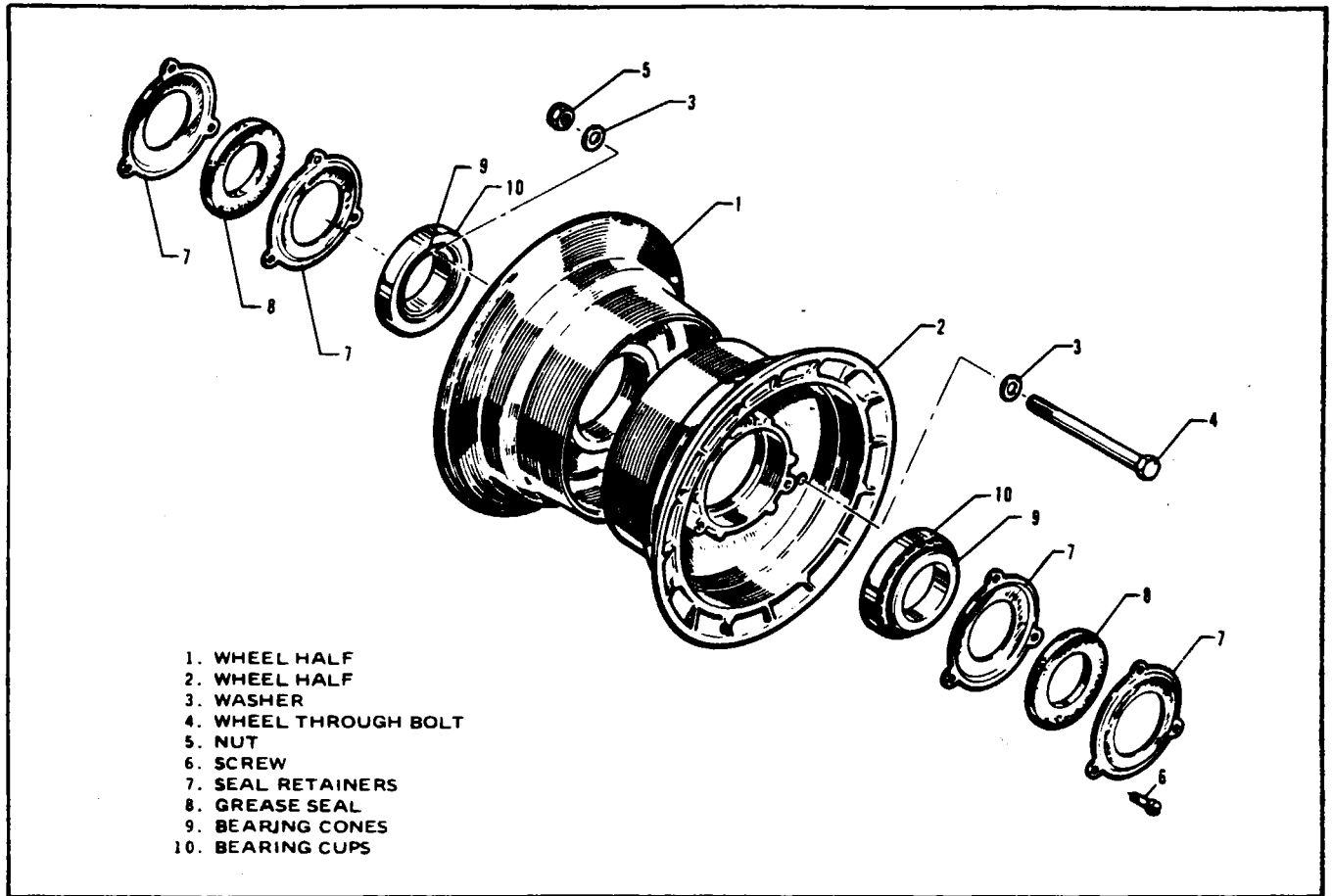

Figure 7-12. Nose Wheel Assembly

d. Place the opposite wheel half inside the tire. Align the wheel bolt holes, install the wheel bolts (4), with washers (3) and nuts (5) to the valve stem side and tighten (draw up) the bolts in a criss-cross fashion. Torque the nuts to 90 inch-pounds and inflate the tire to 46 psi to seat the tire bead, then deflate the tire to proper inflation. (Refer to Section II, Table II-1.)

e. Lubricate bearing cones (9) and install cones, inner seal retainers (7) and grease seals (8). Secure outer seal retainer with three screws (6).

f. Place one spacer tube in each side of wheel and position wheel in fork. Align and slide axle tube through spacer tubes and wheel assembly. Install axle plugs and tie rod and secure with nuts. Tighten the nuts until no side play is felt, yet allowing the wheel to rotate freely.

7-45. REMOVAL AND DISASSEMBLY OF MAIN WHEEL. (Refer to Figure 7-13.)

- a. Place airplane on jacks.
- b. To remove main wheel, remove cap bolts joining brake cylinder housing and back plate lining assemblies. Remove back plate from between brake disc and wheel.
- c. Remove the dust cover and cotter pin that safeties axle nut; remove axle nut and bushing and slide wheel from the axle.
- d. The wheel halves (1 and 2) may be separated by first deflating the tire. With tire deflated, remove bolts (9). Pull wheel halves from tire by first removing inner half from the tire then the outer half.
- e. Wheel bearing assemblies may be removed from each wheel half by removing snap rings (13), grease seal rings (12 and 15), felt grease seals (14) and bearing cone (11). Bearing cups (10) should not be removed unless in need of replacement. To remove bearing cups, refer to paragraph 7-46.

Reissued: 10/11/79

LANDING GEAR AND BRAKE SYSTEM

7-46. BEARING CUP REPLACEMENT

a. Removal:

1. Insert wheel half into boiling water for 15 minutes or place in an oven not exceeding 250° F (121° C) for 15 minutes.

2. Remove from source of heat and invert wheel half. If the cup does not drop out, tap the cup evenly from the axle bore with a fiber drift pin or suitable arbor press.

b. Installation:

1. To replace a new cup, apply one coat of zinc chromate primer to wheel half bearing bore.

NOTE

Never paint working surfaces of the bearing cups.

2. Insert wheel half into boiling water for 15 minutes or place in an oven not exceeding 250° F (121° C) for 15 minutes. Chill new bearing cup in dry ice for a minimum of 15 minutes.

3. Remove wheel half from source of heat and bearing cup from the dry ice. Install the chilled bearing cup into the bearing bore of the heated wheel half. Tap gently to seat evenly in place, using a fiber drift pin or suitable arbor press.

7-47. INSPECTION OF MAIN WHEEL ASSEMBLY. Inspection of the main wheel assembly is the same as that given for the nose wheel, Paragraph 7-43.

7-48. ASSEMBLY AND INSTALLATION OF MAIN WHEEL. (Refer to Figure 7-13.)

a. Determine that the bearing cup (10) is properly installed in each wheel half.

b. Install the inner tube in the tire, making certain to align the index marking on the tire with the index marking on the tube, to insure proper wheel balance.

c. Install the tire and tube on the wheel half with the valve stem hole, inserting the valve stem through the valve hole.

d. Place the opposite wheel half inside the tire. Align the wheel bolt holes. Position the brake disc (3) in the inner wheel half and install the wheel bolts (9) with nuts on the valve stem side. Tighten (draw up) the bolts in a criss-cross fashion. Torque the nuts to 150 inch-pounds and inflate the tire to 70 psi to seat the tire bead, then deflate the tire to proper inflation. (Refer to Section II, Table II-I.)

e. Lubricate bearing cones (11) and install cones, felt grease seals (14) and grease seal rings (12 and 15). Secure with snap rings (13).

f. Slide wheel on the axle and secure with axle nut. Tighten nut sufficiently to prevent side play, yet allow the wheel to rotate freely. Reinstall the dust cover (6).

g. Position brake lining back plates between the wheel and brake disc and the brake cylinder on the torque plate. Insert spacer blocks between the back plates and cylinder, and install four bolts to secure the assembly. If the brake line was disconnected, reconnect the line and bleed the brakes.

7-49. BRAKE SYSTEM.

7-50. WHEEL BRAKE ASSEMBLY. Adjustment of brake lining clearance is unnecessary since they are self-adjusting. Inspection of the lining is necessary and may be inspected visually while installed on the airplane. The linings are of the riveted type and should be replaced if the thickness of any one segment becomes worn below .099 of an inch or if signs of uneven wear are evident.

7-51. REMOVAL AND DISASSEMBLY OF WHEEL BRAKE ASSEMBLY. (Refer to Figure 7-14.)

a. To remove brake assembly, first disconnect brake line from brake cylinder at the elbow (18).

b. Remove bolts (14) joining brake cylinder housing (1) and back plate assembly (7). Remove back plate from between brake disc and wheel.

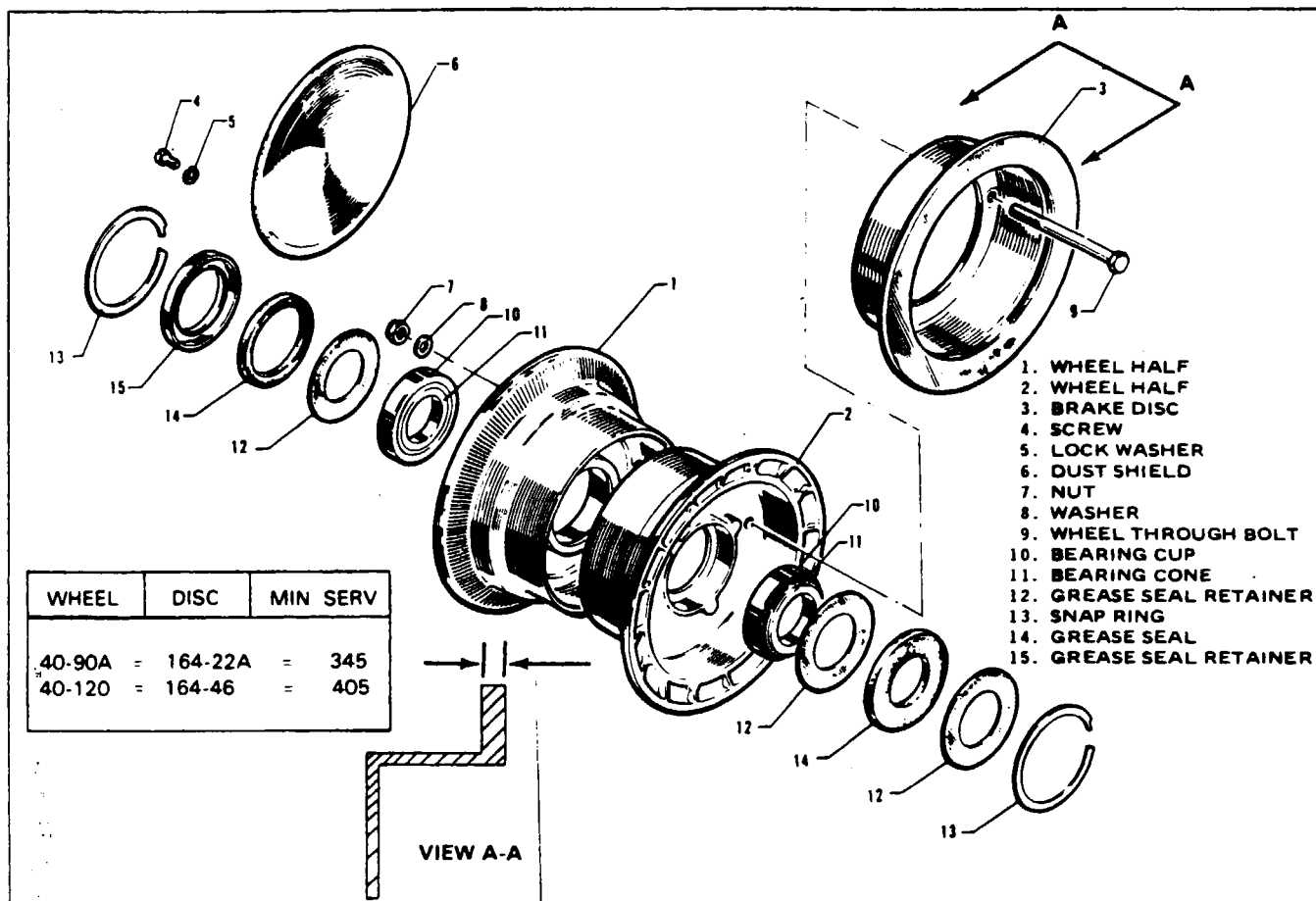

Figure 7-13. Main Wheel Assembly

- c. Slide brake cylinder housing from torque plate (10).
- d. Remove pressure plate (4) by sliding it off the anchor bolts (11) of brake cylinder housing.
- e. The pistons (2) may be removed by injecting low air pressure in the cylinder fluid inlet, forcing the pistons from the housing.
- f. Check anchor bolts for wear.
- g. The following procedure should be used when removing anchor bolts:
 1. Position cylinder assembly on a holding fixture. (Refer to Figure 7-15, Step A.)
 2. Use a suitable arbor press and remove the anchor bolt from the cylinder body.

7-52. CLEANING, INSPECTION AND REPAIR OF WHEEL BRAKE ASSEMBLY.

- a. Clean the assembly with a suitable solvent and dry thoroughly.
- b. Check the wall of the cylinder housing and piston for scratches, burrs, corrosion, etc., that may damage "O" rings.
- c. Check the general condition of the brake bleeder screw and lines.

NOTE

Heavy duty wheel assemblies and brake discs may be easily identified by six (6) bolt hole pattern. Standard wheel assemblies and disc brakes have a three (3) bolt hole pattern.

PIPER SENECA II SERVICE MANUAL

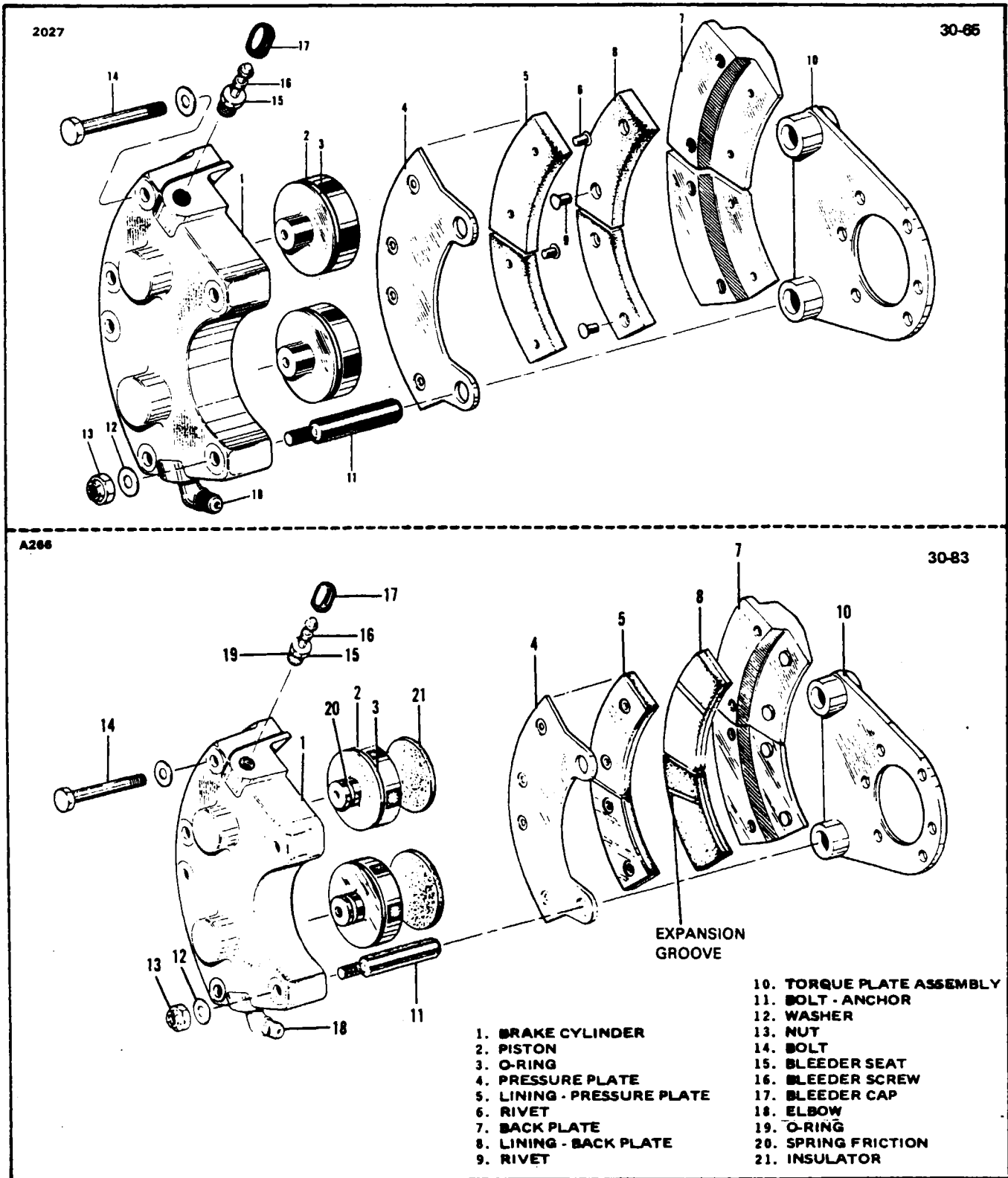

Figure 7-14. Wheel Brake Assembly

A122

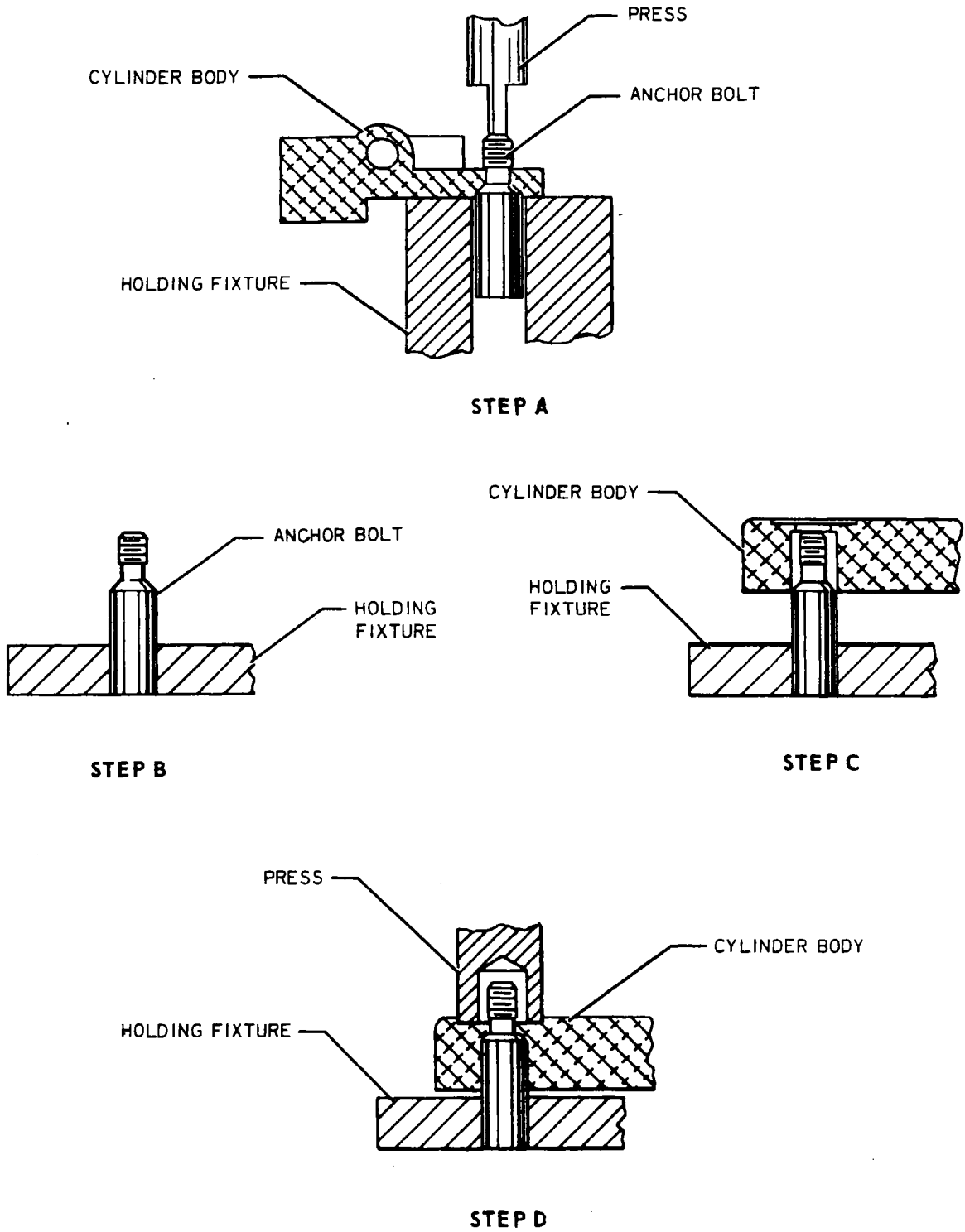

Figure 7-15. Removal and Installation of Anchor Bolts

Reissued: 10/11/79

LANDING GEAR AND BRAKE SYSTEM

PIPER SENECA II SERVICE MANUAL

d. Check the brake disc for wear, grooves, scratches or pits. Minimum service thickness of Disc 164-22A used on Wheel Assembly 40-90A is .345. A heavy duty brake and wheel assembly is optional. The minimum disc thickness of Disc 164-46 used on heavy duty Wheel Assembly 40-120 is .405. A single groove or isolated grooves up to .031 of an inch deep would not necessitate replacement, but a grooving of the entire surface would reduce lining life and should be replaced. Should it be necessary to remove the wheel disc, refer to Paragraph 7-44. To inspect the press-on type heavy-duty brake lining, check the expansion groove. If groove is not showing, replace linings.

e. At each periodic maintenance inspection, visually inspect both wearing surfaces of the brake disc for heat checks. Replace brake disc if crack length exceeds .800, or crack depth exceeds .210. If crack depth is not measurable, replace disc if crack length exceeds .400.

NOTE

Any crack, regardless of length and or depth, extending into the welded seam between the flange and cup, is cause for immediate replacement.

f. The riveted type lining may be removed from the backing plates by drilling out the old rivets using a 5/32 drill. Install a new set of linings using the proper rivets and a rivet set that will properly stake the lining and form a correct flair of the rivet. The snap-on type lining used on optional heavy duty assemblies may be removed by prying loose with a screwdriver or a thin flat wedge. Install the snap-on type by positioning onto the pins and applying pressure to snap into position.

NOTE

After replacing brake linings on Cleveland 30-65 brakes, perform a minimum of six light braking applications with time left between stops to allow them to cool.

After replacing the brake linings on Cleveland 30-83 brakes, execute three consecutive hard brakings from 45 to 50 mph without allowing the brake discs to cool substantially between stops.

7-53. ASSEMBLY AND INSTALLATION OF WHEEL BRAKE ASSEMBLY. (Refer to Figure 7-14.)

- a. If anchor bolts have been removed, they should be reinstalled as follows:
 1. Support anchor bolt in a holding fixture. (Refer to Figure 7-15, Step B.)
 2. Align cylinder body over anchor bolt. (Refer to Figure 7-15, Step C.)
 3. Using a suitable arbor press, apply pressure on the spot face directly over the anchor bolt. (Refer to Figure 7-15, Step D.)
- b. Lubricate piston O-rings (3) with hydraulic fluid (MIL-H-5606) and install on pistons (2). Slide piston into cylinder housing (1) until flush with surface of housing.
- c. Slide pressure plate (4) onto anchor bolts (11) of housing.
- d. Slide cylinder housing on torque plate (10).
- e. Position back plate (7) between wheel and brake disc. Install bolts and torque to 40 inch-pounds to secure the assembly.
- f. Connect brake line to cylinder housing and bleed brake system as described in Paragraph 7-66 or 7-67.

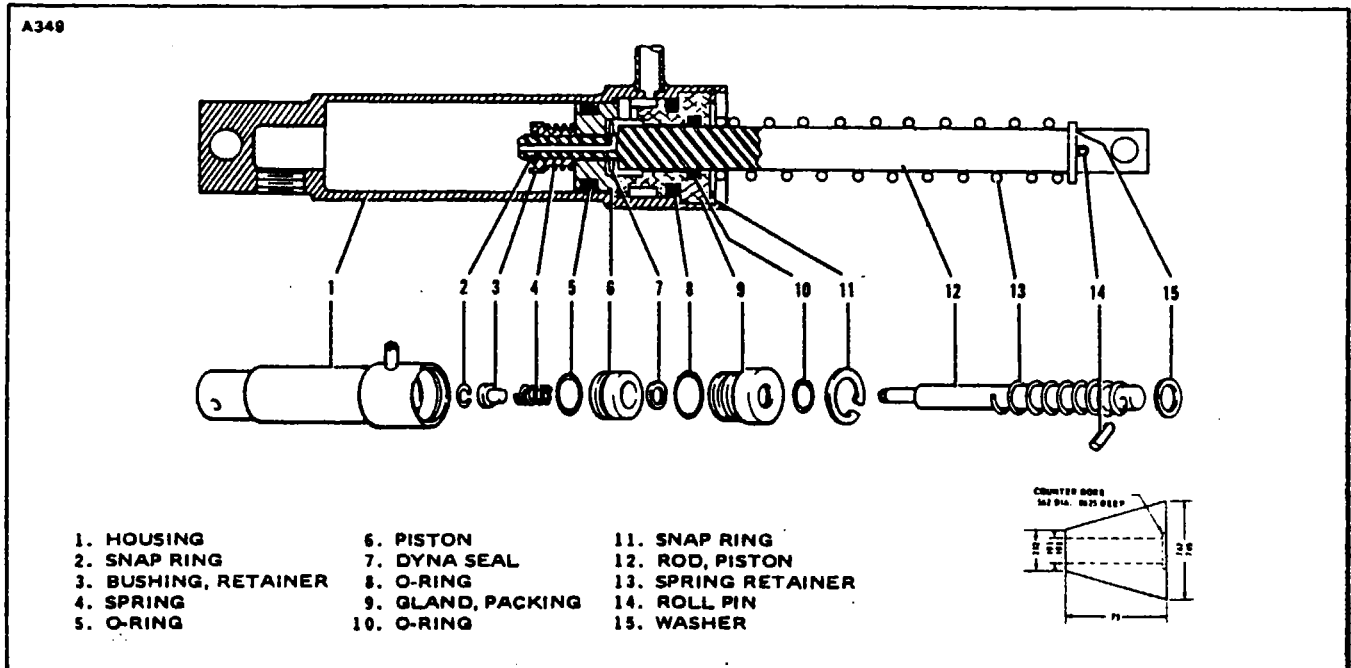

Figure 7-16. Brake Master Cylinder (Hand, Parking Brake)

7-54. BRAKE MASTER CYLINDER (HAND PARKING BRAKE).

7-55. REMOVAL OF BRAKE MASTER CYLINDER. (Refer to Figure 7-17.)

- a. To remove brake master cylinder (8), first disconnect inlet supply line (13) from fitting at top of cylinder and allow fluid to drain from the reservoir and line into a suitable clean container.
- b. Disconnect pressure line from fitting at bottom of cylinder and allow fluid to drain from the pressure line.
- c. Disconnect end of cylinder rod from the brake handle (6) by removing the cotter pin that safeties the connecting clevis pin (12). Remove clevis pin and spacer washers.
- d. Disconnect the base of the cylinder from its mounting bracket by removing bolt assembly (11).
- e. The handle assembly (6) may be removed by removing attachment bolt assembly securing handle to its mounting bracket.

7-56. DISASSEMBLY OF BRAKE MASTER CYLINDER. (Refer to Figure 7-16.)

- a. Remove snap ring (11) from annular slot in rod end of cylinder and withdraw piston rod assembly.
- b. Disassemble piston rod assembly by removing snap ring (2) securing retainer bushing (3), spring (4), piston (6), seal (7), gland (9) and large retaining spring (13).
- c. Remove O-ring from piston and gland.

7-57. CLEANING, INSPECTION AND REPAIR OF BRAKE MASTER CYLINDER.

- a. Clean cylinder components using a suitable solvent; then dry thoroughly.
- b. Inspect interior walls of cylinder for scratches, nicks, burrs, corrosion, etc.
- c. Inspect general condition of fitting threads.
- d. Check piston and valve for scratches, burrs and corrosion.
- e. Repairs to the cylinder are limited to polishing out small scratches and burrs and replacing washer seal and O-rings.

PIPER SENECA II SERVICE MANUAL

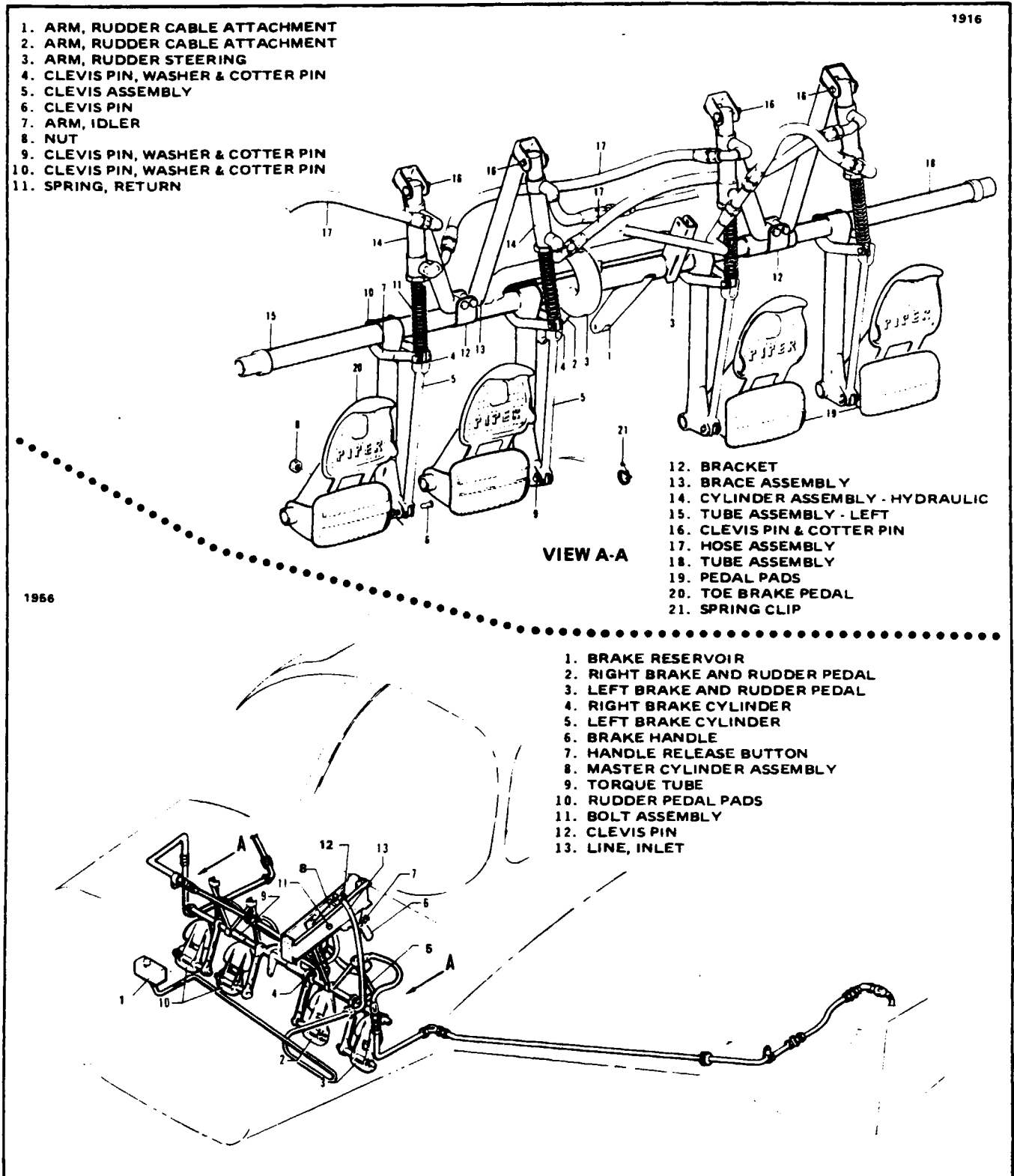

Figure 7-17. Brake System Installation

PIPER SENECA II SERVICE MANUAL

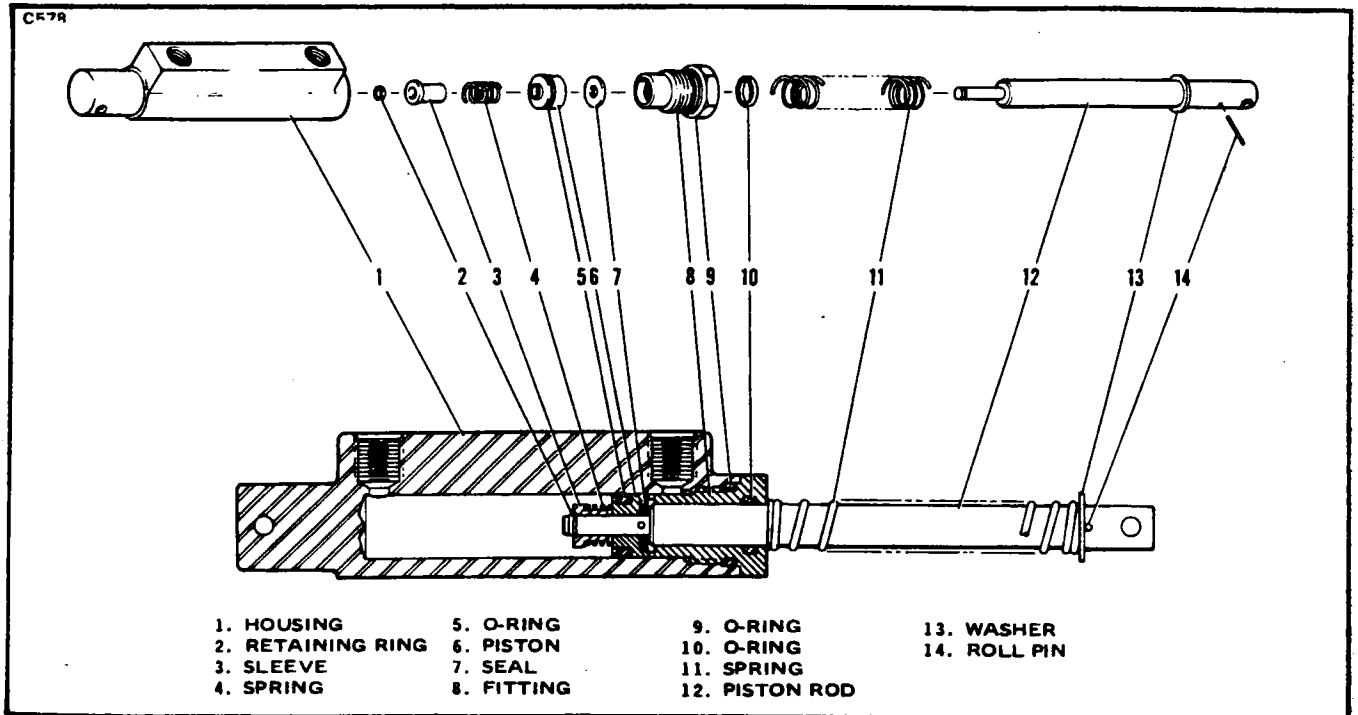

Figure 7-18. Brake Cylinder
(17000) (Toe Brake)

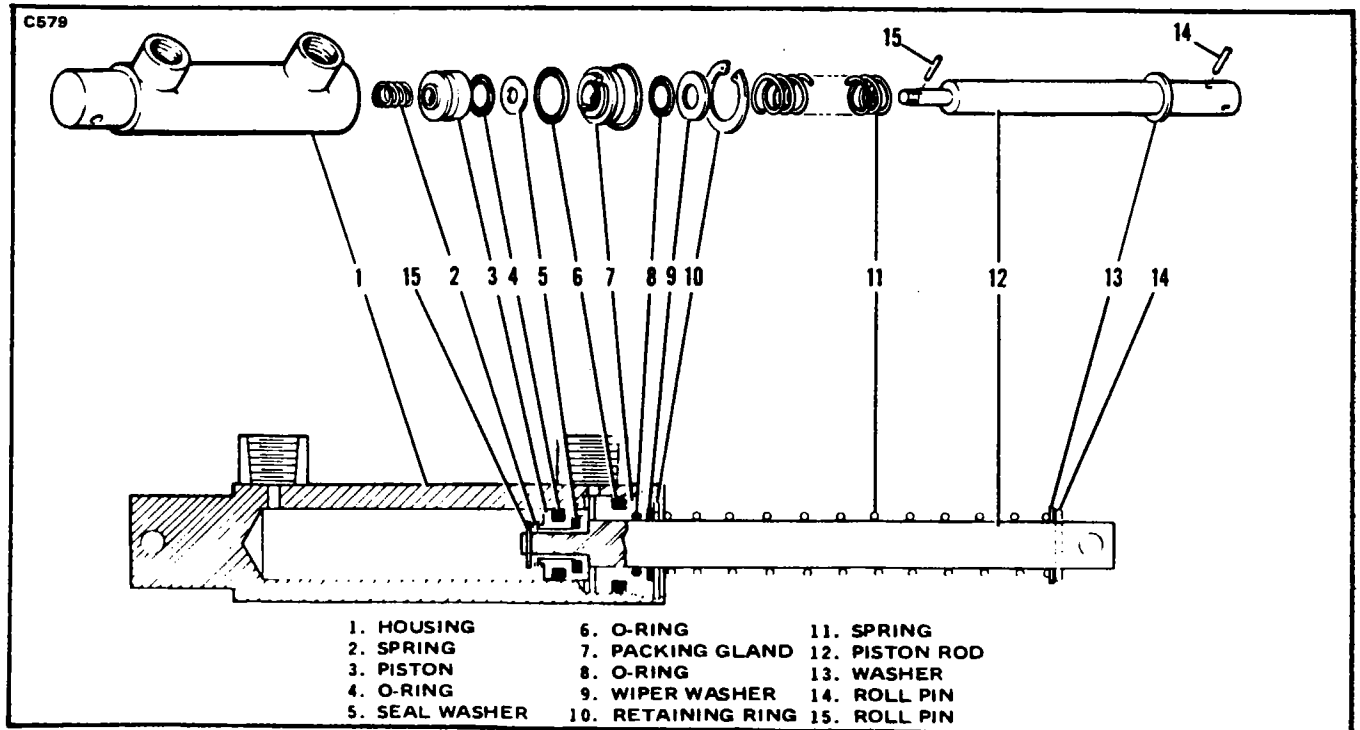

Figure 7-19. Brake Cylinder
(10-27) (Toe Brake)

Reissued: 10/11/79

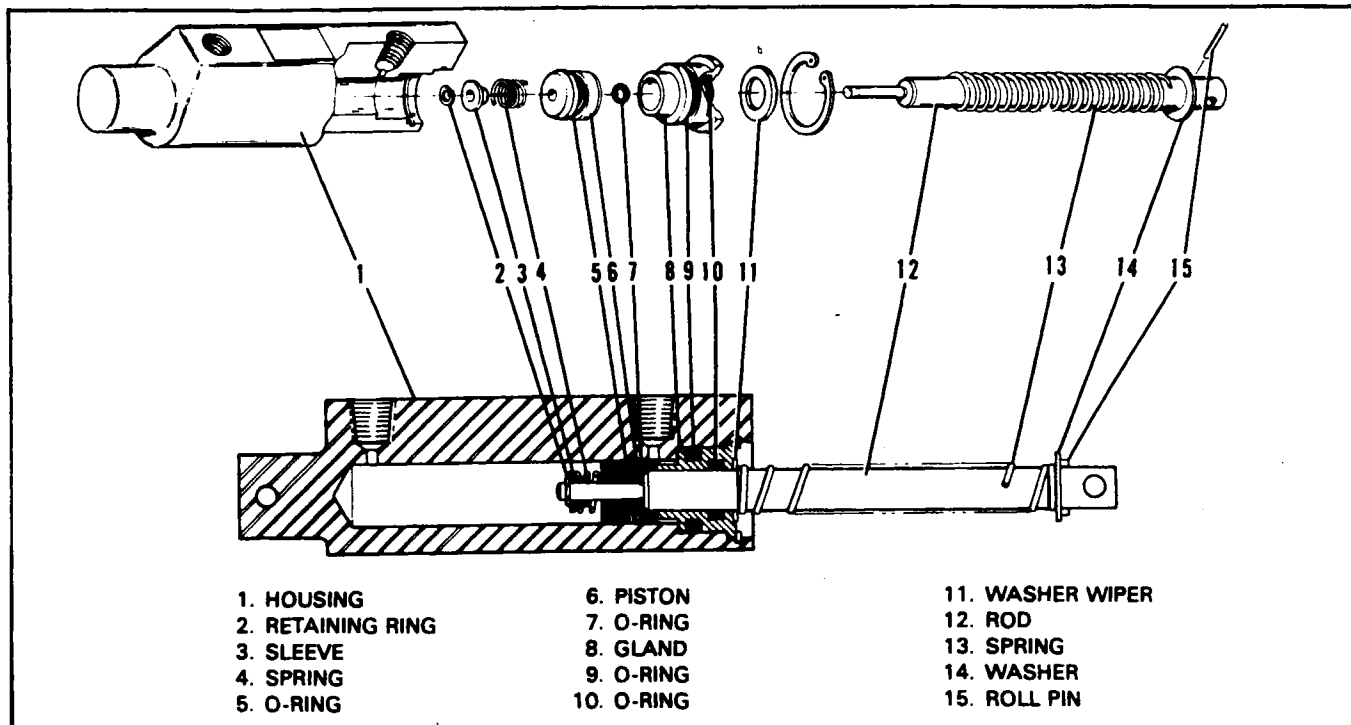

Figure 7-20. Brake Cylinder
(10-30) (Toe Brake)

7-58. ASSEMBLY OF BRAKE MASTER CYLINDER. (Refer to Figure 7-16.)

- a. Apply a small amount of hydraulic fluid (MIL-H-5606) to component parts and O-rings.
- b. Install new O-rings on inside and outside of packing gland (9) and on outside of piston (6).

NOTE

When installing teflon O-ring (5) on piston, it is suggested it be installed with the use of a cone placed against the piston. Dimensions for constructing a cone of plastic or metal are shown in Figure 7-16.

- c. To assemble piston rod assembly, install on rod (12), in order, roll pin (14), washer (15), spring (13), packing gland (9) with O-rings, seal (10), piston (6) with O-rings, spring (4) and bushing (3). Secure these components with snap ring (2).
- d. Insert piston rod assembly into cylinder (1) and secure packing gland with snap ring (11).
- e. Install cylinder as explained in Paragraph 7-59.

7-59. INSTALLATION OF BRAKE MASTER CYLINDER. (Refer to Figure 7-17.)

- a. Install brake handle assembly between its mounting bracket and secure with bolt, washers, nut and cotter pin. Washers should be placed on each side of the handle, between the bracket, and under the nut.
- b. Place cylinder (8) between the mounting bracket and secure base end with bolt, washers, nut and cotter pin. This too should have washers placed on each side of the cylinder and under the nut.
- c. Connect rod end of cylinder to the brake handle with a clevis pin and thin washers. Safety clevis with a cotter pin.
- d. Connect pressure line to fitting at bottom of cylinder.

- e. Connect inlet supply line (13) to fitting at top of cylinder and secure with spring clamp.
- f. Bleed brake system as explained in Paragraph 7-66 or 7-67.

7-60. BRAKE CYLINDER (TOE BRAKE).

7-61. REMOVAL OF BRAKE CYLINDER. (Refer to Figure 7-17.)

- a. Disconnect upper and lower lines from the cylinder (14) being removed. Cap lines to prevent fluid leakage or drain fluid from brake reservoir and master cylinder.
- b. Remove cotter pins and clevis pins (4 and 16) securing brake cylinder in position; then remove brake cylinder.

7-62. DISASSEMBLY OF BRAKE CYLINDER.

- a. Gar-Kenyon cylinder number 17000. (Refer to Figure 7-18.)
 - 1. Remove the cylinder from its mounting bracket as per Paragraph 7-61.
 - 2. To disassemble the cylinder, first remove the piston rod assembly by unscrewing the fitting (8) from the cylinder.
 - 3. The piston rod assembly may be disassembled by first removing the retaining ring (2) securing the sleeve (3) and then removing the spring (4), piston (6), seal (7), fitting (8), and, if desired, the large return spring (11).
 - 4. Remove the O-rings from the piston and fitting.
- b. Cleveland cylinder number 10-27. (Refer to Figure 7-19.)
 - 1. Remove the cylinder from its mounting bracket per Paragraph 7-61.
 - 2. To disassemble the cylinder, first remove the piston rod assembly by removing the retaining ring (10) from the annular slot in the cylinder housing (1). Draw the piston rod assembly from the cylinder.
 - 3. The piston rod assembly may be disassembled by first removing the roll pin (15), spring (2), and then the piston assembly (3), seal (5) and packing gland (7) and, if desired, the large return spring (11).
 - 4. Remove the O-rings from the piston and packing gland.
- c. Cleveland cylinder number 10-30. (Refer to Figure 7-20.)
 - 1. Remove the cylinder from its mounting bracket per Paragraph 7-61.
 - 2. To disassemble the cylinder, first remove the piston rod assembly by removing the retaining ring from the annular slot in the cylinder housing (1). Draw the piston rod assembly from the cylinder.
 - 3. The piston rod assembly may be disassembled by first removing the retaining ring (2), sleeve (3), spring (4), and then the piston assembly, O-ring (5), and gland (8), and if desired, the return spring (13).
 - 4. Remove the O-rings from the piston and packing gland.

7-63. CLEANING, INSPECTION AND REPAIR OF BRAKE CYLINDER.

- a. Clean cylinder components with a suitable solvent and dry thoroughly.
- b. Inspect interior walls of cylinder for scratches, burrs, corrosion, etc.
- c. Inspect general condition of fitting threads.
- d. Inspect piston for scratches, burrs, corrosion, etc.
- e. Repairs to the cylinder are limited to polishing out small scratches and burrs, and replacing seal and O-rings.

7-64. ASSEMBLY OF BRAKE CYLINDER. (Refer to Figures 7-18 and 7-19.)

NOTE

Rub a small amount of hydraulic fluid (MIL-H-5606) on all O-rings and component parts for ease of handling during reassembly and to prevent damage.

PIPER SENECA II SERVICE MANUAL

- a. Gar-Kenyon cylinder number 17000. (Refer to Figure 7-18.)
 1. Install new O-rings on the inside and outside of the fitting (8) and on the outside of the piston (6).
 2. To assemble the piston rod assembly, install on the rod (12), in order, the roll pin (14), return spring retainer washer (13), return spring (11), fitting (8) with O-rings, seal (7), piston (6) with O-rings, spring (4) and sleeve (3). Secure these pieces with the retaining ring (2) on the end of the rod.
 3. Insert the piston rod assembly in the cylinder (1) and secure fitting (8).
 4. Install the cylinder per Paragraph 7-65.
- b. Cleveland cylinder number 10-27. (Refer to Figure 7-19.)
 1. Install new O-rings on the inside and on the outside of the piston (3).
 2. To assemble the piston rod assembly, install on the rod (12), in order, the roll pin (14), washer (13), spring (11), washer (9), packing gland (7) with O-rings, seal (5), piston assembly (3) with O-rings, spring (2), and roll pin (15).
 3. Insert the piston rod assembly in the cylinder (1) and secure with the retaining ring (10).
 4. Install the cylinder per Paragraph 7-65.
- c. Cleveland cylinder number 10-30 (Refer to Figure 7-20.)
 1. Install new O-rings on the inside and outside of the packing gland (7) and on the outside of the piston (3).
 2. To assemble the piston rod assembly, install on the rod (12), in order, the roll pin (14), washer (13), spring (11), washer (9), packing gland (7) with O-rings, seal (5), piston assembly (3) with O-ring, spring (2), and roll pin (15).
 3. Insert the piston rod assembly in the cylinder (1) and secure with the retaining ring (10).
 4. Install the cylinder per Paragraph 7-65.

7-65. INSTALLATION OF BRAKE CYLINDER. (Refer to Figure 7-17.)

- a. Position brake cylinder (14) at its mounting points and secure in position with clevis pin (4 and 16). Safety clevis pins with cotter pins.
- b. Connect brake lines to cylinder fittings. Bleed brakes as explained in Paragraph 7-66 or 7-67.

7-66. BRAKE BLEEDING PROCEDURE (GRAVITY).

- a. On both main landing gear wheel brake assemblies, attach a clear plastic hose to the brake bleeders and extend into container partially filled with hydraulic fluid, MIL-H-5606. The ends of this hose should be submerged in the fluid. Open both bleeders approximately one and one-half to two turns.
- b. Fill the brake reservoir on the fire wall with hydraulic fluid, MIL-H-5606.
- c. Disconnect the toe brake cylinders from the pedal connection by removing clevis pin, washer and cotter pin.
- d. Invert toe brake cylinder to aid in releasing trapped air in the top of the cylinder.
- e. Check toe brake pedals in the cockpit to insure pedals are pulled full aft.
- f. Pull the hand brake handle, pumping the master cylinder very slowly approximately 25 times until fluid is observed passing through the clear plastic hoses at the wheel cylinder.

NOTE

Fluid level in the reservoir must be maintained to prevent air from entering in the line.

- g. Tighten both wheel bleeders.
- h. Pull hand brake until a firm handle is maintained.

7-67. BRAKE BLEEDING PROCEDURE (PRESSURE).

- a. Place a small clear plastic hose on the vent tube of the brake reservoir and place a second small clear plastic hose on the bleeder fitting on one main landing gear. Place the open ends of these tubes in a suitable container to collect the fluid overflow. Open the bleeder fitting one or two turns.
- b. On the other main gear, slide the hose of the pressure unit over the bleeder fitting then open the fitting one or two turns and pressure fill the brake system with MIL-H-5606 fluid.
- c. With fluid continually flowing through the brake system, SLOWLY and together actuate the hand brake and the toe brake pedal of the side being bled, several times, to purge the cylinders of air. On dual brake installations, both right and left pedals must be actuated.

NOTE

By watching the fluid pass through the plastic hose at the fluid reservoir and the bleeder fitting on the gear being bled, it can be determined whether any air is left in the system. If air bubbles are evident, filling of the system shall be continued until all the air is out of the system and a steady flow of fluid is obtained. Should the brake handle remain spongy, it may be necessary to disconnect the bottom of the toe brake cylinders (next to the pedal) and rotating the cylinder horizontally or even above horizontal and by use of the hand brake alone, purge the air from the system.

- d. Close the open bleeder fitting on the gear being bled. Close the open bleeder fitting to which the pressure hose is attached; then close the pressure unit and remove the hoses from the bleeder fittings. Check the brakes for proper pedal pressure. Replace the caps over the bleeder fittings.

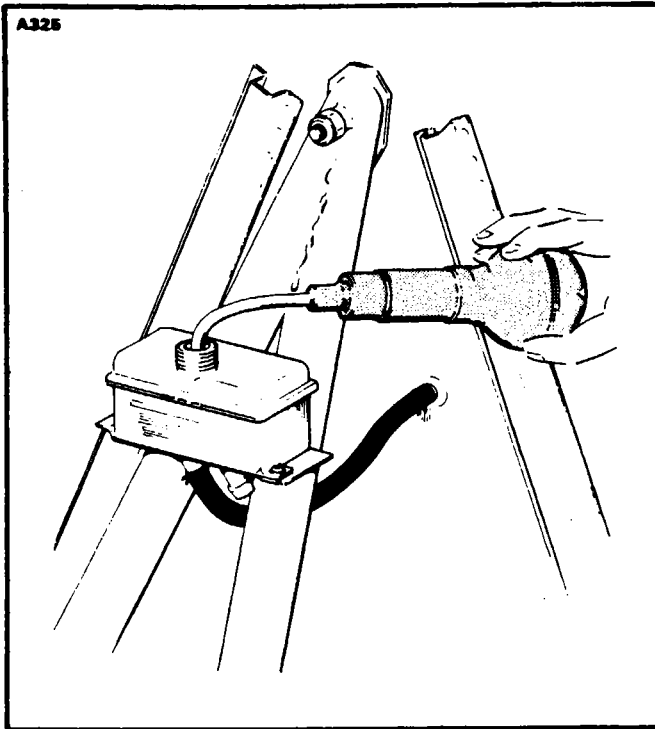

Figure 7-21. Brake Reservoir

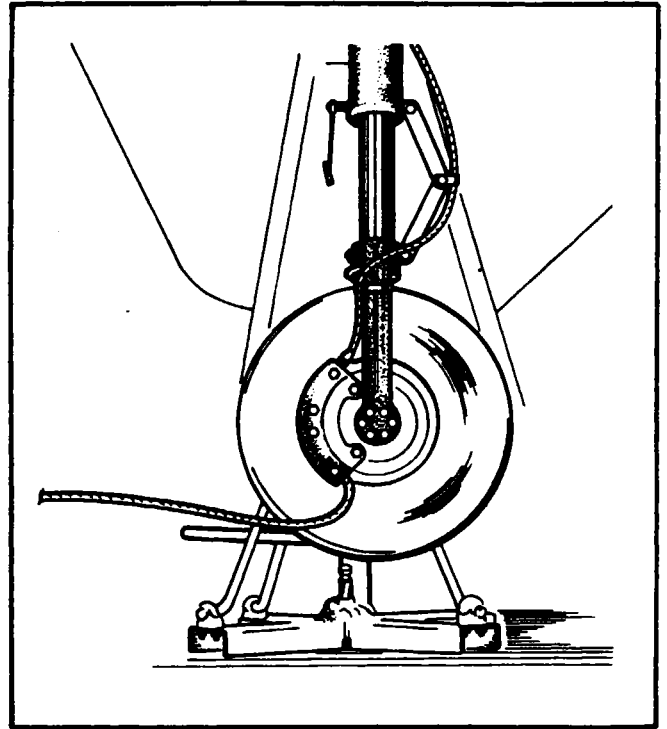

Figure 7-22. Bleeding Brake

NOTE

It may be necessary to remove any trapped air in the top of the wheel brake unit by applying pressure to the system with the brake hand lever and slowly opening the bleeder and release the hand lever.

- e. Repeat this procedure, if necessary, on the other gear.
- f. Drain excess fluid from the reservoir to fluid level line with a syringe.
- g. Make sure all lines are secure and all fittings are tight. It should be noted that on older master cylinders where the hole for the bleeder seat is tapered, the bleeder seat/fitting should be torqued at 75 to 90 inch-pounds. On the newer cylinders where there is a straight hole torque the seat till the O-ring seals the hole.

7-68. BRAKE SYSTEM LEAK CHECK.

- a. Pull for a good firm hand brake and lock parking brake mechanism. Allow system to stand for approximately 10 minutes; then by gripping the parking brake handle, it should not be able to be pulled aft further than the original set. Should the handle be able to be pulled towards the panel and feel spongy, a leak is present at some point in the system. This leak may appear at any one of the connections throughout the system or internally in the master brake cylinder or wheel brake assemblies.

TABLE VII-IV. TROUBLESHOOTING CHART (LANDING GEAR)

Trouble	Cause	Remedy
Green gear down lights dim though position light switch is off, and gear is down and locked.	Failed instrument panel light control switch. (Lights grounding through dimming resistor instead of through position light switch.)	Replace switch.
Green gear down lights fail to go out with gear in transit or retracted.	Gear down limit switch failed.	Replace switch.
Green gear down lights will go out and not dim when position light switch is turned on though gear is down and locked.	Green light ground dimming resistor open.	Replace resistor.
Gear warning light and horn fail to operate when throttle is near closed and landing gear is retracted.	Landing gear control circuit breaker open.	Reset circuit breaker and determine cause for open circuit breaker.
	Micro switch at throttle out of adjustment.	Adjust micro switch.
	Micro switch failed.	Replace switch.
	Warning horn and light circuit wire broken.	Check wiring.
Green downlock lights operate normally with position lights off but do not operate at all with position lights on.	Green lights dimming resistor open.	Replace resistor.

PIPER SENECA II SERVICE MANUAL

TABLE VII-IV. TROUBLESHOOTING CHART (LANDING GEAR) (cont)

Trouble	Cause	Remedy
Red gear unsafe light remains on with gear retracted and throttles advanced.	One or more of the landing gears not fully retracted. One or more gear up switches out of adjustment.	Check gears for full retraction. Adjust up switch (es) as necessary.
Landing gear doors fail to close completely.	Landing gear not retracting completely. Door retraction rods out of adjustment	Check adjustment of landing gear. Check adjustment door retraction rods.
Nose landing gear shimmy during fast taxi, take-off, or landing.	Internal wear in centering springs. Centering springs or bracket loose at mounting. Tire out of balance. Worn or loose wheel bearings. Worn torque link bolts and/or bushings.	Replace shimmy dampener. Replace necessary parts. Check balance and replace tire if necessary. Replace and/or adjust wheel bearings. Replace bolts and/or bushings.
Excessive or uneven wear on nose tire.	Incorrect operating pressure. Wear resulting from shimmy.	Inflate tire to correct pressure. Refer to proceedings for correction.
Nose gear fails to steer properly.	Oleo cylinder binding in strut housing.	Lubricate strut housing (Refer to Lubrication Chart). Cylinder and/or strut housing bushings damaged.

PIPER SENECA II SERVICE MANUAL

TABLE VII-IV. TROUBLESHOOTING CHART (LANDING GEAR) (cont)

Trouble	Cause	Remedy
Nose gear fails to steer properly. (cont)	One brake dragging. Steering arm roller sheared at top of strut. Steering bellcrank loose on attachment plate. Steering bellcrank bearing and/or bolt worn. Centering springs galling or binding.	Determine cause and correct. Replace defective roller. Readjust and tighten. Replace bearing and/or bolt. Replace.
Nose gear fails to straighten when landing gear extends.	Steering arm roller sheared at top of strut. Incorrect rigging of nose gear steering.	Replace defective roller. Check nose gear steering adjustment.
Nose gear fails to straighten when landing gear retracts.	Centering guide roller sheared. Damaged guide.	Replace roller. Replace guide.
Main landing gear shimmies during fast taxi, take-off, or landing.	Tire out of balance. Worn or loose wheel bearings. Worn torque link bolts and/or bushings.	Check balance and replace tire if necessary. Replace and/or adjust wheel bearings. Replace bolts and/or bushings.
Excessive or uneven wear on main tires.	Incorrect operating pressure. Wheel out of alignment (toe in or out). Lower side brace link out of adjustment, allowing gear to slant in or out.	Inflate tire to correct pressure. Check wheel alignment. Check gear adjustment.

PIPER SENECA II SERVICE MANUAL

TABLE VII-IV. TROUBLESHOOTING CHART (LANDING GEAR) (cont)

Trouble	Cause	Remedy
Strut bottoms on normal landing or taxiing on rough ground.	Insufficient air and/or fluid in strut.	Service strut with air and/or fluid.
	Defective internal parts in strut.	Replace defective parts.

1L19 THRU 1L24
INTENTIONALLY LEFT BLANK

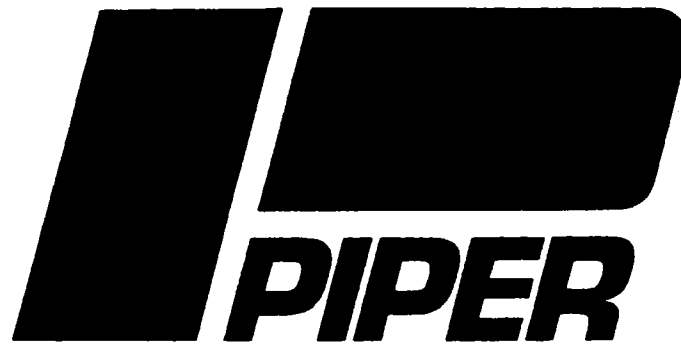

**SENECA II
SERVICE MANUAL**

CARD 2 OF 3

PA-34-200T SENECA II

PIPER AIRCRAFT CORPORATION

(PART NUMBER 761 590)

2A1

PIPER SENECA II SERVICE MANUAL

AEROFICHE EXPLANATION AND REVISION STATUS

Service manual information incorporated in this set of Aerofiche cards is arranged in accordance with the general specifications of Aerofiche adopted by the General Aviation Manufacturer's Association. Information compiled in this Aerofiche service manual is kept current by revisions distributed periodically. These revisions supersede all previous revisions, are complete Aerofiche card replacements, and supersede Aerofiche cards of the same number in the set.

Identification of revised material:

Revised text and illustrations are indicated by a black vertical line along the left-hand margin of the frame, opposite revised or added material. Revision lines indicate only current revisions with changes and additions to existing text and illustrations. Changes in capitalization, spelling, punctuation, indexing, physical location of the material, or complete page additions are not identified by revision lines.

Revisions to Service Manual 761 590 issued October 11, 1979 are as follows:

Effectivity	Publication Date	Aerofiche Card Effectivity
ORG791011	October 11, 1979	1, 2 and 3
PR800810	August 10, 1980	1, 2 and 3
PR810316	March 16, 1981	1, 2 and 3
PR821112	November 12, 1982	1, 2 and 3
PR831208	December 8, 1983	1, 2 and 3
IR860730	July 30, 1986	1
IR860920	September 20, 1986	1
IR870506*	June 12, 1987	1

This publication contains material revised as of December 8, 1983 (with three interim revisions effective July 30, 1986, September 20, 1986, and May 6, 1987).

* INTERIM CHANGE

Revisions appear in Table III-I of card 1. There are no other changes in this service manual. Please discard your current card 1 and replace it with this revised one. DO NOT DISCARD CARDS 2 or 3.

The date on Aerofiche cards must not be earlier than the date noted for the respective card effectivity. Consult the latest card in this series for current Aerofiche card effectivity.

TABLE OF CONTENTS

	AEROFICHE CARD NO. 1	GRID NO.
I	INTRODUCTION	1A13
II	HANDLING AND SERVICING	1A16
III	INSPECTION	1C23
IV	STRUCTURES	1D12
V	SURFACE CONTROLS	1F21
VI	HYDRAULIC SYSTEM	1I3
VII	LANDING GEAR AND BRAKE SYSTEM	1J5
AEROFICHE CARD NO. 2		
VIII	POWERPLANT	2A9
IX	FUEL SYSTEM	2D4
X	INSTRUMENTS	2E8
XI	ELECTRICAL SYSTEM	2F16
XII	ELECTRONICS	2I20
XIII	HEATING AND VENTILATING SYSTEM	2J6
AEROFICHE CARD NO. 3		
XIV	ACCESSORIES AND UTILITIES	3A6

PIPER SENECA II SERVICE MANUAL

LIST OF ILLUSTRATIONS

Figure		Aerofiche Grid No.
8-1.	Engine Cowling Installation	2A14
8-2.	Cowl Flap Installation	2A14
8-3.	Propeller Installation	2A16
8-4.	Typical Nicks and Removal Method	2A17
8-5.	Propeller Governor Installation	2A19
8-6.	Engine Installation	2A23
8-7.	Schematic Diagram of Turbocharger System	2B5
8-8.	Induction System Installation	2B6
8-8a.	Magneto Assembly	2B9
8-9.	Contact Spring Inspection	2B11
8-10.	Contact Points	2B12
8-11.	Impulse Coupling	2B12
8-12.	Flyweight Clearance of Impulse Coupling	2B13
8-13.	Rotor Holding Tool Installed	2B14
8-14.	Timing Kit Installed	2B14
8-15.	Cast-In Timing Marks	2B15
8-16.	Fabricated Pointer	2B15
8-17.	Engine Timing Marks	2B17
8-18.	Removing Spring From Lead Assembly	2B19
8-19.	Assembly Tool	2B20
8-20.	Assembly Tool Application	2B20
8-21.	Measuring Lead Assembly Length	2B20
8-22.	Ferrule Seating Tool	2B22
8-23.	Measuring Wire From Top of Ferrule	2B22
8-24.	Needle	2B22
8-25.	Installing Grommet Over Lead Assemblies	2B22
8-26.	Lead Assembly Installed in Grommet	2B23
8-27.	Wire Doubled Over For Installation of Eyelet	2B23
8-28.	Ignition Schematic	2B24
8-29.	Removing Frozen Spark Plug	2C3
8-30.	Lubrication System Maintenance Points	2C6
8-31.	Schematic Diagram of Fuel Injection System	2C8
8-32.	Fuel Injector Nozzle Assembly	2C9
8-33.	Engine Controls	2C10
8-34.	Idle Speed and Mixture Adjustment Points	2C12
8-35.	Sectional View of Altitude Compensating Fuel Pump Assembly	2C16
8-36.	Exhaust Bypass Valve Screw	2C18

PIPER SENECA II SERVICE MANUAL

LIST OF ILLUSTRATIONS (cont.)

Figure		Aerofiche Grid No.
9-1.	Fuel System Schematic	2D7
9-2.	Fuel Cell Installation	2D12
9-3.	Fuel Gauges	2D20
9-4.	Fuel Filter	2D20
9-5.	Fuel Selector Valve	2D23
9-6.	Slider Resistor Terminal	2E1
9-6a.	Resistor Set-Up/Test for Fuel Quantity Gauge	2E3
9-6b.	Maximum Deviation of Fuel Quantity Gauge Needle	2E4
10-1.	Gyro Pressure System	2E14
10-2.	Pitot-Static System, Serial Nos. 34-7570001 to 34-7670136 incl.	2E16
10-2a.	Pitot-Static System, Serial Nos. 34-7670137 and up	2E17
10-3.	Instrument Panel	2E18
11-1.	Switch Panel - For Models Without Primer System	2F21
11-1a.	Switch Panel - For Models With Primer System	2F22
11-2.	Removal of Slip Ring End Bearing	2G1
11-3.	Removal of Rectifier	2G1
11-4.	Testing Rotor for Ground	2G4
11-5.	Testing Rotor for Shorts	2G4
11-6.	Installation of Rectifier	2G5
11-7.	Terminal Assembly	2G6
11-8.	Slip Ring End Bearing Assembly	2G7
11-9.	Testing Alternator	2G7
11-10.	Regulator Diagram	2G10
11-11.	Testing Regulator	2G12
11-12.	Adjusting Regulator	2G13
11-13.	Application of Overvoltage Control	2G15
11-14.	Testing Overvoltage Control	2G15
11-15.	Exploded View of Starting Motor	2G17
11-16.	Turning Motor Commutator	2G18
11-17.	Testing Motor Armature for Shorts	2G18
11-18.	Testing Motor Fields for Grounds	2G19
11-19.	No-Load Test Hookup	2G19
11-20.	Stall Torque Hookup	2G20
11-21.	Landing Light Adjustment	2H1
11-22.	Adjusting Lift Detector Micro Switch	2H2

NOTE

Electrical Schematics for Section XI. see 2F18

12-1.	Two Year, Magnesium Battery Connections	2I22
12-2.	Garrett ELT Schematic	2I23
12-3.	Communications Components ELT Schematic	2J1
12-4.	Emergency Locator Transmitter Schematic (Narco)	2J1

Revised: 11/12/82

PIPER SENECA II SERVICE MANUAL

LIST OF ILLUSTRATIONS (cont.)

Figure		Aerofiche Grid No.
12-5.	ELT Portable Folding Antenna (Narco)	2J3
12-6.	ELT Using Fixed Aircraft Antenna (Narco)	2J3
13-1.	Cabin Heater, Defroster and Fresh Air Installation	2J9
13-2.	Heater and Combustion Air Blower Assembly (30,000 BTU)	2J12
13-3.	Heater and Combustion Air Blower Assembly (45,000 BTU)	2J13
13-4.	Diagramatic Cutaway of Heater to Show Whirling Flame Action	2J14
13-5.	Fuel Regulator and Shutoff Valve	2J16
13-6.	Top View - Duct Switch	2J16
13-7.	Wiring Diagram	2J20
13-8.	Primary Power Circuit	2J21
13-9.	Starting Power Circuit	2J22
13-10.	Spark Plug Fixture	2J24
13-11.	Wiring - Test Setup	2J24
13-12.	Spark Plug Gap Adjustment	2K1
13-13.	Ignition Unit Assembly	2K5
13-14.	Test Setup for Fuel Regulator and Shutoff Valve	2K8
13-15.	Heater Fuel Pump	2K9
13-16.	Suggested Design for Seal Plates, Plugs, and Caps for Combustion Tube Leakage Test	2K17
13-17.	Test Setup for Combustion Air Pressure Switch	2K17
13-18.	Exploded View of Heater Assembly (30,000 BTU)	2K21
13-19.	Exploded View of Heater Assembly (45,000 BTU)	2K22
13-20.	Exploded View - Combustion Air Blower and Motor Assembly (30,000 BTU)	2L3
13-21.	Exploded View - Combustion Air Blower and Motor Assembly (45,000 BTU)	2L4
13-22.	Suggested Setup of Heater Operation Test	2L6
13-23.	Wiring Connections for Heater Operation Test	2L6
13-24.	Spark Plug Gap Adjustment Tool	2L9

PIPER SENECA II SERVICE MANUAL

LIST OF TABLES

Table		Aerofiche Grid No.
VIII-I.	Propeller Specifications	2A18
VIII-II.	Propeller Chamber Pressure Requirements	2A18
VIII-III.	Engine Data	2A21
VIII-IV.	Fuel Flow vs. Engine Speed	2C17
VIII-V.	Metered Fuel Assembly Calibration	2C18
VIII-VI.	Limits - Fuel Flow vs. Brake H.P.	2C19
VIII-VII.	Troubleshooting Chart (Engine)	2C20
IX-I.	Fuel Quantity Sender Gauge Tolerances	2D20
IX-II.	Fuel Gauge Reading Tolerances	2E4
IX-III.	Gauge Readings/Resistance with Fuel in Tanks	2E5
IX-IV.	Troubleshooting Chart (Fuel System)	2E6
X-I.	Gyro Pressure System	2E12
X-II.	Directional Gyro Indicator	2E20
X-III.	Gyro Horizon Indicator	2E21
X-IV.	Rate of Climb Indicator	2E22
X-V.	Altimeter	2E23
X-VI.	Airspeed Tubes and Indicator	2F1
X-VII.	Magnetic Compass	2F2
X-VIII.	Manifold Pressure Indicator	2F5
X-IX.	Tachometer	2F6
X-X.	Engine Oil Pressure Gauge	2F7
X-XI.	Turn and Bank Indicator	2F8
X-XII.	Fuel Quantity Indicators	2F9
X-XIII.	Oil Temperature Indicators	2F10
X-XIV.	Exhaust Gas Temperature Gauge	2F13
X-XV.	Cylinder Head Temperature Gauge	2F14
X-XVI.	Fuel Flow Gauge	2F14
X-XVII.	Instrument Markings	2F15
XI-I.	Index to Electrical Schematics	2F18
XI-II.	Alternator Specifications	2G8
XI-III.	Starting Motor Specifications	2G21
XI-IV.	Hydrometer Reading and Battery Charge Percent	2G23
XI-V.	Troubleshooting Chart (Electrical System)	2H8
XI-VI.	Lamp Replacement Guide	2H20
XI-VII.	Electrical Wire Coding	2H21
XI-VIII.	Electrical Symbols	2H22
XI-IX.	Electrical System Component Loads	2H23
XIII-I.	Inspection	2K5
XIII-II.	Troubleshooting Chart (Janitrol Heater)	2L10
XIV-I.	Required Materials for Repair of Propeller Deicer	3B3
XIV-II.	Mixing of Materials	3B5
XIV-III.	Electrical Resistance	3B7

Revised: 3/16/81

2A7

PIPER SENECA II SERVICE MANUAL

LIST OF TABLES (cont.)

Table		Aerofiche Grid No.
XIV-IV.	Troubleshooting Chart (Propeller Deicer System)	3B9
XIV-V.	Operating Pressures	3B21
XIV-VI.	Materials and Supplies for Cold Repair	3B24
XIV-VII.	Troubleshooting Chart (Pneumatic Deicer System)	3C7
XIV-VIII.	Oxygen System Components Limits	3C13
XIV-IX.	Troubleshooting Chart (Oxygen System)	3C21
XIV-X.	Temperature Pressure Chart	3D1
XIV-XI.	Aluminum Tubing Torque	3D4
XIV-XII.	Blower System Wire Color Codes	3D24
XIV-XIII.	Troubleshooting Chart (Air Conditioner)	3E2

SECTION VIII

POWER PLANT

Paragraph		Aerofiche Grid No.
8-1.	Introduction	2A11
8-2.	Description	2A11
8-2a.	Standard Practices - Engines	2A11
8-3.	Troubleshooting	2A12
8-4.	Engine Cowling	2A12
	8-5. Removal of Engine Cowling	2A12
	8-6. Cleaning, Inspection and Repair of Engine Cowling	2A12
	8-7. Installation of Engine Cowling	2A12
8-8.	Engine Cowl Flaps	2A13
	8-9. Operation and Adjustment of Cowl Flaps	2A13
8-10.	Propeller	2A15
	8-11. Removal of Propeller	2A15
	8-12. Cleaning, Inspection and Repair of Propeller	2A15
	8-13. Installation of Propeller	2A17
	8-14. Checking Propeller Blade Track	2A19
8-15.	Propeller Governor	2A19
	8-16. Removal of Propeller Governor	2A19
	8-17. Installation of Propeller Governor	2A19
	8-18. Rigging and Adjustment of Propeller Governor	2A19
8-19.	Engine	2A22
	8-20. Removal of Engine	2A22
	8-21. Installation of Engine	2B1
8-22.	Engine Shock Mounts	2B1
	8-23. Replacement of Engine Shock Mounts	2B1
8-24.	Turbocharger	2B2
	8-24a. Turbocharger Nomenclature	2B2
	8-25. Removal of Turbocharger	2B4
	8-26. Installation of Turbocharger	2B4
	8-27. Adjustment of Turbocharger	2B6
8-28.	Induction System Air Filter	2B6
	8-29. Removal of Air Filter	2B6
	8-30. Cleaning Induction Air Filter	2B6
	8-31. Installation of Air Filter	2B7
8-32.	Alternate Air Door	2B7
8-33.	Ignition System	2B7
8-34.	Magnetos	2B7
	8-35. Inspection of Magnetos	2B8
	8-36. Removal of Magneto	2B10
	8-37. Magneto Timing Procedure (Internal Timing)	2B10
	8-38. Magneto Installation and Timing Procedure (Magneto to Engine)	2B14

Revised: 8/10/80

Paragraph		Aerofiche Grid No.
8-39.	Harness Assembly	2B17
	8-40. Inspection of Harness	2B17
	8-41. Removal of Harness	2B18
	8-42. Maintenance of Harness	2B18
	8-43. Installation of Harness	2C2
8-44.	Spark Plugs	2C2
	8-45. Removal of Spark Plugs	2C2
	8-46. Inspection and Cleaning of Spark Plug	2C3
	8-47. Installation of Spark Plugs	2C5
8-48.	Lubrication System	2C5
	8-49. Description	2C5
	8-50. Oil Filter Replacement	2C6
8-51.	Engine Fuel System	2C7
8-52.	Description	2C7
	8-53. Fuel Injection System Maintenance	2C7
8-54.	Fuel Injector Nozzle Assembly	2C9
	8-55. Removal of Fuel Injector Nozzles	2C9
	8-59. Cleaning and Inspection of Fuel Injector Nozzles	2C9
	8-57. Installation of Fuel Injector Nozzles	2C9
8-58.	Engine and Propeller Controls	2C11
	8-59. Rigging Throttle, Mixture and Governor Controls	2C11
	8-60. Engine Setup Procedures	2C12

SECTION VIII

POWER PLANT
TURBOCHARGED

8-1. INTRODUCTION. The purpose of this section is to provide instructions for the removal, minor repair, service and installation of the engine and components. For instructions on major repairs and overhauls, consult the appropriate publication of the component manufacturer.

8-2. DESCRIPTION. The PA-34-200T is powered by Teledyne Continental turbocharged, overhead valve, air cooled, horizontally opposed, direct drive, wet sump engines rated 200 hp at sea level.

Each engine is enclosed by cowling consisting of two side panels, an upper and lower section and a nose section. The cowl flap is an integral part of the lower cowl and is operated manually through a push-pull cable arrangement from the cockpit.

Propellers are Hartzell full feathering, constant speed each controlled by a governor mounted on the engine supplying oil through the propeller shaft at various pressures. Oil pressure from the governor moves the blades into low pitch (high RPM). The centrifugal twisting moment of the blade also tends to move the blades into low pitch. Opposing these two forces is a force produced by a compressed air charge between the cylinder head and the piston which tends to move the blades into high pitch in the absence of governor oil pressure. Thus, feathering is accomplished by compressed air.

Refer to Section IX for description of fuel system and primer operation.

8-2a. STANDARD PRACTICES - ENGINE. The following suggestions should be applied wherever they are needed when working on the power plant.

a. To insure proper reinstallation and/or assembly, tag and mark all parts, clips, and brackets as to their location prior to their removal and/or disassembly.

b. During removal of various tubes or engine parts, inspect them for indications of scoring, burning or other undesirable conditions. To facilitate reinstallation, observe the location of each part during removal. Tag any unserviceable part and/or units for investigation and possible repair.

c. Extreme care must be taken to prevent foreign matter from entering the engine, such as lockwire, washers, nuts, dirt, dust, etc. This precaution applies whenever work is done on the engine, either on or off the aircraft. Suitable protective caps, plugs, and covers must be used to protect all openings as they are exposed.

NOTE

Dust caps used to protect open lines must always be installed OVER the tube ends and NOT IN the tube ends. Flow through the lines may be blocked off if lines are inadvertently installed with dust caps in the tube ends.

d. Should any items be dropped into the engine, the assembly process must stop and the item removed, even though this may require considerable time and labor. Insure that all parts are thoroughly clean before assembling.

e. Never reuse any lockwire, lockwashers, tablocks, tabwashers or cotter pins. All lockwire and cotter pins must fit snugly in holes drilled in studs and bolts for locking purposes. Cotter pins should be installed so the head fits into the castellation of the nut, and unless otherwise specified, bend one end of the pin back over the stud or bolt and the other end down flat against the nut. Use only corrosion resistant steel lockwire and/or cotter pins. Bushing plugs shall be lockwired to the assembly base or case. Do not lockwire the plug to the bushing.

f. All gaskets, packings and rubber parts must be replaced with new items of the same type at reassembly. Insure the new nonmetallic parts being installed show no sign of having deteriorated in storage.

Revised: 8/10/80

2A11

POWER PLANT

g. When installing engine parts which require the use of a hammer to facilitate assembly or installation, use only a plastic or rawhide hammer.

h. Whenever adhesive tape has been applied to any part, the tape and all residue must be removed and thoroughly cleaned with petroleum solvents prior to being subjected to high temperature during engine run. This would also apply to parts that have corrosion preventive compounds applied.

8-3. TROUBLESHOOTING. Troubles peculiar to the power plant are listed in Table VIII-III, along with the probable causes and suggested remedies. When troubleshooting engines, propellers or fuel system, always ground the magneto primary circuit before performing any checks.

Troubles peculiar to the turbocharger system are listed in Table VIII-IV at the end of this section, along with the probable causes and suggested remedies.

8-4. ENGINE COWLING.

8-5. REMOVAL OF ENGINE COWLING. (Refer to Figure 8-1.) The procedure for removing the engine cowling is the same for both engines.

- a. Release the fasteners securing the two side access panels.
- b. Remove the fasteners securing the top cowl and then remove the top cowl.
- c. Disconnect the cowl flap control.
- d. Support the bottom cowl and remove the screws that attach the cowl to nose cowl, engine mount and nacelle.
- e. The nose cowl may be removed by removing the attaching screws and separating the two cowl halves.

8-6. CLEANING, INSPECTION AND REPAIR OF ENGINE COWLING.

- a. The cowl should be cleaned with a suitable solvent and then wiped with a clean cloth.
- b. Inspect the cowling for dents, cracks, loose rivets, damaged or missing fasteners and damaged fiberglass areas.
- c. Repair all defects to prevent further damage. Fiberglass repair procedures may be accomplished according to Fiberglass Repairs, Section IV.

8-7. INSTALLATION OF ENGINE COWLING. (Refer to Figure 8-1.)

- a. Position the two nose cowl halves on the front of the engine and secure with screw fasteners.
- b. Position the bottom cowl and secure with screw fasteners to the aft nacelle, engine mount and nacelle.
- c. Connect the cowl flap control.
- d. Position the top cowl and secure with attaching screw fasteners.
- e. Secure the side cowls to the upper and lower cowling.

8-8. ENGINE COWL FLAPS. The cowl flaps are all metal flaps located on the rear of the bottom cowl. The flaps are manually operated through a push-pull control from the cockpit. The cowl flaps are connected to the engine cowls with full length piano type hinges.

8-9. OPERATION AND ADJUSTMENT OF COWL FLAPS. The cowl flaps operate through three positions: closed, intermediate and open by control levers located on the console. When the control levers are in the up position, the flaps are closed. To operate the cowl flaps, depress the lock and move the lever down, releasing the lock after the initial down movement will allow the lock to stop the flap travel at the intermediate position. For full open position, depress the lock and move the control down; release the lock after the initial movement and continue to move the control down until the lock stops the travel of the control. To raise the cowl flaps reverse the procedure. The cowl flaps should be adjusted as follows:

- a. Place the control in the up position.
- b. Ascertain that the control lock is engaged.
- c. Check the cowl flap to visually determine that the flap is flush with the bottom of the engine cowl.
- d. If the flap is not flush, disconnect the push-pull control from the arm on the inboard side of the flap.
- e. Loosen the jam nut on the clevis end and adjust the clevis to get a flush fit between the cowl flap and engine cowl.
- f. Reconnect the control to the flap and operate the cowl flap through its full range a few times; then place the control in the closed position and visually check the flap to determine if it is flush with the engine cowl.
- g. If the cowl flap is not flush, repeat Steps d through f.
- h. When the adjustment is completed, tighten the clevis jam nut and secure the push-pull control to the cowl flap.

PIPER SENECA II SERVICE MANUAL

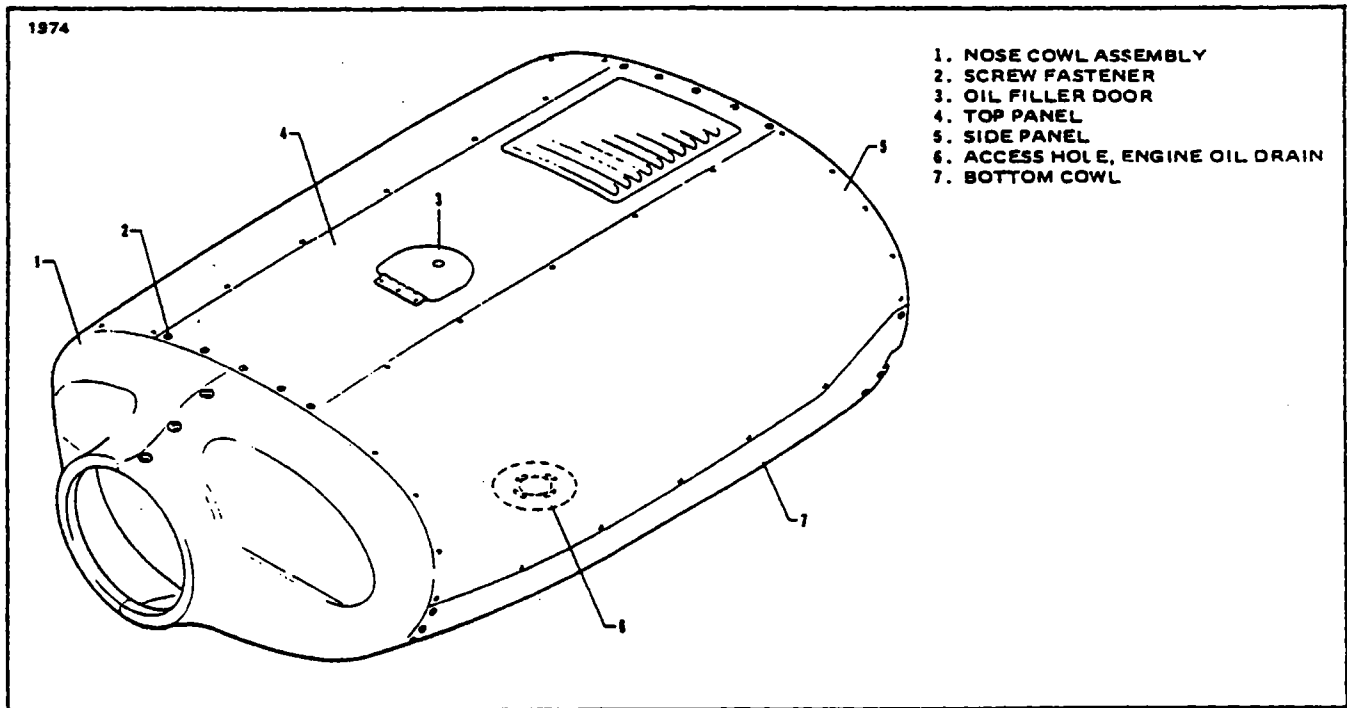

Figure 8-1. Engine Cowling Installation

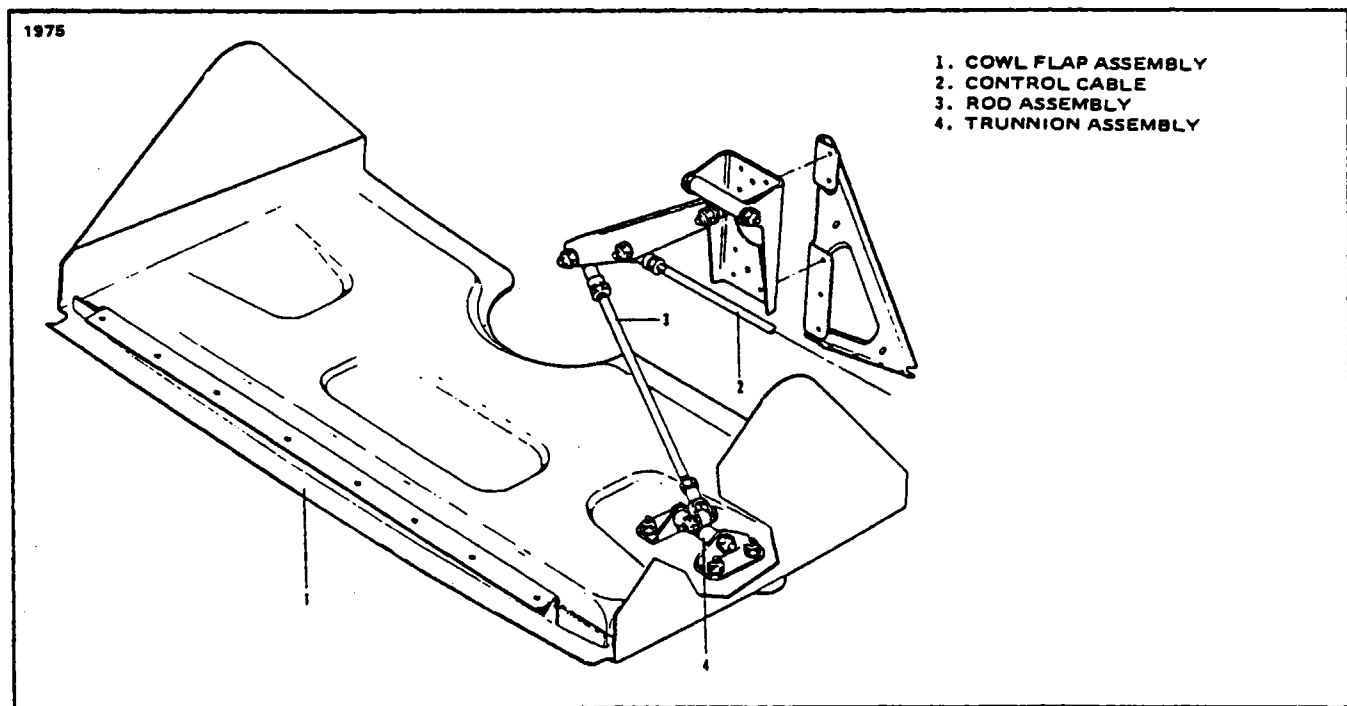

Figure 8-2. Cowl Flap Installation

8-10. PROPELLER.

8-11. REMOVAL OF PROPELLER. (Refer to Figure 8-3.)

WARNING

Before performing any work on the propellers, be sure the magneto and master switches are OFF and the mixture control is in the IDLE CUT-OFF position.

- a. Remove the hardware that attaches the nose cowl and remove the cowl. The top and side panels may be removed for greater accessibility.
- b. Remove the safety wire from the propeller mounting nuts and remove the nuts.
- c. Place a drip pan under the propeller to catch oil spillage and pull the propeller from the engine shaft.
- d. If the spinner and spinner bulkhead are to be removed, remove the spinner nose cap attaching screws and cap. Remove the spinner by removing the safety wire and check nut from the propeller at the forward end of the forward spinner bulkhead and the screws that secure the spinner to the aft bulkhead. The aft spinner bulkhead may be removed from the hub by removing the locknuts.

8-12. CLEANING, INSPECTION AND REPAIR OF PROPELLER.

NOTE

Do not attempt to disassemble the propeller any further than stated in this manual. For internal repairs and replacement of parts, the propeller should be referred to the Hartzell Factory or Certified Repair Station.

- a. Check for oil and grease leaks.
- b. Clean the spinner, propeller hub, and blades with a non-corrosive solvent.
- c. Inspect the hub parts for cracks.
- d. Steel hub parts should not be permitted to rust. Use aluminum paint to touch up, if necessary, or replat them during overhaul.
- e. Check all visible parts for wear and safety.
- f. Check blades to determine whether they turn freely on the hub pilot tube. This can be done by rocking the counterweights or blades back and forth through the slight freedom allowed by the pitch change mechanism. If they appear tight and are properly lubricated, the propeller should be disassembled by an authorized Service Center.
- g. Inspect the blades for damage or cracks. Nicks in the leading edges of blades should be filed out and all edges rounded, as cracks sometimes start from such places. Use fine emery cloth for finishing. (Refer to Figure 8-4 for propeller blade care.)
- h. Check the condition of the propeller mounting nuts and studs.
- i. Each blade face should be sanded lightly with fine sandpaper and painted, when necessary, with a flat black paint to retard glare. A light application of oil or wax may be applied to the surfaces to prevent corrosion.
- j. Grease the blade hub through the zerk fittings. Remove one of the two fittings for each propeller blade; alternate the next time. Apply grease through the zerk fitting until fresh grease appears at the fitting hole of the removed fitting. Care should be taken to avoid blowing out the hub gaskets.
- k. Check for air leaks by applying a soap solution around the air valve and stop adjustment nut. Internal leakage will show up as air flows through the piston rod.

PIPER SENECA II SERVICE MANUAL

1978

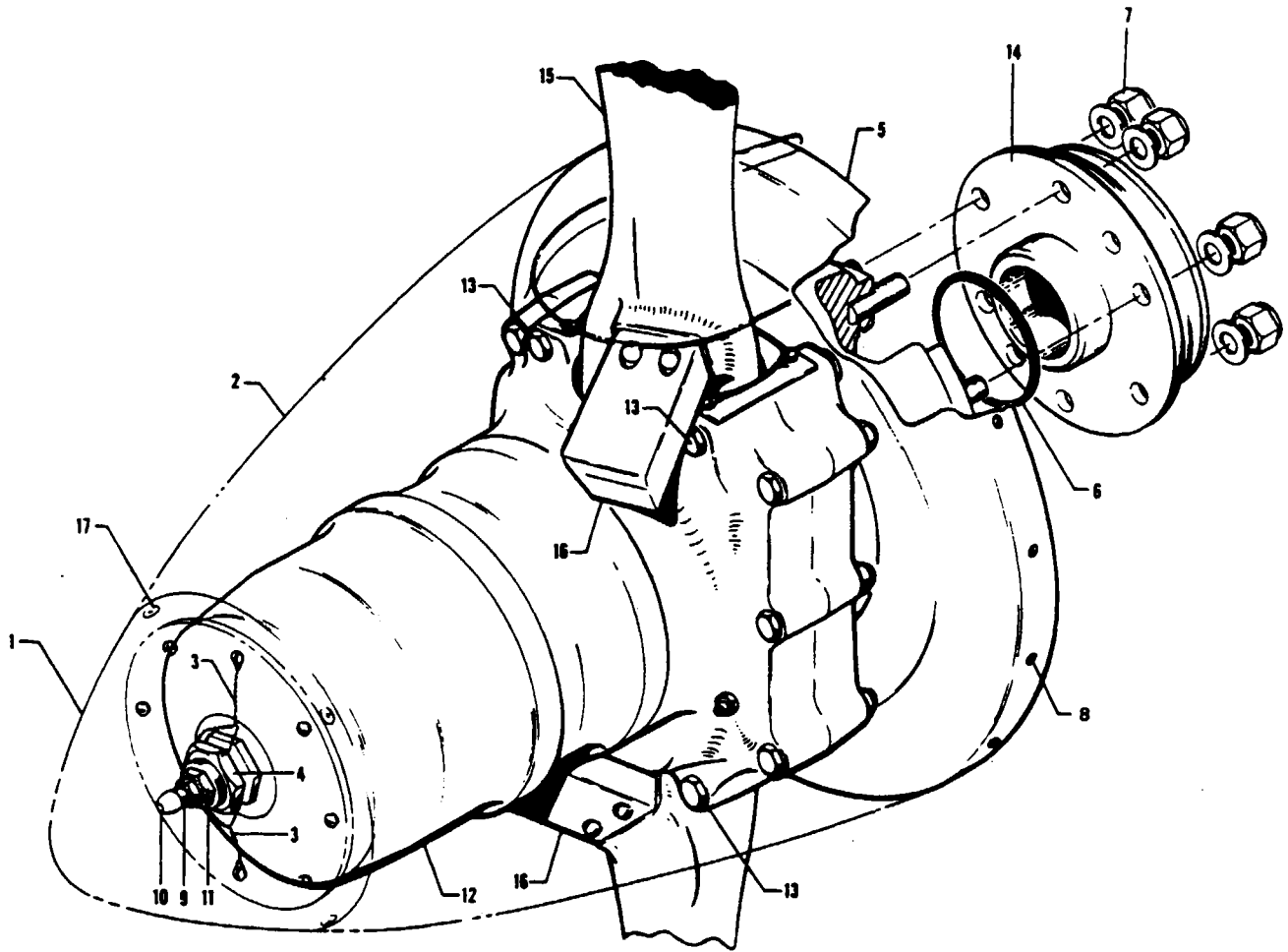

- 1. CAP, SPINNER
- 2. SPINNER
- 3. SAFETY WIRE
- 4. CHECK NUT, SPINNER
- 5. BULKHEAD, AFT
- 6. O-RING
- 7. MOUNTING NUT, PROPELLER
- 8. SCREW, SPINNER ATTACHMENT
- 9. AIR VALVE
- 10. CAP, AIR VALVE
- 11. LOW PITCH ADJUSTMENT
- 12. PROPELLER - R DOME
- 13. BOLT, BULKHEAD
- 14. ENGINE FLANGE
- 15. BLADE PROPELLER
- 16. COUNTERWEIGHT
- 17. SCREW, CAP ATTACHMENT

Figure 8-3. Propeller Installation

8-13. INSTALLATION OF PROPELLER. (Refer to Figure 8-3.)

WARNING

Before performing any work around the propellers be sure the magneto and master switches are OFF, and the mixture control is in the IDLE CUT-OFF position.

- a. Clean the propeller and engine flanges.
- b. Lubricate and install the O-ring in the propeller hub.
- c. Position the propeller as follows:
 1. On Hartzell propellers only, position the propeller and mount it to the engine flange. Tighten the mounting nuts a few threads at a time until all are tight. Torque the nuts 60 to 70 foot-pounds.
 2. On McCauley propellers only, with the #1 cylinder at the top dead center position, mount the propeller so that the dowel pin is between two blades and in the index hole closest to the upper crankcase split line. Torque the nuts 60 to 70 foot-pounds.
- d. Safety the propeller mounting nuts.
- e. Install spinner if removed and torque screws 35 to 40 inch-pounds.

CAUTION

To avoid spinner backplate cuff damage on McCauley props, the spinner must be installed prior to running engine.

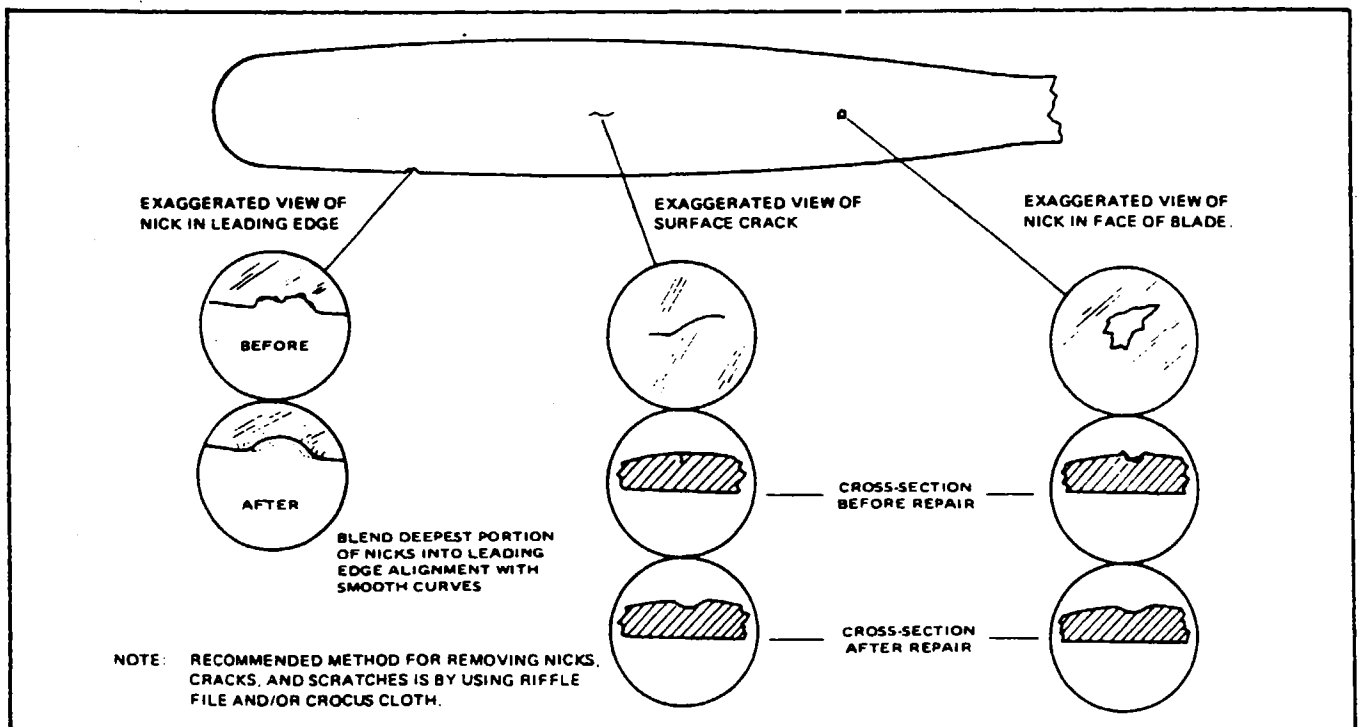

Figure 8-4. Typical Nicks and Removal Method

PIPER SENECA II SERVICE MANUAL

TABLE VIII-I. PROPELLER SPECIFICATIONS

Blade Angle Low Pitch (High RPM)	Hartzell 14.4° ± 0.2° ⁽¹⁾	McCauley 12.2° ± 0.2° ^{(1) (4)} or 11.5° ± 0.2° ^{(1) (5)} up to S/N 7870402 (inclusive) 12.0° ± 0.2° S/N 34-7970001 (Inclusive) and up ⁽⁶⁾ 81° to 83.5°
High Pitch (Low RPM)	79.3° ± 2.0° ⁽²⁾ or 80° to 81.5° ^{(2) (3)}	
Propeller RPM Setting Engine Static High RPM	2575 RPM max.	2575 RPM max.
Propeller Torque Limits Description	Required Torque (Dry)	
Spinner Bulkhead (Aft)	20-22 foot-pounds	20-22 foot-pounds
Propeller Mounting	60-70 foot-pounds	60-70 foot-pounds
Locknut (Low Stop)	15-20 foot-pounds	
Spinner Bulkhead Check Nut	15-20 foot-pounds	
Spinner Attachment Screws	35-40 inch-pounds	35-40 inch-pounds

(1) MEASURED AT 30 INCH STATION.
 (2) ON PROPELLER HUBS WITH SERIAL NUMBERS PRIOR TO AN3M3. EITHER SETTING IS APPROPRIATE. AT OWNER'S DISCRETION.
 (3) ONLY THIS SETTING CAN BE USED ON PROPELLER HUBS WITH SERIAL NUMBERS AN3M3 AND SUBSEQUENT.
 (4) LEFT ENGINE ONLY.
 (5) RIGHT ENGINE ONLY.
 (6) BOTH ENGINES

TABLE VIII-II. HARTZELL PROPELLER CHAMBER PRESSURE REQUIREMENTS WITH TEMPERATURE FOR COUNTERWEIGHT TYPE PROPELLERS

Temp. °F	PRESSURE (psi)	
	FOR PROPELLER HUBS: BHC-C2YF-2CKF and BHC-C2YF-2CLKF	FOR PROPELLER HUBS: BHC-C2YF-2CKUF and BHC-C2YF-2CLKUF
70 to 100	62 ± 2	22 ± 2
40 to 70	57 ± 2	17 ± 2
0 to 40	54 ± 2	14 ± 2
-30 to 0	49 ± 2	9 ± 2

NOTE: Do not check pressure or charge with propeller in feather position.

8-14. CHECKING PROPELLER BLADE TRACK. Blade track is the ability of one blade tip to follow the other, while rotating, in almost the same plane. Excessive difference in blade track - more than .0625 inch - may be an indication of bent blades or improper propeller installation. Check blade track as follows:

a. With the engine shut down and blades vertical, secure to the aircraft a smooth board just under the tip of the lower blade. Move the tip fore and aft through its full "blade-shake" travel, making small marks with a pencil at each position. Then center the tip between these marks and scribe a line on the board for the full width of the tip.

b. Carefully rotate propeller by hand to bring the opposite blade down. Center the tip and scribe a pencil line as before and check that lines are not separated more than .125 inch.

c. Propellers having excess blade track should be removed and inspected for bent blades, or for parts of sheared O-ring, or foreign particles, which have lodged between hub and crankshaft mounting faces. Bent blades will require repair and overhaul of assembly.

8-15. PROPELLER GOVERNOR.

8-16. REMOVAL OF PROPELLER GOVERNOR. The propeller governor is mounted on the lower left forward portion of the engine crankcase. Remove the governor as follows:

a. Remove the left side of the nose cowl to gain access to the governor.

b. Disconnect the governor control cable end from the governor control arm.

c. Remove the governor mounting nuts and withdraw the governor from the mounting pad. Cover the mounting pad to prevent foreign material from entering the engine.

8-17. INSTALLATION OF PROPELLER GOVERNOR.

a. Clean the mounting pad and the governor drive shaft thoroughly.

b. Coat the mounting gasket with Dow Corning release agent or equivalent.

c. Lubricate the drive shaft with engine oil and install the governor on the mounting pad.

d. Tighten the mounting nuts evenly and tighten to a final torque of 140 to 160 inch-pounds.

e. Connect the control cable to the control arm. Check to be sure the attachment bolt does not contact the governor body while moving the control arm through its full travel. Clearance should be .03 minimum.

8-18. RIGGING AND ADJUSTMENT OF PROPELLER GOVERNOR. (Refer to Figure 8-5.)

a. Start engine; park 90° to wind direction and warm in normal manner.

b. To check high RPM, low pitch setting, move the propeller control all the way forward. At this position the governor speed control arm (1) should be against the high RPM fine adjusting screw. With the throttle full forward, observe engine RPM, which should stabilize between 2500 and 2575 RPM. A takeoff must be conducted during which the engine RPM should reach 2575 RPM and remain steady.

c. If the engine RPM does not read 2575 RPM in flight, the high RPM setting must be adjusted as follows:

1. Land, shut down the engine and open the cowl door(s).

2. Adjust the governor by means of the fine adjustment screw for 2575 RPM. To do this, loosen the high RPM fine adjustment screw locknut and turn the screw in a clockwise direction to decrease engine speed or in a counterclockwise direction to increase engine speed.

NOTE

One revolution of the fine adjustment screw will increase or decrease the engine speed approximately 20 RPM.

PIPER SENECA II SERVICE MANUAL

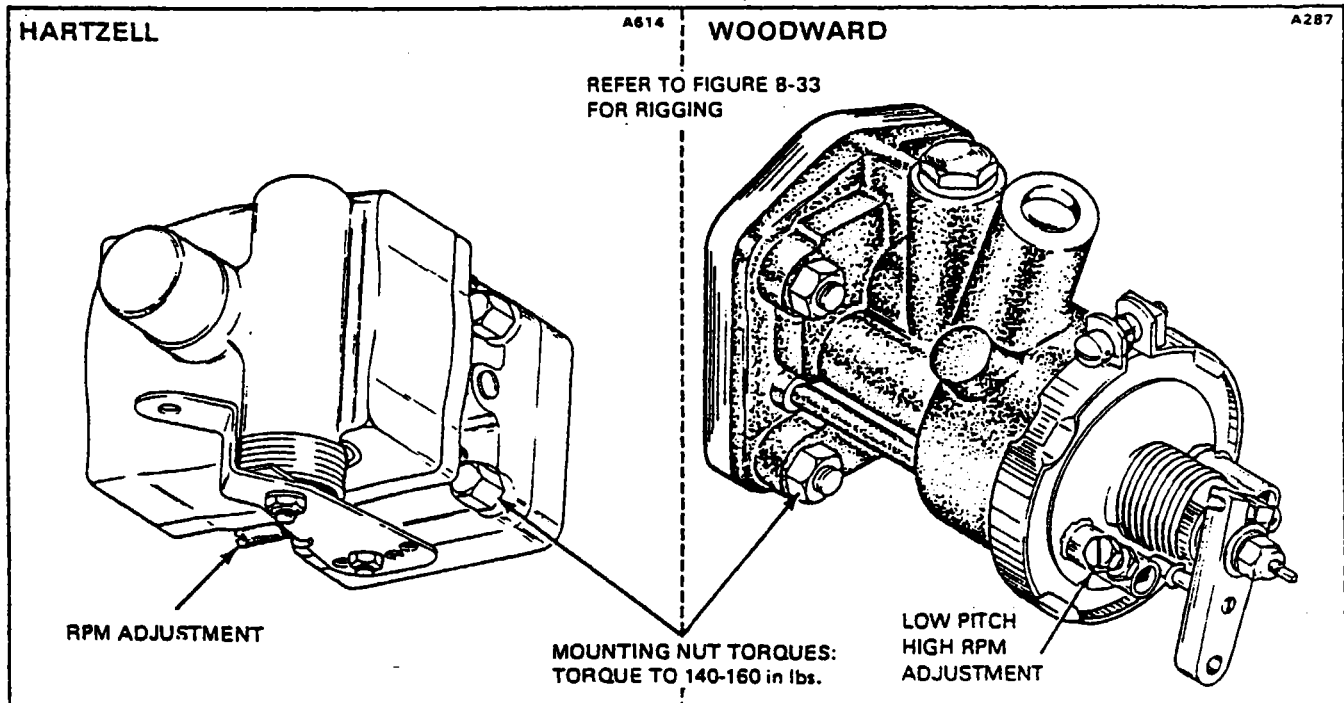

Figure 8-5. Propeller Governor

3. Secure the cowl door(s) and repeat Step b to ascertain proper RPM setting.

4. After setting the proper high RPM adjustment, run the self-locking nut on the fine adjustment screw against the base projection to lock.

d. With the high RPM adjustment complete, the control system should be adjusted so that the governor control arm will contact the high RPM stop when the cockpit control knob is .032 to .047 of an inch from its full forward stop. To adjust the control knob travel, disconnect the control cable end from the control arm; loosen the cable end jam nut and rotate the end to obtain the desired level clearance. Reconnect the cable end and tighten jam nut.

e. It is usually only necessary to adjust the high RPM (low pitch) setting of the governor control system, as the action automatically takes care of the positive low RPM (high pitch) setting.

TABLE VIII-III. ENGINE DATA

Model (Teledyne Continental)	TSIO-360E-1A or TSIO-360-EB ⁽¹⁾ LTSIO-360E-1A or LTSIO-360-EB ⁽¹⁾
Type Certificate Number	E9CE
Number of Cylinders	6 Horizontally Opposed
Bore (Inches)	4.44
Stroke (Inches)	3.88
Displacement (Cubic Inches)	360
Compression Ratio	7.5:1
Type of Propeller Drive, Flanged	Direct
Rated Horsepower at Sea Level, 2575 rpm	200
Fuel, Minimum Octane	100/130
Oil Sump Capacity	8 quarts
Oil Pressure (P.S.I.):	
Minimum	30
Normal	30-80
Maximum	80
Oil Temperature (°F):	
Minimum	100
Normal	100-200
Maximum	240
Probe Location	Above Oil Filter Element
Cylinder Head Temperature (°F) No. 2 cyl.:	
Minimum	240
Normal	200-400
Maximum	460
Magnetos	Bendix 25 Series
Left Bank	Fires 20° BTC Lower Right, Upper Left
Right Bank	Fires 20° BTC Lower Left, Upper Right
Firing Order:	
LTSIO-360-E or LTSIO-360-EB ⁽¹⁾	1-4-5-2-3-6
TSIO-360-E or TSIO-360-EB ⁽¹⁾	1-6-3-2-5-4
Spark Plugs (Shielded):	Refer to the latest revision of Teledyne Continental Aircraft Engine Service Bulletin M77-10.
Torque	
Alternator	12-volt, 65 ampere
Starter	12-volt, Prestolite
Engine Dry Weight With Accessories	385 pounds
Turbocharger	Rajay Model 325E10-1

(1) Replacement Engine on Aircraft models with serial numbers PA 34-7570001 and up.

8-19. ENGINE.

8-20. REMOVAL OF ENGINE. (Refer to Figure 8-6.)

- a. Turn off all electrical switches in the cockpit and disconnect the battery ground wire at the battery.
- b. Move the fuel selector valve in the cockpit to the OFF position.
- c. Remove the engine cowling. (Refer to Paragraph 8-5.)
- d. Remove the propeller. (Refer to Paragraph 8-11.)
- e. Disconnect the starter positive lead and ground lead at the starter.
- f. Disconnect the tachometer cable to the engine.
- g. Disconnect the governor control cable at the governor and cable attachment clamps.
- h. Disconnect the throttle and mixture cables from the fuel-air control unit.
- i. Disconnect the air conditioning compressor lines, if compressor is installed.
- j. Disconnect the cylinder temperature sender wire at No. 2 cylinder.
- k. Disconnect the fuel pump supply line and vent line from the engine.
- l. Disconnect the oil cooler lines.

NOTE

In some manner identify all hoses, wires and lines to facilitate installation. Open fuel, oil, vacuum lines and fittings should be covered to prevent contamination.

- m. Disconnect the magneto "P" leads at the magnetos.
- n. Disconnect the engine vent tube at the engine.
- o. Disconnect the engine oil temperature lead at the aft end of the engine.
- p. Untie the ignition harness, hoses and lines at the aft end of the engine.
- q. Disconnect the pneumatic pump lines at pump and remove fittings from pump.
- r. Disconnect the oil pressure line at the engine.
- s. Disconnect the fuel flow line at the left rear engine baffle.
- t. Disconnect the manifold pressure line at the left rear side of the engine.
- u. Disconnect the alternator leads and the cable attachment clamps.
- v. Attach a one-half ton (minimum) hoist to the hoisting straps and relieve the tension from the engine mounts.

NOTE

Place a tail stand under the tail of the airplane before removing an engine.

- w. Check the engine for any attachments remaining to obstruct its removal.
- x. Drain the engine oil.
- y. Remove the engine mounting bolts and lower mount assembly.
- z. Carefully raise the engine and pull forward to clear the mount. Check to be certain there are no connections remaining to obstruct removal of the engine, and remove the engine from the aircraft and place on a suitable stand.

PIPER SENECA II SERVICE MANUAL

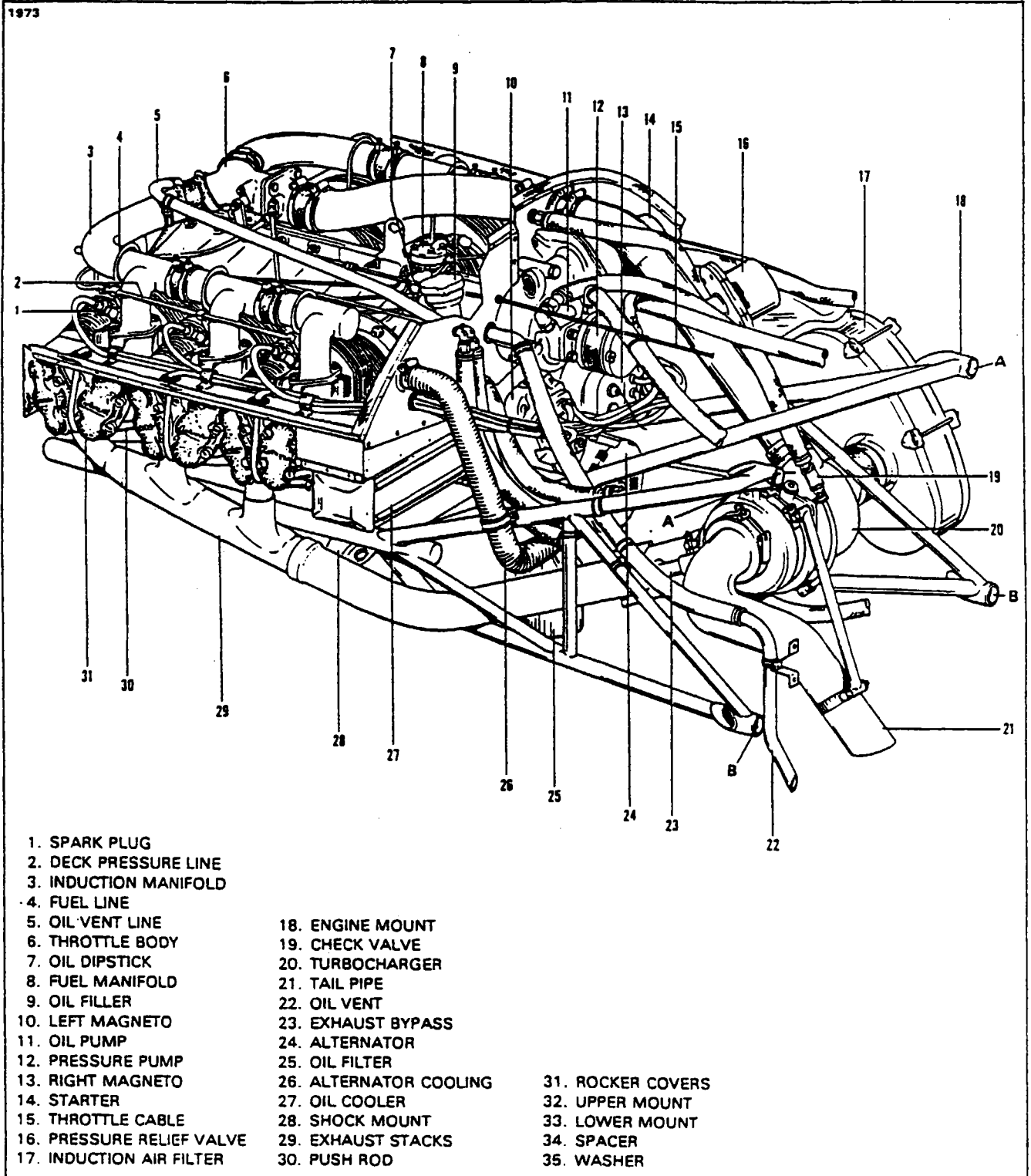
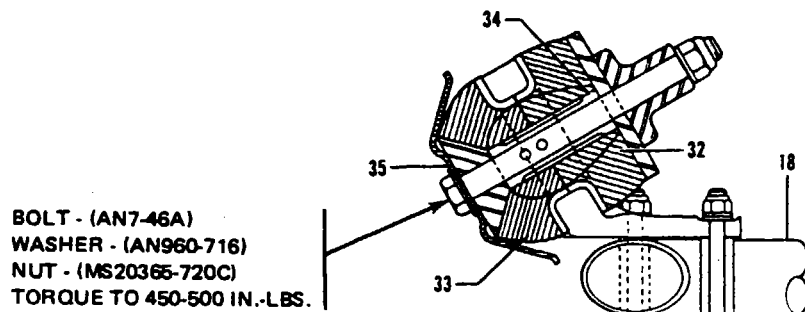

Figure 8-6. Engine Installation

Revised: 8/10/80

933



SHOCK MOUNT

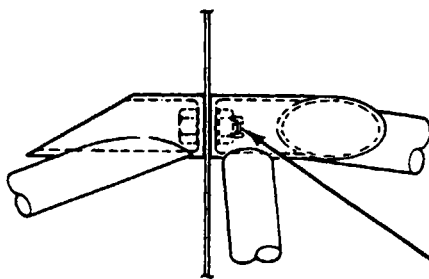

VIEW A

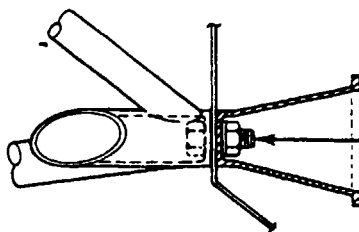

VIEW B

Figure 8-6. Engine Installation (cont.)

8-21. INSTALLATION OF ENGINE. (Refer to Figure 8-6.) Prior to installing the engine, be sure to install all items that were removed after the engine was removed from the aircraft.

NOTE

Remove all protective caps and identification tags as each item is installed.

- a. Install the shock mount in the engine mount and hoist the engine into position on the mount.
- b. Install the lower shock mount assemblies and mounting bolts. Torque the bolts 450 to 500 inch-pounds.
- c. Route and connect the throttle and mixture control cables and adjust.
- d. Route and connect the propeller governor control cable and adjust.
- e. Connect the alternate air cable and adjust.
- f. Reconnect all lines and hoses previously disconnected from the engine.

NOTE

Apply Lubon #404 to all male fuel system fittings. Do not allow to enter system.

- g. Route and connect the electrical leads to the appropriate connections on the engine.
- h. Connect the tachometer drive cable.

NOTE

Secure all cables, hoses and wires with clamps and Ty-strap in the same location as before removal.

- i. Connect the air conditioning compressor lines, if compressor is installed.
- j. Install the propeller and spinner per Paragraph 8-13.
- k. Service the engine with the proper grade and quantity of oil; refer to Section II.
- l. Be certain all switches are in the OFF position and connect the battery cables.
- m. Install the engine cowling per Paragraph 8-7.
- n. Make a final check of the security, location and installation of all lines, wires and cables.
- o. Perform an operational check of the engine; inspect for leaks and make final adjustments to engine controls as required.

NOTE

Check exhaust pipe clearance. Minimum clearance to structure and cowl flap door opening should be 0.50 of an inch.

8-22. ENGINE SHOCK MOUNTS.

8-23. REPLACEMENT OF ENGINE SHOCK MOUNTS. (Refer to Figure 8-6.)

- a. Remove the engine cowling per Paragraph 8-5.
- b. Relieve the engine weight on the mounts using a one-half ton hoist attached to the engine lifting points.
- c. Remove the four engine mounting bolts and the lower half of the mount assemblies.
- d. Carefully raise the engine just enough to remove the shock mounts. Check all lines, wires and cables for interference. Disconnect any lines and cables if necessary.

- e. Check all components for wear, damage or cracks and install new mounting kit.
- f. Lower the engine slowly and use mounting bolts to keep the components aligned.
- g. When the engine is supported by the mount, check the mounts for proper seating.
- h. Install the mounting bolt, nut, washer and torque 450 to 500 inch-pounds and safety.
- i. Reconnect any lines, wires or cables that were disconnected and install engine cowling.

8-24. **TURBOCHARGER.** The turbocharger system consists of a turbine and compressor assembly, ground adjustable waste gate assembly and the necessary hose and engine air intake ducts. The ground adjustable waste gate assembly allows exhaust gas to bypass the turbine and flow directly overboard. In the closed position, the waste gate valve diverts the exhaust gases into the turbine. The turbocharger requires little attention between overhauls. However, it is recommended that the items outlined in the Inspection Report, Section III be checked periodically.

8-24a. **TURBOCHARGER NOMENCLATURE.** Many unfamiliar terms may appear on the following pages of this manual. An understanding of these will be helpful, if not necessary, in performing maintenance and troubleshooting. The following is a list of commonly used terms and names as applied to turbocharging and a brief description.

TERM	MEANING
Supercharge	To increase the air pressure (density) above or higher than ambient conditions.
Supercharger	A device that accomplishes the increase in pressure.
Turbo-supercharger	More commonly referred to as a "Turbocharger" this device is driven by a turbine. The turbine is spun by energy extracted from the engine exhaust gas.
Compressor	The portion of a turbocharger that takes in ambient air and compresses it before discharging it to the engine.
Turbine	The exhaust driven end of the turbocharger unit.
Ground Boosted or Ground Turbocharged	These phrases indicate that the engine depends on a certain amount of turbocharging at sea level to produce the advertised horsepower. An engine that is so designed will usually include a lower compression ratio to avoid detonation.
Deck Pressure	The pressure measured in the area downstream of the turbo compressor discharge and upstream of the engine throttle valve. This should not be confused with manifold pressure.
Manifold Pressure	The pressure measured downstream of the engine throttle valve and is almost directly proportioned to the engine power output.
Normalizing	If a turbocharger system is used only to regain power losses caused by decreased air pressure of high altitude, it is considered that the engine has been "normalized."

Overboost

An overboost condition means that manifold pressure is exceeding the limits at which the engine was tested and FAA certified and can be detrimental to the life and performance of the engine. Overboost can be caused by malfunctioning controllers or improperly operating wastegate in the automatic system or by pilot error in a manual controlled system.

Overshoot

Overshoot is a condition of the automatic controls not having the ability to respond quickly enough to check the inertia of the turbocharger speed increase with rapid engine throttle advance. Overshoot differs from overboost in that the high manifold pressure lasts only for a few seconds. This condition can usually be overcome by smooth throttle advance. A good method for advancing the throttle is as follows. After allowing the engine oil to warm up to approximately 140° F. advance the throttle to 28" to 30" manifold pressure. hesitate 1 to 3 seconds and continue advancing to full throttle slow and easy. This will eliminate any overshoot due to turbocharger inertia.

Bootstrapping

This is a term used in conjunction with turbo machinery. If you were to take all the air coming from a turbocharger compressor and duct it directly back into the turbine of the turbocharger, it would be called a bootstrap system and if no losses were encountered, it would theoretically run continuously. It would also be very unstable because if for some reason the turbo speed would change, the compressor would pump more air to drive the turbine faster, etc. A turbocharged engine above critical altitude (wastegate closed) is similar to the example mentioned above, except now there is an engine placed between the compressor discharge and turbine inlet. Slight system changes caused the exhaust gas to change slightly, which causes the turbine speed to change slightly, which causes the compressor air to the engine to change slightly, which in turn again affects the exhaust gas, etc.

Critical Altitude

A turbocharged engine's wastegate will be in a partially open position at sea level. As the aircraft is flown to higher altitude (lower ambient pressures) the wastegate closes gradually to maintain the preselected manifold pressure. At the point where the wastegate reaches its full closed position, the preselected manifold pressure will start to drop and this is considered critical altitude.

8-25. REMOVAL OF TURBOCHARGER.

- a. Remove the engine cowling. (Refer to Paragraph 8-5.)
- b. Remove the turbocharger compressor and turbine assembly by the following procedure:
 1. Disconnect the oil supply and return lines from the center section of the turbo.
 2. Disconnect the air ducts from the compressor inlet and outlet, and the exhaust system from the turbine inlet and outlet.
 3. Disconnect the tail pipe support bracket at the turbocharger and remove the tail pipe and waste gate assembly.
 4. Remove the bolts that attach the turbocharger to the mounting bracket and remove the turbocharger assembly.
- c. The induction system overboost valve may be removed by the following procedure:
 1. Remove the four self-locking nuts, plain washers and bolts.
 2. Lift the overboost valve assembly from the induction tube.
 3. Remove the O-ring from the seating surface of the overboost mounting flange on the induction tube.

8-26. INSTALLATION OF TURBOCHARGER.

- a. Position the turbocharger assembly in the mounting bracket and secure with mounting hardware.
- b. Align the exhaust system with the turbo inlet and secure with clamp.
- c. Position the exhaust tail pipe and waste gate assembly to the turbocharger outlet. Fasten the tail pipe to the turbo outlet; do not tighten the clamp at this time.
- d. Position the tail pipe at a 34 degree angle (viewed from the side of the turbo and tail pipe) from the center of the turbo to the centerline of the tail pipe. Secure the tail pipe support bracket and mounting clamps at this time while maintaining this 34 degree angle.
- e. Connect the induction tube to the compressor outlet and the induction air filter assembly to the compressor inlet.
- f. If previously removed, install the overboost valve assembly by the following procedure:
 1. Install a new O-ring on the overboost mounting flange of the induction tube.
 2. Position the overboost valve assembly on the mounting flange with the holes in the valve aligning with the holes in the flange.
 3. Install the four bolts and secure with plain washers and self-locking nuts.
- f. Connect the oil supply and return lines to the turbocharger center section.
- g. Install the engine cowling. (Refer to Paragraph 8-7.)

INTENTIONALLY LEFT BLANK

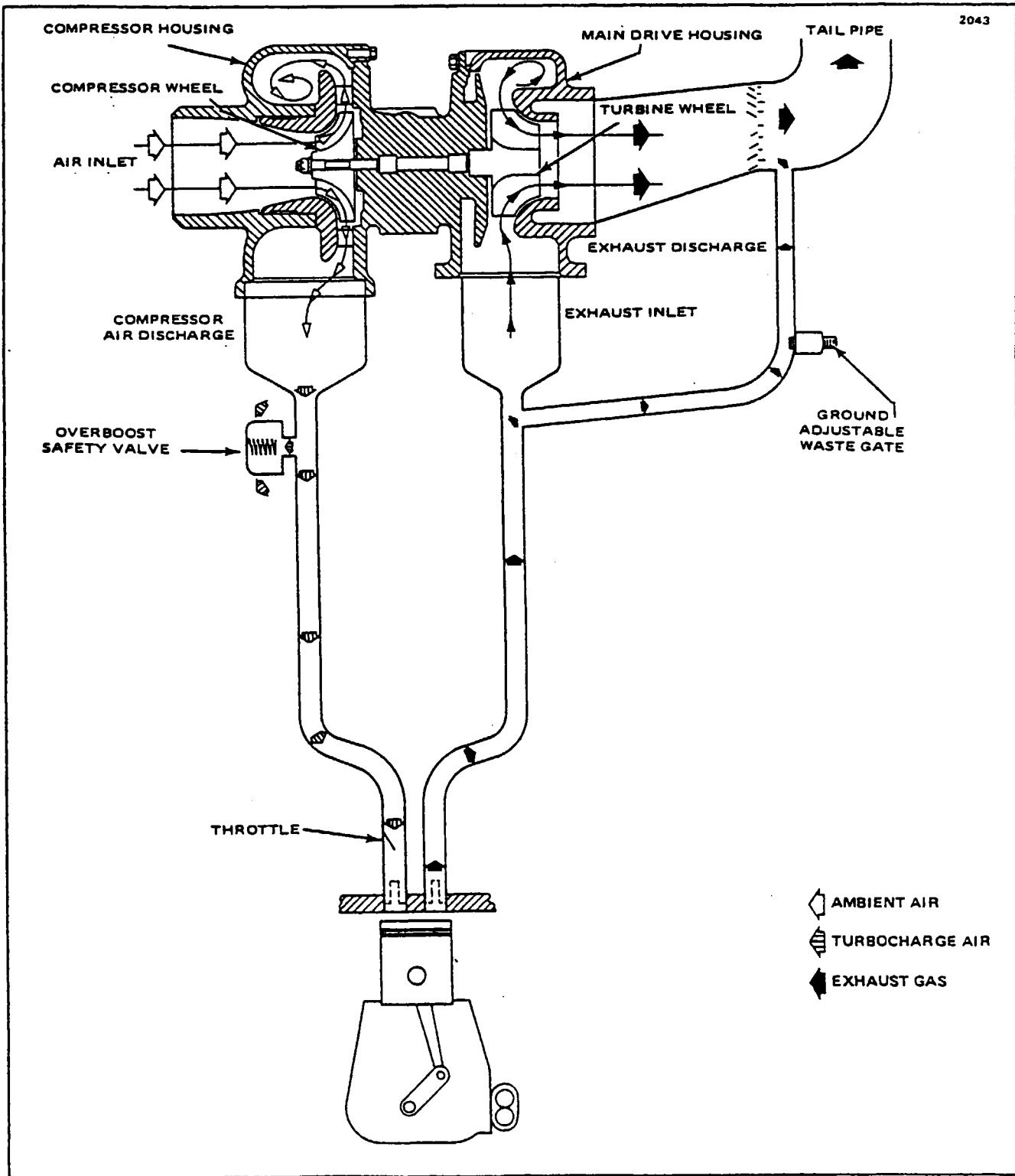

Figure 8-7. Schematic Diagram of Turbocharger System

Reissued: 10/11/79

POWER PLANT

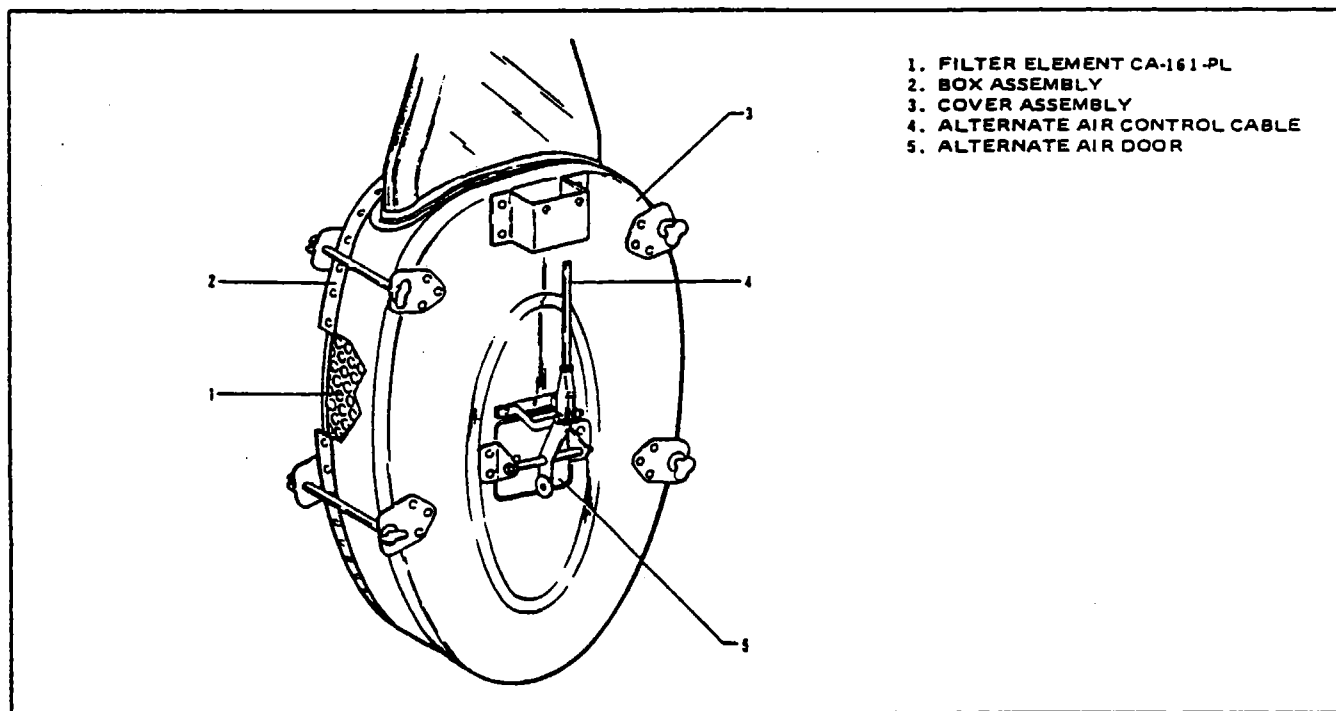

Figure 8-8. Induction System Installation

8-27. ADJUSTMENT OF TURBOCHARGER. (Refer to Paragraph 8-60, Step b.)

NOTE

A complete inspection of the power plant system should be performed before any turbo adjustments are made.

8-28. INDUCTION SYSTEM AIR FILTER.

8-29. REMOVAL OF AIR FILTER. (Refer to Figure 8-8.)

- a. Remove the side panel cowl on the right side of the engine.
- b. Release the stud fasteners; remove the filter cover and withdraw the filter element.

8-30. CLEANING INDUCTION AIR FILTER. The air filter element should be cleaned as often as it becomes dirty, everyday under severe dust conditions. The filter element should be replaced if any holes or tears exist. When cleaning the filter, it is good practice to remove the filter box assembly and clean with a solvent. Blow the assembly dry and wipe with a clean cloth to remove all traces of dirt.

- a. To clean the filter, rap gently on a hard surface to remove embedded debris. Be careful not to damage the sealing ends.

CAUTION

Never wash the filter element in any liquid or soak it in oil. Never attempt to blow off dirt with compressed air.

8-31. INSTALLATION OF AIR FILTER. (Refer to Figure 8-8.)

- a. Install the filter box assembly if removed.
- b. Position the filter element in the box assembly and secure the cover assembly with the stud fasteners.

NOTE

Check the induction system to be sure that no air leaks exist at any point that would allow unfiltered air to enter the engine.

8-32. ALTERNATE AIR DOOR. The alternate air door is located in the alternate air box to provide a source of air to the engine should there be an air stoppage through the filter system. The following should be checked during inspection:

- a. Check that air door seals are tight and the hinge and torsion spring are secure.
- b. Adjust the control cable to position the roller on the arm assembly clear of the door in the closed position. Check that when the cockpit control is in the closed position the door is properly seated in the closed position.
- c. Actuate the door by operating the control lever in the cockpit to determine that it is not sticking or binding.
- d. Check the cockpit control cable for free travel.

8-33. IGNITION SYSTEM.

8-34. MAGNETOS.

CAUTION

Ascertain that the primary circuits of both magnetos are grounded before working on the engine.

NOTE

The magneto service instructions in this manual cover minor repairs and timing. For further repairs and adjustments of the magnetos, it is recommended that the magneto manufacturer's service instructions be followed. (Refer to the latest revision of Continental Service Bulletin No. M78-8 for additional Ignition Maintenance.)

NOTE

A pressurized magneto retrofit kit is available. Installation of this kit (764 921v) will provide pressurized air to the magneto, thus improving ignition system operation and reducing the frequency of ignition system maintenance. (Refer to Parts Catalog.)

8-35. INSPECTION OF MAGNETOS.

a. After the first 25 hour and 50 hour periods, and periodically thereafter, the contact assemblies should be checked. Examine the points for excessive wear or burning. Points which have deep pits or excessively burned areas should be discarded. Examine the cam follower felt for proper lubrication. If necessary, points can be cleaned by using any hard finished paper. Clean breaker compartment with dry cloth.

b. If engine operating troubles develop which appear to be caused by the ignition system, it is advisable to check the spark plugs and wiring first before working on the magnetos.

c. Should the trouble appear definitely associated with the magneto, the most effective measure is to install a replacement magneto which is known to be in satisfactory condition and send the suspected unit to the overhaul shop for test and repair.

d. Should this not be possible, a visual inspection may disclose the source of trouble. Remove the harness outlet plate from the magneto. Inspect for the presence of moisture and foreign matter on the rubber grommet and high tension outlet side of the distributor block. Check height of block contact springs. The top of the spring must not be more than 0.422 of an inch below the top of the tower as shown in Figure 8-9. If the springs are broken or corroded, replace them.

e. Inspect the distributor block for cracks or burned areas. The wax coating on the block should not be removed. Do not use solvents.

f. Check for excess oil in the breaker compartment. If present, it may mean a bad oil seal or oil seal bushing at the drive end. Check the magneto manufacturer's overhaul procedure.

g. Remove the breaker cover and harness securing screws and nuts and separate cover from magneto housing. Check contact assemblies to see that cam follower is securely riveted to its spring. Examine the contact points for excessive wear or burning. Figure 8-10 shows how the average contact point will look when surfaces are separated for inspection. Desired contact surfaces have a dull gray, sandblasted (almost rough) or frosted appearance over the area where electrical contact is made. This means that points are worn in and mated to each other, thereby providing the best possible electrical contact and highest efficiency of performance.

h. Minor irregularities or roughness of point surfaces are not harmful (refer to Figure 8-10, center), neither are small pits or mounds, if not too pronounced. If there is a possibility of pit becoming deep enough to penetrate pad, Figure 8-10, right, reject contact assembly.

NOTE

No attempt should be made to stone or dress contact points. Should contact assembly have bad points or show excessive wear, the complete contact assembly should be replaced.

i. Check the condition of the cam follower felt. Squeeze felt tightly between thumb and forefinger. If fingers are not moistened with oil, re-oil using 2 or 3 drops of Bendix 10-86527 lubricant. Allow approximately 30 minutes for felt to absorb the oil. Blot off the excess with a clean cloth. Too much oil may foul contact points and cause excessive burning.

j. Inspect the felt washer in the distributor block for oil content. If the felt is dry, inspect the bronze bushing for wear. (Refer to the latest revision of the manufacturer's overhaul instruction.) Oil felt washer with Bendix Distributor Block Lubricant Part No. 10-391200. Blot excess oil from washer until flat surfaces take on a "frosted" appearance and seat washer in its recess in block.

k. Check the capacitor mounting bracket for cracks or looseness. Using the Bendix 11-1767-1, -2 or -3 Condenser Tester or equivalent, check capacitor for capacitance, series resistance and leakage. Capacitance shall be at least 0.30 microfarads. Series resistance should not be over 1 ohm at 500 kc.

A280

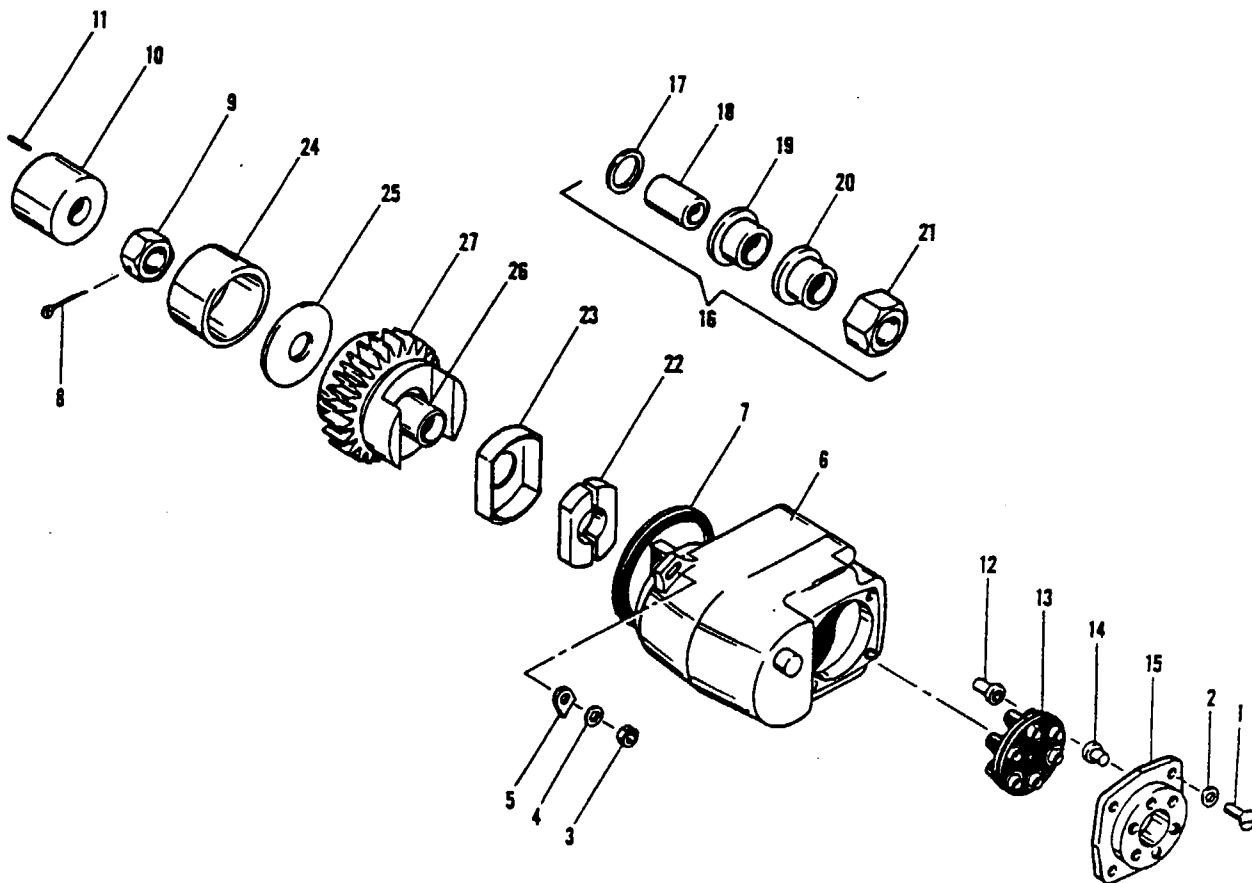

- 1. SCREW
- 2. LOCK WASHER
- 3. NUT
- 4. LOCK WASHER
- 5. HOLD DOWN WASHER
- 6. MAGNETO
- 7. GASKET
- 8. COTTER PIN
- 9. NUT
- 10. GEAR SUPPORT SHAFT
- 11. PIN
- 12. IGNITION CABLE EYELET
- 13. DISTRIBUTOR CABLE GROMMET

- 14. IGNITION CABLE FERRULE
- 15. DISTRIBUTOR CABLE PLATE
- 16. GROUND TERMINAL KIT
- 17. WASHER
- 18. INSULATING SLEEVE
- 19. INNER FERRULE
- 20. OUTER FERRULE
- 21. COUPLING NUT
- 22. COUPLING BUSHINGS
- 23. RETAINER
- 24. NEEDLE BEARING
- 25. WASHER
- 26. PILOT SLEEVE BUSHING
- 27. MAGNETO DRIVE GEAR

Figure 8-8a. Magneto Assembly

Reissued: 10/11/79

POWER PLANT

- l. Inspect coil leads for damaged insulations and terminals for tightness and soldered connection.
- m. Inspect impulse coupling parts for excessive wear. Particularly check clearance between cam and flyweights of the cam assembly. Measure the clearance between the cam flyweights using the shank of a new No. 18 drill (0.169 inch diameter). If the drill will fit between cam and flyweight as shown in Figure 8-11, the cam assembly must be replaced. Check clearance between both flyweights and the cam of each cam assembly.
 - n. Check the clearance between each flyweight and each stop pin as follows:
 1. Bend the end of a stiff piece of wire into a right angle 0.125 inch long (maximum).
 2. Hold magneto as shown in Figure 8-12. Pull heel of flyweight outward with the hooked wire and make certain that feeler gauge of 0.010 inch minimum thickness will pass between stop pin and the highest point of the flyweight.

NOTE

A true and accurate check of the clearance between flyweight and stop pin can only be obtained by pulling the flyweight outward as described above. Do not attempt the check by pushing in on flyweight at point "A."

- o. Check internal timing and reinstall and time magneto to engine.

8-36. REMOVAL OF MAGNETO.

- a. Remove the side access panel from the engine nacelle.
- b. Disconnect the "P" lead from the magneto.
- c. Remove the harness outlet plate from the magneto by removing the four attaching screws.
- d. Remove the two nuts and washers securing the magneto to the engine accessory housing.
- e. Pull the magneto from the engine.

8-37. MAGNETO TIMING PROCEDURE (INTERNAL TIMING). When installing or adjusting breaker points and before timing the magneto to the engine, it is important that the internal timing of the magneto be correct. The recommended method of checking the internal timing of the magneto is to use the Bendix 11-8150 Timing Kit using the procedure described in sub-paragraph a. However if a timing kit is not available, the cast in timing marks in the breaker housing and a fabricated pointer may be used as described in sub-paragraph b.

- a. Check the internal timing with the Bendix 11-8150 Timing Kit using the following procedure:
 1. Remove the magneto from the engine and remove the contact point cover.
 2. Loosen the nut securing the drive plate to the magneto shaft sufficiently in order to install the Bendix 11-8465 Rotor Holding Tool under the nut and flat washer as shown in Figure 8-13. Tighten the nut enough to hold the tool securely.
 3. Install the Bendix 11-8147 Plate Assembly to the breaker compartment of the magneto as shown in Figure 8-14.
 4. Remove the timing inspection plug from the top of the magneto and turn the rotating magnet in the direction of normal rotation until the painted chamfered tooth on the distributor gear is approximately in the center of the inspection window. Then turn it back until rotating magnet locates in its neutral position. Tighten adjustment knob of 11-8465 Rotor Holding Tool, holding the rotating magnet in the neutral position.

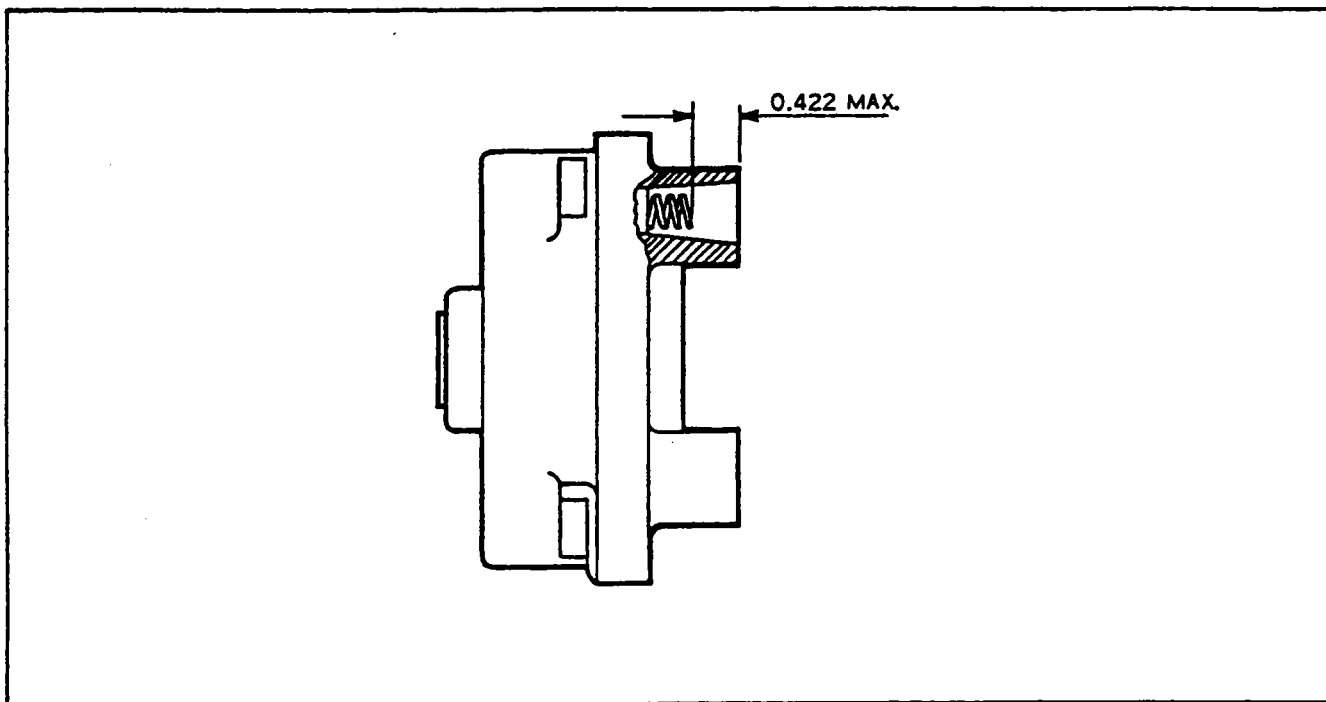

Figure 8-9. Contact Spring Inspection

CAUTION

Tighten adjusting knob of rotor holding tool only enough to hold magnet shaft firmly. Do not overtighten.

5. Install the Bendix 11-8149 Pointer Assembly on the cam screw and align pointer with the zero degree mark on the timing plate.

6. Loosen adjusting knob of rotor holding tool and turn rotating magnet in normal direction of rotation until pointer indexes with the respective 10° mark ("E" gap). Tighten adjustment knob of rotor holding tool.

7. With the Bendix 11-9110 Timing Light or equivalent, adjust main breaker contacts to just open at this position. Loosen holding tool and turn rotating magnet until breaker cam follower is on the high point of the cam lobe. Tighten holding tool and measure contact clearance. It must be 0.018 ± 0.006 . If not, readjust breaker and recheck to be sure that contacts will open within "E" gap tolerance $\pm 4^\circ$. Replace breaker assembly if "E" gap tolerances and contact clearance cannot be obtained.

8. After timing is complete, tighten breaker securing screws to 20 to 25 inch-pounds and recheck settings. Remove timing kit parts.

b. The internal timing can be checked without a timing kit using the cast in marks in the breaker compartment. These marks indicate "E" gap and limits (refer to Figure 8-15). The point in the center of the "E" gap boss indicates the exact "E" gap position. The width of the boss on either side of the point is the allowable tolerance of $\pm 4^\circ$. In addition to these marks, the cam has an indented line across its end. When the indented line is aligned with the mark at the top of the breaker housing, the rotating magnet is in its "E" gap position. Check the timing using the following procedure:

1. Install the Rotor Holding Tool 11-8465 under the drive shaft nut and washer as shown in Figure 8-13.

NORMAL POINT IS SMOOTH AND FLAT. SURFACE HAS DULL GRAY "SANDBLASTED" APPEARANCE.

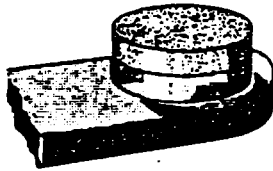

MINOR IRREGULARITIES - SMOOTH ROLLING HILLS AND DALES WITHOUT ANY DEEP PITS OR HIGH PEAKS. THIS IS A NORMAL CONDITION OF POINT WEAR.

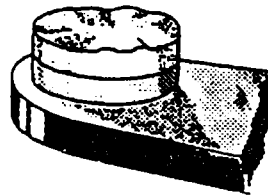

WELL DEFINED MOUND EXTENDING NOTICEABLY ABOVE SURROUNDING SURFACE. REJECT POINTS.

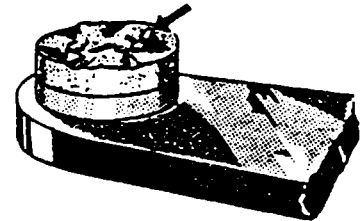

Figure 8-10. Contact Points

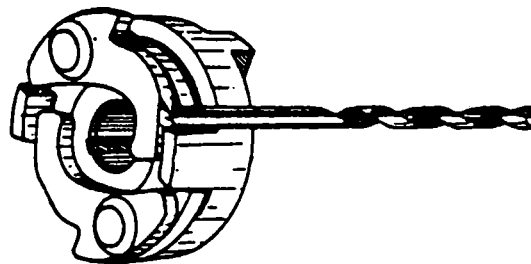

Figure 8-11. Impulse Coupling

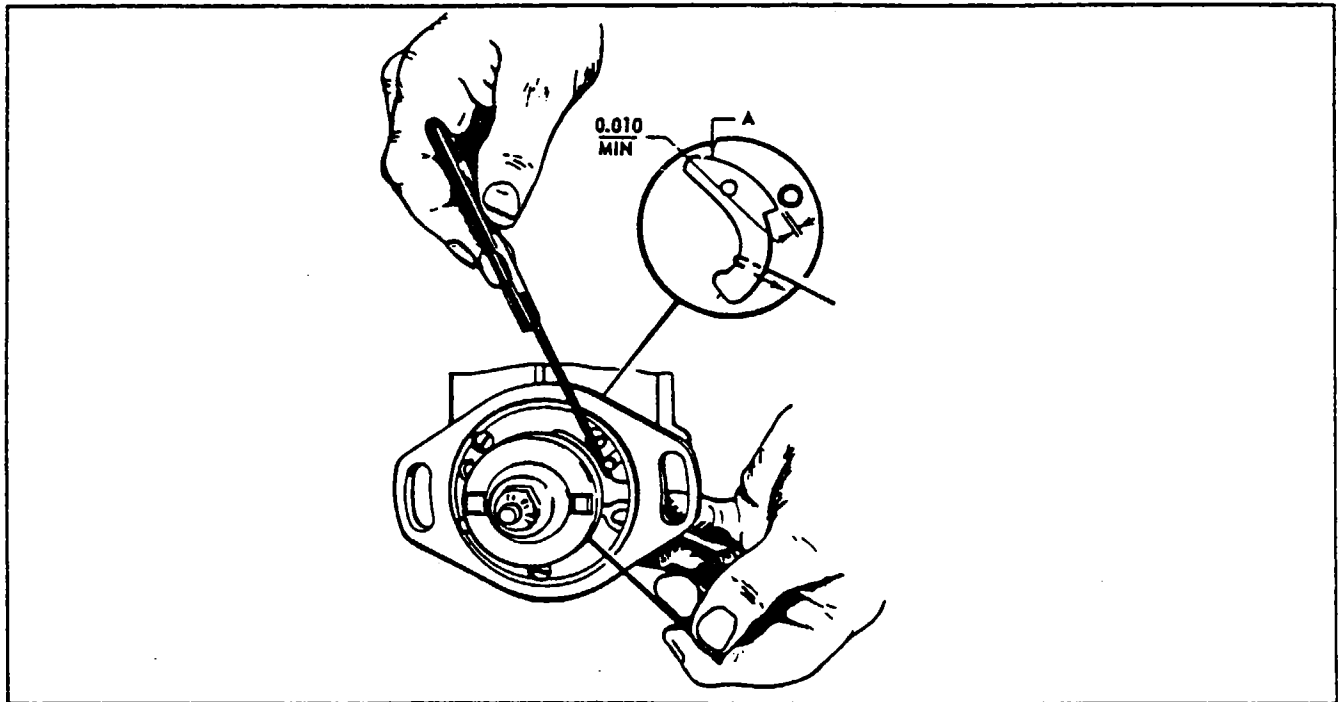

Figure 8-12. Flyweight Clearance of Impulse Coupling

NOTE

The rotor holding tool facilitates the timing procedure. However, it is possible to manually hold the shaft at the specified angle when setting the breakers.

2. Turn rotating magnet in direction of rotation until painted chamfered tooth of distributor gear is just becoming visible in timing window. Continue turning rotating magnet until line on end of cam is aligned with mark at top of breaker housing. (Refer to Figure 8-15.) Tighten adjusting knob of the holding tool to hold rotating magnet.
3. Fabricate a pointer as shown in Figure 8-16 and install the pointer under the cam screw so the pointer indexes in the center of "E" gap position.
4. Connect the 11-9110 Timing Light or equivalent across breaker assembly. Adjust breaker contacts to just open at this position.
5. Loosen holding tool and turn rotating magnet until cam follower is on high point of cam lobe. Tighten holding tool and measure contact clearance. It must be 0.018 ± 0.006 . If necessary, readjust breaker. Check to be sure contacts open within "E" gap tolerance. Replace breaker assembly if "E" gap tolerance and contact clearance cannot be obtained. Tighten breaker screws to 20 to 25 inch-pounds and recheck breaker settings.

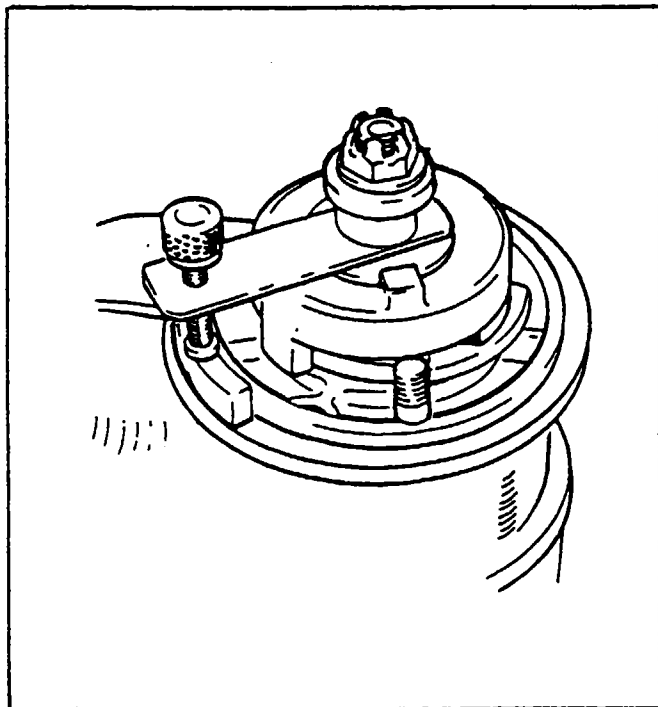

Figure 8-13. Rotor Holding Tool Installed

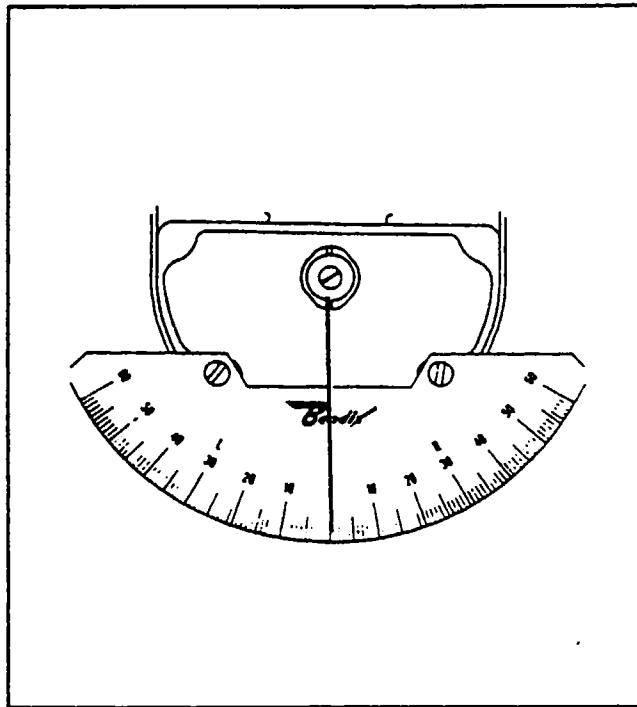

Figure 8-14. Timing Kit Installed

8-38. MAGNETO INSTALLATION AND TIMING PROCEDURE (MAGNETO TO ENGINE) (LTSIO IS COUNTER-ROTATING). (Refer to Figure 8-17.)

a. TSIO timing marks are on the outer edge of the crankshaft counterweight blade between No. 2 and No. 4 cylinders. The inspection plug between No. 2 and No. 4 cylinders on the left top side of the crankcase must be removed to view the marks on the crankshaft. (Refer to Sketch A.)

1. Plug one spark plug hole of the No. 1 cylinder and place a thumb over the other plug hole. Have a second person stand in front of the engine and turn the crankshaft in a counterclockwise direction until pressure is felt on the thumb. No. 1 piston is coming up on the compression stroke.

2. Remove the inspection hole plug and turn the crankshaft counterclockwise until the 20 degree BTC mark appears in the center of the inspection hole. A timing device as described in the latest revision of Service Bulletin M68-2, may also be used.

3. Remove the inspection hole plug from the magneto. Turn the magneto coupling until the painted chamfered tooth on the distributor gear is approximately centered in the inspection hole. Hold the magneto in its approximate installed position. Note carefully the position of the coupling drive lugs.

4. Lubricate the gear support shaft with clean lubricating oil and install the drive gear assembly so the slots of the coupling bushings will be in the approximate position for aligning with the drive coupling lugs on the magneto.

5. Insert the retainer into the gear hub slot. Apply a film of Lubriplate grease to each of the new rubber bushings and insert the bushings into the retainers, rounded long edges first.

6. Place a new gasket on the magneto flange. Install the magneto carefully so the drive coupling lugs mate with the slots of the drive bushings. Install and snug down the two sets of attaching screws. Do not tighten at this time.

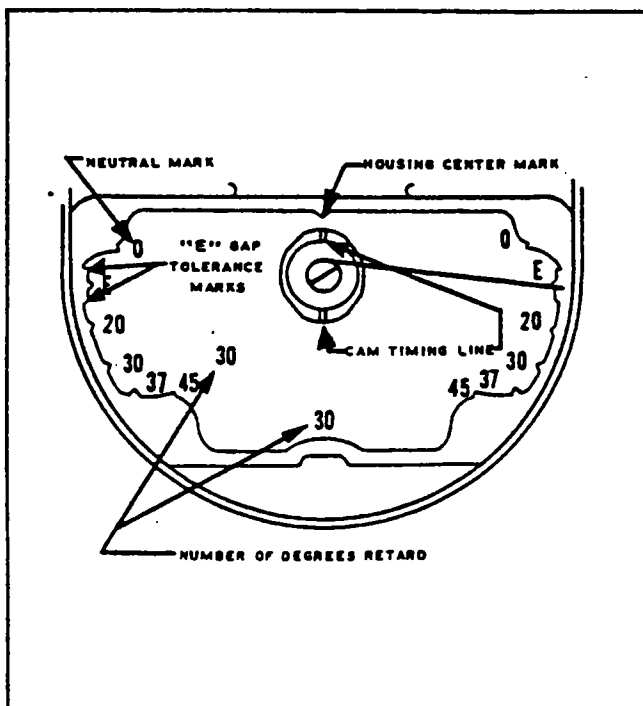

Figure 8-15. Cast-in Timing Marks

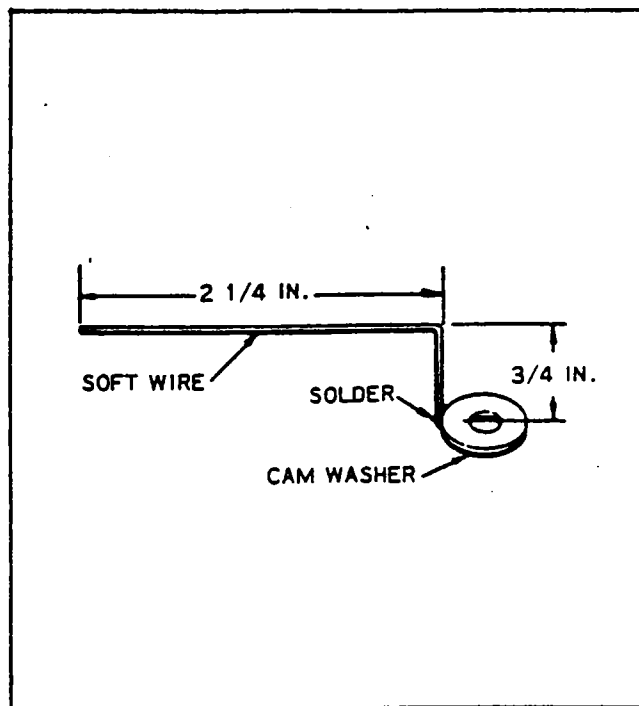

Figure 8-16. Fabricated Pointer

7. Breaker point opening may be checked by use of a suitable timing light. Tap the magneto case with a non-marring hammer, counterclockwise (from the rear) to make certain the points are closed. After the timing light indicates that the points are closed, tap the magneto lightly clockwise until the points are open. Tighten the magneto attaching nuts.

8. Check timing by backing up crankshaft approximately 5 degrees and tapping gently forward until the timing light indicates opening of breaker points. If timing is correct, the 20 degree mark (midway between the 16 and 24 stamped on the crankshaft) will appear in the center of the inspection hole. The crankshaft has punch marks in 2 degree increments with 16 and 24 at each end. Tighten the magneto attachment nuts and replace the plug in the inspection hole on top of the engine.

b. LTSIO timing marks are on the outer edge of the crankshaft propeller flange. (Refer to Sketch B.)

1. Plug one spark plug hole of the No. 1 cylinder and place a thumb over the other plug hole. Have a second person stand in front of the engine and turn the crankshaft in a clockwise direction until pressure is felt on the thumb. No. 1 piston is coming up on the compression stroke.

2. Hold a machinist square so its base is along the crankcase vertical parting line above the crankshaft and the arm of the square is pointing outward past the crankshaft propeller flange.

3. Turn the crankshaft clockwise until the 20 degree Before Top Center mark on the engine is now in the advanced ignition firing position.

4. Remove the inspection hole plug from the magneto. Turn the magneto coupling unit. The painted chamfered tooth on the distributor gear is approximately centered in the inspection hole. Hold the magneto in its approximate installed position. Note carefully the position of the coupling drive lugs.

5. Lubricate the gear support shaft with clean lubricating oil and install the drive gear assembly so the slots of the coupling bushings will be in the approximate position for aligning with the drive coupling lugs on the magneto.

PIPER SENECA II SERVICE MANUAL

6. Insert the retainer into the gear hub slot. Apply a film of Lubriplate grease to each of the new rubber bushings and insert the bushings into the retainers, rounded log edges first.

7. Place a new gasket on the magneto flange. Install the magneto carefully so the drive coupling lugs mate with the slots of the drive bushings. Install and snug down the two sets of attaching screws. Do not tighten at this time.

8. Breaker point opening may be checked by the use of a suitable timing light. Tap the magneto case with a non-marring hammer counterclockwise from the rear to make certain the points are closed. After the timing light indicates that the points are closed, tap the magneto lightly counterclockwise until the points are open. Tighten the magneto attachment nuts.

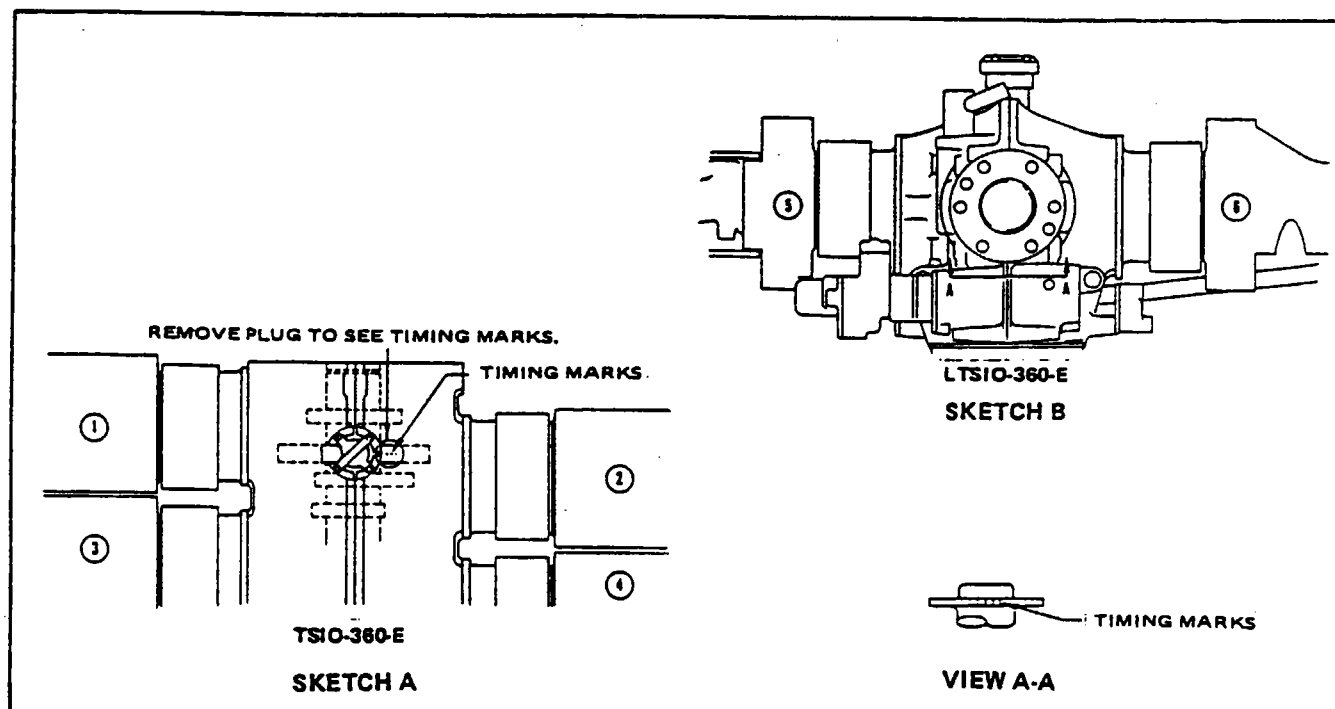

Figure 8-17. Engine Timing Marks

8-39. HARNESS ASSEMBLY.

8-40. INSPECTION OF HARNESS.

a. Check the lead assemblies for nicks, cuts, mutilated braiding, badly worn section or any other evidence of physical damage. Inspect the spark plug sleeves for chafing or tears and damaged or stripped threads on coupling nuts. Check the compression spring to see if it is broken or distorted. Inspect the grommet for tears. Check all the mounting brackets and clamps to see that they are secure and not cracked.

b. Should a harness problem be suspected, integrity of the harness wiring may be checked using an ohmmeter, buzzer, or other suitable device such as the Bendix/ECD High Tension Lead Tester Kits, P/N 11-8950 or 11-8950-1; check each lead for continuity. If continuity does not exist, harness wire is broken and must be replaced.

c. If an insulation failure is suspected, the condition of the insulation may be determined using the Bendix 11-8950 and the 11-8950-1 High Tension Lead Tester Kits manufactured by the Electrical Components Division, The Bendix Corporation, Sidney, New York.

d. Test Unit Preparation:

1. Install two "C" cells in the battery holder in accordance with correct position.
2. Check that red and black leads are open-circuited.
3. Depress PRESS-TO-TEST push-button switch.
4. Insure INDICATOR lamp flashes and GAP fires intermittently as long as PRESS-TO-TEST switch is depressed.
5. Interconnect both red and black high voltage leads and again depress PRESS-TO-TEST switch. INDICATOR lamp only should flash. GAP does not fire.

6. Disconnect black and red leads.
- e. Insulation Test:
 1. Attach clip of red high voltage test lead to ignition harness lead terminal.
 2. Attach black test lead clip to lead ferrule.
 3. Depress PRESS-TO-TEST push-button switch.
 4. Observe that INDICATOR lamp flashes and GAP fires intermittently as long as PRESS-TO-TEST switch is held depressed.
 5. Whenever INDICATOR lamp flashes and gap fails to fire, lead under test is defective.
 6. When testing leads which are installed on an engine, it may be found that distributed capacitance causes the tester to reject good leads if the tester and red test lead are allowed to lay in close physical contact with the engine parts. For best results, keep the tester and the red high voltage lead well clear of the grounded metal parts of the engine.
 7. On some engines, leakage through the magneto distributor to the magneto coil may occur if the distributor finger electrode is lined up with the lead under test. If this occurs, the tester will indicate a rejection. Before final rejection of a lead which has one end connected to the magneto, turn the engine slightly and repeat test to confirm the reading.
 - f. A second acceptable method for performing an insulation check is with a high voltage, direct current tester such as the TAKK Model 86 or 86A or an equivalent direct current tester capable of delivering a test potential of 10,000 volts. Connect ground lead of high voltage tester to outer shielding braid of a single lead. Connect plug terminal. Turn tester ON and apply 10,000 volts. The insulation resistance should be 100 megohms minimum. Proceed to check other leads of harness in the same manner.

8-41. REMOVAL OF HARNESS.

- a. Disconnect the clamps that secure the wires to the engine and accessories.
- b. Loosen the coupling nuts at the spark plugs and remove the insulators from the spark plug barrel well. Use caution when withdrawing the insulator so that the insulator spring will not be damaged.
- c. Place a guard over the harness insulators.
- d. Remove the harness assembly terminal plate from the magneto.
- e. Remove the harness from the airplane.

8-42. MAINTENANCE OF HARNESS.

- a. To replace contact springs, spring retainer assemblies or insulating sleeves, proceed as follows:
 1. Using a Bendix 11-7073 Needle or a mechanical pencil with the lead retracted, hook the end of the contact spring as shown in Figure 8-18.
 2. Using the needle or pencil, unscrew the spring.
 3. Slide the insulating sleeve and spring retainer assembly off the end of the lead assembly.
 4. Replace the defective component and reassemble as follows:
 - (a) Fabricate a tool as shown in Figure 8-19 for installing the insulating sleeves over the cable terminals.
 - (b) Push the tool through insulating sleeve and spring retainer assembly as shown in Figure 8-20. Screw the cable terminal into the tool.
 - (c) Work the insulating sleeve and spring retainer assembly into position over the cable and unscrew the tool. Install the contact spring on the cable terminal.

NOTE

It may be necessary to lubricate the cable and insulating sleeve with a thin film of Dow-Coming 200 (200,000 centi-stokes) or commercial grade alcohol to facilitate assembly.

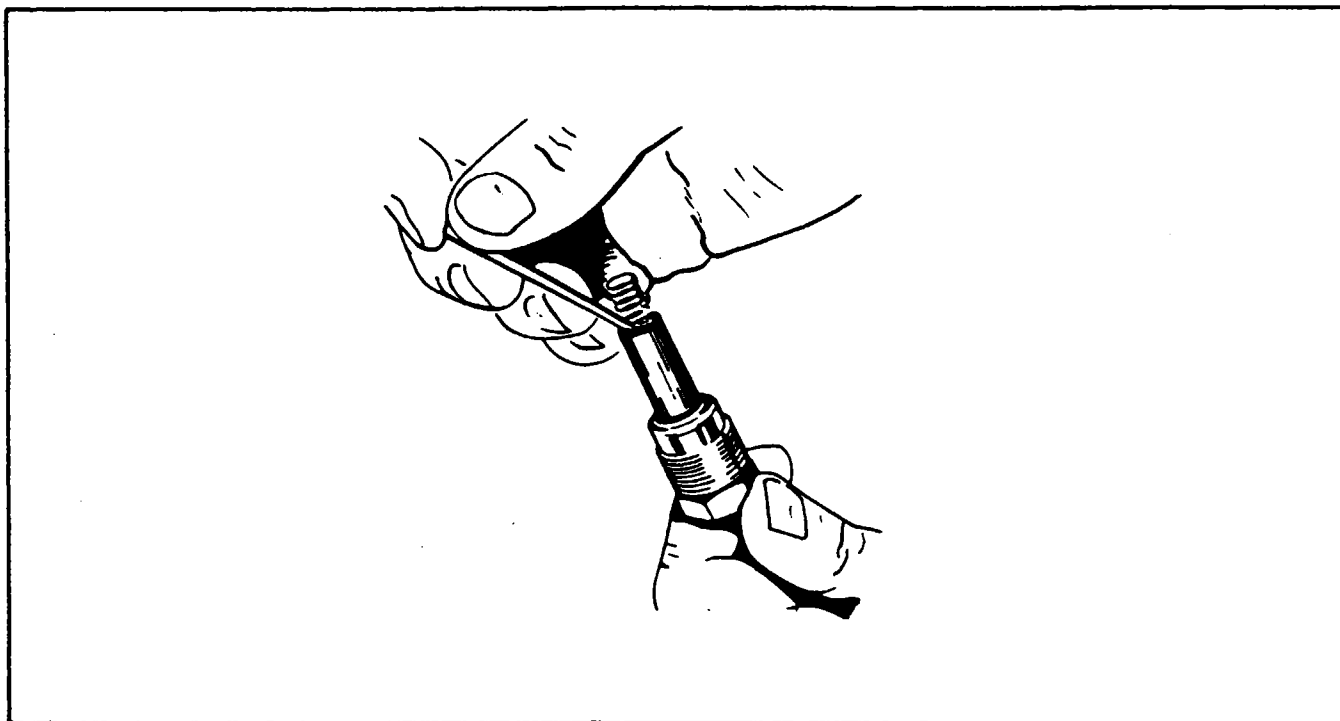

Figure 8-18. Removing Spring From Lead Assembly

- b. To replace one of the lead assemblies, proceed as follows:
1. Remove the clamps and brackets from the applicable lead assembly. Cut the cable ties from the assembly and discard them.
 2. Cut off the condemned lead flush with the outer surface of the cable outlet plate.
 3. Grip the eyelet of the lead with a pair of pliers and pull the short length of conductor out of grommet and cable outlet plate.
 4. Using a 3 inch long, 0.270 of an inch diameter drift applied at outer surface of plate, drive out tapered ferrule and remaining pieces of insulation and shielding.
 5. To determine what length the new lead assembly should be cut to, proceed as follows:
 - (a) Measure the length of the condemned lead assembly. Move the coupling nut back on the lead assembly and measure from the outer end of the ferrule at the spark plug end. (Refer to Figure 8-21.)

NOTE

Spare part leads are supplied in various lengths. Use a lead which is longer than, but nearest to, the desired length.

6. Cut the lead assembly to the length determined in Step 5. Mark the ferrule on the spark plug end of the lead with a metal stamp, scribe or rubber stamp to correspond with the correct cylinder number.
7. Starting at the spark plug location, thread the new cable through the grommets and clamps as necessary for the correct routing of the cut end of the cable to the magneto location.

PIPER SENECA II SERVICE MANUAL

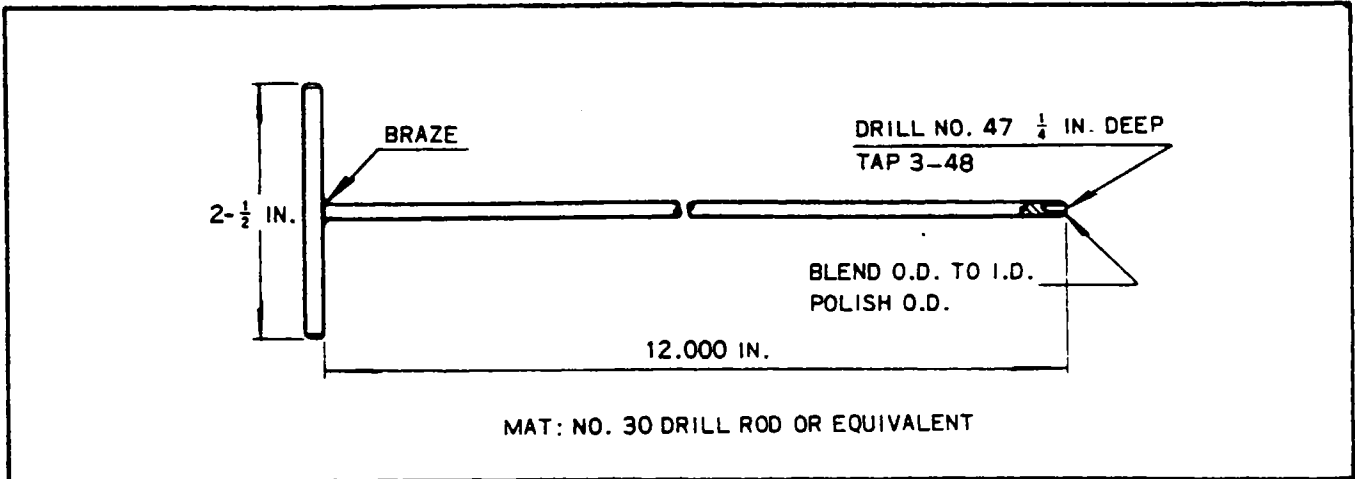

Figure 8-19. Assembly Tool

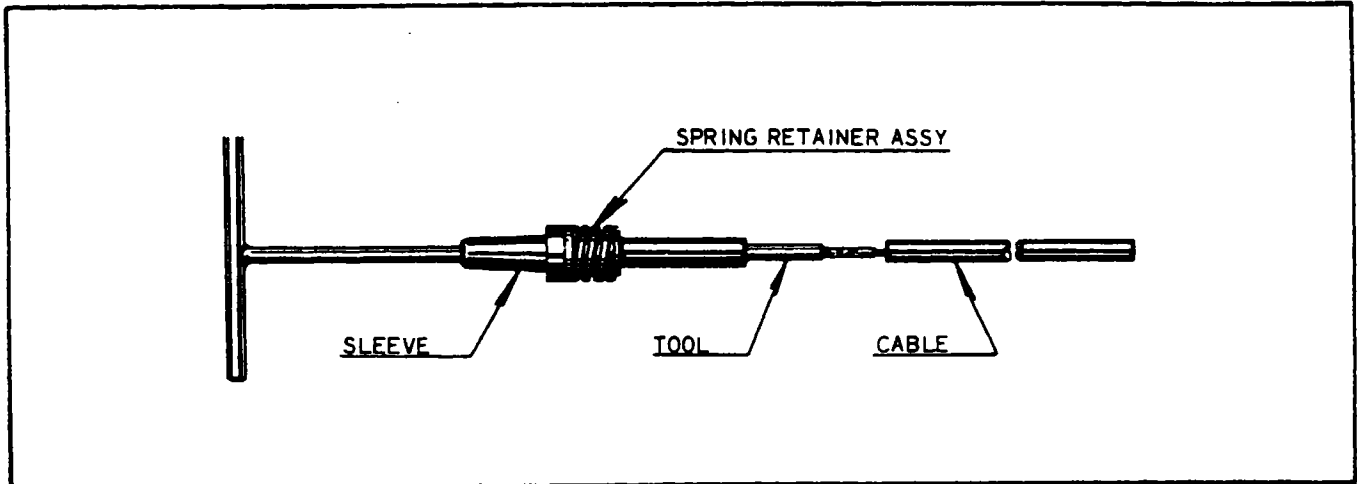

Figure 8-20. Assembly Tool Application

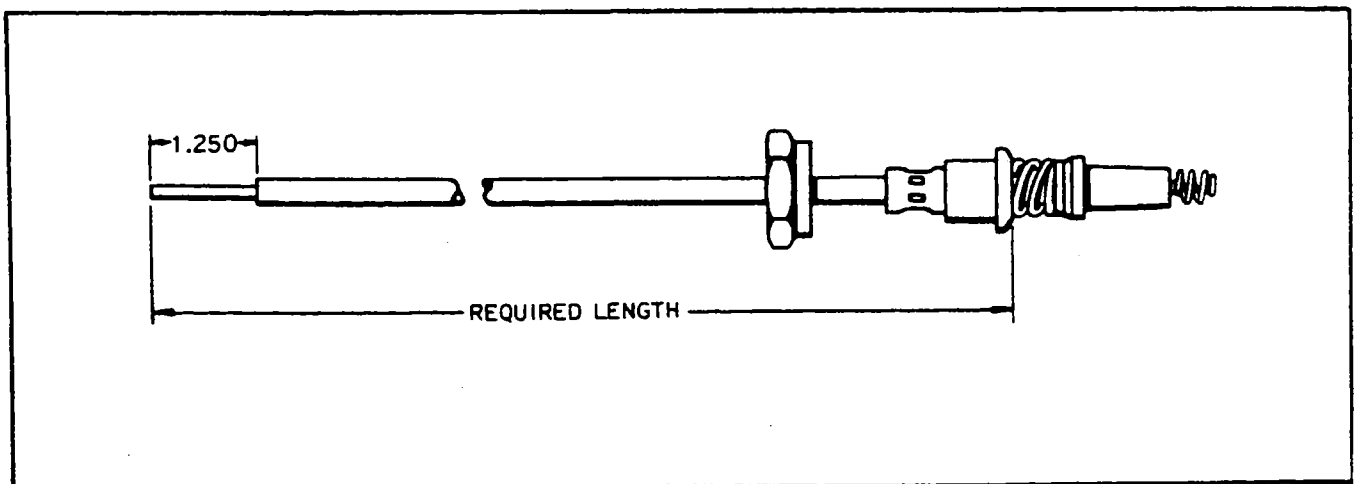

Figure 8-21. Measuring Lead Assembly Length

8. Remove the cable outlet plate from the magneto. Support the plate securely and using suitable cutting pliers, split and remove the eyelets from the leads adjacent to the lead being replaced. When splitting the eyelet, make certain that the wire strands are not cut. Removal of eyelets on adjacent leads will allow the grommet to be pulled away from the outlet plate to facilitate insertion of the new lead.

9. Assemble the lead to the cable outlet plate following the procedure in Steps 10 through 17.

CAUTION

Insure before every cutting or stripping procedure that braid has not worked back on lead by grasping lead in one hand and sliding the other hand firmly along lead toward the outlet plate. If braid is improperly located on lead, the lead may be trimmed to the wrong length.

10. Pass the lead through the proper hole in outlet plate. Position the Bendix 11-9596 or equivalent Braid Cutting Backup Tube between the braided shielding and insulation to protect the insulation. Cut enough braid from the lead to have 1-1/4 inch of insulation extending from end of braid.

CAUTION

Be sure the cutting backup tube is completely under the point at which the cut is to be made to prevent cutting or nicking insulation.

11. Slide inner ferrule under the braid. The braid should cover approximately two-thirds of the ferrule taper. Remove the blue silicone coating from the end of the braid over ferrule by lightly scraping with a knife or wire brush.

CAUTION

When removing silicone coating, care should be taken not to damage the braided wire shielding.

12. Pull the lead assembly back through cable outlet plate until cleaned braid binds in the outlet well. Position the Bendix 11-7074 Ferrule Seating Tool (Figure 8-22) over the insulation and firmly seat the ferrule by tapping the seating tool with a hammer or by using an arbor press.

13. Measure 1/2 inch from tapered ferrule and strip remaining insulation from wire. (Refer to Figure 8-23.)

14. Insert Bendix 11-7073 Needle (Figure 8-24) through the small hole of the grommet and over the stripped end of the wire. (Refer to Figure 8-25.) Slide grommet down needle until it seats tightly against the tapered ferrule.

15. Cut the wire 3/8 inch from the top of the grommet outlet. (See Figure 8-26.) Double the wire over as shown in A of Figure 8-27. Slide the eyelet over the doubled wire until it is firmly seated in the recess of the grommet outlet.

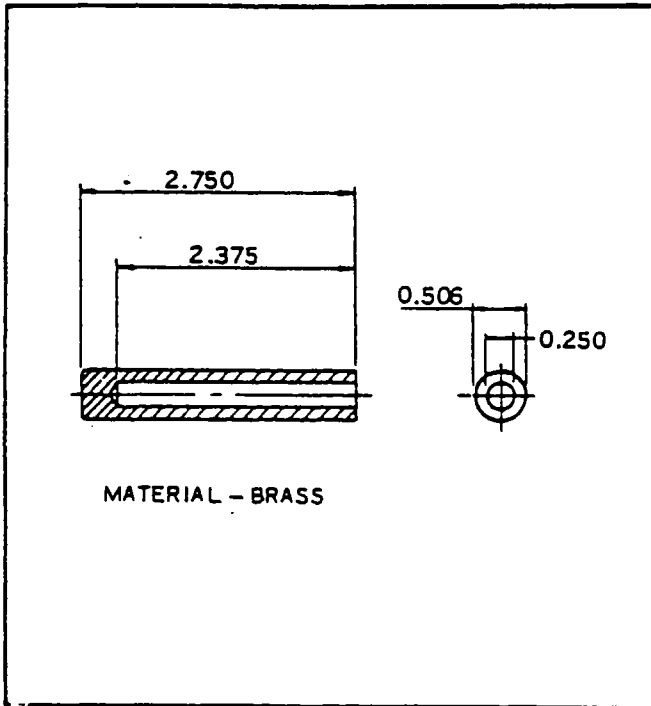

Figure 8-22. Ferrule Seating Tool

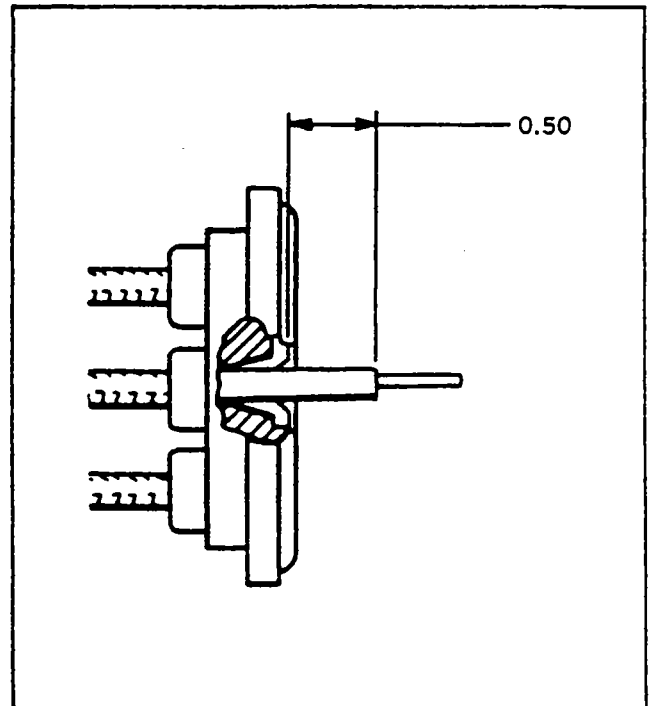

Figure 8-23. Measuring Wire From Top of Ferrule

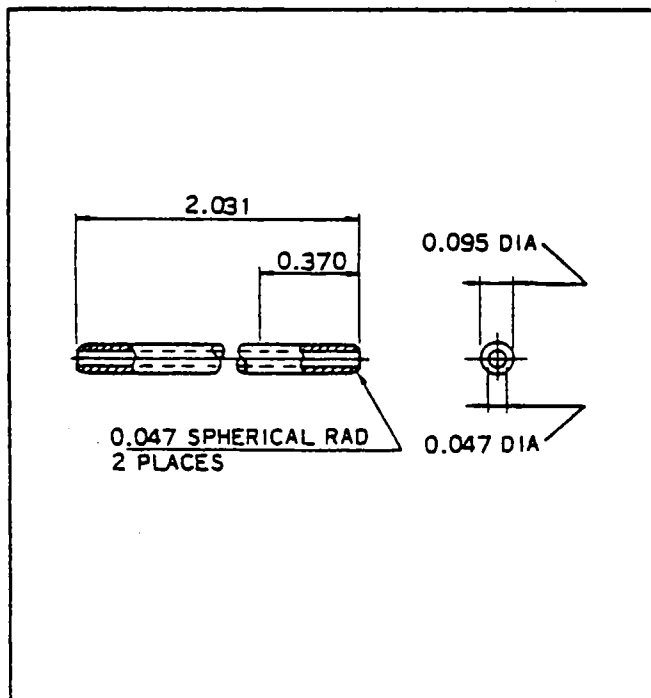

Figure 8-24. Needle

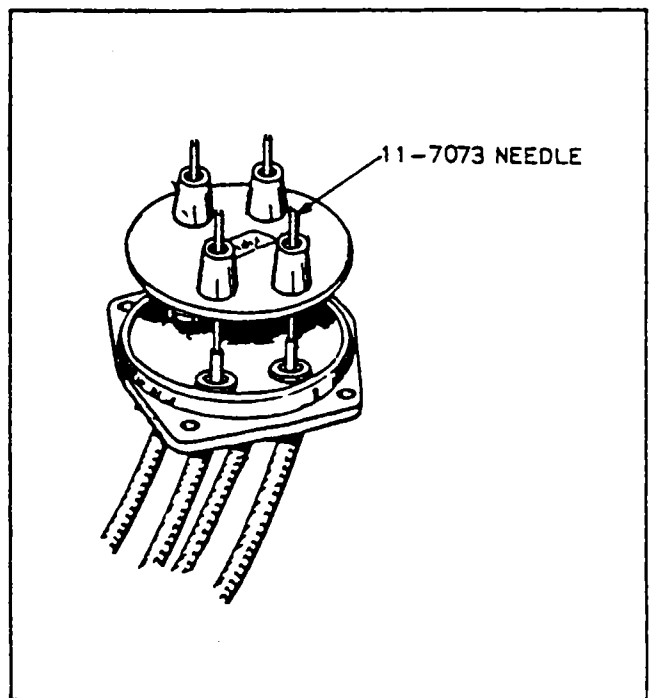

Figure 8-25. Installing Grommet Over Lead Assemblies

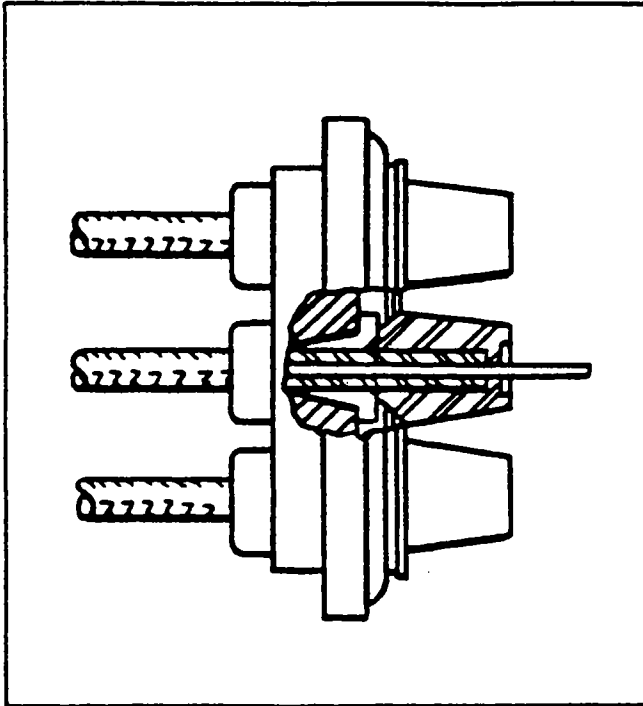

Figure 8-26. Lead Assembly Installed in Grommet

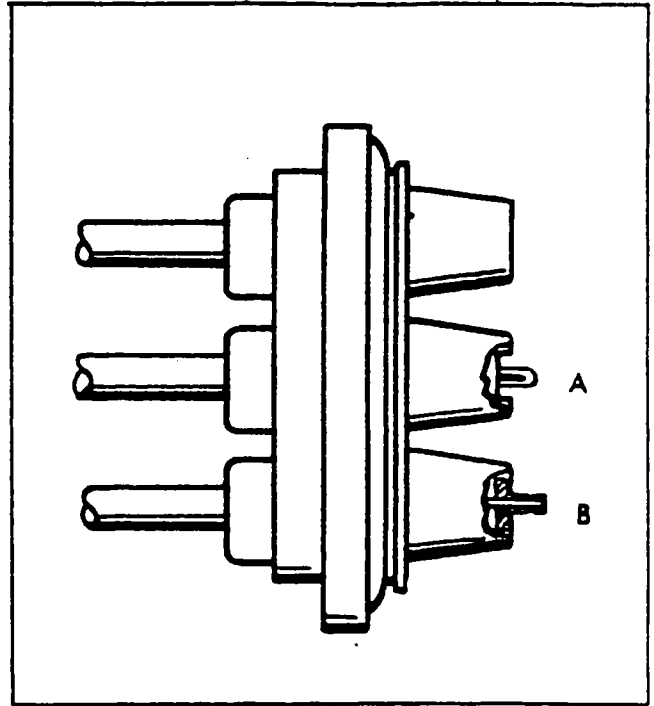

Figure 8-27. Wire Doubled Over For Installation of Eyelet

16. Using a suitable crimping tool or equivalent, crimp the eyelet to the wire. Approximately 1/32 inch of wire should extend from the end of the eyelet after crimping. See B of Figure 8-27.

NOTE

If the crimping tool is not available, a satisfactory connection can be made by soldering with Kester Flux 709 or equivalent and a non-corrosive solder. After soldering, clean solder joints using denatured alcohol.

17. Install the clamps and cable ties, as necessary, to secure the lead to the engine.

CAUTION

Leads should be dressed away from hot spots, such as manifolds and sharp edges which cause chafing.

PIPER SENECA II SERVICE MANUAL

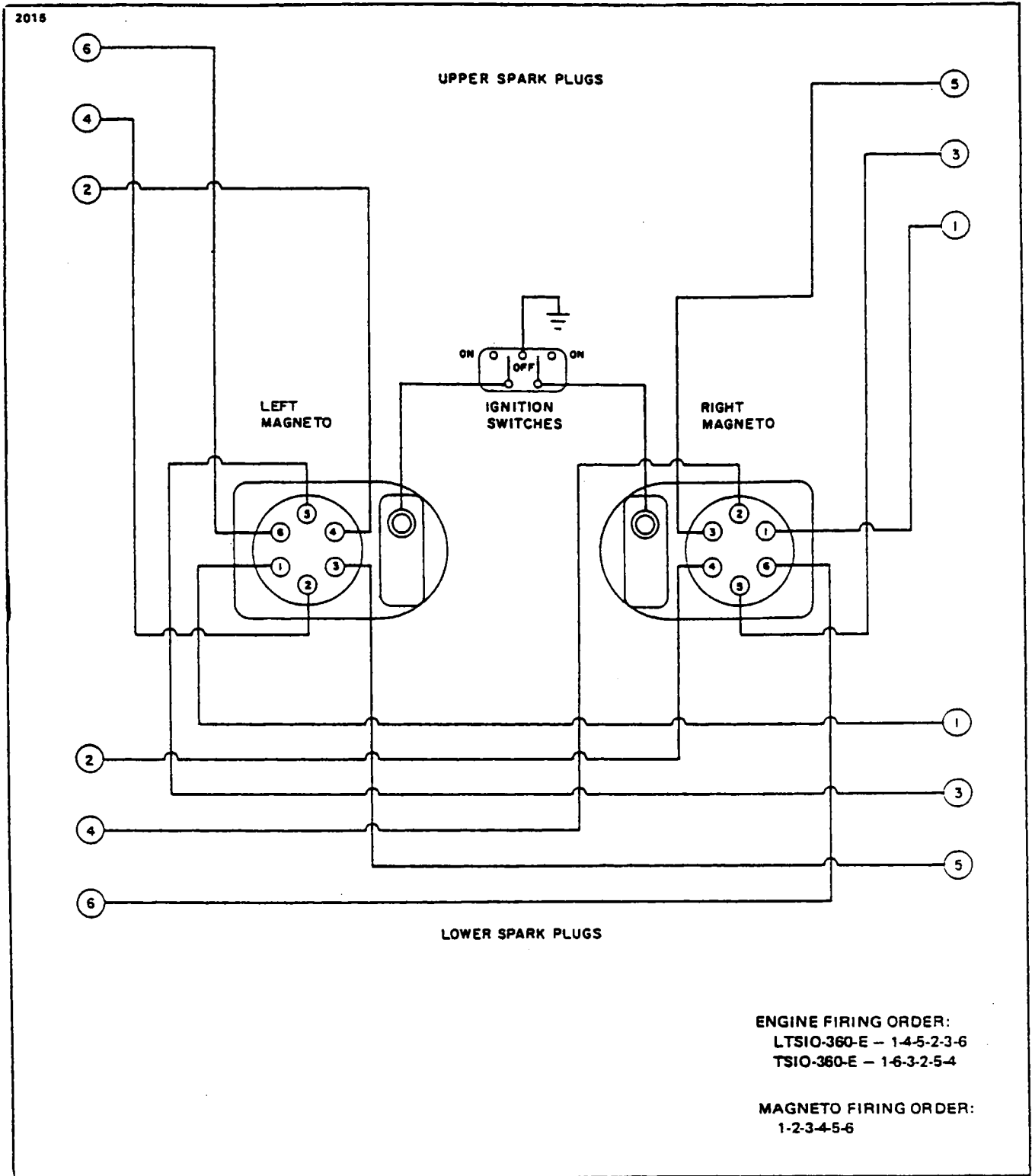

Figure 8-28. Ignition Schematic

2C1

INTENTIONALLY LEFT BLANK

8-43. INSTALLATION OF HARNESS. Before installing the harness plate on the magneto, check the mating surfaces for cleanliness. Spray the entire face of the grommet with a light coat of Plastic Mold Spray, SM-O-O-TH Silicone Spray or equivalent. This will prevent the harness grommet from sticking to the magneto distributor block.

- a. Place the harness terminal plate on the magneto and tighten the nuts around the plate alternately to seat the cover squarely on the magneto. Torque the nuts to 18 to 22 inch-pounds.
- b. Route the ignition wires to their respective cylinders as shown in Figure 8-28.
- c. Clamp the harness assembly in position.
- d. Connect the leads to the spark plugs.

8-44. SPARK PLUGS.

8-45. REMOVAL OF SPARK PLUGS.

- a. Loosen the coupling nut on the harness lead and remove the terminal insulator from the spark plug barrel well. (A crows foot adapter is needed to remove the lower spark plugs.)

NOTE

When withdrawing the ignition cable lead connection from the plug, care must be taken to pull the lead straight out and in line with the centerline of the plug barrel; otherwise, a side load will be applied which frequently results in damage to the barrel insulator and connector. If the lead cannot be removed easily in this manner, the resisting contact between the neoprene collar and the barrel insulator will be broken by a rotary twisting of the collar. Avoid undue distortion of the collar and possible side loading of the barrel insulator.

- b. Remove the spark plug from the engine. In the course of engine operation, carbon and other combustion products will be deposited on the end of the spark plug and will penetrate the lower threads to some degree. As a result, greater torque is frequently required for removing a plug than for its installation. Accordingly, the torque limitations given do not apply to plug removal, and sufficient torque must be used to unscrew the plug. The higher torque in removal is not as detrimental as in installation, since it cannot stretch the threaded section. It does, however, impose a shearing load on this section and may, if sufficiently severe, produce a failure in this location.

NOTE

Torque indicating handle should not be used for spark plug removal because of the greater torque requirement.

- c. Place spark plugs in a tray that will identify their position in the engine as soon as they are removed.

NOTE

Spark plugs should not be used if they have been dropped.

234

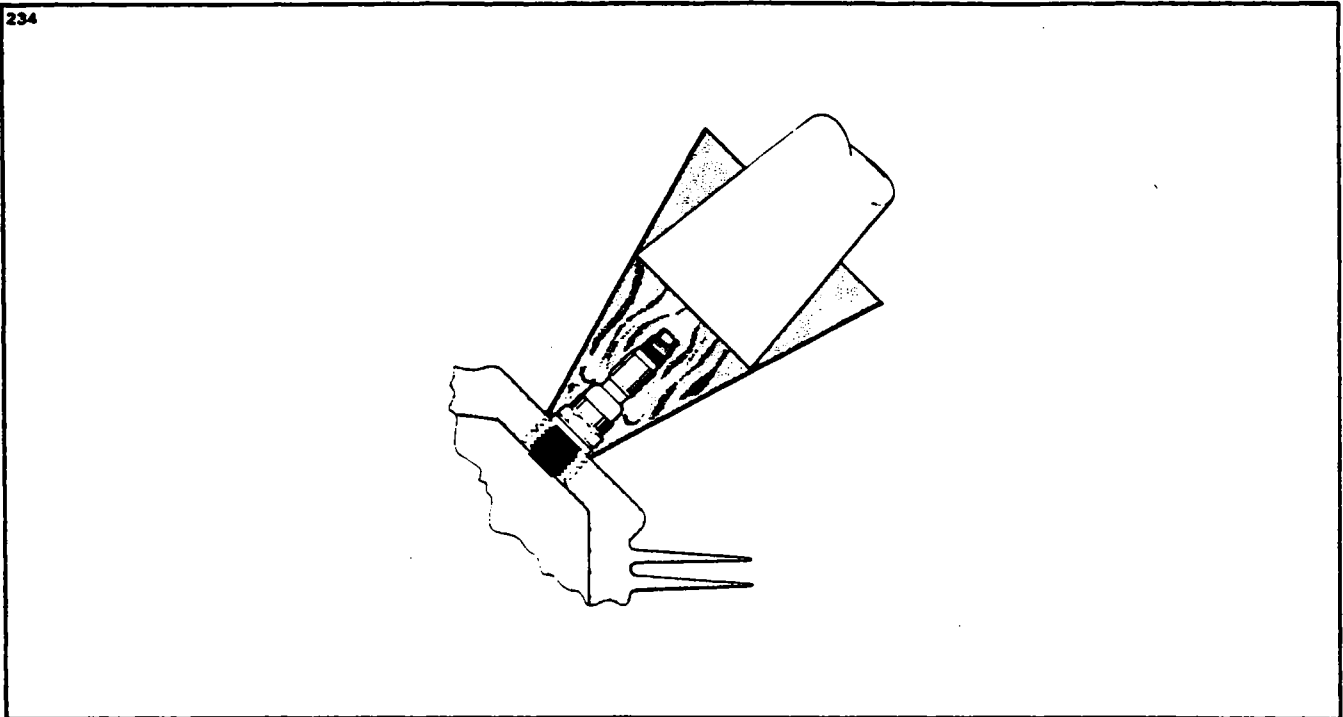

Figure 8-29. Removing Frozen Spark Plug

d. Removal of seized spark plugs in the cylinder may be accomplished by application of liquid carbon dioxide by a conical metal funnel adapter with a hole at the apex just large enough to accommodate the funnel of a CO2 bottle. (Refer to Figure 8-29.) When a seized spark plug cannot be removed by normal means, the funnel adapter is placed over and around the spark plug. Place the funnel of the CO2 bottle inside the funnel adapter and release the carbon dioxide to chill and contract the spark plug. Break the spark plug loose with a wrench. A warm cylinder head at the time the carbon dioxide is applied will aid in the removal of an excessively seized plug.

e. Do not allow foreign objects to enter the spark plug hole.

8-46. INSPECTION AND CLEANING OF SPARK PLUG.

- a. Visually inspect each spark plug for the following non-repairable defects:
 - 1. Severely damaged shell or shield threads nicked up, stripped or cross-threaded.
 - 2. Badly battered or rounded shell hexagons.
 - 3. Out-of-round or damaged shielding barrel.
 - 4. Chipped, cracked or broken ceramic insulator portions.
 - 5. Badly eroded electrodes worn to approximately 50% of original size.
- b. Clean the spark plug as required, removing carbon and foreign deposits.
- c. Set the electrode gap per the latest revision of Teledyne Continental Aircraft Engine Service Bulletin M77-10.
- d. Test the spark plug both electrically and for resistance.

THIS PAGE INTENTIONALLY LEFT BLANK

8-47. **INSTALLATION OF SPARK PLUGS.** Before installing spark plugs, ascertain that the threads within the cylinder are clean and not damaged.

a. Apply anti-seize compound sparingly on the threads and install gasket and spark plugs. Torque 360 to 420 inch-pounds.

CAUTION

Make certain the deep socket is properly seated on the spark plug hexagon as damage to the plug could result if the wrench is cocked to one side when pressure is applied.

b. Carefully insert the terminal insulator in the spark plug and tighten the coupling unit.

8-48. **LUBRICATION SYSTEM.**

8-49. **DESCRIPTION.** The oil system is a wet sump, force feed system with a capacity of 8 quarts. A conventional dipstick is provided for determining the oil quantity.

When the engine is running, oil is drawn through a screen and pick up tube which extends from the sump to a port in the crankcase. Oil then flows to the inlet of the gear type, engine driven oil pump and is forced under pressure through the pump outlet. A pressure relief valve prevents excessive oil pressure by allowing excess oil to be returned to the sump. After leaving the pump, the oil under pressure enters a full flow filter and is passed onto the oil cooler. If the filter element becomes blocked, a bypass relief valve will open to permit unfiltered oil to flow to the engine. An oil temperature control unit allows oil to bypass the oil cooler when the oil is cold. Some oil flows through the cooler to prevent congealing in cold weather. When the oil temperature reaches approximately 170° F, the oil temperature control unit actuates to close off the cooler bypass forcing the oil to flow through the cooler.

From the oil cooler oil enters the crankcase where it is directed to the bearing surfaces and other engine components requiring lubrication and cooling. The propeller governor boost engine oil pressure for operation of the propeller. A tap in the side of the crankcase supplies oil pressure for lubrication of the turbocharger bearings. Oil is carried to the turbocharger through an external line. After lubricating the turbocharger bearings it is drawn into a scavenge pump and forced back to the oil sump. Oil within the engine drains, by gravity, back into the sump.

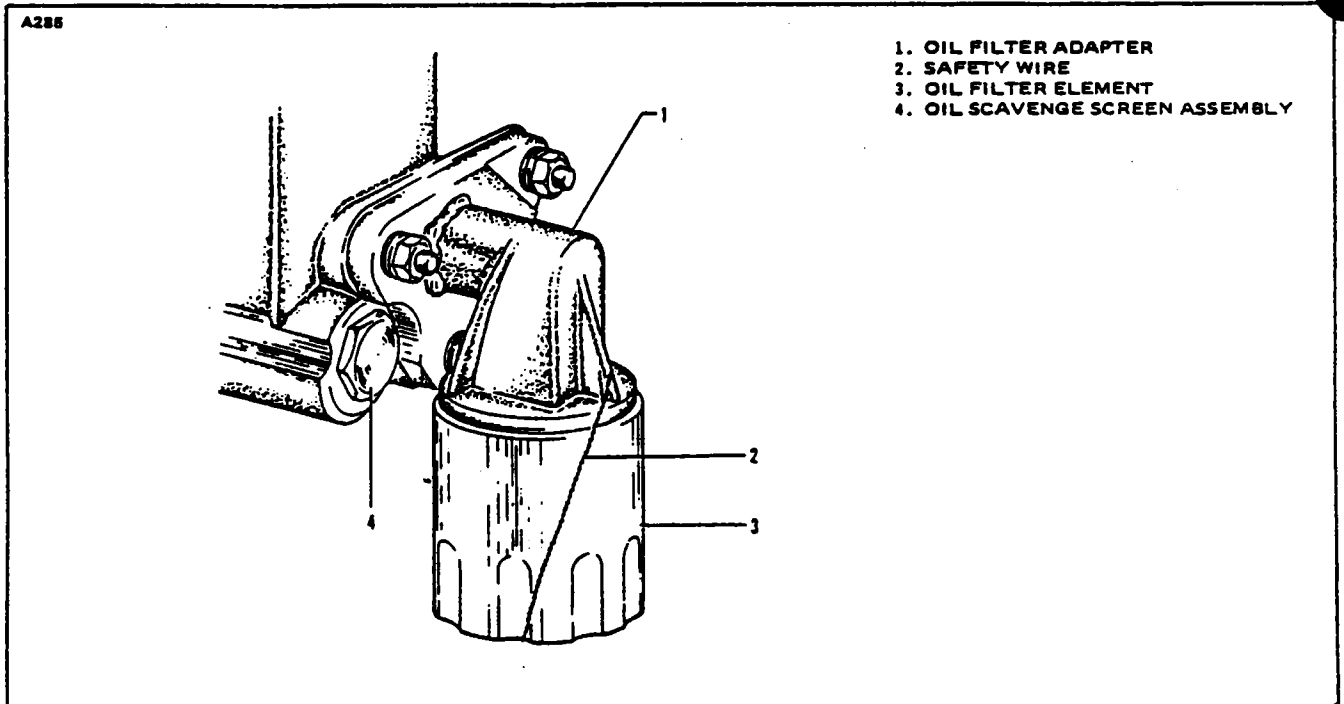

Figure 8-30. Lubrication System Maintenance Points

8-50. OIL FILTER REPLACEMENT. (Refer to Figure 8-30.) The oil filter element should be replaced after each 50 hours of engine operation. The filter element is mounted on the lower portion of the engine accessory case. Replace the filter element as follows:

- a. Remove the lockwire between the nut on the filter and the oil filter adapter and unscrew the filter element.
- b. Before installing a new filter, lubricate the gasket on the filter with engine oil.
- c. Torque the filter 18 to 20 foot-pounds or 3/4 to 1 full turn after the gasket makes contact.

CAUTION

Do not over torque.

- d. Run the engine and check for oil leaks; then install lockwire between nut on filter and adapter.

8-51. ENGINE FUEL SYSTEM.

8-52. DESCRIPTION. The fuel injection system is a multi-nozzle, continuous flow, altitude compensating system that regulates fuel flow to match engine operating conditions. The system consists of an engine driven fuel pump, a throttle body, a fuel manifold valve and fuel discharge nozzles.

The engine driven fuel pump is a positive displacement, rotary vane type pump with an integral vapor separator and altitude compensating aneroid valve.

The throttle body consists of a rotary valve metering unit attached to an air throttle that controls the flow of air to the engine. The position of the cam shaped edge of the rotary valve across the fuel delivery port and engine driven pump controls the fuel flow to the manifold valve and nozzles, thus controlling the fuel-air ratio.

The fuel manifold valve is the central point for dividing fuel to the individual cylinders. A diaphragm and plunger valve within the manifold valve raises or lowers by fuel pressure to open or close the individual fuel supply ports simultaneously.

The fuel discharge nozzles are an air bleed type nozzle with a calibrated orifice. A nozzle is installed in the cylinder head outside each intake valve for each cylinder.

8-53. FUEL INJECTION SYSTEM MAINTENANCE.

- a. Check all attaching parts for tightness.
- b. Check all fuel lines for leaks, evidence of damage, or chafing by metal to metal contact.
- c. Check control connections, levers, and linkages for safety.
- d. Inspect nozzles for cleanliness with particular attention to air screens and orifices. Use a standard 1/2 inch spark plug type deep socket to remove nozzles. Do not remove shield to clean air screens. Do not use wire or other object to clean orifices. To clean nozzles, remove from engine and immerse in fresh cleaning solvent. Use compressed air to dry.
- e. Unscrew strainer plug from fuel injection control valve and clean screen in solvent. Reinstall, safety, and check for leaks.
- f. During periodic lubrication, add a drop of engine grade oil on each end of the air throttle shaft and at each end of the linkage between the air throttle and fuel metering valve.

NOTE

Do not use any form of thread compound on fuel line fittings. Use only a fuel soluble lubricant such as engine oil.

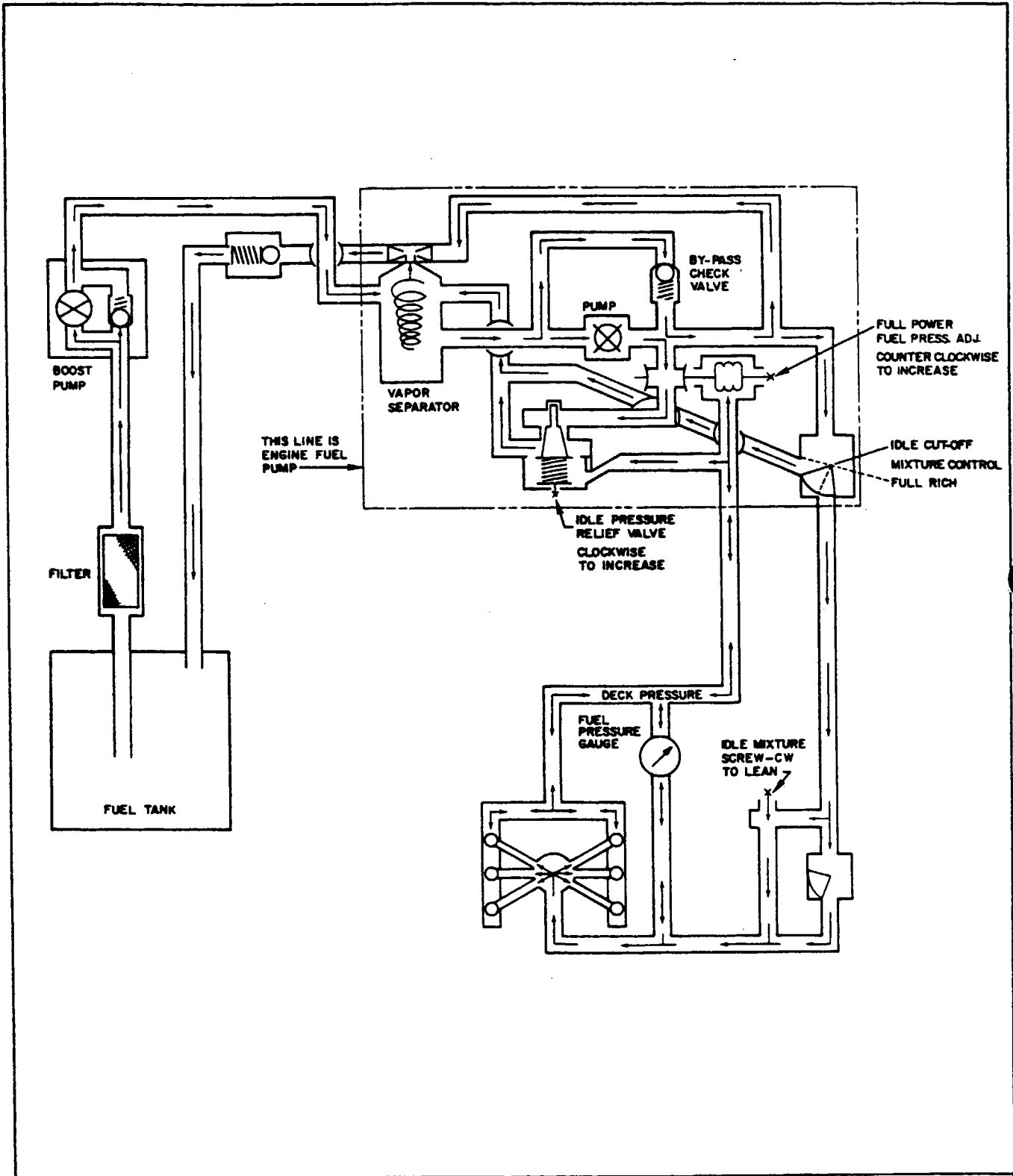

Figure 8-31. Schematic Diagram of Fuel Injection System

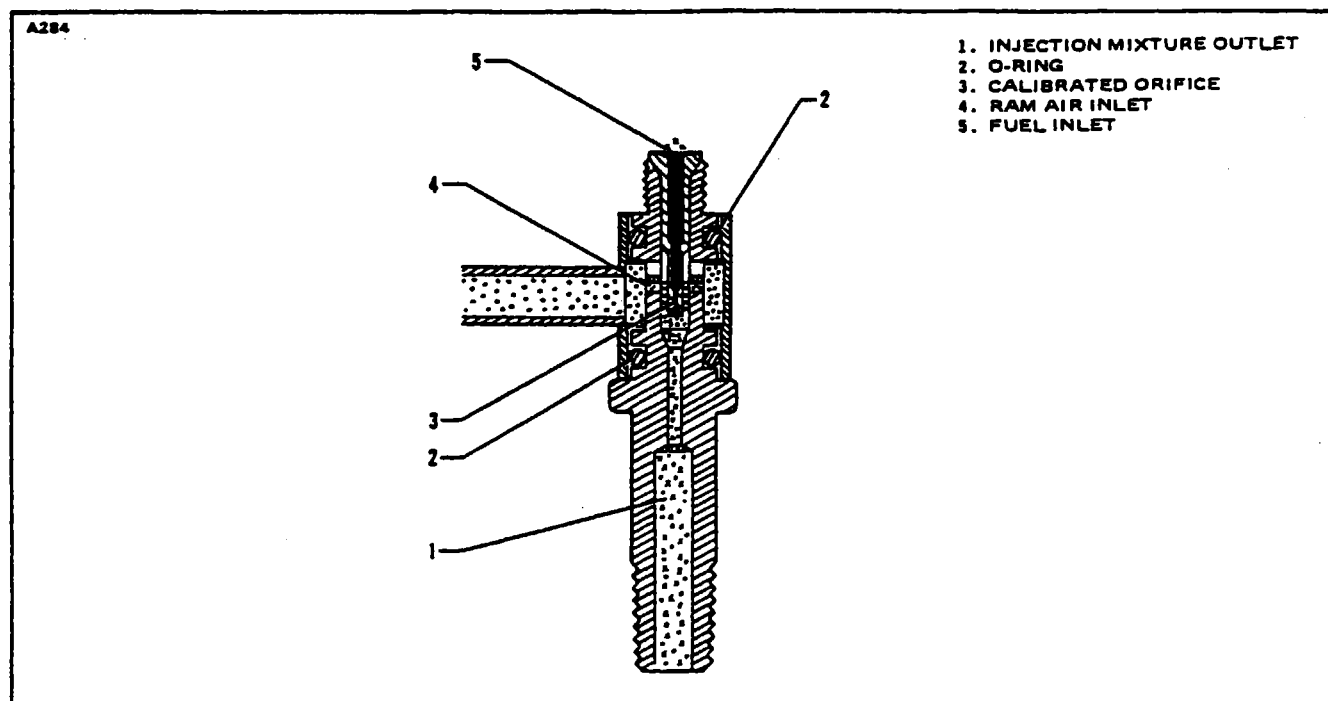

Figure 8-32. Fuel Injector Nozzle Assembly

8-54. FUEL INJECTOR NOZZLE ASSEMBLY.

8-55. REMOVAL OF FUEL INJECTOR NOZZLES.

- a. Remove the cowling side access panels.
- b. Disconnect the fuel line and remove the ram air line from the nozzle.
- c. Use a standard 1/2 inch spark plug type deep socket to remove the nozzle.

8-56. CLEANING AND INSPECTION OF FUEL INJECTOR NOZZLES.

- a. To clean the nozzles immerse in fresh cleaning solvent, use compressed air to dry.

CAUTION

Do not use wire or other objects to clean orifices.

- b. Inspect the nozzles for cleanliness; pay particular attention to the orifices. Check the condition of the nozzle and cylinder threads.

8-57. INSTALLATION OF FUEL INJECTOR NOZZLES.

- a. Carefully start the nozzles by hand to prevent cross-threading. Torque nozzle to 60 inch-pounds.
- b. Connect the fuel line to the nozzle.
- c. Reinstall cowling side panels.

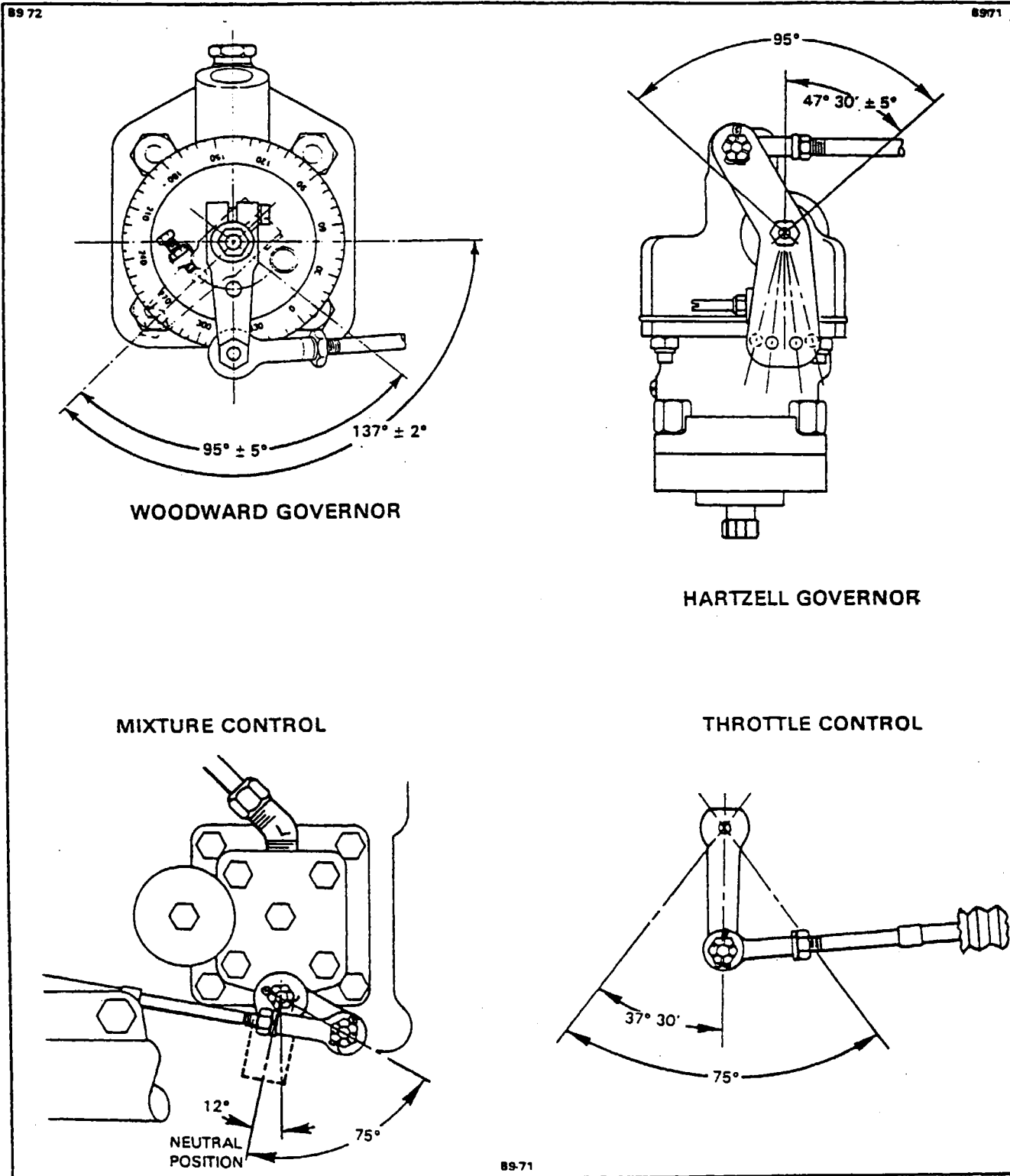

Figure 8-33. Engine Controls

8-58. ENGINE AND PROPELLER CONTROLS.

8-59. RIGGING THROTTLE, MIXTURE AND GOVERNOR CONTROLS. (Refer to Figure 8-33.)

- a. Rig the throttle control as follows:
 1. Place the quadrant throttle lever full forward.
 2. With the control arm on the fuel-air control unit in the full throttle position, rig the throttle quadrant lever to provide a minimum of .032 inches clearance from the forward stop. With the control arm at the idle stop, the quadrant throttle lever must have a minimum clearance of .032 inches from the aft stop.

NOTE

Both throttle controls must be within .25 of an inch in alignment in the aft position and within 1/2 a knob width in the full forward position.

- b. Rig the propeller control as follows:
 1. Place the propeller control lever full forward.
 2. With the propeller governor control arm in the low pitch (high RPM) position, rig the quadrant control lever to provide .047/.032 inches clearance from the forward stop.
- c. Rig the mixture control as follows:
 1. Place the mixture control lever full forward.
 2. With the mixture control arm on the engine fuel pump in the full rich position, rig the quadrant mixture lever to provide a minimum of .032 inches clearance from the forward stop.
 3. With the mixture control arm at idle cut-off, the quadrant mixture lever must have a minimum of .032 inches clearance from the aft stop.

NOTE

Both the mixture and propeller controls must be within .25 of an inch in alignment in the full forward position and within 1/2 a knob width in the full aft position.

PIPER SENECA II SERVICE MANUAL

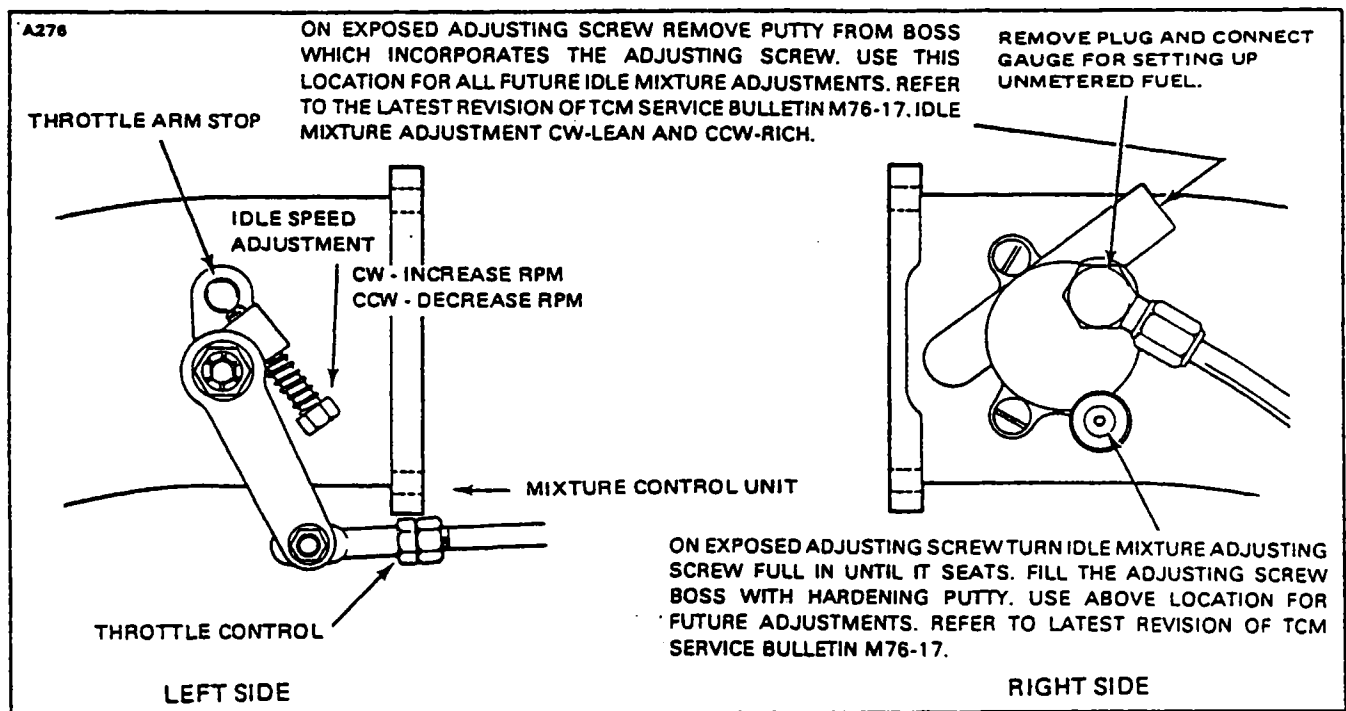

Figure 8-34. Idle Speed and Mixture Adjustment Points

8-60. ENGINE SETUP PROCEDURES. PP5500240 The following procedures should be used to check and adjust the power plants to maintain the required operating limits and insure obtaining good setup results. It is important that the following leak check be made before proceeding with any actual system adjustments:

a. Leak Check - Gauge Lines:

1. Disconnect manifold pressure line at air throttle body, compressor discharge pressure line at manifold valve and fuel pressure line at manifold valve.
2. Connect surgical tubing to the compressor discharge pressure line and evacuate the line until a 10 gallon per hour (maximum) positive indication on the fuel flow gauge is obtained. Clamp off the tubing and observe the gauge for a steady reading. Any change of this reading would indicate a leak in the system, which must be repaired prior to continuing with the setup procedures.

NOTE

A static system test unit can be used to leak check these lines.

3. Check the fuel pressure and manifold pressure lines in the same manner as given in Step 2, except apply positive pressure to the lines. Do not exceed 4 pounds per square inch (psi) on the fuel pressure gauge, or 4 inches of mercury (In. Hg) increase on the manifold pressure gauge.
4. Reconnect and tighten the manifold pressure, compressor discharge pressure and fuel pressure lines.
5. The difference in the static reading on the manifold pressure gauges should not exceed 1/2 in. Hg.
6. To reduce the possibility of trapped air in the fuel pressure lines, disconnect the fuel pressure line at the rear of the fuel flow gauge and activate the auxiliary fuel pump long enough to purge the lines; then reconnect the lines.

b. Exhaust Bypass Check: Ascertain that the exhaust bypass adjusting screw has from eight to nine threads showing below the jam nut. This screw is preset at the factory and should not require any adjustment, unless it is known that critical altitude is not correct; in this case, use procedure given in Step k. (Refer to Figure 8-36.)

c. Idle Performance Check:

NOTE

It is extremely important that both engines are thoroughly warmed up, operated and adjusted together to keep them matched. However, excessive engine temperatures must be avoided since setup temperature must closely parallel temperatures in flight.

1. Remove the cap from the tee fitting on the right side of the throttle body. (Refer to Figure 8-34.)
2. Install a 0-60 psig calibrated pressure gauge (vented to the atmosphere) to the tee, using a suitable length of flexible tube. The gauge should always be at the same level as the fuel manifold valve when checking fuel pressure.
3. Purge the air from the tube.

CAUTION

During all engine operations outlined in these instructions, exercise CAUTION to avoid harm or damage to personnel and equipment by propeller blast and rotating propeller blades. When required to make adjustments to the engine in close proximity to the propeller arc, shut the engine down before making adjustments.

d. Check and Adjustment of Idle Fuel Pressure:

NOTE

The following setup procedure is accomplished with the boost pumps OFF, the engines thoroughly warmed up and adjusted together to keep them matched.

1. Back off the idle speed adjusting screw two turns. (Refer to Figure 8-34.)
2. Start both engines and warm them up at 1,500 to 1,800 RPM until the oil pressures are in the green arc, cylinder head temperatures are in the lower one-quarter of the green arc, and the oil temperatures are 160° to 180°F.
3. While maintaining 700 ± 25 RPM, set the idle fuel pressure at 6.5 ± 0.25 psi by adjusting the idle pump adjustment screw (refer to Figure 8-35, item 6); clockwise adjustment increases pressure; counterclockwise adjustment decreases pressure.

e. Check and Adjustment of Idle Mixture: (Refer to Figure 8-34.)

1. Operate the engine at 1,500 to 1,800 RPM until cylinder head temperatures are in the lower one-quarter of the green arc, and the oil temperatures are 160° to 180° F.
2. Reduce the engine speed and stabilize it at 700 ± 25 RPM.
3. Slowly, but positively, move the mixture control from the full rich position to the idle.

The engine speed should increase 75 RPM minimum, 100 RPM maximum before beginning to drop toward zero. Move the mixture control back to full rich before the engine stops.

PIPER SENECA II SERVICE MANUAL

4. If the engine speed increase is less than 75 RPM, adjust the idle mixture adjustment to enrich the mixture (counterclockwise). If the engine speed increase is more than 100 RPM, adjust the idle mixture to lean the mixture (clockwise).
5. After each adjustment, increase RPM to 1500-1700 for 10 seconds to "clean the engine out".
6. Double check idle fuel pressure after adjusting idle mixture.

NOTE

Any adjustment of the idle fuel pressure or idle mixture will probably change the other reading. Continue to adjust and cross-check until both are correct.

f. Check and Adjustment of Idle Speed: (Refer to Figure 8-34.)

1. With the idle fuel pressure and idle mixture set in accordance with instructions given in Steps "d" and "e," cylinder head temperatures in the lower one-quarter of the green arc, and oil temperatures at 160° to 180°F, set engine speed at 700 ± 25 RPM.
2. Adjust the idle speed adjusting screw until contact is made with the throttle arm stop.

NOTE

After final adjustment, recheck the idle fuel pressure, idle mixture and idle speed to ascertain that all are within specifications given in previous steps.

g. Check and Adjustment for Full Power Performance: (Refer to Figure 8-35.)

CAUTION

Before attempting full power checks, be sure that the brakes are properly maintained and set, and that the ground conditions will not permit the wheels to slip during full power check.

NOTE

Fuel flows are given for sea level density altitude. Use Chart VIII-IV to interpolate correct fuel flow for the actual engine RPM.

1. Run both engines at 39.8 to 40.0 in. Hg. manifold pressure (overboost lights activated), and beat synchronize the engines at 2,500 to 2,575 RPM using the propeller governor controls. Readjust the throttle controls as required to maintain 39.8 to 40.0 in. Hg. manifold pressure on both engines.
2. Fuel flow should be 21.5 to 22.0 gallons per hour (gph), for each engine with the mixture controls in the full rich position. Within this range, the readings shall match.
3. Observe the 0-60 calibrated gauge to cross check performance. High unmetered pressure should be 42-45 psi.
4. If adjustment is required, shut the engine down, loosen the jam nut on the adjusting screw located on the aneroid housing of the fuel pump. (Refer to Figure 8-35, item 2.) Clockwise adjustment decreases fuel flow reading; counterclockwise adjustment increases fuel flow reading; one full turn will cause a 1.0 to 1.5 gph change. Use CAUTION when loosening and tightening the jam nut so as not to change settings.

PIPER SENECA II SERVICE MANUAL

NOTE

If other than minor adjustments are required to the fuel flow, a complete investigation of interface systems is required.

5. Restart the engines and recheck the high end fuel flow.
6. Recheck the idle settings per instructions c, d, e and f, and adjust as required.
7. Recheck Full Power Fuel Flow settings per instruction g, and adjust system as required.
8. With engines operating at 2575 RPM (39.8 to 40 in. Hg manifold pressure), lean the mixture to obtain 21 gph fuel flow readings. The unmetered fuel pressure on the calibrated pressure gauge should be 37 to 40 psi.

h. Checking Fuel System Match:

1. Set propeller governors to maintain 1900 to 2000 RPM and open throttles slowly, increasing engine speed until reaching 40 in. Hg manifold pressure. Keep engine speeds beat synchronized.
2. Slowly reduce manifold pressures, keeping needles matched and observe fuel flows. A properly adjusted system will track fuel flows within a needles width of each other.

NOTE

The key to keeping engines and fuel systems matched is beat synchronizing of both engines and operating them together to keep temperatures equal. Adjusting engines singly seldom produces a good match.

- i. Remove test equipment; safety wire the exhaust bypass screw and check nut to the bypass screw housing; reinstall the cap on the tee of the throttle body housing.
- j. The accuracy of the cockpit fuel flow gauge at maximum power can be checked against a calibrated gauge by connecting the calibrated gauge at the manifold valve and maintaining the gauge on the same level as the valve while checking pressures and using Chart VIII-V.

NOTE

The calibrated gauge fuel line must be purged of air, and the reference side of the calibrated gauge vented to turbo discharge pressure.

- k. Flight Test: A complete flight test should be made for final adjustments of fuel flow and bypass valve. The following steps should be followed:
 1. At 8,000 feet density altitude, set the engines to operate at $2,450 \pm 25$ RPM and 31.0 to 32.0 in. Hg manifold pressure.
 2. Lean each engine to 25°F rich of peak exhaust gas temperature (EGT). (Peak EGT may not be the same for both engines; however, the difference should not exceed 50°F .)
 3. Fuel flow at these conditions should be 11.0 to 12.0 gph.
 4. Place the aircraft in a climb altitude with full rich mixture, cowl flaps open, full throttle (2575 \pm 25 RPM). Manifold pressure 39.8-40.0 in. Hg (overboost annunciator lights illuminated) and airspeed 105 mph.
 5. Continue to climb until overboost annunciator lights go out (indicating critical altitude). As the lights go out note fuel flow, indicated altitude and OAT.
 6. Fuel flow at critical altitude should be 23.0-25.0 GPH and density altitude 11,500 minimum to 12,500 maximum.

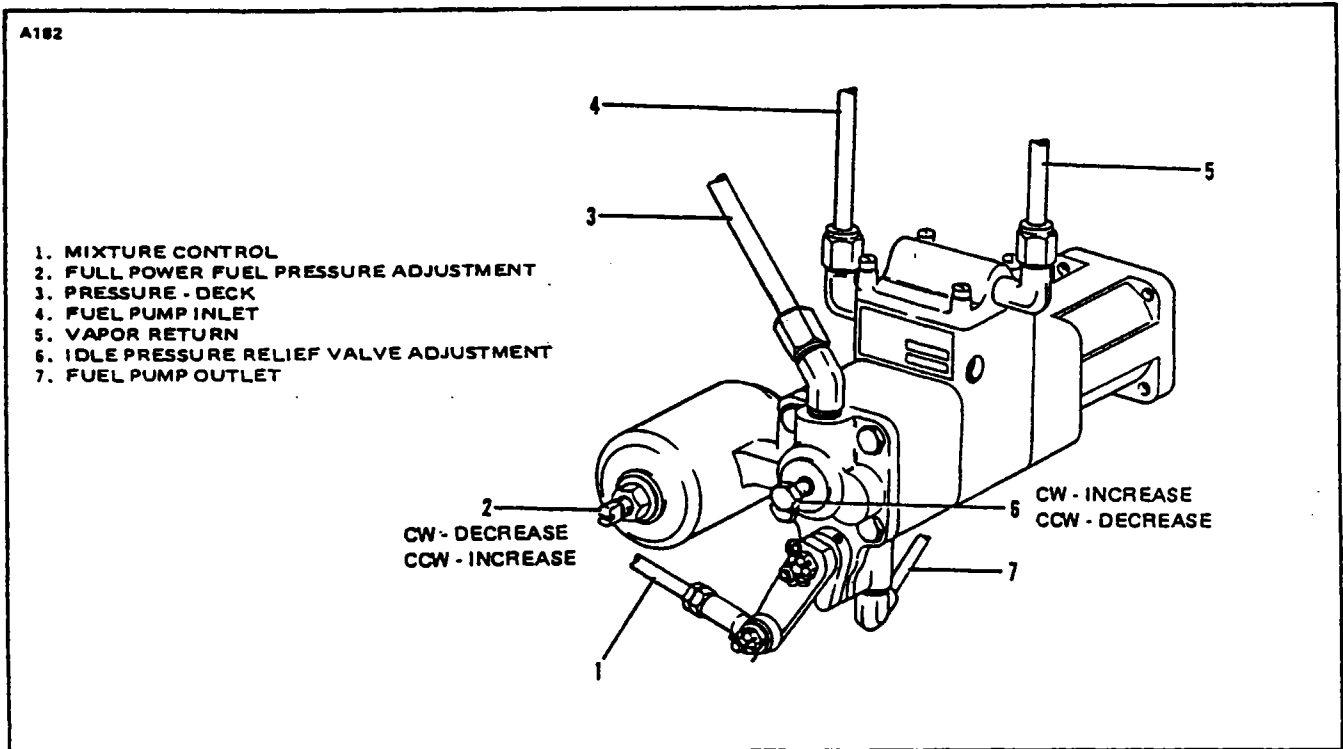

Figure 8-35. Sectional View of Altitude Compensating Fuel Pump Assembly

7. If a discrepancy in critical altitude was noted, adjust the exhaust bypass valve. (Turning the exhaust bypass valve screw one full turn will alter the critical altitude approximately 1,000 feet.) Adjustments of critical altitude in excess of 500 feet may require retrimming of the fuel flows at 100% power.

8. With full rich mixture, cowl flaps open, $2,575 \pm 25$ RPM, 105 MPH airspeed, and 1,000 to 3,000 feet density altitude, check the operation of the manifold pressure relief valve. Slowly advance one throttle to the wide open position. The manifold pressure shall stabilize between 42.0 and 44.0 in. Hg; there shall be no loss of power, and the fuel flow indication shall be well over the red line. Do not exceed 40.0 in. Hg manifold pressure for more than ten seconds. Repeat this check on the other engine.

NOTE

Idle speed and idle mixture indication is a function of engine temperatures. Therefore, at normal ground idle temperatures (cylinder and oil temperature indications may or may not be "in the green") idle speed will be approximately 700 RPM, and the idle mixture check will result in a 25 to 50 RPM increase in engine speed.

PIPER SENECA II SERVICE MANUAL

2013

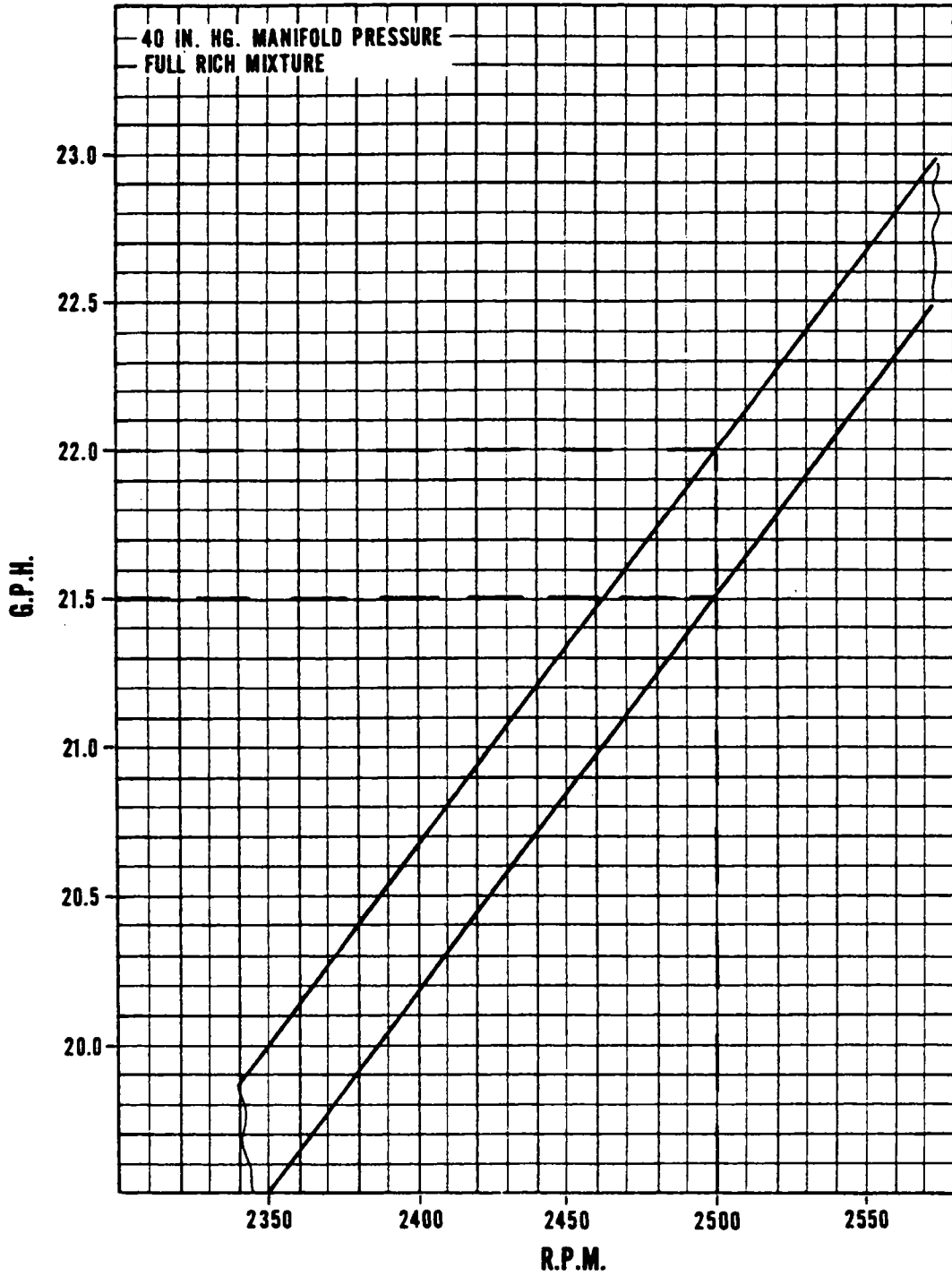

TABLE VIII-IV FUEL FLOW VS. ENGINE SPEED

Reissued: 10/11/79

POWER PLANT

2C17

Island Enterprises

PIPER SENECA II SERVICE MANUAL

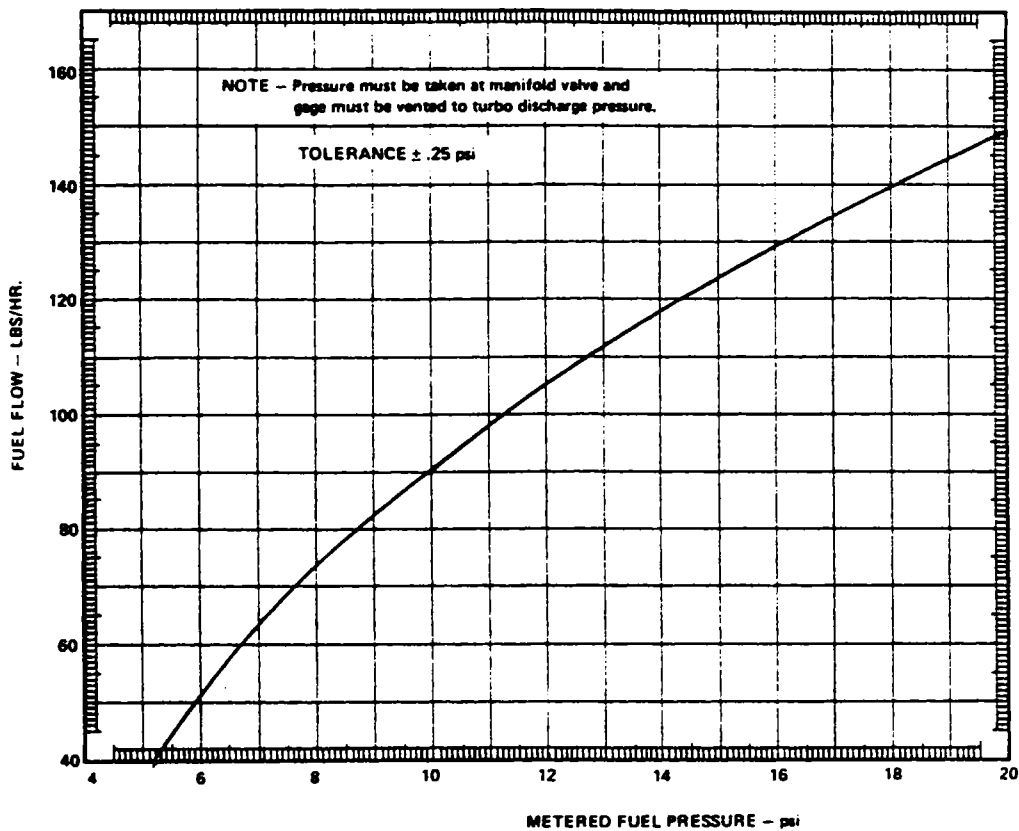

TABLE VIII-V METERED FUEL ASSEMBLY CALIBRATION

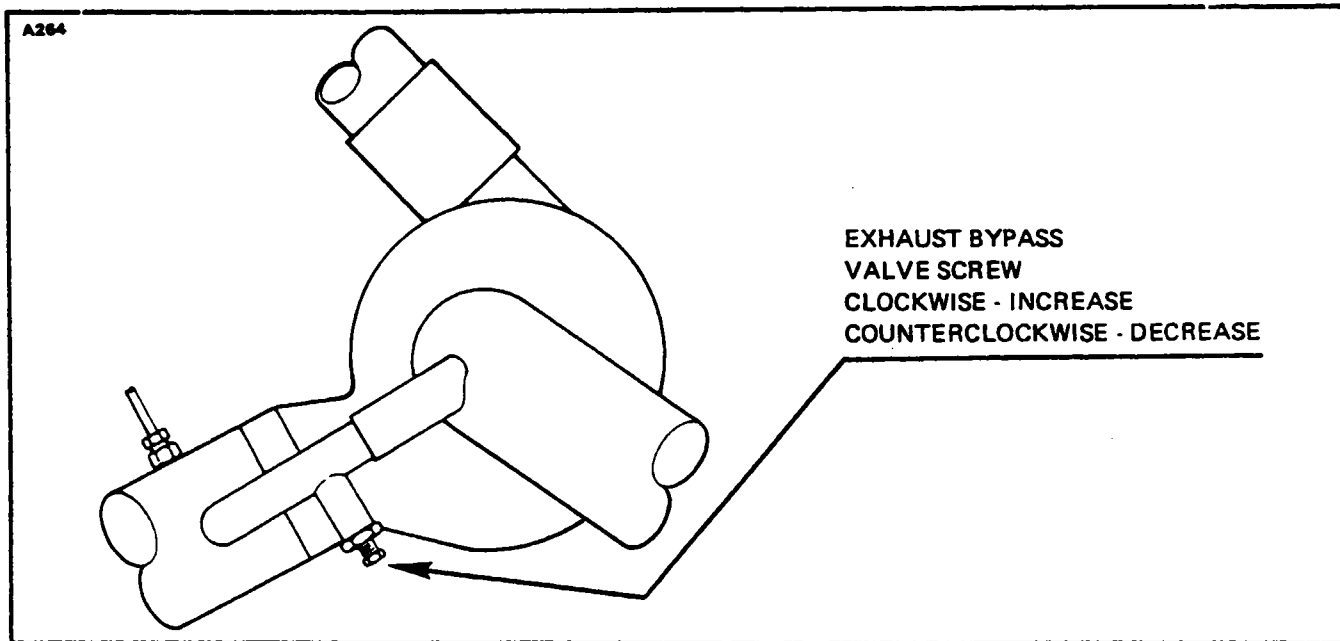

Figure 8-36. Exhaust Bypass Valve Screw

PIPER SENECA II SERVICE MANUAL

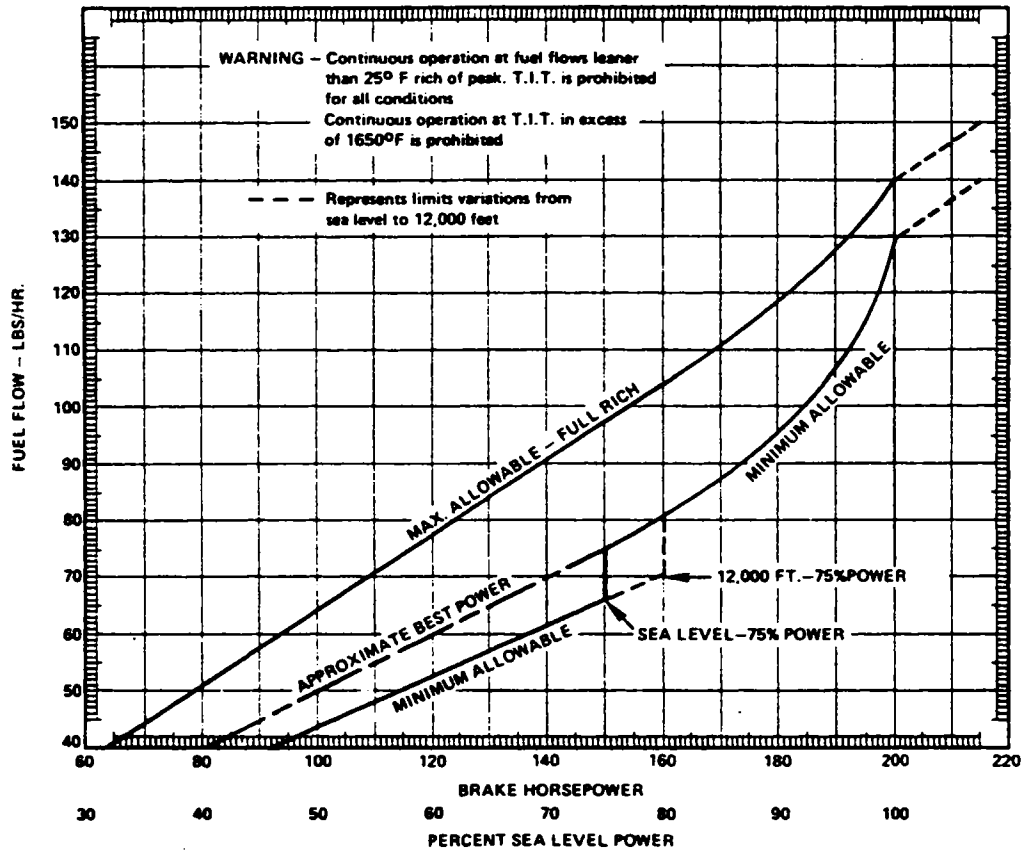

TABLE VIII-VI LIMITS - FUEL FLOW VS. BRAKE H.P.

Reissued: 10/11/79

POWER PLANT

2C19

PIPER SENECA II SERVICE MANUAL

TABLE VIII-VII TROUBLESHOOTING CHART (ENGINE)

Trouble	Cause	Remedy
<p>Engine will not start.</p>	<p>No fuel gauge pressure - no fuel to engine.</p> <p>Have gauge pressure - engine flooded.</p> <p>Have gauge pressure - no fuel to engine.</p>	<p>Check fuel control for proper position, auxiliary pump "ON" and operating, feed valves open. Fuel filters open and tank fuel level.</p> <p>Turn off auxiliary pump and ignition switch; set throttle to "FULL OPEN" and fuel control to "IDLE CUTOFF," and crank engine to clear cylinders of excess fuel. Repeat starting procedure.</p> <p>Check for bent or loose fuel lines. Loosen line at fuel nozzle. If no fuel shows, replace fuel manifold valve.</p>
<p>Engine starts but fails to keep running.</p>	<p>Inadequate fuel to fuel manifold valve.</p> <p>Defective ignition system.</p>	<p>Set fuel control in "FULL RICH" position; turn auxiliary pump "ON," check to be sure feed lines and filters are not restricted. Clean or replace defective components.</p> <p>Check accessible ignition cables and connections. Tighten loose connections. Replace defective spark plugs.</p>
<p>Engine runs rough at idle.</p>	<p>Improper idle mixture adjustment.</p> <p>Fouled spark plugs.</p> <p>Discharge nozzle air vent manifold restricted or defective.</p>	<p>Readjust idle setting. Turn adjustment screw clockwise to lean mixture and counterclockwise to richen mixture.</p> <p>Remove and clean plugs, adjust gaps. Replace defective plugs.</p> <p>Check for bent or loose connections. Tighten loose connections. Check for restrictions and replace defective components.</p>
<p>CONTINUED ON NEXT PAGE</p>		

PIPER SENECA II SERVICE MANUAL

TABLE VIII-VII TROUBLESHOOTING CHART (ENGINE) (cont.)

Trouble	Cause	Remedy
<p>Engine has poor acceleration.</p>	<p>Idle mixture too lean.</p> <p>Incorrect fuel-air mixture, worn control linkage or restricted air cleaner.</p> <p>Defective ignition system.</p> <p>Malfunctioning turbocharger.</p>	<p>Readjust idle mixture.</p> <p>Tighten loose connections. Service air cleaner.</p> <p>Check accessible cables and connections. Replace defective spark plugs.</p> <p>Check operation; listen for unusual noise. Check waste gate valve and for exhaust system defects. Tighten loose connections.</p>
<p>Engine runs rough at speeds above idle.</p>	<p>Improper fuel-air mixture.</p> <p>Restricted fuel nozzle.</p> <p>Ignition system and spark plugs defective.</p>	<p>Check manifold connections for leaks. Tighten loose connections. Check fuel control for setting and adjustment. Check fuel filters and screens for dirt. Check for proper pump pressure and readjust as necessary.</p> <p>Remove and clean all nozzles.</p> <p>Clean and regap spark plugs. Check ignition cables for defects. Replace defective components.</p>
<p>Engine lacks power, reduction in maximum manifold pressure or critical altitude.</p>	<p>Incorrectly adjusted throttle control, "sticky" linkage or dirty air cleaner.</p> <p>Improperly adjusted waste gate valve.</p>	<p>Check movement of linkage by moving control from idle to full throttle. Make proper adjustments and replace worn components. Service air cleaner.</p> <p>Check waste gate adjustment. (Refer to Paragraph 8-61.)</p>
<p>CONTINUED ON NEXT PAGE</p>		

PIPER SENECA II SERVICE MANUAL

TABLE VIII-VII TROUBLESHOOTING CHART (ENGINE) (cont.)

Trouble	Cause	Remedy
<p>Engine lacks power, reduction in maximum manifold pressure or critical altitude. (cont.)</p>	<p>Defective ignition system.</p>	<p>Inspect spark plugs for fouled electrodes heavy carbon deposits, erosion of electrodes, improperly adjusted electrode gaps and cracked porcelains. Test plugs for regular firing under pressure. Replace damaged or misfiring plugs. Refer to the latest revision of Teledyne Continental Aircraft Engine Service Bulletin M77-10 for correct spark plug gap.</p>
	<p>Loose or damaged exhaust system.</p>	<p>Inspect entire exhaust system to turbocharger for cracks and leaking connections. Tighten connections and replace damaged parts.</p>
	<p>Loose or damaged intake manifold.</p>	<p>Inspect entire manifold system for possible leakage at connections. Replace damaged components; tighten all connections and clamps.</p>
	<p>Fuel nozzles defective.</p>	<p>Inspect fuel nozzle vent manifold for leaking connection. Tighten and repair as required. Check for restricted nozzles and lines and clean or replace as necessary.</p>
	<p>Malfunctioning turbocharger.</p>	<p>Check for unusual noise in turbocharger. If malfunction is suspected, remove exhaust and/or air inlet connections and check rotor assembly for possible rubbing in housing, damaged rotor or defective bearings. Replace turbocharger if damage is noted.</p>
	<p>Exhaust system gas leakage.</p>	<p>Inspect exhaust system for gas leakage, gaskets at turbine inlet flanges, etc., and correct.</p>

CONTINUED ON NEXT PAGE

PIPER SENECA II SERVICE MANUAL

TABLE VIII-VII TROUBLESHOOTING CHART (ENGINE) (cont.)

Trouble	Cause	Remedy
<p>Low fuel pressure.</p>	<p>Restricted flow to fuel metering valve.</p> <p>Fuel nozzle vent system defective causing improper pressure regulation.</p> <p>Fuel control lever interference.</p> <p>Incorrect fuel injector pump adjustment and operation.</p> <p>Defective fuel injector pump relief valve.</p> <p>Air leakage in fuel pump pressurization line.</p>	<p>Check mixture control for full travel. Check for restrictions in fuel filters and lines; adjust control and clean filters. Replace damaged parts.</p> <p>Check venting system for leaks at connections and other defects. Tighten connections and replace defective parts.</p> <p>Check operation of throttle control and for possible contact with cooling shroud. Adjust as required to obtain correct operation.</p> <p>Check and adjust using appropriate equipment. Replace defective pump.</p> <p>Replace pump if cleaning and lapping valve does not correct problem.</p> <p>Locate cause of leakage and correct.</p>
<p>High fuel pressure.</p>	<p>Restricted flow beyond fuel control assembly.</p> <p>Defective relief valve operation in fuel injector.</p>	<p>Check for restricted fuel nozzles or fuel manifold valve. Clean or replace nozzles. Replace defective fuel manifold valve.</p> <p>Check fuel injector pump control line from turbo-charger for loose connections and defects. Tighten connections, replace damaged line.</p>

CONTINUED ON NEXT PAGE

PIPER SENECA II SERVICE MANUAL

TABLE VIII-VII TROUBLESHOOTING CHART (ENGINE) (cont.)

Trouble	Cause	Remedy
High fuel pressure. (cont.)	<p>Restricted re-circulation passage in fuel injector.</p> <p>Air leakage in fuel gauge vent pressurization line.</p>	<p>Replace pump.</p> <p>Locate cause of leakage and eliminate.</p>
Fluctuating fuel pressure.	<p>Vapor in fuel system.</p> <p>Fuel gauge line leak or improperly purged lines.</p>	<p>Normally operating the auxiliary pump will clear system. Operate auxiliary pump and purge system.</p> <p>Purge gauge line and tighten connections.</p>
Low oil pressure on engine gauge.	<p>Insufficient oil in oil sump, oil dilution or using improper grade oil for prevailing ambient temperature.</p> <p>High oil temperature.</p> <p>Leaking, damaged or loose oil line connections - Restricted screens and filter.</p>	<p>Add oil or change oil to proper viscosity.</p> <p>Defective vernatherm valve in oil cooler; oil cooler restriction. Replace valve or clean oil cooler.</p> <p>Check for restricted lines and loose connections, and for partially plugged oil filter and screens. Clean parts, tighten connections, and replace defective parts.</p>

CONTINUED ON NEXT PAGE

PIPER SENECA II SERVICE MANUAL

TABLE VIII-VII TROUBLESHOOTING CHART (ENGINE) (cont.)

Trouble	Cause	Remedy
Low oil pressure on engine gauge. (cont.)	Leaking oil seal in turbocharger. Defective check valve in turbocharger oil supply line.	Check for oil in turbocharger exhaust outlet. Replace turbocharger. Disassemble and clean valve or replace.
Poor engine idle cutoff.	Engine getting fuel.	Check fuel control for being in full "IDLE CUTOFF" position. Check auxiliary pump for being "OFF." Check for leaking fuel manifold valve. Replace defective components.
White smoke exhaust.	Turbo coking oil forced through seal in turbine housing.	Clean or change turbocharger.

2D2
INTENTIONALLY LEFT BLANK

2D3

INTENTIONALLY LEFT BLANK

SECTION IX

FUEL SYSTEM

Paragraph		Aerofiche Grid No.
9-1.	Introduction	2D6
9-2.	Description	2D6
9-3.	Troubleshooting	2D8
9-4.	Fuel Tanks	2D8
9-5.	Inspection and Repair of Fuel Tanks	2D8
9-6.	Removal of Inboard Fuel Tank	2D9
9-7.	Installation of Inboard Fuel Tank	2D9
9-8.	Removal of Outboard Fuel Tank	2D9
9-9.	Installation of Outboard Fuel Tank	2D9
9-10.	Removal of Inboard Fuel Tank (Optional Fuel Cell Installed)	2D10
9-11.	Installation of Inboard Fuel Tank (Optional Fuel Cell Installed)	2D10
9-12.	Removal of Outboard Fuel Tank (Optional Fuel Cell Installed)	2D10
9-13.	Installation of Outboard Fuel Tank (Optional Fuel Cell Installed)	2D10
9-14.	Removal of Optional Fuel Cell	2D10
9-15.	Installation of Optional Fuel Cell	2D11
9-16.	Cleaning and Inspection of Fuel Cells	2D11
9-17.	Fuel Cell Compartment	2D13
9-18.	Handling and Storage of Fuel Cells	2D13
9-19.	Repair of Fuel Cells	2D13
9-20.	Handling of Repair Materials	2D14
9-21.	Repair Procedures of Good Year Vithane Fuel Cells	2D14
9-22.	Repair Limitations of Fuel Cells	2D14
9-23.	Repair Patch (Heat Cure Method)	2D15
9-24.	Repair Patch (Air Cure Method)	2D17
9-25.	Defect Repairs of Fuel Cell	2D17
9-26.	Testing Fuel Cell	2D17
9-27.	Inspection of Fuel System	2D19
9-28.	Fuel Quantity Sender Unit	2D19
9-29.	Fuel Quantity Sender/Gauge Check (Installed)	2D19
9-30.	Fuel Filters	2D21
9-31.	Removal of Fuel Filter	2D21
9-32.	Disassembly of Fuel Filter	2D21
9-33.	Cleaning, Inspection and Repair of Fuel Filter	2D21
9-34.	Assembly of Fuel Filter	2D22
9-35.	Installation of Fuel Filter	2D22

Revised: 11/12/82

Paragraph	Aerofiche Grid No.
9-36. Fuel Selector Valve	2D22
9-37. Removal of Fuel Selector Valve	2D22
9-38. Disassembly of Selector Valve	2D22
9-39. Cleaning, Inspection and Repair of Selector Valve	2D23
9-40. Assembly of Selector Valve	2D23
9-41. Leak Test of Selector Valve	2D24
9-42. Installation of Fuel Selector Valve	2D24
9-43. Rigging of Selector Valve	2D24
9-44. Cleaning Fuel System	2D24
9-45. Electric Fuel Pump	2D24
9-46. Removal and Installation of Electric Fuel Pump	2D24
9-47. Auxiliary Fuel System Adjustment	2E1
9-48. Auxiliary Fuel System Operational Check	2E2
9-49. Calibration and Test of Fuel Quantity Gauges	2E2

Revised: 3/16/81

SECTION IX

FUEL SYSTEM

9-1. INTRODUCTION. The fuel system components covered in this section consist of fuel tanks, fuel selector valves, filters and electric fuel pumps. Each wing contains interconnected aluminum inboard and outboard fuel tanks, having a combined capacity of 49 U.S. gallons, for a total capacity of 98 U.S. gallons, or with optional fuel tanks installed, each wing will have a capacity of 64 U.S. gallons, for a total capacity of 128 U.S. gallons.

This section also provides instructions for removal, repair, cleaning, reassembly and testing of repairable components of the fuel system. A troubleshooting chart to assist in isolating and correcting troubles which may occur is also included.

9-2. DESCRIPTION. An independent fuel system is incorporated into each wing permitting each engine to operate from its own fuel supply. However, the two systems are interconnected by means of a crossfeed that will permit fuel from one set of tanks to be drawn by the opposite engine in the event of an emergency.

Fuel tanks form an integral part of the wing surface when installed. The inboard and outboard fuel tanks in each wing are interconnected allowing fuel from the outboard tank to flow into the inboard tank as the fuel from the inboard tank is being consumed.

Fuel flow for each system is indicated on the gauge located in the instrument panel. A fuel quantity gauge for each system, also located in the instrument panel, indicates the amount of fuel remaining as transmitted by electric fuel quantity sending units located in the wing tanks.

Fuel for each engine is drawn through a finger screen located in the inboard fuel tank to a selector valve. From the selector valve, the fuel goes through a fuel filter to the electric pump and into the engine driven pump which forces the fuel through the metering unit.

Each engine has an engine driven fuel pump that is part of the fuel injection system. On models without a primer system installation, switches for the electric fuel pumps are located on the switch panel to the left of the pilot. These electric fuel pumps, when activated, pressurize the fuel for priming and vapor suppression. An integral relief valve assures that activation of the electric fuel pump for vapor suppression will not flood the engine. On models with a primer system installed an auxiliary fuel system is provided. The purpose of the electrically powered auxiliary fuel system is to supply fuel to the engine in case of engine driven fuel pump failure or malfunction, for ground and inflight starting, and for vapor suppression. The two auxiliary fuel pump switches are located on the switch panel to the left of the pilot and consists of, three position, rocker type switches, LO, HI and center OFF. The LO auxiliary fuel pressure is selected by pushing the top of the switch. The HI auxiliary fuel pressure is selected by pushing the bottom of the switch. To prevent accidental activation of the HI position, a switch guard must be unlatched before the switch is placed in the HI position. When the HI auxiliary fuel pump is activated, an amber light near the annunciator panel is illuminated for each pump. These lights dim whenever the pump pressure reduces automatically when manifold pressure is below approximately 21 inches.

In case of a failed engine driven fuel pump, auxiliary fuel pressure may be selected. Adequate pressure and fuel flow will be supplied for up to approximately 75% power. Manual leaning to correct fuel flow will be required at altitudes above 15,000 feet and for RPM's less than 2300. An absolute pressure switch automatically selects a lower fuel pressure when the throttle is reduced below 21 in. Hg manifold pressure and the HI auxiliary fuel pump is on.

CAUTION

Excessive fuel pressure and very rich fuel/air mixtures will occur if the HI position is energized when the engine fuel injection system is functioning normally.

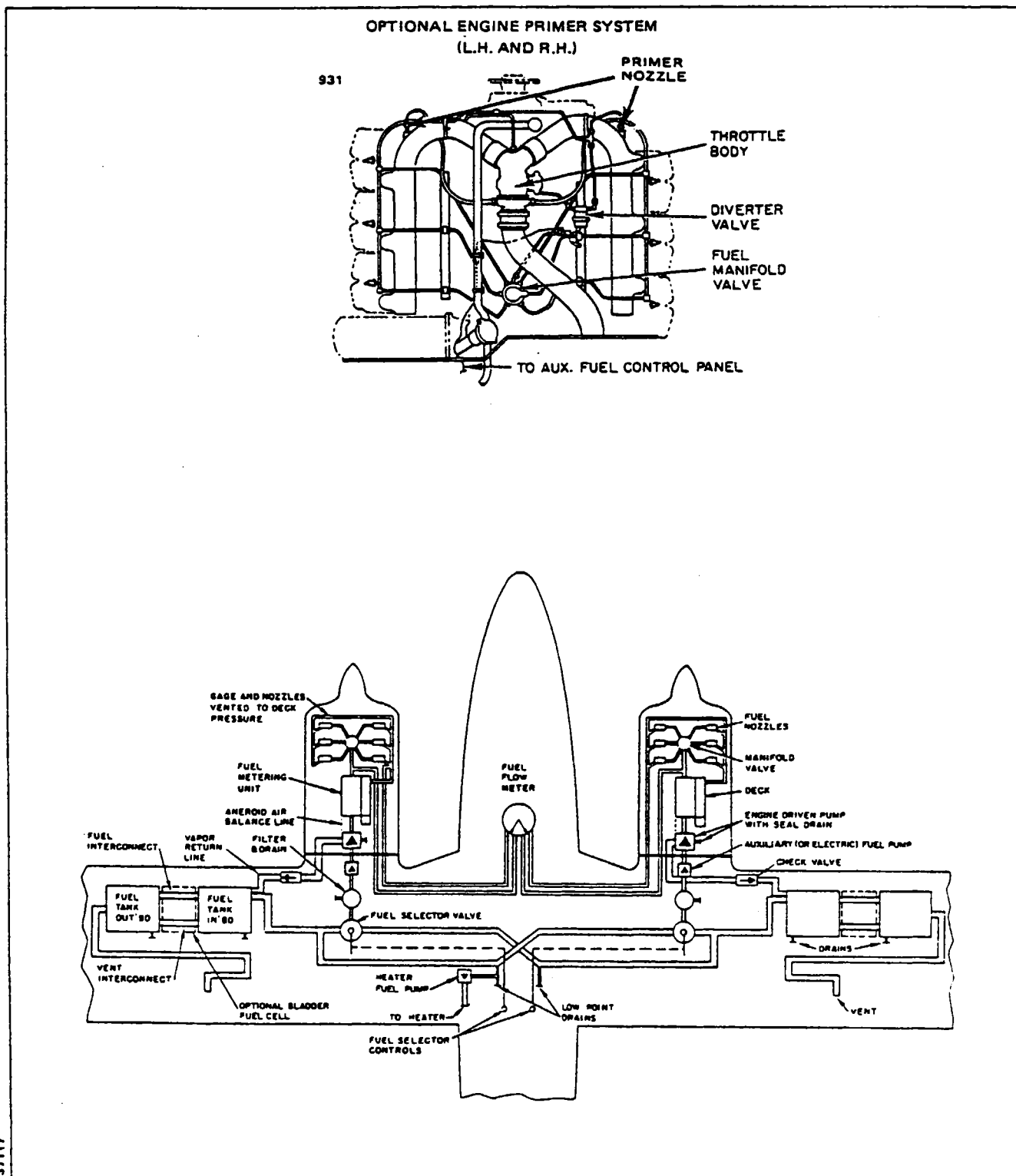

Figure 9-1. Fuel System Schematic

PIPER SENECA II SERVICE MANUAL

Low auxiliary fuel pressure is available and may be used during normal engine operation both on the ground and in flight for vapor suppression should it be necessary as evidenced by unstable engine operation during idle or at high altitudes.

There are two separate spring loaded OFF, primer button type switches, located adjacent to the starter switches. These switches are used to select the HI auxiliary fuel pump operation for priming, irrespective of other switch positions. These primer buttons may be used for both hot or cold engine starts.

On airplanes equipped with an optional engine primer system, Piper Service Kit No. 761 094v, the primer switch location and actuation is the same as the basic airplane. However, this system includes several parts not found in the basic airplane but which make up an integral part of the engine fuel system. The components of the system are an electrically operated diverter valve, located on the engine in the metered fuel supply line between the air throttle valve and the manifold valve, two primer nozzles, located in the intake manifold on each side of the engine, the interconnecting fuel lines, and fine wire spark plugs. Actuation of the engine primer switch operates the auxiliary electric fuel pump on HI and energizes the diverter valve which supplies fuel to each primer nozzle in the intake manifold. The diverter valve does not shut off all fuel flow to the manifold valve, therefore some quantity of fuel is also supplied to each cylinder nozzle during priming. Operation of the auxiliary fuel pump on HI and LO is unchanged.

9-3. TROUBLESHOOTING. Table IX-II, located in the back of this section, lists troubles which may occur in the mechanical or electrical portions of the fuel system, the probable cause and a suggested remedy. When troubleshooting, first check from the fuel supply or power source to the item affected. If the suggested remedy does not eliminate the problem, the trouble probably exists inside the component involved. It will then be necessary to remove the defective component for repair or replace it with an identical serviceable unit.

9-4. FUEL TANKS.

9-5. INSPECTION AND REPAIR OF FUEL TANKS. Fuel tanks should be completely drained before inspection. (Refer to Draining Fuel System, Section II.) Each tank should be carefully inspected for signs of leaks as indicated by telltale stains. In the event a fuel leak is detected, the fuel tank must be removed as explained in Paragraph 9-6 or 9-7, and repaired as follows:

a. The fuel tank should be sloshed in accordance with instructions provided on each can of Randolph Sloshing Sealer No. 802, (MIL-L-6047B), Piper P/N 757 572. One gallon of sealer is required for each tank. When sloshing, the finger strainer on inboard tank and fuel sender unit on both tanks must be removed before proceeding. Seal all openings. After sloshing, check for leaks using a water and soap solution and apply 1.5 pounds of air pressure. Replace finger strainer and fuel senders. If any drain valves have been removed, apply Parker Hannifin Lube Thread to male pipe threads before reinstalling. Do not allow substance to enter system.

b. If the tank being inspected has previously been sloshed, the interior of the tank should be inspected for signs of peeling or chipping sealer. Particular attention should be given the area around the filler neck (outboard tank only) as a result of the metal nozzle of the gas filler hose nicking the sealer. This inspection can best be accomplished using a mirror and inspection light through the filler neck. If peeling and/or chipping has occurred and separated material is found, the tank should be sloshed as explained in Step a.

- c. After sloshing, reinspect as outlined in Step b at intervals of 100 hours.

NOTE

The fuel tank should be replaced if it has been damaged to the extent it cannot be repaired by above procedures.

9-6. REMOVAL OF INBOARD FUEL TANK.

- a. Locate and remove cover from access hole located on underside of wing between wing station 138 and wing station 161.
- b. With fuel completely drained from tank, loosen clamps at hose connections on fuel line and fuel vent line and slide hose connections away from fuel tank.
- c. Remove screws from around the perimeter of the tank. Carefully pull tank away from the wing far enough to gain access to and remove sender wire and fuel line.
- d. The tank is now free to be removed.

9-7. INSTALLATION OF INBOARD FUEL TANK.

- a. Position fuel tank in its recess in the wing. Connect fuel line and fuel sender wires. Slide tank completely into position and secure with screws around its perimeter.
- b. Using access hole located on underside of wing, slide hose on interconnecting fuel line and fuel vent line into position and tighten clamps.
- c. Fill fuel tanks and check for leaks, unrestricted fuel flow, accurate sender indications on fuel quantity gauge, and that ground wire is securely attached to interconnecting fuel line, fuel vent line and wing rib at wing station 138.

9-8. REMOVAL OF OUTBOARD FUEL TANK.

- a. Using the same access hole described in Paragraph 9-6 and with fuel completely drained from the tank, loosen clamps at hose connections on fuel line and fuel vent line. Slide hose connections away from fuel tank.
- b. Remove screws from around the perimeter of the tank. Carefully pull tank away from the wing far enough to gain access to remove sender wires and fuel vent line located on outboard side of tank.
- c. The tank is now free to be removed.

NOTE

In the event the interconnecting fuel line and fuel vent line are being removed, it will be necessary to first disconnect the ground wire attached to the rib at wing station 138.

9-9. INSTALLATION OF OUTBOARD FUEL TANK.

- a. Position fuel tank in its recess in the wing. Connect vent line on outboard side and fuel sender wires. Slide tank completely into position and secure with screws around its perimeter.
- b. Using access hole located on underside of wing, slide hose on interconnecting fuel vent line into position and tighten clamps.
- c. Slide hose connection on interconnecting fuel line into position and tighten clamps.
- d. Fill the fuel tank and check for leaks and unrestricted fuel flow, accurate sender indications on fuel quantity gauge, and that ground wire is securely attached to interconnecting fuel line, fuel vent line and wing rib at wing station 138.

PIPER SENECA II SERVICE MANUAL

9-10. REMOVAL OF INBOARD FUEL TANK (Optional Fuel Cell Installed).

- a. Remove optional fuel cell as per Paragraph 9-14 before proceeding.
- b. With fuel tank completely drained, remove screws from around perimeter of the tank. Carefully pull tank away from the wing far enough to gain access to and remove sender wire and fuel line.
- c. The tank is now free to be removed.

9-11. INSTALLATION OF INBOARD FUEL TANK (Optional Fuel Cell Installed).

- a. Position fuel tank in its recess in the wing. Connect fuel line and fuel sender wires. Slide tank completely into position and secure with screws around its perimeter.
- b. Install optional fuel cell as per Paragraph 9-15.
- c. Fill fuel tanks and check for leaks, unrestricted fuel flow, accurate sender indications on fuel quantity gauge.

9-12. REMOVAL OF OUTBOARD FUEL TANK (Optional Fuel Cell Installed).

- a. Remove optional fuel cell per Paragraph 9-14 before proceeding.
- b. With fuel completely drained from the tank, remove screws from around the perimeter of the tank. Carefully pull tank away from the wing far enough to gain access to remove sender wires and fuel vent line located on outboard side of tank.
- c. The tank is now free to be removed.

9-13. INSTALLATION OF OUTBOARD FUEL TANK (Optional Fuel Cell Installed).

- a. Position fuel tank in its recess in the wing. Connect vent line on outboard side and fuel sender wires. Slide tank completely into position and secure with screws around its perimeter.
- b. Install optional fuel cell as per Paragraph 9-15.
- c. Fill the fuel tank and check for leaks, unrestricted fuel flow and accurate sender indications on fuel quantity gauge.

9-14. REMOVAL OF OPTIONAL FUEL CELL. (Refer to Figure 9-2.)

WARNING

Observe all fuel system fire hazard precautions throughout all removal or inspection procedures. Use vapor-proof light for inspection.

- a. Drain fuel tanks and remove fuel cell access panel (1) located on top side of wing between wing station 138 and wing station 161.
- b. Reaching through fuel cell opening, remove hose clamp (2) securing fuel cell vent nipple (4) to vent tube (5) of inboard and outboard fuel tanks.
- c. Remove wing plugs (6) from underside of wing at wing stations 138 and 161 and using a common screwdriver loosen clamp (3) securing 2 inch fuel cell interconnect nipple (7) to inboard and outboard fuel tanks.
- d. Reaching through fuel cell access hole, gently separate Velcro fasteners holding fuel cell to surrounding structure.
- e. Separate fuel cell vent nipple (4) and fuel cell interconnect nipple (7) from inboard and outboard fuel tanks.
- f. Carefully fold fuel cell and remove through fuel cell access hole.

NOTE

Pad edges of access hole to prevent possible damage to fuel cell.

9-15. INSTALLATION OF OPTIONAL FUEL CELL. (Refer to Figure 9-2.)

WARNING

Observe all fuel system fire hazard precautions throughout all installation or inspection procedures. Use vapor-proof light for inspection.

- a. Before installing fuel cell inspect airframe cavity for cleanliness.
- b. Place fuel cell into airframe cavity through access opening making sure no wrinkles exist in fuel cell upon installation.

NOTE

Pad edges of access hole to prevent possible damage to fuel cell.

- c. Install clamp (3) on fuel cell interconnect nipple and tighten finger tight.

NOTE

Position so that screw on clamp will be facing plug hole in underside of wing.

- d. Reaching into fuel cell work fuel cell interconnect nipple (7) onto interconnect fitting (8) of inboard and outboard fuel tanks.
- e. Using a common screwdriver and working through plug hole in underside of wing, tighten clamps (3). Torque should be 30 to 35 inch-pounds.
- f. Press fuel cell vent nipple (4) onto fuel tank vent fitting (5) of inboard and outboard fuel tanks. Position clamp on nipple fitting so that when tightened the screw body does not contact top of fuel cell. Torque to 15 inch-pounds.
- g. Press outward firmly on sides and top of fuel cell to engage cell with Velcro tape.
- h. Position gaskets (10) as shown in Figure 9-2. Place access panel over opening and secure with screws. Torque to 25 in. lbs. per torque valve on fuel cell.
- i. Reinsert wing plugs (6) in openings on underside of wing.
- j. Service fuel tanks and inspect for leaks.

9-16. CLEANING AND INSPECTION OF FUEL CELLS.

- a. Fuel cells may be cleaned by the following procedure:
 1. New Cells: It should not be necessary to clean new cells upon removing them from their containers, if they are installed in the airframe cavities promptly. If for any reason the cells are not installed immediately, and become dirty, they should be cleaned with soap and warm water to remove foreign material prior to installation in a clean cavity.

WARNING

Use a vapor-proof light for inspection.

2. Used Cells: Prior to removal, the cells are to be drained of fuel, purged with fresh air and swabbed out to remove all traces of fuel. Following removal, the cells are to be cleaned inside and out with soap and warm water.

PIPER SENECA II SERVICE MANUAL

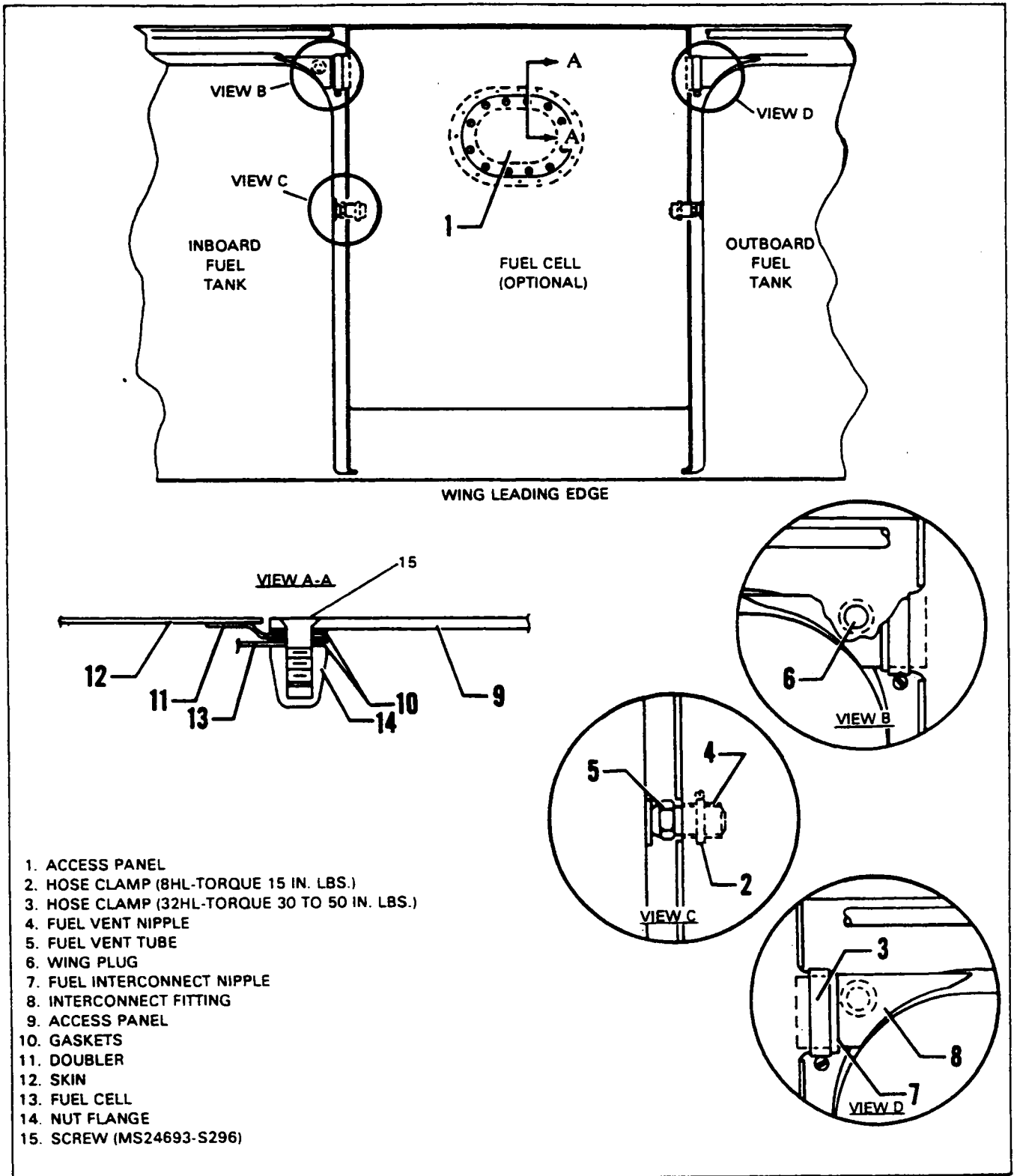

Figure 9-2. Fuel Cell Installation

Revised: 11/12/82

FUEL SYSTEM

2D12

Island Enterprises

- b. Fuel cells may be inspected by the following procedure:
 - 1. New Cells: Inspect the cell surface inside and outside for cuts, abraded (scuffed) areas and accessory damage. Also, inspect the fitting seals for nicks, scratches and foreign material.
 - 2. Used Cells: Cells removed from the airframe cavity for inspection and repair or cells being returned to service from storage, should be inspected as outlined above.

Cells installed in the airframe cavity may be inspected for possible repairs by reaching through the fuel cell access plate and taking a section of cell between the thumb and forefinger. Wipe the ridge created by this action with MEK. If fine cracks are evident, the fuel cell is not repairable.

9-17. FUEL CELL COMPARTMENT.

- a. Thoroughly clear the cell compartment of all fittings, trimmings, loose washers, bolts or nuts.
- b. Round off all sharp edges of the fuel cell compartment.
- c. Inspect the fuel cell compartment just prior to fuel cell installation.
- d. Tape over all sharp edges and all rough rivets.

9-18. HANDLING AND STORAGE OF FUEL CELLS.

WARNING

Do not permit smoking or open flame near repair area or cells.

- a. Prevent needless damage by exercising common sense care in all handling of the cells. Folding or collapsing of cells is necessary to place them in containers for storage, install in airframe cavities and carrying from place to place. Protect cell from tools, hot lights, etc., when working around them. Avoid stepping on folds or creases of cells. Do not carry cells by fittings. Maintain original cell contours or folds when refolding for boxing, rolling to insert in airframe cavities or handling in the repair area. The cells to be repaired should be placed on a well-lighted table. Maintain natural contours, if possible, while repairing. Prevent contact with sharp edges, corners, dirty floors or other surfaces. Repair area must be well-ventilated. Do not stack cells. Inspect cavities and insure cleanliness prior to installing any cell.

- b. When storing cells, observe the following rules:
 - 1. Fold cells smoothly and lightly as possible with a minimum number of folds. Place protective wadding between folds.
 - 2. Wrap cell in moisture-proof paper and place it in a suitable container. Do not crowd cell in container, use wadding to prevent movement.
 - 3. Stack boxed cells to allow access to oldest cells first. Do not allow stacks to crush bottom boxes. Leave cells in boxes until used.
 - 4. Storage area must be dry, 70° F. and free of exposure to sunlight, dirt and damage.
 - 5. Used cells must be cleaned with soap and warm water prior to storage. Dry, and box as outlined above.

9-19. REPAIR OF FUEL CELLS. The following is the repair procedure recommended for field repair of fuel cells constructed of Goodyear Vithane material. There are two methods by which these repairs may be accomplished. One method is by heat cure, the other is air cure. The end result of either repair is a neat, permanent repair. The heat repair allows the cell to be cured and ready for reinstallation in two hours while the air cure method requires that the cell not be moved for 72 hours during the air cure period.

NOTE

Air cure repairs to be made at room temperature at approximately 75° F. For each 10° drop in temperature add 20 hours cure time. For instance if room temperature reads 65° F, air cure for 92 hours instead of 72 hours.

PIPER SENECA II SERVICE MANUAL

9-20. HANDLING OF REPAIR MATERIALS.

a. All materials are to be protected from dirt contamination, sunlight, and excessive heat or cold while in storage. Containers are to be tightly capped and stored at a temperature of 70° F.

CAUTION

80C27 repair cement requires thorough mixing to obtain full adhesive values.

b. The repair cement code 80C27 referred to in this text is prepared immediately prior to use by mixing repair cement 80C27 (pint can with 320gms) with cross-linker 80C28 (4 oz. bottle with 81cc).

CAUTION

All containers for cements and solvents should be properly identified.

c. Repair cement has a pot life of 20 minutes after mixing. The unmixed 80C27 and 80C28 have a shelf life of six months from date of packaging.

9-21. REPAIR PROCEDURES OF GOODYEAR VITHANE FUEL CELLS.

NOTE

The repair of Goodyear Vithane fuel cells is restricted to authorized personnel. Authorized personnel are those who have been certified and trained by Goodyear representatives, or those who have received their training from persons who have been certified and trained by Goodyear representatives.

9-22. REPAIR LIMITATIONS OF FUEL CELLS. Repair limitations are as follows:

- a. FT-192 repair fabric is for repair of simple contours only. Patches referred to in this text are of this material.
- b. Inside patches are to lap defect edges a minimum of 1.0 inch in each direction.
- c. Outside patches are to lap defect edges .25 to .50 of an inch larger than inside patches.
- d. Outside patches are to be applied and cured prior to applying an inside patch.
- e. Blisters between inner liner and fabric, larger than .25 of an inch in diameter require an outside and an inside patch.
- f. Separations between layers or plies larger than .50 of an inch in diameter require an outside and inside patch.
- g. Slits or tears up to 6.0 inches maximum length require an outside and inside patch.
- h. External abraded or scuffed areas without fabric damage require an outside patch only.
- i. A loose edge may be trimmed, provided that .50 of an inch minimum lap or seam is maintained.

CAUTION

For each 10° drop in temperature from 75° F, add 20 hours cure time. For example, at 65° F, cure for 92 hours.

PIPER SENECA II SERVICE MANUAL

- j. Air cure repair patches are to remain clamped and undisturbed for 72 hours at room temperature of approximately 75° F.
- k. All heat cured patches are ready for use when cool.
- l. Fitting repairs are confined to loose flange edges, seal surface rework and coat stock.
- m. The maximum number of heat cure repairs in the same area is four.

NOTE

Any damage not covered by the above should be returned to The Goodyear Tire & Rubber Company, Rockmart, Georgia, for repair.

9-23. REPAIR PATCH (Heat Cure Method).

- a. Prepare exterior cell wall and exterior patch first. Cut repair patch from FT-192 material to size required to insure proper lap over injury in all directions. (See Limitations.) (Hold shears at an angle to produce a beveled edge (feather) on patch.) Round corners of patch. (Dull side or gum contact face of repair patch should be the largest surface after beveling.)
- b. Wash one square foot of cell wall surrounding injury and repair patch contact side with a clean cloth soaked with Methyl Ethyl Ketone solvent.
- c. Abrade cell wall surface about injury and contact side of patch with fine emery cloth to remove shine.
- d. Repeat Methyl Ethyl Ketone washings two more times. A total of three washings each surface.
- e. Tape a 8" x 8" piece of cellophane inside cell over injury.
- f. When all the above preparatory work has been done and cell has been positioned for patch application on repair table, mix the 80C27 cement (320 gms) with the crosslinker 80C28 (81cc), and stir mixture thoroughly for five minutes.

NOTE

Cement must be at a minimum of 70° F before mixing. Keep away from water and excessive heat.

- g. Brush one even coat of mixed repair cement on the cell wall around injury and on the contact side of repair patch. Allow to dry for fifteen minutes.

CAUTION

Do not use first can of mixed cement for this coat.

- h. Repeat a second mixing of repair cement and brush a second coat.

CAUTION

Make sure cellophane inside cell over injury remains in place as any cement will stick cell walls together without it as a separator.

- i. Allow cement to dry approximately five minutes and then center patch over injury. Lay repair patch by rolling down on surface from center to edge without trapping air. Hold the unrolled portion of repair patch off the cemented surface until roller contact insures an air-free union. At this time repair patch may be moved by hand on wet surface to improve lap. Do not lift repair patch, slide it.

PIPER SENECA II SERVICE MANUAL

FUEL CELL REPAIR EQUIPMENT INFORMATION

Repair Kit, Goodyear Drawing No. 2F1-3-37813

Group I Materials

80C27 Repair Cement	8	Pint cans, 320gms in each
80C28 Cross-Linker	8	4 oz. bottles, 81cc in each
Methyl Ethyl Ketone	2	Pint cans
FT-192 Repair Fabric	2	Sheet 12" x 12"

Group II Materials

The following equipment is necessary to perform the repair.

Group II equipment will be furnished at additional cost, if ordered by customer.

Foam Rubber Cloth Back Sheet, 1/4" x 12" x 12"	2
Paint Brush, 1 inch wide	2
Aluminum Plates, 1/4" x 6" x 6"	4
Measuring Cup (250ml)	1
Cellophane (Sheet 12" x 24")	2

Torques For Specific Nipple Fitting Sizes

Fitting Size (I.D.)	Clamp Torques (in.-lbs.)
1/4" - 1/2"	12 - 16
3/4" - 1"	15 - 20
1 1/2"	25 - 30
2"	30 - 35
3"	35 - 40

NOTES

Accessories - order per individual cell requirements.

Phenol plates, phenol plate assemblies and phenol test equipment can be ordered as required from cell manufacturer.

Cure Iron (set 240° F) optional.

j. Cover one smooth surface each of two aluminum plates (plates must be larger than patch), with fabric-backed airfoam fabric side out. Tape airfoam in place. Foam must cover edges of plate for protection. Use a cellophane separator to prevent the cement from sticking in the wrong place.

CAUTION

Make sure that cell fold is not clamped between plates. This would cause a hard permanent crease. Also make sure that patch does not move when clamp is tightened.

k. Center a repair iron 2F1-3-25721-1 on the plate over the repair patch. Secure the assembly with a "C" clamp. Tighten by hand. Check cement flow to determine pressure.

l. Connect repair iron into 110-volt electrical outlet and cure repair for two hours. After two hours cure, unplug electric and allow repair iron to cool to touch. Then remove "C" clamp. Wet cellophane to remove from repair.

CAUTION

Success of applying both an outside and inside repair patch simultaneously is doubtful and not recommended.

m. Inside patch is applied same as above procedure except for size of repair patch (see limitations) after outside patch has been cured.

9-24. REPAIR PATCH (Air Cure Method). Follow procedure for heat cure method, except omit repair iron and cure each patch per air cure limitations (minimum 72 hours), undisturbed, at 75° F.

9-25. DEFECT REPAIRS OF FUEL CELL.

- a. Blisters: Remove loose material by trimming. Apply an outside and inside repair patch.
- b. Holes, Punctures, Cuts, Tears and Deep Abraded Areas: Trim away any ragged material and apply an outside and inside repair patch.
- c. Loose Seams: Buff loose edge and contact surface with emery cloth. Wash three times with Methyl Ethyl Ketone. Apply 80C27 mixed cement two coats as with repair patch. Clamp and cure. Either method may be used. See repair patch. Loose seams may be trimmed if minimum lap remains.

9-26. TESTING FUEL CELLS. Either of the following test procedures may be used to detect leaks in the bladder cells.

- a. Soap Suds Test.
 - 1. Attach test plates to all fittings.
 - 2. Inflate the cell with air to a pressure of 1 4 psi MAXIMUM.
 - 3. Apply a soap and water solution to all repaired areas and any areas suspected of leakage. Bubbles will appear at any point where leakage occurs.
 - 4. After test, remove all plates and wipe soap residue from the exterior of the cell.
- b. Chemical Test.
 - 1. Attach test plates to all fitting openings except one.
 - 2. Make up a phenolphthalein solution as follows: Add 40 grams phenolphthalein crystals in 1 2 gallon of ethyl alcohol, mix, then add 1 2 gallon of water.
 - 3. Pour ammonia on an absorbent cloth in the ratio of 3ml per cubic foot of cell capacity. Place the saturated cloth inside the cell and install remaining test plate.
 - 4. Inflate the cell with air to a pressure of 1 4 psi MAXIMUM, and maintain pressure for fifteen minutes.

PIPER SENECA II SERVICE MANUAL

5. Soak a large white cloth in the phenolphthalein solution, wring it out thoroughly, and spread it smoothly on the outer surface of the cell. Press the cloth down to insure detection of minute leaks.

6. Check the cloth for red spots which will indicate a leak. Mark any leaks found and move the cloth to a new location. Repeat this procedure until the entire exterior surface of the cell has been covered. If red spots appear on the cloth, they may be removed by re-soaking the cloth in the solution.

7. The solution and test cloth are satisfactory only as long as they remain clean. Indicator solution that is not in immediate use should be stored in a closed rustproof container to prevent evaporation and deterioration.

After the test, remove all plates and test equipment. Allow the cell to air out.

In conducting either test outlined above, the cell need not be confined by a cage or jig, providing the 1/4 psi pressure is not exceeded.

NOTE

The chemical test is the more sensitive and preferred test.

THIS SPACE INTENTIONALLY LEFT BLANK

9-27. INSPECTION OF FUEL SYSTEM. Fill tanks with fuel. Inspect tanks and fuel line connections for leaks. If fuel tanks leak, follow instructions given in Paragraph 9-5. If fuel line connections leak, tighten clamps or replace hose connections after first draining tanks.

9-28. FUEL QUANTITY SENDER UNITS. Each fuel cell contains a sender unit which is interconnected with the other units of its particular system to provide the gauge with a combined, calibrated resistance.

The resistances of these units (1.0 ohm maximum at the empty position, and 45 ± 2 ohms at the full position) should be checked before installation and if any unit is assumed to be faulty. Full travel of the unit should be $95^\circ \pm 2^\circ$.

9-29. FUEL QUANTITY SENDER/GAUGE CHECK (INSTALLED). Fuel quantity sender units and fuel quantity gauges can be checked while mounted in the airplane by using the following procedure:

- a. Put the fuel selector levers in the "OFF" position. Completely drain fuel tanks that relate to the fuel quantity senders and gauge to be checked. (Refer to Draining Fuel System, Section II.)
- b. Level airplane laterally (refer to Leveling, Section II) and position the aircraft with a 1° nose up attitude.

NOTE

The electrical system should supply 12 to 14-volts to the gauge.

c. With the master switch in the "OFF" position, the gauge needle should be centered on the white dot to the left of the "O" radial mark, with a maximum deviation of $1/4$ needle width. If not within this tolerance, the gauge should be replaced.

d. With the master switch in the "ON" position and no fuel in the tanks, the gauge needle should be centered on the white dot to the left of the "O" radial mark with a maximum deviation of $1/4$ needle width. If not within this tolerance, the gauge should be replaced.

e. Place 2- $1/2$ gallons of fuel in the wing fuel tank that relates to the gauge and sender unit being checked.

f. With 12 to 14-volts DC supplied to the electrical system and the master switch in the "ON" position, the needle should be centered on the "O" radial mark: plus 0, minus 1 needle width.

g. If the needle does not read within the above tolerance, remove the sender wire from the rear of the gauge and check the resistance to ground through the sender circuit. If the resistance is not within 6.5 ± 0.5 ohms, replace the inboard sender. Then, recheck as specified above.

h. Add fuel to the tanks in accordance with the information given in Table IX-1 until tanks are full. Observe the gauge reading at each 10 gallon increment.

i. With the tanks full and master switch "ON," the needle should be centered on the "F" radial mark within ± 1 needle width. If not within this tolerance, adjust the electrical adjustment (refer to Figure 9-3) adjust sufficiently to bring it within tolerance; do not center the needle.

NOTE

All adjustments required on gauges shall be accomplished using a non-magnetic screwdriver.

PIPER SENECA II SERVICE MANUAL

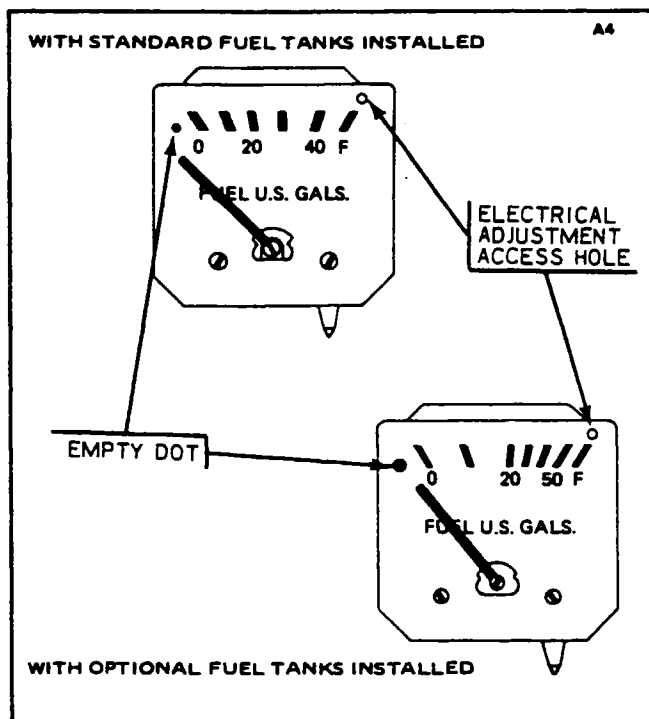

Figure 9-3. Fuel Gauges

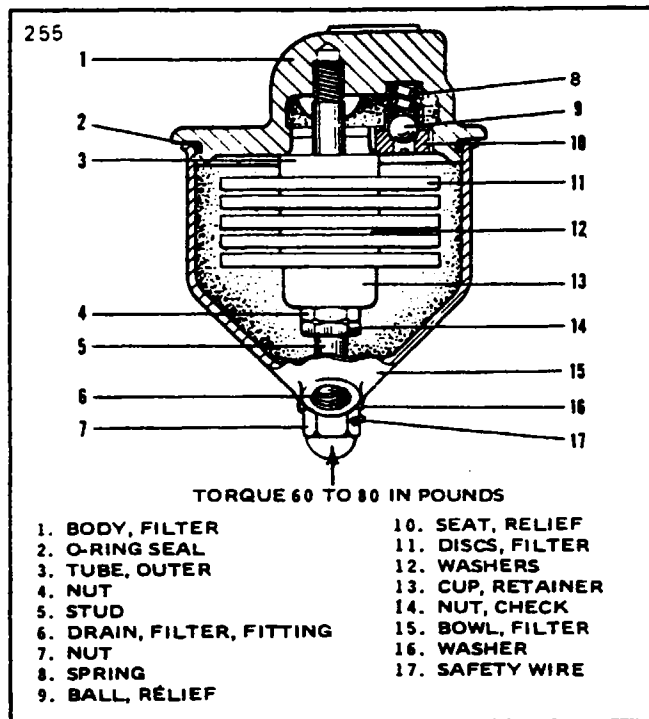

Figure 9-4. Fuel Filter

TABLE IX-1. FUEL QUANTITY SENDER/GAUGE TOLERANCES

STANDARD FUEL SYSTEM			OPTIONAL FUEL SYSTEM		
Actual Fuel Within Tanks (U.S. Gallons)	Gauge Reading (U.S. Gallons)	Total Resistance Of Senders (Ohms)	Actual Fuel Within Tanks (U.S. Gallons)	Gauge Reading (U.S. Gallons)	Total Resistance Of Senders (Ohms)
10	10 (+1)	26	10	10 (+1)	26
20	20 (+2)	44	20	20 (+2)	39
40	40 (+2)	80	50	50 (+2)	74
NOTE: Values in parentheses are needle-width tolerances.					

9-30. FUEL FILTERS.

9-31. REMOVAL OF FUEL FILTER. (Refer to Figure 9-4.) The instructions given are for the removal of the complete filter from the airplane. For cleaning and servicing purposes, only Steps a and b of this paragraph are necessary; then proceed to Paragraph 9-32.

- a. Position the fuel selector valve to the OFF position.
- b. Remove the access panel forward of the main spar, at wing station 91.00, on the bottom of the wing panel.
- c. Disconnect the filter drain line and fuel lines from the filter assembly. Cap the line ends to prevent contamination.
- d. Remove the bolts that secure the filter to its mounting bracket and remove the filter from the aircraft.

9-32. DISASSEMBLY OF FUEL FILTER. (Refer to Figure 9-4.)

- a. Cut safety wire (17) and remove cap nut (7) from the bottom of the filter bowl (15).
- b. Remove the bowl from the filter body (1).
- c. The O-ring seal (2) may be removed from the body.
- d. Loosen and remove both the check nut (14) and nut (4) from the stud (5) that holds the filter cartridge subassembly.
- e. Slide the filter cartridge from the stud. The filter discs (11) and washers (12) need not be separated from the element outer tube (3) for normal cleaning.
- f. If necessary to disassemble the filter cartridge, remove the retainer cup (13) from the outer tube (3) and slide discs (11) and washers (12) from the outer tube. Do not use a screwdriver or sharp tool that may damage the discs.
- g. The filter bypass assembly may be removed by using the proper size screwdriver and turning out the relief seat (10). Remove relief ball (9) and spring (8).

9-33. CLEANING, INSPECTION AND REPAIR OF FUEL FILTER.

- a. Carefully remove the filter pack from the housing and remove all O-rings, valves, springs, etc. Do not disassemble the filter pack from the center tube at this time.
- b. Plug the open ends of the filter and immerse in oil solvent such as Stoddard solvent. Let soak for 30 to 60 minutes.
- c. Metal valve parts may also be soaked in this cleaner.
- d. Remove filter and parts (if any) from the cleaner and rinse thoroughly in clean hot flowing tap water.
- e. Drain or blow off with filtered low pressure air to dry.
- f. Inspect the filter discs for damage and/or broken screens.
- g. Check condition of bowl O-ring seal (2) and washer (6).
- h. Check for corrosion of filter parts.
- i. Check movement of bypass valve.
- j. Normal repairs necessary for the filter are replacement of bowl gaskets and damaged filter discs.

PIPER SENECA II SERVICE MANUAL

9-34. ASSEMBLY OF FUEL FILTER. (Refer to Figure 9-4.)

- a. If removed, install bypass valve spring (8), relief ball (9) and seat (10).
- b. Place the filter pack (assembled) on the housing stud (5). Ascertain that the end of the outer tube (3) has positioned itself in the filter body (1).
- c. Secure the filter pack with nut (4). Torque nut 10 to 15 inch-pounds. Torque check nut (14) against nut (4) 40 to 60 inch-pounds.
- d. Place the O-ring packing (2) on the housing and install bowl (15), washer (16) and cap nut (7). Torque cap nut 60 to 80 inch-pounds and safety.
- e. Install the filter in the aircraft. If the filter was not removed, proceed to Step c of Paragraph 9-35.

9-35. INSTALLATION OF FUEL FILTER.

- a. Position the filter assembly into the wing. Ascertain that it is positioned properly and secure to its mounting bracket with two bolts.
- b. Connect the drain line to the filter bowl.
- c. Connect the fuel lines to the filter assembly.
- d. Turn the fuel selector to the ON position and check for any fuel leaks.
- e. Install the access plate.

9-36. FUEL SELECTOR VALVE.

9-37. REMOVAL OF FUEL SELECTOR VALVE.

- a. The fuel selector valve need not be removed unless any of the following conditions exist:
 1. Failure of selector lever to seat in detent.
 2. Signs of leakage.
 3. Difficulty in moving fuel selector lever.
- b. In the event it is necessary to remove the fuel selector valve, remove access plate located forward of the main spar on the underside of the wing and outboard of the nacelle.
- c. Drain appropriate fuel tank. (Refer to Draining Fuel Tank, Section II.)
- d. Disconnect control cable from valve selector lever. Disconnect fuel lines and mounting hardware and remove fuel selector valve.

NOTE

Except for replacement of O-rings, the fuel selector valve should be overhauled only when necessary. To remove and replace O-rings, follow instructions in Paragraphs 9-37 and 9-40.

9-38. DISASSEMBLY OF SELECTOR VALVE. (Refer to Figure 9-5.)

- a. Remove the four screws (14) and washers (15) that attach the cap assembly (9) to the valve body (2).
- b. Pull the cap assembly straight from the valve body (2).
- c. Push the spool (12) from the valve body.
- d. To disassemble the cap assembly (9), remove the roll pin (3) that secures the gear (21) on its shaft (4) by driving the pin with a 3/32 straight drift punch.
- e. Remove the gear and spacer (8) from the shaft.
- f. Remove the four screws (13) that secure the packing and seal cover (6). Remove the cover.
- g. Remove old O-rings and seal.
- h. If fitting (11) is removed, replace O-ring packing (17).

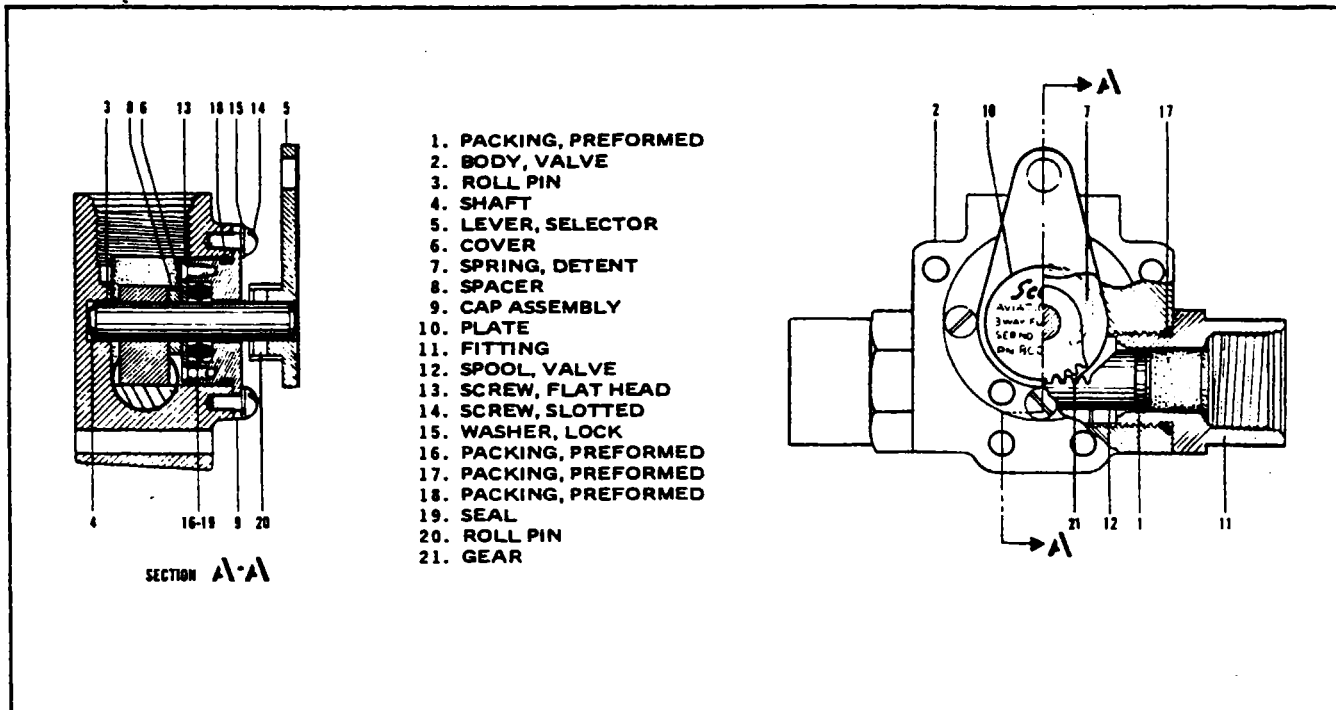

Figure 9-5. Fuel Selector Valve

9-39. CLEANING, INSPECTION AND REPAIR OF SELECTOR VALVE.

- a. Clean the valve components in a dry cleaning solvent.
- b. Inspect the valve for the following:
 1. Check that the friction surfaces of the valve are free from nicks, dents and burrs.
 2. Check that the teeth of the gear and spool are not damaged.
 3. Check that the threaded surfaces are not stripped or cross-threaded.
 4. Check that the selector detent mechanism is operating properly.
- c. Repair to the valve is limited to reconditioning of parts, such as smoothing out minor nicks and scratches and the replacing of O-ring packings and seal.

NOTE

Fittings (11) in valve are special. Do Not use AN fittings.

9-40. ASSEMBLY OF SELECTOR VALVE. (Refer to Figure 9-5.)

- a. If either fitting (11) was removed, install the O-ring packing (17) and assemble the fitting on the valve body (2).
- b. Lubricate the O-ring packings (17) with a thin coat of stop-lock grease and install on the valve spool (12).
- c. Insert and center the spool in the valve body.
- d. Lubricate the seal (19) and O-ring (16) and install in the cap assembly (9).
- e. Ascertain that the shaft (4) is in place and install cover (6). Secure with screws (13).
- f. Slide the spacer (8) and gear (21) on the shaft, with the pinholes aligned so that the gear teeth are opposite the selector lever (5). Secure the gear with roll pin (3).

PIPER SENECA II SERVICE MANUAL

- g. Install the O-ring packing (18) on the cap assembly.
- h. Place the selector handle in neutral in relation to the cap and install the cap assembly in the valve body. Secure the cap assembly with screws (14) and washers (15).
- i. Check valve operation.

9-41. LEAK TEST OF SELECTOR VALVE.

- a. Connect the inlet port of the valve assembly to a 25 psi air source.
- b. Plug the right-hand port and close the left-hand port by placing the control lever to the right.
- c. Apply pressure to 25 psi. There shall be no evidence of leakage either through the port or around the fitting and lever when submerged in kerosene or a similar petroleum base fluid for 30 seconds.
- d. Depressurize; remove the plug from the right-hand port; place on left-hand port and close right-hand port by placing the lever to left.
- e. Repeat Step c.
- f. Disconnect and wipe fluid from exterior.

9-42. INSTALLATION OF FUEL SELECTOR VALVE.

- a. Position the selector valve in the wing with control lever down and center port forward. Secure to mounting bracket with four screws and nuts.
- b. Connect fuel lines to valve and control cable to selector lever.
- c. Refer to Paragraph 9-43 for rigging of selector valve. Install access panel.

9-43. RIGGING OF SELECTOR VALVE.

- a. Remove the access panel located on the underside of the wing, forward of the main spar, outboard of the nacelle.
- b. Ascertain that the control cable is connected to the selector valve and that the valve is in its center OFF position. Lubricate the external parts of the selector valve sprocket and control cable attachment ends with ESSO "Beacon 325" grease or equivalent (MIL-G-3278).
- c. Place the fuel selector handle in the cockpit, in its OFF position. (The levers centered on the OFF position of the cover placard.) Adjust and connect the cable end to the cockpit lever.
- d. Actuate the selector to ascertain that the valve moves into its three detent positions and the control levers have a positive clearance between the lever and cover assembly.
- e. Reinstall the access panel.

9-44. CLEANING FUEL SYSTEM.

- a. To flush fuel tank and selector valve, disconnect the fuel line from the injector.
- b. Select a fuel tank; turn on the electric pump and flush fuel through the system until the tank is empty. Agitation of the fuel within the tank during this operation will help pick up and remove dirt and other foreign matter from the fuel tank and selector valve.
- c. Repeat this procedure for each fuel tank.
- d. When all tanks are flushed, clean filter and fuel tank finger screens.

9-45. ELECTRIC FUEL PUMP.

9-46. REMOVAL AND INSTALLATION OF ELECTRIC FUEL PUMP. There is one electric rotary vane type fuel pump for each engine. The pump is mounted in a bracket on the aft side of the fire wall. To remove pump, proceed as follows:

- a. Remove rectangular hatch assembly located on the top of the nacelle, aft of the fire wall.
- b. Remove fuel lines from the pump and disconnect the electrical leads.
- c. Remove straps holding pump in position and withdraw pump through hatch opening.

- d. Do not attempt disassembly or repair of the fuel pump. If fuel pump proves to be defective, it should be replaced.
- e. Reinstall pump in reverse order of removal.

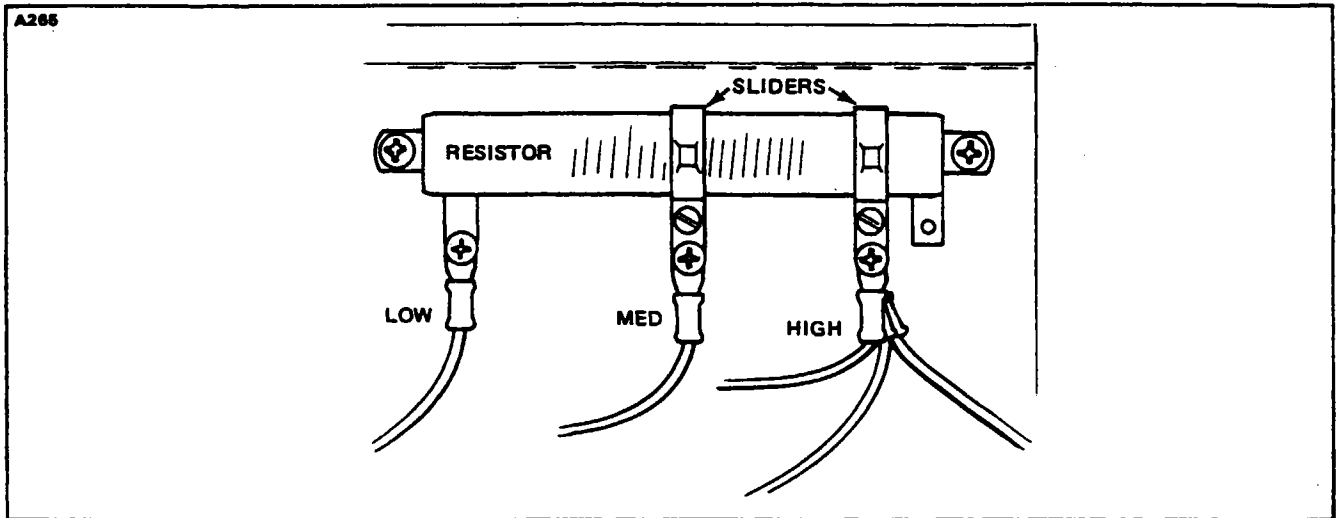

Figure 9-6. Slider Resistor Terminal, Right or Left (Looking Aft)

9-47. AUXILIARY FUEL SYSTEM ADJUSTMENT. Adjustment of the auxiliary fuel system if installed is accomplished as follows for each engine:

- a. Remove the access panels from the top of each engine nacelle to gain access to the slider resistor mounted on the nacelle bulkhead.
- b. Install a calibrated pressure gauge (31 to 37 psi) in the fuel line forward of the firewall.
- c. Pull the circuit protector (for the auxiliary fuel pump which is to be adjusted) to the off position and insure that the aircraft master switch is in the off position also.
- d. Connect the negative lead from an external DC power source to ground on the aircraft and the positive lead to the slider resistor high position. (Refer to Figure 9-6.)
- e. Using a calibrated voltmeter, adjust the external power source to indicate 12.0 to 12.5 volts DC at the auxiliary fuel pump. Note the voltage reading on the external power source voltmeter.
- f. The calibrated pressure gauge should indicate 31 to 37 psi.
- g. Connect the positive lead from the external power source to the slider resistor low position. (Refer to Figure 9-6.) Adjust the power supply voltage level to the same voltage obtained in Step e.
- h. Adjust the slider on the variable resistor to obtain a pump pressure of 8 to 10 psi. Readjust the power supply and slider to insure a pump pressure of 8 to 10 psi, at the power supply voltage noted in Step e, then secure the slider in position on the resistor.
- i. Disconnect the manifold pressure switch located on the firewall, and connect the positive lead from the power supply to the slider resistor medium position.
- j. Adjust the power supply voltage level to the same voltage obtained in Step e.
- k. Adjust the slider on the variable resistor to obtain a pump pressure of 23.5 to 24.5 psi. Readjust the power supply and slider to insure a pump pressure of 23.5 to 24.5 psi, at the power supply voltage noted in Step e, then secure the slider in position on the resistor and reconnect the manifold pressure switch.
- l. Perform Steps a thru k on the opposite engine, then reinstall the access panels.

PIPER SENECA II SERVICE MANUAL

m. If the aircraft is equipped with an optional fuel diverter valve, operate the primer switch and insure that the diverter valve is being energized. Release the primer switch and operate the fuel pump switch in the Hi-Boost position and insure that the fuel pump operates and that the diverter valve does not.

n. Remove calibrated pressure gauge unless auxiliary fuel system operational check (in following paragraph) is to be performed.

o. Refer to Section VIII, Paragraph 8-60, Engine Setup Procedures, for additional adjustments relating to the power plant fuel control system.

9-48. AUXILIARY FUEL SYSTEM OPERATIONAL CHECK

PPS50026D

a. Disconnect the external power source from the aircraft.

b. Disconnect the electrical leads from the manifold pressure switch located on the firewall.

c. Insure that all cockpit controllable electrical equipment switches are in the off position, except as directed in the following steps.

d. Turn the aircraft master switch on.

e. Place the electric fuel pump switch in the "low" position.

f. The calibrated fuel pressure gauge (should indicate a pressure increase which would indicate that the pump is operating. This pressure should not exceed 10 psi.

g. Place the electric fuel pump switch in the "hi" position.

h. The calibrated fuel pressure gauge should indicate a pressure above that noted in step f. This pressure should not exceed 24.5 psi.

i. Place the aircraft master switch in the off position.

j. Reconnect the leads to the manifold pressure switch.

k. With the fuel pump switch still in the "high" position, return the master switch to the on position.

l. The calibrated pressure gauge should indicate a pressure above the pressure noted in step h. This pressure should exceed 37 psi.

m. Place the fuel pump switch in the off position and depress the prime switch. The calibrated pressure gauge shall indicate a pressure above that noted in step h. This pressure should not exceed 37 psi.

n. Repeat these tests on other engine.

o. Remove calibrated fuel gauge.

9-49. CALIBRATION AND TEST OF FUEL QUANTITY GAUGES.

PPS60032K

a. Before placing the gauge in the cluster housing, place it in an upright level position and adjust the needle to point to the dot to the left of the "O" line, using the mechanical adjustment provided on the rear of the gauge.

NOTE

Use a non-magnetic screwdriver to accomplish all adjustments to the gauge.

b. Install the gauge in the cluster housing. (This will ground the gauge to the cluster housing, through the ground clip.)

c. Fabricate a tester as shown in Figure 9-6a. Hook it up to the gauge as shown.

d. With the selector switch in the "B" position (corresponding to the highest numbered radial mark). Center the gauge needle on that mark using the electrical adjustment located behind the adjustment hole in the face of the instrument.

e. Place the selector switch in the zero resistance position. The gauge needle should be centered on the dot at the left of the "O" mark $\pm \frac{1}{2}$ needle width.

C276

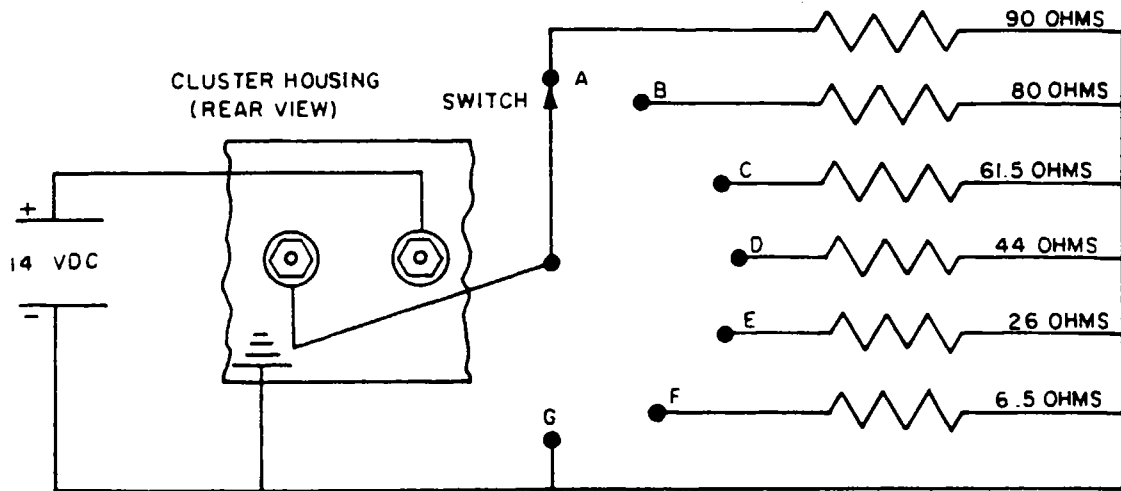

TEST SET-UP, GAUGES 96899 AND 38224-0

FIGURE 1

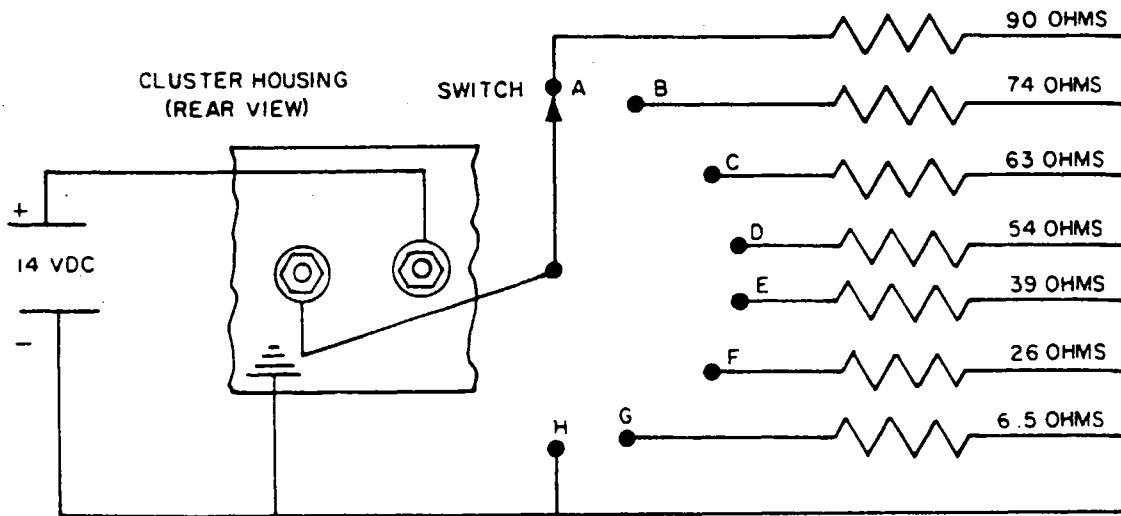

TEST SET-UP, GAUGE 38224-2

Figure 9-6a. Resistor Set-up/ Test for Fuel Quantity Gauge

Added: 3/16/81

2E3

FUEL SYSTEM

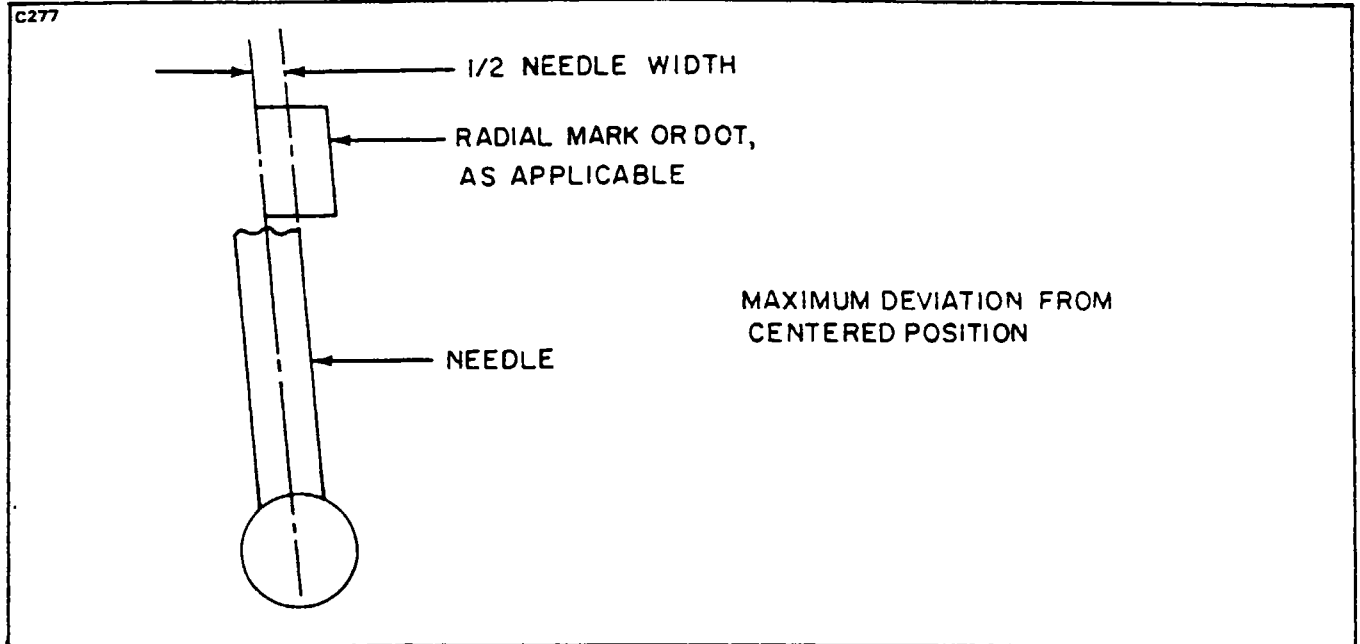

Figure 9-6b. Maximum Deviation of Fuel Quantity Gauge Needle

- f. Place the selector switch in the 6.5 ohms resistance position. The gauge needle should be centered on the "O" radial mark $\pm 0 - \frac{1}{2}$ needle width.
- g. Sequentially place the selector switch in the positions shown in Table IX-II. The gauge needle should center on the radial mark indicated within the given tolerance.

TABLE IX-II. FUEL GAUGE READING TOLERANCES

Switch Position	GAUGE P/N 38224-0		GAUGE P/N 38224-2	
	Radial Mark	Tolerance (Needlewidths)	Radial Mark	Tolerance (Needlewidths)
F			10	$\pm \frac{1}{2}$
E	10	$\pm \frac{1}{2}$	20	± 1
D	20	± 1	30	± 1
C	30	± 1	40	± 1
B	40	± 1	50	± 1
A	F	± 1	F	± 1

- h. Drain aircraft fuel system, if not previously accomplished.
- i. Add sufficient fuel to left and right wing tank system to allow verification that all fuel trap cavities are filled. Drain excess fuel.
- j. Add $2\frac{1}{2}$ gallons of fuel in the left wing fuel tank and $2\frac{1}{2}$ gallons of fuel in the right wing fuel tank.
- k. With 12-14 VDC supplied to the electrical system, the needle shall be centered on the "O" radial mark, $\pm 0 - 1$ needle width. If the needle does not read within this tolerance, replace the gauge. If replacing the gauge does not remedy the problem, check the sender. Recheck as specified above.

PIPER SENECA II SERVICE MANUAL

TABLE IX-III. GAUGE READINGS/RESISTANCE WITH FUEL IN TANKS

Model	Total Fuel in Tanks (Each Side) (Gallons)	Required Gauge Reading	Tolerance ±Needlewidths	Resistance (Reference) (Ohms, Both Senders)
Without Bladder Tanks	10	10	1	26
	20	20	2	44
	40	40	2	80
With Bladder Tanks	10	10	1	26
	20	20	2	39
	50	50	2	74

PPS80032K

l. With 14 VDC supplied to the electrical system, master switch in the off position and fuel already in the tanks as specified in step j add fuel to the left and right tanks to total quantities shown in Table IX-III. The fuel quantity readings should be as specified at each increment. If the readings are not within the stated tolerances, check the resistance of the senders, referring to Table IX-III.

m. If it is necessary to adjust the gauge at the 30, 40 or 50 gallon position, recheck the gauge as in steps k and l. To insure that the gauge is still within tolerance as shown in Table IX-III.

PIPER SENECA II SERVICE MANUAL

TABLE IX-IV. TROUBLESHOOTING CHART (FUEL SYSTEM)

Trouble	Cause	Remedy
<p>Failure of fuel to flow.</p>	<p>Fuel line blocked.</p> <p>Fuel vent cap blocked.</p> <p>Mechanical or electrical fuel pump failure.</p> <p>Fuel selector valve in improper position.</p> <p>Damaged fuel selector valve.</p>	<p>Flush fuel system.</p> <p>Check and clean vent hole in cap.</p> <p>Check and replace if necessary.</p> <p>Reposition as required.</p> <p>Check for obstructions in the fuel selector leverage mechanism.</p> <p>Check fuel selector cable for freedom of movement.</p> <p>Replace fuel selector valve.</p>
<p>Fuel quantity gauge fails to operate.</p>	<p>Broken wire.</p> <p>Gauge inoperative.</p> <p>Fuel sender float partially or completely filled with fuel.</p> <p>Circuit breaker open.</p> <p>Float and arm assembly of fuel sender sticking.</p> <p>Bad ground.</p>	<p>Check and repair.</p> <p>Replace gauge.</p> <p>Replace sender.</p> <p>Check and reset.</p> <p>Check.</p> <p>Check for good contact at ground lip or rear of gauge.</p>

PIPER SENECA II SERVICE MANUAL

TABLE IX-IV. TROUBLESHOOTING CHART (FUEL SYSTEM) (cont.)

Trouble	Cause	Remedy
<p>No fuel pressure indication.</p>	<p>Fuel selector valve stuck.</p> <p>Fuel tanks empty.</p> <p>Defective gauge.</p> <p>Fuel selector valve in improper position.</p>	<p>Check fuel selector valve.</p> <p>Check fuel tanks and fill.</p> <p>Replace gauge.</p> <p>Reposition fuel selector valve lever.</p>
<p>Low pressure or pressure surges.</p>	<p>Obstruction in inlet side of pump.</p> <p>Air in line to pressure gauge.</p>	<p>Trace lines and locate obstruction.</p> <p>Bleed line.</p>
<p align="center">NOTE</p> <p align="center">Refer to Table VIII-VII for additional Fuel System Troubleshooting.</p>		

SECTION X

INSTRUMENTS

Paragraph	Aerofiche Grid No.
10-1. General	2E11
10-2. Non-Electrical Instruments	2E11
10-3. Gyro Pressure System	2E11
10-4. General	2E11
10-5. Troubleshooting	2E11
10-6. Gyro Pressure Gauge	2E11
10-7. General	2E11
10-8. Troubleshooting	2E11
10-9. Pressure Regulating Valve	2E11
10-10. General	2E11
10-11. Troubleshooting	2E11
10-12. Adjustments to Pressure Regulator	2E13
10-13. Removal and Installation	2E15
10-14. Pneumatic Pump	2E15
10-15. General	2E15
10-16. Troubleshooting	2E15
10-17. Removal and Installation	2E15
10-17a. Replacing Pump Fittings	2E15
10-18. Pitot-Static System	2E19
10-19. Directional Gyro	2E19
10-20. General	2E19
10-21. Troubleshooting	2E20
10-22. Removal and Replacement	2E20
10-23. Gyro Horizon	2E20
10-24. General	2E20
10-25. Troubleshooting	2E21
10-26. Removal and Replacement	2E22
10-27. Rate of Climb Indicator	2E22
10-28. General	2E22
10-29. Troubleshooting	2E22
10-30. Removal and Replacement	2E23
10-31. Sensitive Altimeter	2E23
10-32. General	2E23
10-33. Troubleshooting	2E23
10-34. Removal and Replacement	2E24
10-35. Airspeed Indicator	2F1
10-36. General	2F1
10-37. Troubleshooting	2F1
10-38. Removal and Replacement	2F1

Revised: 8/10/80

Paragraph

Aerofiche
Grid No.

10-39.	Magnetic Compass	2F2
	10-40. General	2F2
	10-41. Adjustment of Compass	2F2
	10-42. Troubleshooting	2F2
10-43.	Manifold Pressure Gauge System.	2F4
	10-44. General	2F4
	10-45. Troubleshooting	2F4
	10-46. Removal and Replacement	2F5
10-47.	Tachometer Indicator	2F5
	10-48. General	2F5
	10-49. Troubleshooting	2F5
	10-50. Removal and Replacement	2F6
10-51.	Engine Oil Pressure Gauge	2F6
	10-52. General	2F6
	10-53. Troubleshooting	2F6
	10-54. Removal and Replacement	2F7
10-55.	Electrical Instruments	2F8
10-56.	Turn and Bank Indicator	2F8
	10-57. General	2F8
	10-58. Troubleshooting	2F8
	10-59. Removal and Replacement	2F8
10-60.	Fuel Quantity Indicator	2F8
	10-61. General	2F8
	10-62. Troubleshooting	2F9
	10-63. Removal and Replacement	2F9
10-64.	Oil Temperature Indicator	2F9
	10-65. General	2F9
	10-66. Troubleshooting	2F10
	10-67. Removal and Replacement	2F10
10-68.	Ammeter	2F10
	10-69. General	2F10
	10-70. Troubleshooting	2F10
	10-71. Removal and Replacement	2F10
	10-72. Removal and Replacement of Face Mounted Instruments	2F10
	10-73. General	2F10
	10-74. Removal and Replacement of Cluster Mounted Instruments	2F12
	10-75. General	2F12

Revised: 8/10/80

Paragraph	Aerofiche Grid No.
10-76. Exhaust Gas Temperature Gauge	2F12
10-77. General.....	2F12
10-78. Removal of EGT Probe and Gauge	2F12
10-78a. Cleaning and Inspection	2F12
10-78b. Installation of EGT Probe and Gauge	2F12
10-79. Troubleshooting	2F13
10-80. Cylinder Head Temperature Gauge	2F13
10-81. General.....	2F13
10-82. Troubleshooting	2F14
10-83. Removal and Replacement	2F14
10-84. Fuel Flow Gauge	2F14
10-85. General.....	2F14
10-86. Troubleshooting	2F14
10-87. Removal and Replacement	2F15
10-88. Piper AutoControl System	2F15
10-89. Annunciator Panel.....	2F15
10-90. General.....	2F15
10-91. Troubleshooting	2F15
10-92. Removal and Replacement	2F15

SECTION X
INSTRUMENTS

10-1. GENERAL. The instrumentation in the Seneca II is designed to give a quick and actual indication of the attitude, performance and condition of the airplane. Maintenance, other than described in these sections, shall be done by the instrument manufacturer or an authorized repair station.

The two types of instruments have been classified in this section as non-electrical and electrical. The first part of this section will pertain to maintenance and troubleshooting of all the instruments and their systems which depend on non-electrical sources for their operation. The remaining portion of this section is directed to maintenance and troubleshooting of all the electrically operated instruments.

10-2. NON-ELECTRICAL INSTRUMENTS.

10-3. GYRO PRESSURE SYSTEM.

10-4. GENERAL. The gyro pressure system is a dry pneumatic engine driven pump system that produces sufficient air pressure which is regulated to operate the attitude and directional gyros. The system consists of two engine driven pneumatic pumps, pressure regulators, in line filters, manifold assembly, pressure gauge, and the necessary tubing and hoses. The system operates at a preset pressure which is monitored at the pressure gauge mounted in the right side of the instrument panel.

10-5. TROUBLESHOOTING. (Refer to Table X-I, Pressure System.)

10-6. GYRO PRESSURE GAUGE.

10-7. GENERAL. The gyro pressure gauge monitors the regulated gyro system pressure. The gauge is mounted in the lower right side of the instrument panel and is calibrated in inches of mercury. The gauge has two red malfunction indicator buttons.

10-8. TROUBLESHOOTING. (Refer to Table X-I.)

10-9. PRESSURE REGULATING VALVE.

10-10. GENERAL. The pressure regulating valves regulate gyro system pressure at 4.8 to 5.1 inches of mercury for S/N up to 34-8170091 inclusive or 4.8 to 5.2 inches for S/N 34-8170092 and up. The regulating valves are mounted on the aft side of the firewall, and are adjustable to provide the correct system pressure. Incorporated in each valve is an electrical switch that completes a circuit to provide a visual display on the annunciator panel whenever gyro air pressure is insufficient.

10-11. TROUBLESHOOTING. (Refer to Table X-I.)

PIPER SENECA II SERVICE MANUAL

TABLE X-I. GYRO PRESSURE SYSTEM

Trouble	Cause	Remedy
No pressure indication at instrument.	<p>Filter clogged or dirty.</p> <p>Line from pump to filter restricted or leaking.</p> <p>Faulty gauge or malfunctioning pump.</p>	<p>Clean or replace filter.</p> <p>Check line.</p> <p>Replace gauge.</p> <p>Replace pump.</p>
Low system pressure.	<p>Filter dirty.</p> <p>Pressure regulator valve incorrectly adjusted.</p> <p>Line from pump to filter restricted or leaking.</p> <p>Line from pump to manifold leaking.</p>	<p>Clean or replace filter.</p> <p>Adjust regulator valve in accordance with adjustments in this section.</p> <p>Repair line.</p> <p>Check all lines and fittings.</p>
Pressure correct on ground but will not maintain pressure at altitude.	<p>Pump malfunctioning.</p> <p>Dirty filter.</p> <p>Regulator sticky.</p>	<p>Replace pump.</p> <p>Replace filter.</p> <p>Clean regulator.</p>
Pressure correct but pilot reports pressure erratic or shows complete loss in flight.	<p>Regulator sticky.</p> <p>Oil in pump due to leaky engine seal or cleaning fluid blown into pump while cleaning engine.</p>	<p>Clean regulator.</p> <p>Replace pump.</p>

TABLE X-I. GYRO PRESSURE SYSTEM (cont.)

Trouble	Cause	Remedy
Pressure can only be maintained at full throttle on ground.	Leak in system. Worn pump. Stuck regulator.	Repair or replace lines. Replace pump. Clean or replace regulator.
Normal pressure indication but sluggish operation of instruments. High system pressure.	Faulty flight instrument. Regulator incorrectly adjusted. Regulator sticking.	Replace instrument. Adjust regulator. Clean and check operation of regulator.
Regulator cannot be adjusted to produce correct pressure.	Lines leaking. Dirty filter. Pump malfunctioning.	Check lines and fittings. Replace filter. Replace pump.

10-12. ADJUSTMENTS TO PRESSURE REGULATOR. (Refer to Figure 10-1.)

- a. Remove nacelle cover to gain access to the pressure regulator.
- b. For S/N up to 34-8170091 inclusive:

Operate both engines at 2575 RPM; the gyro pressure gauge reading should be 4.8 to 5.1 inches of mercury.

NOTE

The pressure indicator with one engine at a time running at 2000 RPM should be within .1 inches of mercury of each other. With both engines operating at 2575 RPM, the reading should not exceed 5.2 inches of mercury.

For S/N 34-8170092 and up:

1. Set pressure regulator for one engine at 4.8 to 5.2 inches of mercury with that engine operating at magneto check RPM and other engine at idle or off.
2. Repeat setting procedure for other engine.

PIPER SENECA II SERVICE MANUAL

1982

1. PUMP
2. AIR FILTER
3. INLINE FILTER
4. ATTITUDE GYRO, COPILOT
5. DIRECTIONAL GYRO, COPILOT
6. PRESSURE GAUGE
7. ATTITUDE GYRO
8. DIRECTIONAL GYRO
9. PRESSURE REGULATING VALVE
10. PRESSURE SWITCH

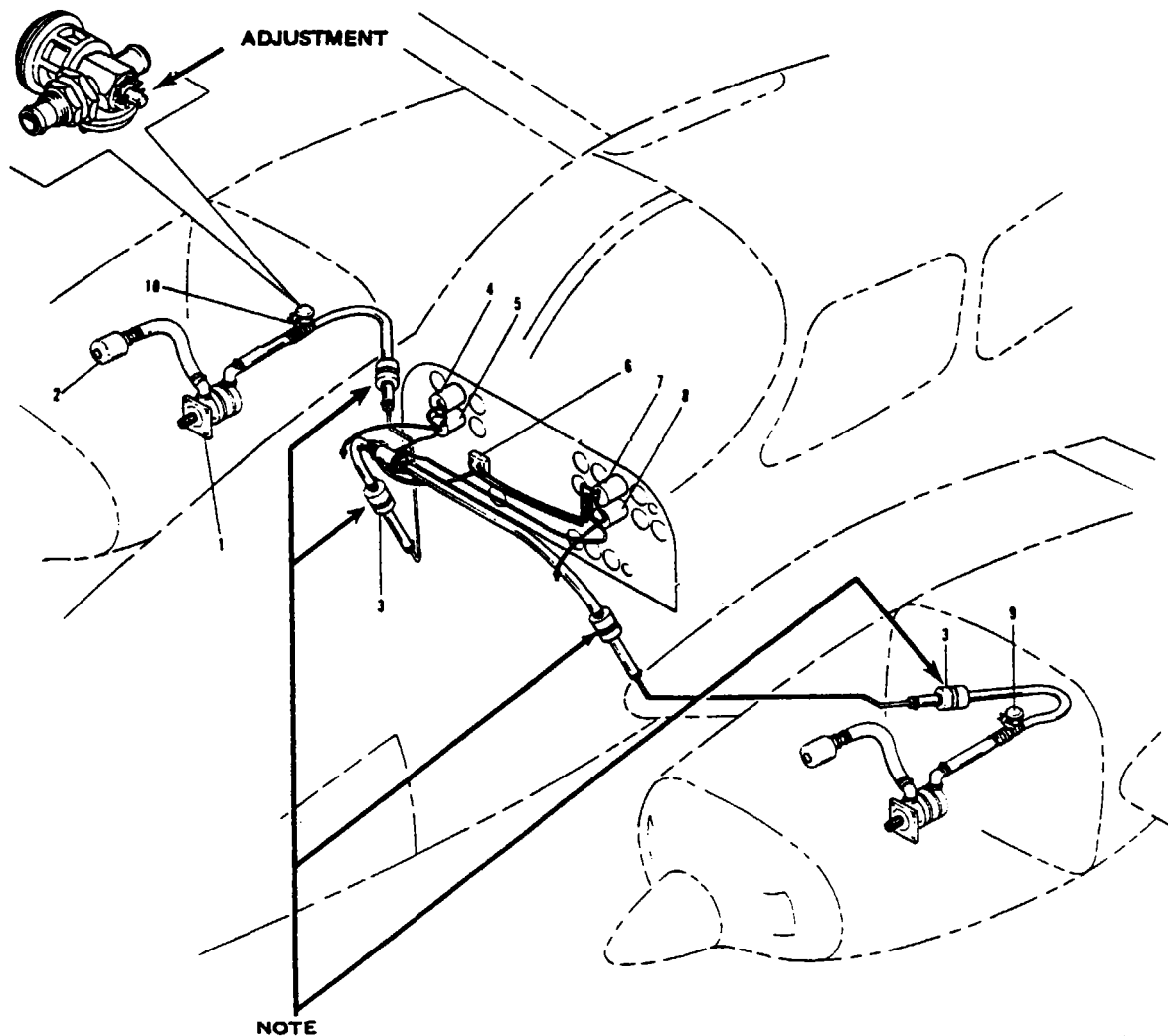

NOTE

INLINE FILTERS (3) MAY BE LOCATED, EITHER BEHIND THE INSTRUMENT PANEL OR THE FIRE WALL. FOR SERVICE INFORMATION REFER TO SECTION XIV, PARAGRAPH 14-43.

Figure 10-1. Gyro Pressure System

3. After settings are made on both engines, check the pressure readings to be sure that it is within limits when both engines are operating at mag check RPM.

c. To adjust the regulator, bend the locking tabs on the adjustment screw and adjust the screw as required to obtain correct gyro pressure.

d. After adjustment is complete, bend tabs to lock screw in place and recheck pressure. Reinstall nacelle cover.

10-13. REMOVAL AND INSTALLATION.

a. Remove the nacelle access cover.

b. Loosen the hose clamps on the regulating valve and disconnect the hoses.

c. Disconnect the two electrical leads.

d. Remove the nut and flat washer securing the regulator to the fire wall and withdraw the regulator.

e. Reinstall the regulator in reverse order of removal.

10-14. PNEUMATIC PUMP.

10-15. GENERAL. The pneumatic pump is a rotary vane, positive displacement dry type pump. The pump is mounted on the accessory section of each engine and rotates counterclockwise on the left engine and clockwise on the right engine. The drive ratio to the crankshaft is 1.545:1.

10-16. TROUBLESHOOTING. (Refer to Table X-I.)

10-17. REMOVAL AND INSTALLATION.

a. Remove the top portion of the engine cowling.

b. Disconnect the two hoses at the pump.

c. Remove the four mounting nuts, lockwashers and plain washers, and withdraw the pump from the engine.

d. Reinstall the pump in reverse order of removal, noting the following:

1. Place gasket in proper position.

CAUTION

The only dry air pump mounting gasket authorized and approved for use on Airborne dry air pump is the Airborne gasket B3-1-2, Piper part number 751 859. Use of any other gasket may result in oil seepage or leakage at the mounting surface.

2. Torque the four mounting nuts to 40-50 inch-pounds.

e. Check hose connections and mounting hardware for security.

10-17a. REPLACING PUMP FITTINGS.

a. The handling procedures for securing the pump while installing or removing fittings are as follows:

1. Use two soft wood blocks in a vise to protect pump from vise jaws.

2. The pump square mounting flange must be held between the wood blocks at right angles to the vise jaws.

3. Use only enough vise pressure to hold pump firmly.

CAUTION

Do not apply vise pressure to outside diameter or overall length of the pump.

PIPER SENECA II SERVICE MANUAL

b. Thread lubricant, if required, should be applied sparingly to the external threads of the fitting only. Use a powdered moly sulfide or graphite in dry form or in an evaporating vehicle, or employ a silicone spray.

CAUTION

Do not use pipe tape, thread dope, hydrocarbon oil or grease, as these can contaminate pump and cause malfunction.

- c. Use the following steps for fitting installation:
1. Secure pump as noted above.
 2. Insert fittings in pump ports and hand tighten firmly.
 3. Using a wrench, tighten each fitting from one-half to two additional turns.

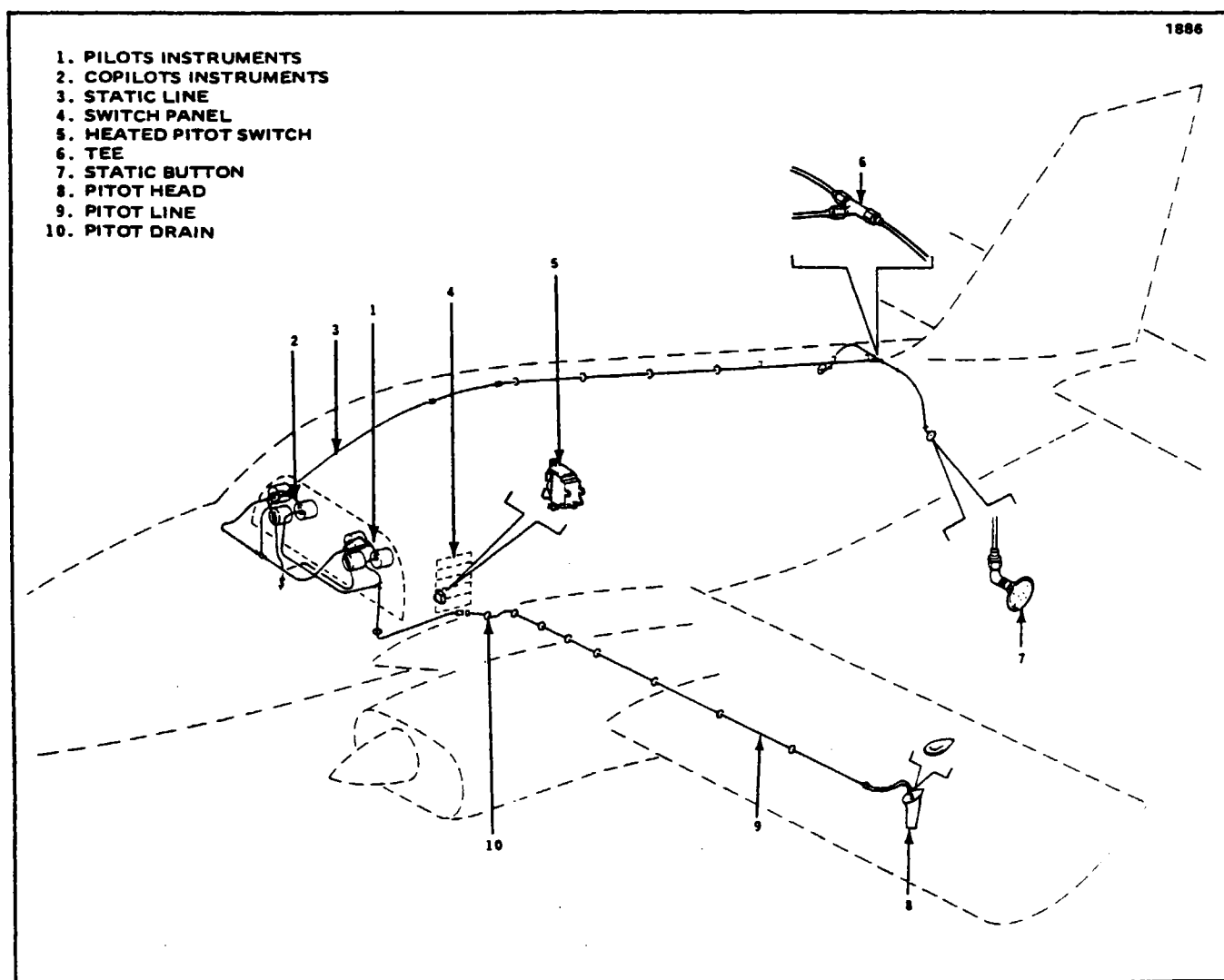

Figure 10-2. Pitot-Static System
(Serial Nos. 34-7570001 to 34-7670136 incl.)

2039

- | | |
|---------------------------------|--------------------------------|
| 1. PILOT'S INSTRUMENTS | 13. ELBOW |
| 2. COPILOT'S INSTRUMENTS | 14. CIRCUIT BREAKER |
| 3. STATIC LINE | 15. ALTERNATE STATIC AIR VALVE |
| 4. SWITCH PANEL | |
| 5. HEATED PITOT SWITCH | |
| 6. TEE | |
| 7. STATIC BUTTON | |
| 8. PITOT HEAD | |
| 9. PITOT LINE | |
| 10. SUMP ASSEMBLY (DRAIN VALVE) | |
| 11. CONNECTOR | |
| 12. GASKET | |

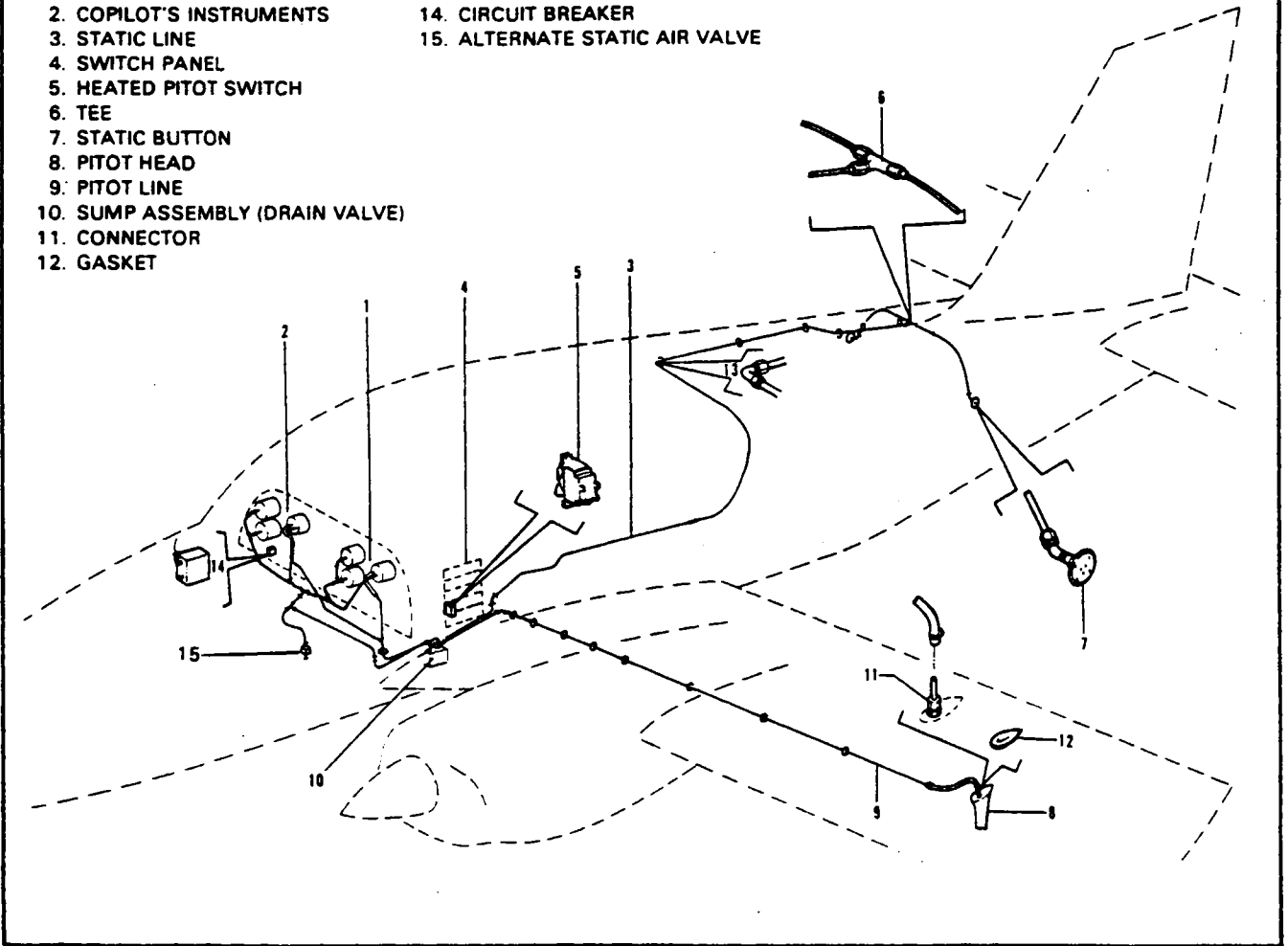
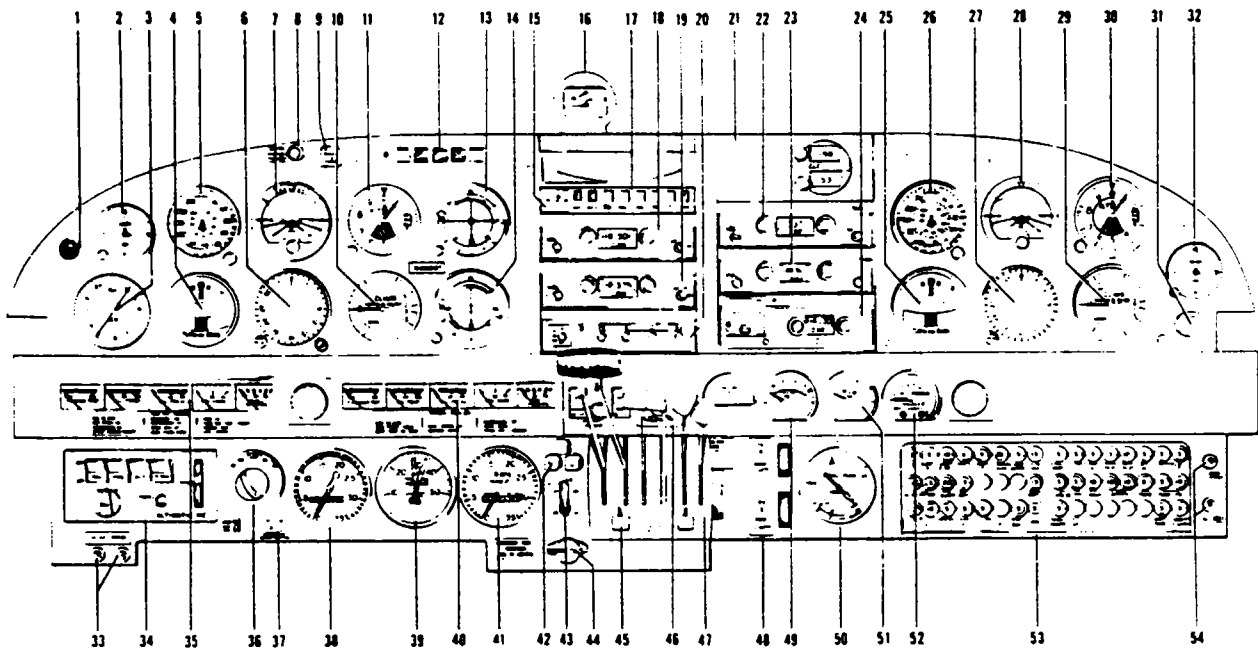

Figure 10-2a. Pitot-Static System
(Serial Nos. 34-7670137 and up)

PIPER SENECA II SERVICE MANUAL

1972



- | | |
|--|--|
| <ol style="list-style-type: none"> 1. STALL WARNING LIGHT 2. CLOCK 3. ADF INDICATOR 4. TURN AND BANK INDICATOR 5. AIRSPEED INDICATOR 6. DIRECTIONAL GYRO 7. ATTITUDE GYRO 8. GLIDE SLOPE COUPLER ENGAGED 9. GEAR IN TRANSIT LIGHT 10. VERTICAL SPEED INDICATOR 11. ALTIMETER 12. ANNUNCIATOR PANEL 13. OMNI AND GLIDE SLOPE INDICATOR 14. OMNI INDICATOR 15. MARKER BEACON 16. COMPASS 17. AUDIO CONTROL PANEL 18. COMMUNICATIONS TRANSCEIVERS (NO. 1) 19. COMMUNICATIONS TRANSCEIVERS (NO. 2) 20. TRANSPONDER 21. R-NAV 22. ADF RECEIVER 23. NAVIGATION RECEIVER 24. DME 25. TURN AND BANK INDICATOR (COPILOT'S) 26. AIRSPEED INDICATOR (COPILOT'S) 27. DIRECTIONAL GYRO (COPILOT'S) | <ol style="list-style-type: none"> 28. ATTITUDE GYRO (COPILOT'S) 29. VERTICAL SPEED INDICATOR (COPILOT'S) 30. ALTIMETER (COPILOT'S) 31. CIGAR LIGHTER 32. CLOCK (COPILOT'S) 33. MIKE AND PHONE JACKS 34. ALTIMATIC III C AUTOPILOT 35. LEFT ENGINE AND FUEL INSTRUMENT CLUSTER 36. OMNI COUPLER 37. PITCH TRIM 38. LEFT ENGINE TACHOMETER 39. DUAL MANIFOLD PRESSURE GAUGE 40. RIGHT ENGINE AND FUEL INSTRUMENT CLUSTER 41. RIGHT ENGINE TACHOMETER 42. LANDING GEAR DOWN LIGHTS 43. LANDING GEAR SELECTOR 44. LANDING GEAR FREE FALL VALVE CONTROL 45. ALTERNATE AIR CONTROL 46. PROP DEICE AMMETER 47. CONTROL QUADRANT 48. RADIO LIGHTS AND PANEL LIGHTS 49. LEFT ENGINE EGT GAUGE 50. FUEL FLOW GAUGE 51. RIGHT ENGINE EGT GAUGE 52. GYRO PRESSURE GAUGE 53. CIRCUIT BREAKER PANEL 54. MIKE AND PHONE JACKS (COPILOT'S) |
|--|--|

Figure 10-3. Instrument Panel

Reissued: 10/11/79

2E18

INSTRUMENTS

10-18. PITOT-STATIC SYSTEMS. Pitot pressure for the airspeed indicator is sensed by the pitot mast mounted under the left wing. Static pressure for the altimeter, vertical speed and airspeed indicators is sensed by two static pressure units, one located on each side of the rear part of the fuselage.

An alternate static source control valve is located below the instrument panel to the right of the power quadrant. If one or more of the pitot-static instruments malfunctions, these pressure systems should be checked for leaks, dirt or water. If moisture is present, the static system can be drained by turning on the alternate static system. The selector valve is located at the low point of the system. Another drain is provided in the lower left front side panel to drain moisture from the pressure line running between the pitot mast and the instrument panel. At any time an instrument, fitting, line, pitot head or static button is disconnected, tests must be performed prior to the next flight. Refer to Advisory Circular 43-13-1A for the testing procedures.

10-19. DIRECTIONAL GYRO.

10-20. GENERAL. The directional gyro is a flight instrument incorporating an air driven gyro stabilized in the vertical plane. The gyro is rotated at high speed by air pressure directed against the gyro buckets produced at the engine driven pneumatic pump. Due to gyroscopic inertia, the spin axis continues to point in the same direction even though the aircraft yaws to the right or left. This relative motion between the gyro and the instrument case is shown on the instrument dial which is similar to a compass card. The dial when set to agree with the airplane magnetic compass provides a positive indication free from swing and turning error. However, the directional gyro has no sense of direction and must be set to the magnetic compass. Since the magnetic compass is subject to errors due to magnetic fields, electric instruments, etc., the directional gyro is only accurate for the heading it has been set for. If the gyro is set on 270°, for instance, and the aircraft is turned to some other heading, there can be a large error between the gyro and the magnetic compass due to the error in compass compensation; this will appear as gyro precession. The gyro should only be checked on the heading on which it was first set; also due to internal friction, spin axis error, air turbulence and airflow, the gyro should be set at least every 15 minutes for accurate operation whether it has drifted or not.

PIPER SENECA II SERVICE MANUAL

10-21. TROUBLESHOOTING.

TABLE X-II. DIRECTIONAL GYRO INDICATOR

Trouble	Cause	Remedy
Excess drift in either direction.	Setting error. Defective instrument. High or low pressure. If pressure is not correct, check for the following: a. Pressure regulator improperly adjusted. b. Incorrect gauge reading. c. Pump failure. d. Line kinked or leaking.	See Par. 10-19. Replace instrument. a. Adjust. b. Replace gauge. c. Repair or replace. d. Check and repair. Check for collapsed inner wall of hose.
Dial spins during turn.	Limits (55° bank) of gimbal exceeded.	Reset gyro in level flight.
Dial spins continuously.	Defective instrument.	Replace instrument.

10-22. REMOVAL AND REPLACEMENT. Refer to Paragraph 10-72 of this section.

10-23. GYRO HORIZON.

10-24. GENERAL. The gyro horizon is essentially an air driven gyroscope rotating in a horizontal plane and is operated by the same principal as the directional gyro. Due to the gyroscopic inertia, the spin axis continues to point in the vertical direction, providing a constant visual reference to the attitude of the airplane relative to pitch and roll axis. A bar across the face of the indicator represents the horizon and aligning the miniature airplane to the horizon bar simulates the alignment of the airplane to the actual horizon. Any deviation simulates the deviation of the airplane from the true horizon. The gyro horizon is marked for different degrees of bank.

10-25. TROUBLESHOOTING.

TABLE X-III. GYRO HORIZON INDICATOR

Trouble	Cause	Remedy
Bar fails to respond.	Insufficient pressure.	Check pump and tubing.
	Filter dirty.	Clean or replace filter.
Bar does not settle.	Insufficient pressure.	Check line and pump. Adjust valve.
	Incorrect instrument.	Check part number.
	Defective instrument.	Replace.
Bar oscillates or shimmies continuously.	Instrument loose in panel.	Tighten mounting screws.
	Pressure too high.	Adjust valve.
	Defective instrument.	Replace instrument.
Instrument does not indicate level flight.	Instrument not set properly.	Loosen screws and level instrument. Trim aircraft.
	Instrument not level in panel.	
	Aircraft out of trim.	
Bar high after 180° turn.	Normal, if it does not exceed 1/16 inch.	
Instrument tumbles in flight.	Low pressure.	Reset regulator.
	Dirty filter.	Clean or replace filter.
	Line to filter restricted.	Replace line.
	Plug missing or loose in instrument.	Replace or tighten plug.
	Bank or Pitch Limits exceeded	

PIPER SENECA II SERVICE MANUAL

10-26. REMOVAL AND REPLACEMENT. Refer to Paragraph 10-72 of this section.

10-27. RATE OF CLIMB INDICATOR.

10-28. GENERAL. The rate of climb indicator measures the rate of change in static pressure when the airplane is climbing or descending. By means of a pointer and dial, this instrument will indicate the rate of ascent or descent of the airplane in feet per minute. Due to the lag of the instrument, the aircraft will be climbing or descending before the instrument gives the correct rate. The instrument will continue to read after the aircraft has assumed level flight. In rough air this should not be considered a malfunction.

10-29. TROUBLESHOOTING.

TABLE X-IV. RATE OF CLIMB INDICATOR

Trouble	Cause	Remedy
Pointer does not set on zero.	Aging of diaphragm.	Reset pointer to zero by means of setting screw. Tap instrument while resetting.
Pointer fails to respond.	Obstruction in static line. Pitot-Static head frozen over. Water in static line. Obstruction in pitot head.	Disconnect all instruments connected to the static line. Clear line. Check individual instruments for obstruction in lines. Clean lines and head.
Pointer oscillates.	Leaks in static lines. Defective mechanism.	Disconnect all instruments connected to the static line. Check individual instruments for leaks. Reconnect instruments to static line and test installation for leaks. Replace instrument.
Rate of climb indicates when aircraft is banked.	Water in static line.	Disconnect static lines and blow out lines from cockpit out to pitot head.

TABLE X-IV. RATE OF CLIMB INDICATOR (cont)

Trouble	Cause	Remedy
Pointer has to be set before every flight.	Temperature compensator inoperative.	Replace instrument.
Pointer cannot be reset to zero.	Diaphragm distorted.	Replace instrument.
Instrument reads very low during climb or descent.	Case of instrument or line broken or leaking.	Replace instrument.

10-30. REMOVAL AND REPLACEMENT. Refer to Paragraph 10-72 of this section.

10-31. SENSITIVE ALTIMETER.

10-32. GENERAL. The altimeter indicates altitude in feet above sea level. The indicator has three pointers and a dial scale; the long pointer is read in hundredths of feet; the middle pointer in thousandths of feet, and the short pointer in ten thousandths of feet. A barometric pressure window is located on the right side of the indicator dial and is set by the knob located on the lower left corner of the instrument. The altimeter consists of a sealed diaphragm that is connected to the pointers through a mechanical linkage. The instrument case is vented to the static air system and as static air pressure decreases, the diaphragm expands, causing the pointers to move through the mechanical linkage to indicate a higher altitude.

10-33. TROUBLESHOOTING.

TABLE X-V. ALTIMETER

Trouble	Cause	Remedy
Excessive scale error.	Improper calibration adjustment.	Replace instrument.
Excessive pointer oscillation.	Defective mechanism.	Replace instrument.
High or low reading.	Improper venting.	Eliminate leak in static pressure system and check alignment of sensor.
Setting knob is hard to turn.	Wrong lubrication or lack of lubrication.	Replace instrument.

PIPER SENECA II SERVICE MANUAL

TABLE X-V. ALTIMETER (cont)

Trouble	Cause	Remedy
Altimeter sticks at altitude or does not change with change of altitude.	Water or restriction in static line.	Remove static lines from all instruments, blow line clear from cockpit to sensor.
Altimeter changes reading as aircraft is banked.	Water in static line.	Remove static lines from all instruments, and blow line clear from cockpit to sensor.
Altimeter requires resetting frequently.	Temperature compensator inoperative.	Change instrument.
Inner reference marker fails to move when setting knob is rotated.	Out of engagement.	Replace instrument.
Setting knob set screw loose or missing.	Not tight when altimeter was reset.	Tighten instrument screw, if loose. Replace screw, if missing.
Cracked or loose cover glass.	Case gasket hardened.	Replace or repair instrument.
Dull or discolored markings.	Age.	Replace or repair instrument.
Barometric scale and reference markers out of synchronism with pointers.	Drift in mechanism.	Reset pointers, per AC 43.13-1.

NOTE

When any connections in the static system are opened for checking, system must be rechecked per Part FAR 23.1325.

10-34. REMOVAL AND REPLACEMENT. Refer to Paragraph 10-72 of this section.

10-35. AIRSPEED INDICATOR.

10-36. GENERAL. The airspeed indicator provides a means of indicating the speed of the airplane passing through the air. The airspeed indication depends on the differential pressure between pitot air pressure and static air pressure. This instrument has the diaphragm vented to the pitot air source and the case is vented to the static air system. As the airplane increases speed, the pitot air pressure increases, causing the diaphragm to expand. A mechanical linkage picks up this motion and moves the instrument pointer to the indicated speed. The instrument dial is calibrated in knots and miles per hour, and also has the necessary operating range markings for safe operation of the airplane.

10-37. TROUBLESHOOTING.

TABLE X-VI. AIRSPEED TUBES AND INDICATOR

Trouble	Cause	Remedy
Pointers of static instruments do not indicate properly.	Leak in instrument case or in static lines.	Check for leak and seal.
Pointer of instrument oscillates.	Defective mechanism.	Replace instrument.
Instrument reads high.	Pointer not on zero.	Replace instrument.
	Leaking static system.	Find leak and correct.
Instrument reads low.	Pointer not on zero.	Replace instrument.
	Leaking static system.	Find leak and correct.
	Pitot-Static head not aligned correctly.	Realign pitot-static head
Airspeed changes as aircraft is banked.	Water in static line.	Remove lines from static instruments and blow out lines from cockpit to pitot-static head.

NOTE

When any connections in static system are opened for checking, system must be checked per FAR 23.1325.

10-38. REMOVAL AND REPLACEMENT. Refer to Paragraph 10-72 of this section.

10-39. MAGNETIC COMPASS.

10-40. GENERAL. The magnetic compass is a self-contained instrument. This instrument has an individual light which is connected to the instrument lighting circuit. The compass correction card is located in the card holder mounted on the instrument. The compass should be swung whenever instruments or radios are changed and at least once a year.

10-41. ADJUSTMENT OF COMPASS. Before attempting to compensate compass, every effort should be made to place the aircraft in simulated flight conditions; check to see that the doors are closed, flaps in retracted position, engines running, throttles set at cruise position and aircraft in level flight attitude. Aircraft master switch, alternator, and radios should be on. All other cockpit controlled electrical switches should be in the off position.

- a. Set adjustment screws of compensator on zero. Zero position of adjusting screws is when the dot of the screw is lined up with the dot of the frame.
- b. Head aircraft on a magnetic North heading. Adjust N-S adjustment screw until compass reads exactly North.
- c. Head aircraft on a magnetic East heading and do the same as Step b, adjusting E-W adjusting screw.
- d. Head aircraft on a magnetic South heading and note resulting South error. Adjust N-S adjusting screw until one-half of this error has been compensated. No compensation adjustments shall be made with the combustion heater operating.
- e. Head aircraft on magnetic West and do same as Step d, adjusting E-W adjustment screw.
- f. Head aircraft in successive magnetic 30° degree headings and record compass readings on appropriate deviation card. Deviations must not exceed $\pm 10^\circ$ on any heading. An additional deviation card will have to be made out for aircraft with combustion heater installed. This second deviation card shall be accomplished under the above conditions, except the combustion heater shall be operating.

10-42. TROUBLESHOOTING.

TABLE X-VII. MAGNETIC COMPASS

Trouble	Cause	Remedy
Excessive card error.	Compass not properly compensated.	Compensate instrument. (Refer to Para. 10-41)
	External magnetic interference.	Locate magnetic interference and eliminate if possible.
Excessive card oscillation.	Insufficient liquid.	Replace or repair instrument.
Card sluggish.	Weak card magnet.	Replace or repair instrument
	Excessive pivot friction or broken jewel.	Replace or repair instrument.

2F3

INTENTIONALLY LEFT BLANK

TABLE X-VII. MAGNETIC COMPASS (cont.)

Trouble	Cause	Remedy
Liquid leakage.	Loose bezel screws. Broken cover glass. Defective sealing gaskets.	Replace or repair instrument. Replace or repair instrument. Replace or repair instrument.
Discolored markings.	Age.	Replace or repair instrument.
Defective light.	Burned out lamp or broken circuit.	Check lamp or continuity of wiring.
Card sticks.	Altitude compensating diaphragm collapsed.	Replace or repair instrument.
Card does not move when compensating screws are turned.	The gears that turn compensating magnets may be stripped.	Replace or repair instrument.
Compass swings erratically when radio transmitter is keyed.	Normal.	

10-43. MANIFOLD PRESSURE GAUGE SYSTEM.

10-44. GENERAL. The dual manifold pressure gauge is a vapor proof, absolute pressure type instrument calibrated from 10 to 50 inches of mercury. Incorporated in the gauge are switches that complete the annunciator panel circuit whenever engine manifold pressure exceeds 39.5 inches of mercury. The manifold pressure lines have drain valves located behind and below the fuel manifold pressure gauge. This allows any moisture which may have collected from condensation to be pulled into the engines. This is accomplished by depressing the two valves for 5 seconds while operating the engines at 1000 RPM.

NOTE

Do not depress the valves when manifold pressure exceeds 2.5 inches Hg.

10-45. TROUBLESHOOTING.

TABLE X-VIII. MANIFOLD PRESSURE INDICATOR

Trouble	Cause	Remedy
Excessive error at existing barometric pressure.	Pointer shifted.	Replace instrument.
Excessive error when engine is running.	Line leaking.	Tighten line connections.
Sluggish or jerky pointer movement.	Defective instrument.	Replace instrument.
Dull or discolored marking.	Age.	Replace instrument.
Incorrect reading.	Moisture or oil in line.	Depress line valves and/or disconnect lines at instrument and blow out.

10-46. REMOVAL AND REPLACEMENT. Refer to Paragraph 10-72 of this section.

10-47. TACHOMETER INDICATOR.

10-48. GENERAL. Each tachometer is connected to the engine accessory cover by a flexible cable and provides an indication of crankshaft speed in revolutions per minute. The instrument has a recording mechanism for recording the time that the engine is in actual operation. The right-hand tachometer has a reversing drive to correct for the counter rotation of the right-hand engine.

10-49. TROUBLESHOOTING.

PIPER SENECA II SERVICE MANUAL

TABLE X-IX. TACHOMETER

Trouble	Cause	Remedy
No reading on indicator, either permanent or intermittent.	Broken drive cable.	Replace cable.
	Loose cable connections.	Tighten cable.
Pointer oscillates excessively.	Rough spot on, or sharp bend in cable.	Repair or replace.
	Excessive friction in instrument.	Replace instrument.
Indicator changes in climb.	Excessive clearance in speed cup.	Replace instrument.
Pointer goes all the way to stop, more noticeable in cold weather.	Excessive lubricant in instruments.	Replace instruments.
Pointer jumps at idle.	Speed cup hitting rotating magnet.	Replace instrument.
Tachometer cable breaks.	Cable bent too sharply.	Reroute cable, replace shaft.

10-50. REMOVAL AND REPLACEMENT. Refer to Paragraph 10-72 of this section.

10-51. ENGINE OIL PRESSURE GAUGE.

10-52. GENERAL. The oil pressure gauge is mounted in the cluster on the instrument panel. This gauge will indicate the amount of oil pressure available at the pressurized engine oil passage in psi.

10-53. TROUBLESHOOTING.

TABLE X-X. ENGINE OIL PRESSURE GAUGE

Trouble	Cause	Remedy
Excessive error at zero.	Pointer loose on shaft. Overpressure or seasoning of bourdon tube.	Replace instrument.
Excessive scale error.	Improper calibration adjustment.	Replace instrument.
Excessive pointer oscillation.	Air in line or rough engine relief.	Disconnect line and fill with light oil. Check for leaks. If trouble persists, clean and adjust relief valve.
Sluggish operation of pointer or pressure fails to build up. NOTE Gauge will take longer to indicate in cold weather.	Engine relief valve open. Line restriction to instrument. Loss of oil in engine or other engine failure.	Clean and check. Clean and check. Shut down engine refer to Table VIII-III.

10-54. REMOVAL AND REPLACEMENT. Refer to Paragraph 10-78 of this section.

PIPER SENECA II SERVICE MANUAL

10-55. ELECTRICAL INSTRUMENTS.

10-56. TURN AND BANK INDICATOR.

10-57. GENERAL. The turn and bank indicator is an electrical instrument. The turn portion of the indicator is driven by a permanent magnet D.C. governor controlled gyro motor. The pointer is designed to deflect in the direction of turn at a rate proportional to the rate of aircraft turn. The bank portion of the indicator is a ball sealed in a curved glass tube filled with damping fluid. In an improperly coordinated turn the ball is forced from the center of the tube thus indicating error.

10-58. TROUBLESHOOTING.

TABLE X-XI. TURN AND BANK INDICATOR

Trouble	Cause	Remedy
Instrument will not operate.	No power to instrument. Instrument malfunction. Foreign matter lodged in instrument.	Reset circuit breaker. Check circuit and repair. Repair instrument. Replace instrument.
Incorrect sensitivity.	Out of calibration.	Replace instrument.
Incorrect turn rate.	Out of calibration.	Replace instrument.
Ball sticky.	Flat spot on ball.	Replace instrument.
Ball not in center when aircraft is correctly trimmed.	Instrument not level in panel.	Level instrument.

10-59. REMOVAL AND REPLACEMENT. Refer to Paragraph 10-72 of this section.

10-60. FUEL QUANTITY INDICATOR.

10-61. GENERAL. The two fuel quantity gauges are mounted in the clusters on the instrument panel. These instruments are calibrated in U.S. gallons. Two transmitter units are installed in each fuel tank. Each unit contains a resistance strip and a movable control arm. The position of this arm is controlled by a float and this position is transmitted electrically to the indicator gauge to show the amount of fuel in the tank. The two transmitters in each tank are connected in series; the outboard sender must be insulated from airframe ground.

10-62. TROUBLESHOOTING.

TABLE X-XII. FUEL QUANTITY INDICATORS

Trouble	Cause	Remedy
Fuel gauge fails to indicate.	Broken wiring.	Check and repair.
	Gauge not operating.	Replace.
Fuel gauge indicates empty when tanks are full.	Incomplete ground.	Check ground connections at inboard transmitter in wings.
Fuel gauge indicates full with tanks empty.	Partial short to ground.	Check wiring.
	Float arm stuck.	Replace fuel transmitter.
Fuel gauge indicates incorrectly.	Intermittent electrical connection.	Check ground at inboard transmitter and electrical connections.
	Faulty transmitter.	Replace fuel transmitter.

10-63. REMOVAL AND REPLACEMENT. Refer to Paragraph 10-74 of this section.

10-64. OIL TEMPERATURE INDICATOR.

10-65. GENERAL. The oil temperature indicator is mounted in the instrument cluster on the instrument panel. This instrument will provide a temperature indication of the engine oil in degrees Fahrenheit. The instrument has a temperature bulb located on the left side of the engine.

PIPER SENECA II SERVICE MANUAL

10-66. TROUBLESHOOTING.

TABLE X-XIII. OIL TEMPERATURE INDICATORS

Trouble	Cause	Remedy
Instrument fails to show any reading.	Broken or damaged bulb. Wiring open.	Check engine unit and wiring to instrument.
Excessive error.	Improper calibration adjustment.	Replace instrument.
Pointer fails to move as engine is warmed up.	Broken or damaged bulb or open wiring.	Check engine unit and wiring.
Dull or discolored marking.	Age.	Replace instrument.

10-67. REMOVAL AND REPLACEMENT. Refer to Paragraph 10-74 of this section.

10-68. AMMETER.

10-69. GENERAL. The ammeters are mounted in the instrument cluster. This instrument measures the current going into the entire electrical system including the battery charging demand.

10-70. TROUBLESHOOTING. Refer to Section XI (Alternator Section).

10-71. REMOVAL AND REPLACEMENT. Refer to Paragraph 10-74 of this section.

10-72. REMOVAL AND REPLACEMENT OF FACE MOUNTED INSTRUMENTS.

10-73. GENERAL. Since all instruments are mounted in a similar manner, a description of a typical removal and installation is provided as a guide for the removal and installation of the instruments. Special care should be taken when any operation pertaining to the instruments is performed.

a. Remove the face panel.

b. With the face panel removed, the mounting screws for the individual instruments will be exposed.

Remove the connections to the instrument prior to removing the mounting screws of the instrument to be removed.

NOTE

Tag instrument connections for ease of installation.

c. Installation of the instruments will be in the reverse given for removal (Refer to step d. for gyro fitting installation).

CAUTION

DO NOT use thread lube on fittings or in ports of gyros. The use of thread lube can cause contamination which shortens the life expectancy of the gyro and can cause premature failures. Any evidence of thread lube will create a **WARRANTY VOID CONDITION**. Make sure that all air lines are clean and free of oil, grease, pipe compound or any foreign material and/or residue before connecting lines to gyro.

d. The use of 3M-48x¼ teflon pipe thread sealant tape on gyro fitting threads is recommended and should be installed in the following manner.

1. Carefully lay teflon tape on the threads, allowing one to two lead-in threads to be visible from the end of the fitting. Hold in place and wrap in the direction of the threads, so tape will remain tight when fitting is installed.

2. Apply sufficient tension while winding, to assure that the tape forms into thread grooves. One full wrap plus ½" overlap is sufficient.

3. After wrap is complete, maintain tension and tear tape by pulling in direction of wrap. The ragged end is the key to the tape staying in place. (If sheared or cut tape may loosen.)

4. Press tape well into threads.

5. Screw fitting into port being careful not to exceed torque requirements as noted on decal located on cover of gyro.

e. After the installation is completed and before replacing the instrument face panel, check all components for security and clearance of the control column.

INTENTIONALLY LEFT BLANK

10-74. REMOVAL AND REPLACEMENT OF CLUSTER MOUNTED INSTRUMENTS.

10-75. GENERAL.

- a. Remove the face panel by springing the plastic material from the channels.
- b. With the face panel held in a vertical position, the screws securing the clusters are accessible. Remove the screws and the lens of the cluster to be repaired.
- c. Remove the plastic light seals adjacent to the instrument to be replaced.
- d. Remove the wires or tube to the instrument. Tag wires so they can be returned to the same terminal on the replacement instrument.
- e. Remove nuts and insulating washers on electrical instruments; then move instrument aft. Mechanical instruments have only one large nut and lock washer.
- f. Replace instrument in the reverse order of removal. Check all mountings and connections for security.

10-76. EXHAUST GAS TEMPERATURE GAUGE.

10-77. GENERAL. This instrument, which is commonly referred to as EGT, is used to aid the pilot in setting the economical fuel-air mixture for cruising flight at a power setting of 75% or less. It is a sensing device to monitor the temperature of exhaust gases leaving the engine cylinders. If it is found defective after checking with troubleshooting chart, it should be replaced. If the leads to the gauge are defective in any way, they must be replaced. When replacing leads, it is necessary to use the same type and length of wire because the resistance of the leads is critical for the proper operation of this gauge.

10-78. REMOVAL OF EGT PROBE AND GAUGE.

- a. Disconnect wires from the EGT gauge at the instrument panel.
- b. Remove four bolts which secure the gauge to the instrument panel and remove the gauge.
- c. Remove wires from the wire harness going to the engine.
- d. Loosen the nut which secures the EGT probe to the exhaust transition area of the exhaust system and remove the probe.

10-78a. CLEANING AND INSPECTION. Unless mechanical damage such as broken glass, bent or broken pointer, or broken case, the following checks should be performed before removing the instrument:

- a. Remove probe from exhaust transition area and check for broken weld (at tip end) or burnt off end. Measured resistance of probe should be .8 ohms. Clean the connections with steel wool before reassembly.
- b. Disconnect lead wires at instrument and measure length and diameter. Resistance with lead wires connected to probe should be 3.3 ohms. Clean connections with steel wool before reassembly.
- c. With leads connected to instrument, heat probe with propane torch to dull red. The meter should read up to the fourth graduation or approximately 1500°F. Before making this check, make sure that the adjustment screw, which is located in the rear of the instrument case, is in the center of its travel. If this screw has been turned to either end of full travel, it will shut the instrument off and no indication will be shown on the pointer. If meter still does not read, replace it.

CAUTION

Do not connect ohmmeter across meter; it will burn out the movement of the meter.

10-78b. INSTALLATION OF EGT PROBE AND GAUGE.

- a. Lubricate the probe fitting with Fel-Pro C5-A Anti-Seize Lube PT #51005 and install the probe into the hole in the transition area of the exhaust system and secure with locknut.
- b. Route the thermocouple wires along with the existing wire harness to the instrument panel.
- c. Install the EGT gauge into the instrument panel and secure with four bolts.
- d. Connect the thermocouple wires to the rear of the EGT gauge.

10-79. TROUBLESHOOTING.

TABLE X-XIV. EXHAUST GAS TEMPERATURE GAUGE

Trouble	Cause	Remedy
Gauge inoperative.	Master Switch OFF. Circuit Breaker OUT. Defective gauge, probe or wiring. Adjusting potentiometer turned off scale.	Turn switch ON. Push breaker IN. Check probe and lead wires for chafing, breaks or shorting between wires and/or metal structure. Reset potentiometer.
Fluctuating reading.	Loose, frayed or broken electrical leads or faulty connections.	Clean and tighten connections. Repair or replace defective leads.

10-80. CYLINDER HEAD TEMPERATURE GAUGE.

10-81. GENERAL. The cylinder head temperature gauge is in the instrument cluster, located on the instrument panel. This instrument measures the cylinder head temperature using a sender located in a cylinder head. The cylinder head used is determined by the engine manufacturer. This gauge is an electrical instrument and is wired through the instrument's circuit breaker.

PIPER SENECA II SERVICE MANUAL

10-82. TROUBLESHOOTING.

TABLE X-XV. CYLINDER HEAD TEMPERATURE GAUGE

Trouble	Cause	Remedy
Instrument shows no indication.	Engine is cold.	Warm up engine.
	Power supply wire open.	Repair wire.
	Defective sender.	Replace sender.
	Defective instrument.	Replace instrument.
	Open circuit breaker.	Troubleshoot for fault.
Instrument goes all the way to upper stop.	Wire grounded between sender and gauge.	Repair wire.
	Defective sender.	Replace sender.

10-83. REMOVAL AND REPLACEMENT. Refer to Paragraph 10-72 of this section.

10-84. FUEL FLOW GAUGE.

10-85. GENERAL. The fuel flow gauge is a non-electric differential pressure gauge mounted in the bottom of the instrument panel.

This instrument measures flow by reading the pressure drop across a fixed orifice located in the fuel divider. With a constant fuel pressure being supplied by the engine driven pump and putting a fixed orifice in the fuel divider head and then measuring the pressure drop downstream of the orifice against manifold pressure, the resultant pressure can be calibrated in gallons per hour flow.

10-86. TROUBLESHOOTING.

TABLE X-XVI. FUEL FLOW GAUGE

Trouble	Cause	Remedy
Pointer oscillates.	Air in fuel line.	Purge line.
Gauge reads low at altitude.	Vent line restricted.	Check line and fittings.
Pointer does not return to zero.	Fuel in diaphragm of gauge.	Replace gauge.

PIPER SENECA II SERVICE MANUAL

10-87. REMOVAL AND REPLACEMENT. Refer to Paragraph 10-72 of this section.

10-88. PIPER AUTOCONTROL SYSTEM. (See AutoControl Service Manual).

TABLE X-XVII. INSTRUMENT MARKINGS

Fuel Flow:	
Green Arc (Normal Operating Range)	0 to 20.0 GPH
Red Line	3.5 and 20.0 PSI
Manifold Pressure:	
Radial Red Line	10 in. Hg. and 40 in. Hg.
Tachometer:	
Green Arc (Normal Operating Range)	500 RPM to 2000 RPM and 2200 RPM to 2575 RPM
Radial Red Line (Maximum)	2575 RPM
Cylinder Head Temperature:	
Green Arc (Normal Operating Range)	360 to 460°F
Radial Red Line (Never Exceed)	460°F
Oil Pressure:	
Green Arc (Normal Operating Range)	30 PSI to 80 PSI
Yellow Arc (Caution)	10 to 30 PSI and 80 to 100 PSI
Radial Red Line:	
Minimum	10 PSI
Maximum	100 PSI
Oil Temperature:	
Green Arc (Normal Operating Range)	75 to 240°F
Radial Red Line (Never Exceed)	240°F
Airspeed Indicator:	
Green Arc (Normal Operating Range)	76 MPH to 190 MPH
Yellow Arc (Caution Range - Smooth Air)	190 MPH to 224 MPH
White Arc (Flaps Extended Range)	69 MPH to 125 MPH
Radial Red Line (Never Exceed - Smooth Air)	224 MPH
Radial Red Line (Minimum Control Speed - Single Engine)	80 MPH
Radial Blue Line (Best R/C Speed Single Engine)	105 MPH

10-89. ANNUNCIATOR PANEL.

10-90. GENERAL. The annunciator panel is a light cluster mounted in the upper left instrument panel that provides a visual indication of individual system malfunctions. A press-to-test switch on the left side of the annunciator will illuminate the entire display to check the condition of each display lamp when the engine is running. The lamps will light when the engine is not running with the master switch ON. Sensors located in the individual systems monitored activate to complete the annunciator circuit whenever a system malfunctions.

10-91. TROUBLESHOOTING. (Refer to Section XI.)

10-92. REMOVAL AND REPLACEMENT. (Refer to Paragraph 10-72.)

SECTION XI

ELECTRICAL SYSTEM

Paragraph	Aerofiche Grid No.
11-1. Introduction	2F20
11-2. Description	2F20
11-3. Troubleshooting	2F20
11-4. Alternator System	2F20
11-5. Alternator and Components	2F23
11-6. Description of Alternator	2F23
11-7. Checking Alternator System	2F24
11-8. Service Procedures	2G1
11-9. Overhaul of Alternator	2G1
11-10. Disassembly of Alternator	2G2
11-11. Inspection and Testing of Components	2G4
11-12. Assembly of Alternator	2G5
11-13. Testing Alternator	2G6
11-14. Precautions	2G7
11-15. Alternator Service Test Specifications	2G8
11-16. Alternator Nomenclature	2G9
11-17. Voltage Regulator	2G9
11-18. Regulator Components	2G9
11-19. Operation of Regulator	2G9
11-20. Balancing Circuit Operation	2G10
11-21. Preparation for Testing	2G11
11-22. Testing Regulator	2G12
11-23. Adjusting Regulator	2G13
11-24. Overvoltage Relay	2G14
11-25. Checking Overvoltage Relay	2G14
11-26. Starting Motors	2G16
11-27. Description	2G16
11-28. Operation	2G16
11-29. Maintenance	2G16
11-30. Overhaul	2G17
11-31. Removal	2G17
11-32. Disassembly	2G17
11-33. Brushes	2G18
11-34. Armature	2G18
11-35. Field Coils	2G18
11-36. Brush Holders	2G19
11-37. Assembly	2G19
11-38. Bench Tests	2G20
11-39. Starting Motor Control Circuit	2G20
11-40. Starting Motor Service Test Specifications	2G21

Revised: 8/10/80

Paragraph	Aerofiche Grid No.
11-41. Battery	2G21
11-42. Servicing Battery	2G21
11-43. Removal of Battery	2G21
11-44. Installation of Battery	2G22
11-45. Charging Battery	2G23
11-46. Battery Box Corrosion Prevention	2G23
11-47. Starting Through External Power Receptacle With Airplane's Battery Nearly Depleted	2G23
11-48. Landing and Taxi Lights	2G24
11-49. Removal of Landing and Taxi Lights	2G24
11-50. Installation of Landing and Taxi Lights	2G24
11-51. Stall Warning System	2H1
11-52. Removal of Lift Detector	2H3
11-53. Installation of Lift Detector	2H3
11-54. Navigation Lights	2H3
11-55. Removal of Wing Navigation Light	2H3
11-56. Installation of Wing Navigation Light	2H3
11-57. Removal of Tail Navigation Light	2H3
11-58. Installation of Tail Navigation Light	2H3
11-58a. Anti-Collision Lights	2H3
11-59. Removal of Lamp in Anti-Collision Wing Tip Strobe Light	2H4
11-60. Installation of Lamp in Anti-Collision Wing Tip Strobe Light	2H4
11-61. Removal of Lamp in Anti-Collision Light	2H4
11-62. Troubleshooting Procedure for Anti-Collision and Wing Tip Strobe Light Systems	2H4
11-63. Installation of Anti-Collision Light	2H5
11-63a. Reading Lights	2H5
11-64. Removal of Lamp in Overhead Reading Lights	2H5
11-65. Installation of Lamp in Overhead Reading Lights	2H5
11-66. Instrument and Panel Lights	2H6
11-67. Removal of Dimmer Control Assembly	2H6
11-68. Installation of Dimmer Control Assembly	2H6
11-69. Annunciator Panel	2H6
11-70. Description	2H6
11-71. Annunciator Lights Test	2H7
11-72. Troubleshooting	2H7

PIPER SENECA II SERVICE MANUAL

TABLE XI-1. INDEX - ELECTRICAL SYSTEMS SCHEMATICS

FIGURE NO.	SCHEMATIC	GRID NO.
ANNUNCIATOR SYSTEMS		
11-35	Annunciator Panel	219
COMFORT SYSTEM		
11-32b	Cigar Lighter	217
DEICE SYSTEMS		
11-40	Defroster	2112
11-32b	Pitot Heat	217
11-42	Stall Warning Sensor Heaters	2113
ELECTRICAL POWER SYSTEMS		
Alternators External Power (Left Right)		
11-23	S N: 34-7570001 to 7570337	2H24
11-24	S N: 34-7670001 to 7670393	211
11-25	S N: 34-7770001 and up	212
Radio Bus Power		
11-33	S N: 34-7570001 to 7570337	218
11-33a	S N: 34-7670001 to 8070001	218
11-33b	S N: 34-8070002 and up	218
ENGINE SYSTEMS		
Engine Gauges		
11-29	Early Models	216
11-30	Later Models	216
11-37	Magnetos	2111
11-26	Starters	213
ENVIRONMENTAL SYSTEMS		
11-49	Air Conditioning	2117
11-40	Heater	2112
11-38	Ventilation - Air Blower	2111
FUEL SYSTEMS		
11-45	Fuel Pumps - Electric (Left Right)	2115
11-43	Fuel Pumps - Auxiliary Electric (Left Right) S N: 34-7670057 to 7670097 (Piper Kit No. 760 926V)	2114
11-44	S N: 34-7670098 and up	2114

PIPER SENECA II SERVICE MANUAL

TABLE XI-I. INDEX - ELECTRICAL SYSTEMS SCHEMATICS (cont.)

FIGURE NO.	SCHEMATIC	GRID NO.
INDICATORS		
11-47	Clock Hour Meter	2116
	Engine Gauges	
11-29	Early Models	216
11-30	Later Models	216
11-46	Turn and Bank Pictorial Rate	2115
11-52	Turn and Bank Pictorial Rate Alternate	2119
LANDING GEAR SYSTEM		
11-27	Landing Gear	214
LIGHTING SYSTEMS - EXTERNAL		
11-32	Anti-Collision - (Strobe-Fin)	217
11-32a	Anti-Collision - (Strobe-Wing and Fin)	217
11-31	Landing Lights	217
11-39	Position Lights	2111
11-53	Tail Flood (Logo) Optional	2119
LIGHTING SYSTEMS - INTERNAL		
	Baggage	
11-34	S N: 34-7570001 and up	219
11-51	S N: 34-7970105 and up	2118
	Courtesy Lighting (Optional)	
11-50	S N: 34-7970105 and up	2118
11-28	Panel Lighting	215
	Reading	
11-48	S N: 34-7570001 to 7770441	2116
11-34	S N: 34-7570001 and up	219
WARNING SYSTEMS		
	Annunciator - (See Annunciator System)	
11-40	Heater Overheat Warning	2112
11-27	Landing Gear - Warning Light & Horn	214
11-41	Stall Warning	2113

Revised: 11/12/82

SECTION XI

ELECTRICAL SYSTEM

11-1. INTRODUCTION. This section contains instructions and schematics for correcting difficulties which may arise in the operation of the electrical system.

The instructions are organized so the mechanic can refer to: Description and Principles of Operation, for a basic understanding of the various electrical systems; Troubleshooting, for a methodical approach in locating the difficulty; Corrective Maintenance, for removal, repair and installation of components; and Adjustments and Tests for operation of the repaired system. Schematics for the individual systems are located at the end of this section. For information concerning electronic equipment, refer to Section XII, Electronics.

11-2. DESCRIPTION. Electrical power is supplied by a 14-volt, direct current, negative ground electrical system. A 12-volt, 35 ampere hour battery is incorporated in the system to furnish power for starting and as a reserve power source in case of alternator failure; it is located in the nose section of the airplane.

The electrical generating system consists of two engine driven 65 ampere alternators. Two solid state regulators maintain effective alternator load sharing while regulating the system bus voltage at 14.0-volts. Also, incorporated in the system are overvoltage relays; one for each alternator circuit which prevents damage to electrical and avionic equipment in case of regulator malfunction. A warning light on the annunciator panel will illuminate if either alternator fails to produce current, accompanied by a zero indication on the individual ammeter. The loads from the electrical bus system are protected by manual reset type circuit breakers mounted on the lower right-hand instrument panel.

11-3. TROUBLESHOOTING. Troubles peculiar to the electrical system are listed in Table XI-V at the back of this section, along with their probable causes and suggested remedies. The wiring diagrams included at the end of this section will give a physical breakdown of the different electrical circuits used in this airplane.

After the trouble has been corrected, check the entire electrical system for security and operation of its components.

11-4. ALTERNATOR SYSTEM. The alternators are mounted on the accessory case of each engine. Many advantages both in operation and maintenance are derived from this system.

The alternators have no armature or commutator and only a small pair of carbon brushes which make contact with a pair of copper slip rings. The rotating member of the alternator, known as the rotor, is actually the field windings. The rotor draws only 1/20th of the current output. Therefore, there is very little friction and negligible wear and heat in this area. The alternating current is converted to direct current by diodes pressed into the end bell housing of the alternator. The diodes are highly reliable solid state devices but are easily damaged if current flow is reversed through them.

The alternator system does not require a reverse current relay because of the high back resistance of the diodes and the inability of the alternator to draw current or motorize. A current regulator is unnecessary because the windings have been designed to limit the maximum current available. Therefore, the voltage control is the only control needed.

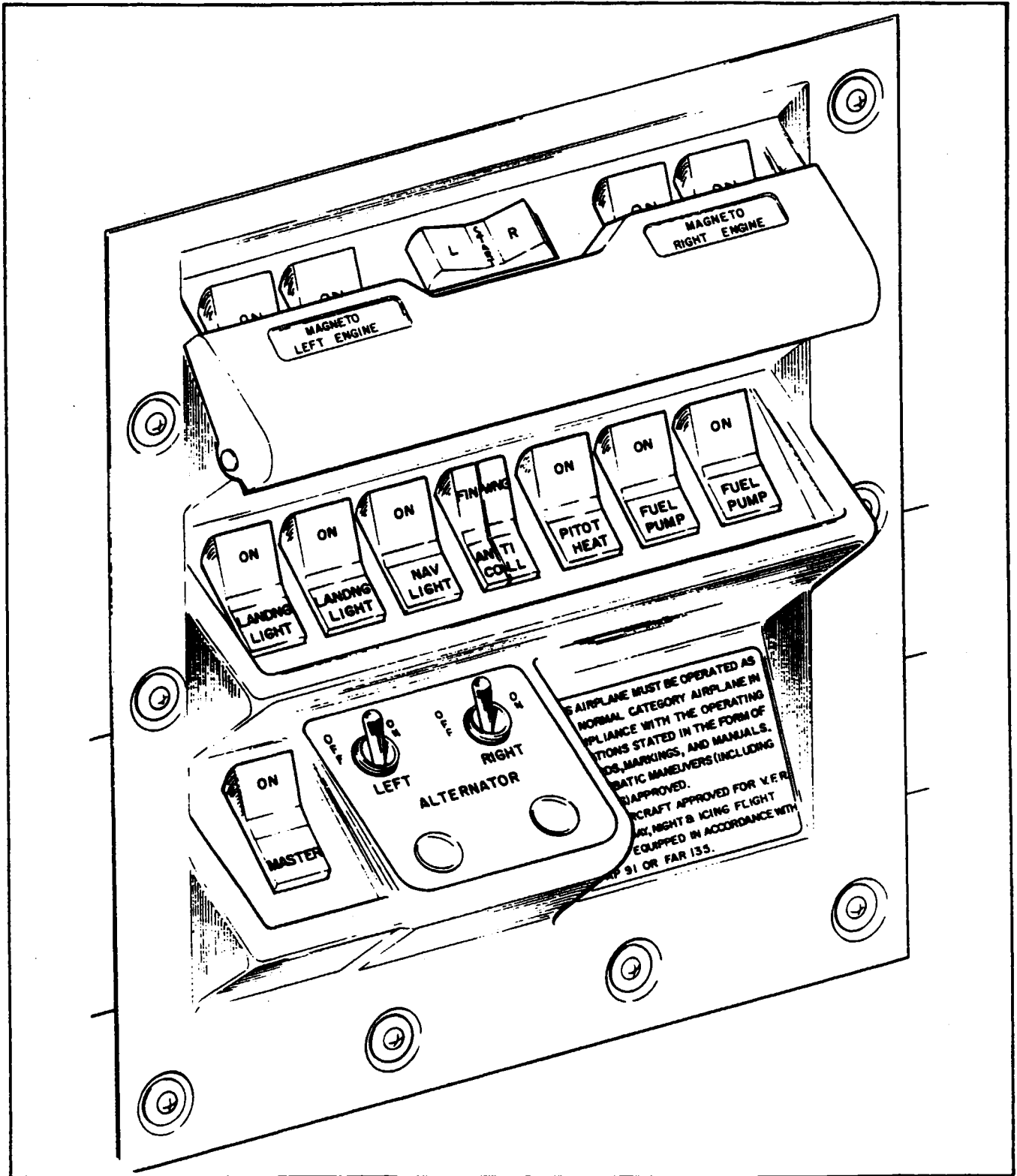

Figure 11-1. Switch Panel - Without Primer Switches

PIPER SENECA II SERVICE MANUAL

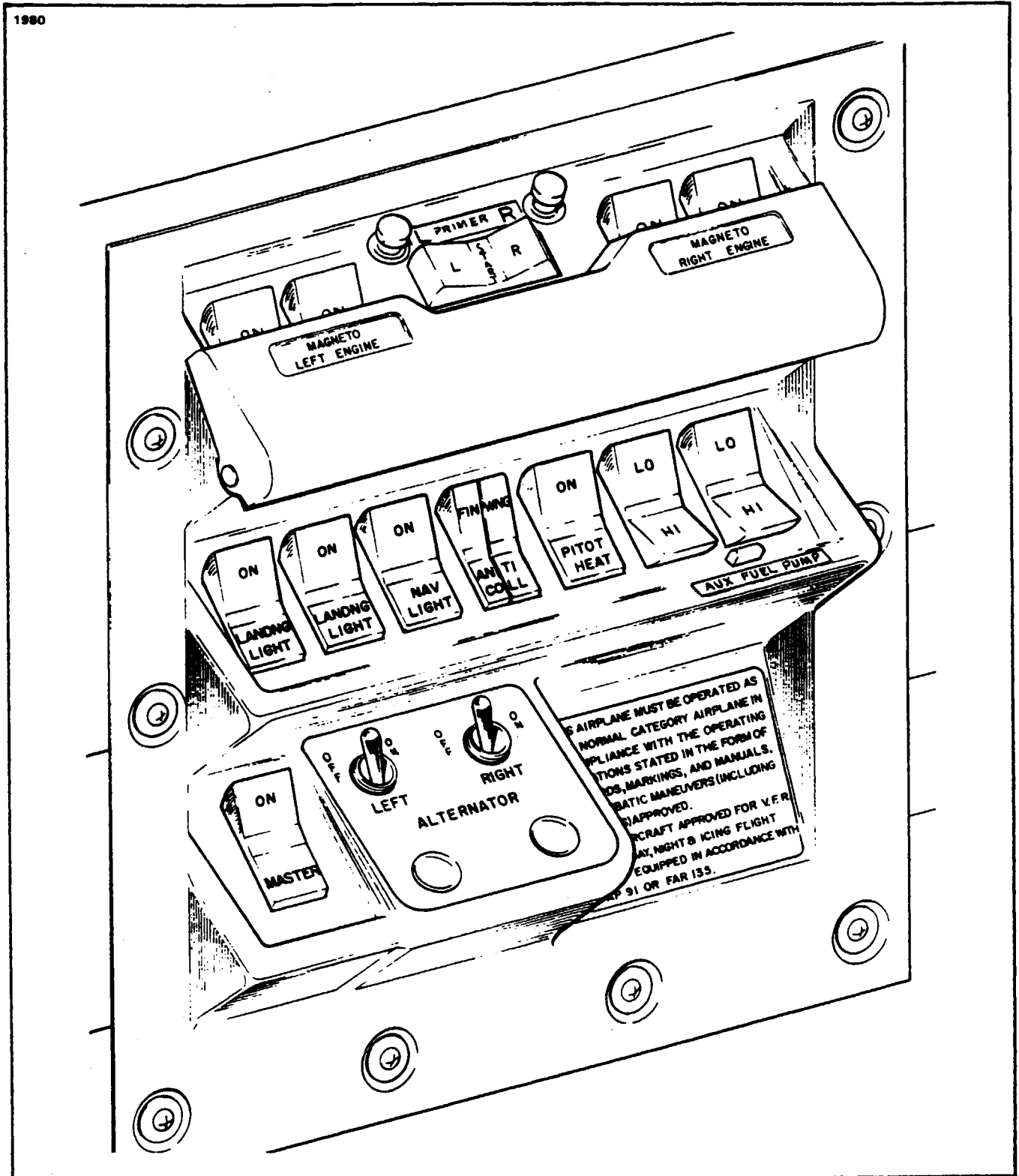

Figure 11-1a. Switch Panel - With Primer Switches

Reissued: 10/11/79

ELECTRICAL SYSTEM

2F22

Island Enterprises

The circuit breaker panel contains two 5 ampere circuit breakers marked ALT FIELD left and right. If the field circuit breakers trip, it will result in a complete shutdown of power from the particular generating system. After a one or two minute cool-down period, the breakers can be reset manually. If tripping reoccurs and holding the breakers down will not prevent continual tripping, then a short exists in the alternator field.

Unlike previous systems, the ammeters do not indicate battery discharge but displays the load in amperes placed on the particular generating system. With all electrical equipment off (except master), the ammeters will indicate the amount of charging current demanded by the battery. This amount will vary, depending on the percentage of charge in the battery at the time. As the battery becomes charged, the amount of current displayed on the ammeters will reduce to approximately two amperes. The amount of current shown on the ammeters will tell immediately whether or not the alternator systems are operating normally if the following principles are kept in mind.

NOTE

The amount of current shown on the ammeter is the load in amperes that is demanded by the electrical system from the alternator. As a check, take for example a condition where the battery is demanding 10 amperes charging current; then switch on the anti-collision light. Note, the value in amperes placarded on the panel for the anti-collision light circuit breaker (10 amps) and multiply this by 80 percent; you will arrive at a current of 8 amperes. This is the approximate current drawn by the anti-collision light. Therefore, when the anti-collision light is switched on, there will be an increase of current from 10 to 18 amperes displayed on the ammeter. As each unit of electrical equipment is switched on, the currents will add up and the total, including the battery, will appear on the ammeter.

11-5. ALTERNATOR AND COMPONENTS.

11-6. DESCRIPTION OF ALTERNATOR. The principal components of the alternator are the brush holder assembly, the slip ring end head, the rectifiers, the stator, the rotor and the drive end head.

a. The brush and holder assembly contains two brushes, two brush springs, a brush holder and insulators. Each brush is connected to a separate terminal stud and is insulated from ground. The brush and holder assembly can easily be removed for inspection or brush replacement purposes.

b. The slip ring end head provides the mounting for the rectifiers and rectifier mounting plate, output and auxiliary terminal studs, and the brush and holder assembly. The slip ring end head contains a roller bearing and outer race assembly and a grease seal.

c. The rectifiers used in these units are rated at 150 peak inverse voltage (PIV) minimum for transient voltage protection. Three positive rectifiers are mounted in the rectifier mounting plate while the three negative rectifiers are mounted in the slip ring end head. Each pair of rectifiers is connected to a stator lead with high temperature solder. The stator leads are anchored to the rectifier mounting plate with epoxy cement for vibration protection.

PIPER SENECA II SERVICE MANUAL

- d. The stator contains a special lead which is connected to the center of the three phase windings. The stator has been treated with a special epoxy varnish for high temperature resistance.
- e. The rotor contains the slip ring end bearing inner race and spacer on the slip ring end of the shaft. The rotor winding and winding leads have been specially treated with a high temperature epoxy cement to provide vibration and temperature resistance characteristics. High temperature solder is used to secure the winding leads to the slip rings.
- f. The drive end head supports a sealed, prelubricated ball bearing in which the drive end of the rotor shaft rotates, and a blast tube connection for ventilation.

11-7. CHECKING ALTERNATOR SYSTEM. Two ammeters are used which enable an independent output check of each alternator, as well as the electrical output-input of the battery. Should either alternator show no output on its ammeter, check the appropriate circuit breakers. If a further check of the ammeters show no output from both alternators, check the alternator system. (Refer to Combined Schematic Figure 11-23.)

- a. Ascertain that the ammeters are operating properly.
- b. Disconnect the battery lead (+) at the alternator.
- c. Disconnect field leads at the alternator.
- d. Ascertain that all electrical units are off and battery is full charged.
- e. Turn on the master switch.
- f. To check the alternator output circuit, connect a voltmeter or 12-volt test light to the battery lead and to ground. If a reading of approximately 12-volts registers on the voltmeter or the test lights, the battery circuit is operational.
- g. Should there be no indication of voltage, trace back through the output circuit until voltage is indicated. A component that allows no voltage to pass through it should be replaced.

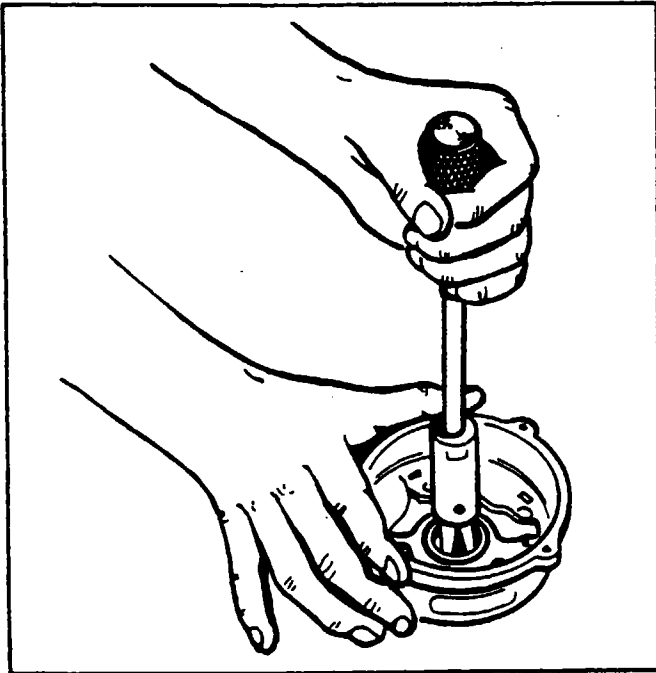

Figure 11-2. Removal of Slip Ring End Bearing

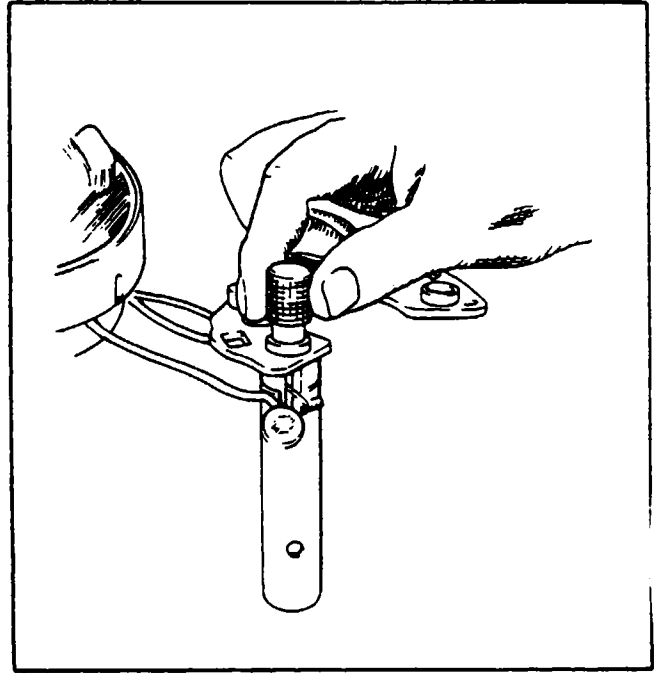

Figure 11-3. Removal of Rectifier

- h. Check the field circuit by the following procedure:
 - 1. On lead connected to (F1) terminal, connect a voltmeter to the field lead and to ground. If voltmeter indicates any voltage, the circuit is operational.
 - i. If voltage is indicated at both the battery lead and field lead, the alternator should be checked for possible malfunction. (Refer to Paragraph 11-9.)

11-8. SERVICE PROCEDURES. Since the alternator and regulator are designed for use on only one polarity system, the following procedures must be observed when working on the charging circuit. Failure to observe these service procedures will result in serious damage to the electrical equipment.

- a. When installing a battery, always make absolutely sure the ground polarity of the battery and the ground polarity of the alternator are the same.
- b. When connecting a booster battery, make certain to connect the negative battery terminals together and the positive battery terminals together.
- c. When connecting a charger to the battery, connect the charger positive lead to the battery positive terminal and the charger negative lead to the battery negative terminal.
- d. Never operate the alternator on open circuit. Make absolutely certain all connections in the circuit are secure.
- e. Do not short across or ground any of the terminals on the alternator or regulator.
- f. Do not attempt to polarize the alternator.

11-9. OVERHAUL OF ALTERNATOR. When repairing the alternator, complete disassembly may not be required. In some cases, it will only be necessary to perform those operations which are required to effect the repair. However, in this section, the complete overhaul is covered step-by-step to provide detailed information on each operation. In actual service practice, these operations may be used as required.

11-10. DISASSEMBLY OF ALTERNATOR.

- a. Remove the two Number 10-24 screws holding the brush holder assembly in the slip ring end head. Remove the brush and holder assembly from the end head.
- b. Remove the safety wire from the thru bolts and remove the thru bolts.
- c. Tap the drive end head lightly and separate the drive end head and rotor, as a unit from the stator and slip ring end head.
- d. Remove the nuts, lock washers, flat washers, and insulators from the output and auxiliary terminal studs. Note carefully the correct assembly of the insulator washers and bushings. Using the special tools shown in Figure 11-3, support the end head and press out the three negative rectifiers. The end head can now be separated from the stator assembly.
- e. To remove the slip ring end bearing and grease seal, it will be necessary to have a hook type or impact type bearing puller as shown in Figure 11-2. Do not remove the bearing unless replacement is necessary.

NOTE

The inner race of the slip ring end bearing is pressed onto the rotor shaft. When bearing replacement is necessary, always replace the complete bearing assembly including the inner race.

- f. Clamp the rotor in a vise and remove the cotter pin, nut, drive gear assembly and woodruff key.

NOTE

The drive assembly used on these alternators are not manufactured or serviced by Prestolite, but are available from the engine manufacturer.

- g. Support the drive end head and carefully press out the rotor assembly. Remove the retainer plate screws and retainer plate. Support the drive end head and press out the bearing. Remove the oil seal by pressing from inside of the housing.

2G3
INTENTIONALLY LEFT BLANK

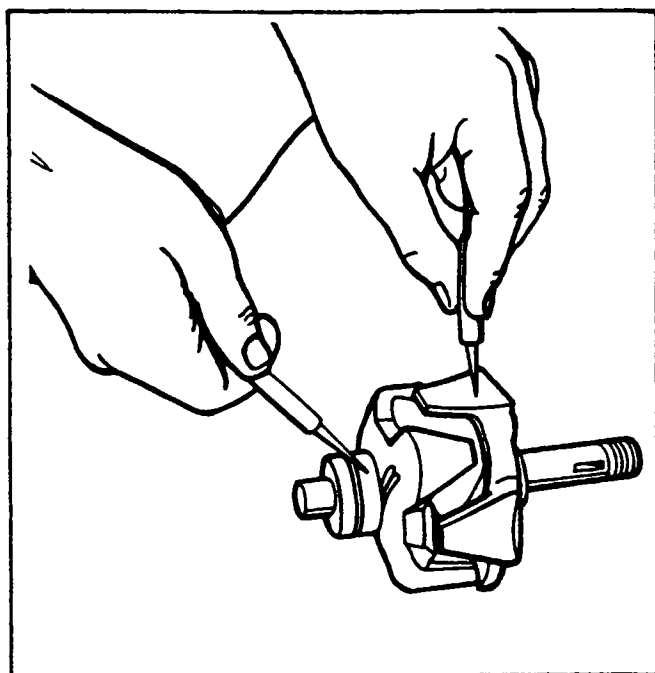

Figure 11-4. Testing Rotor for Ground

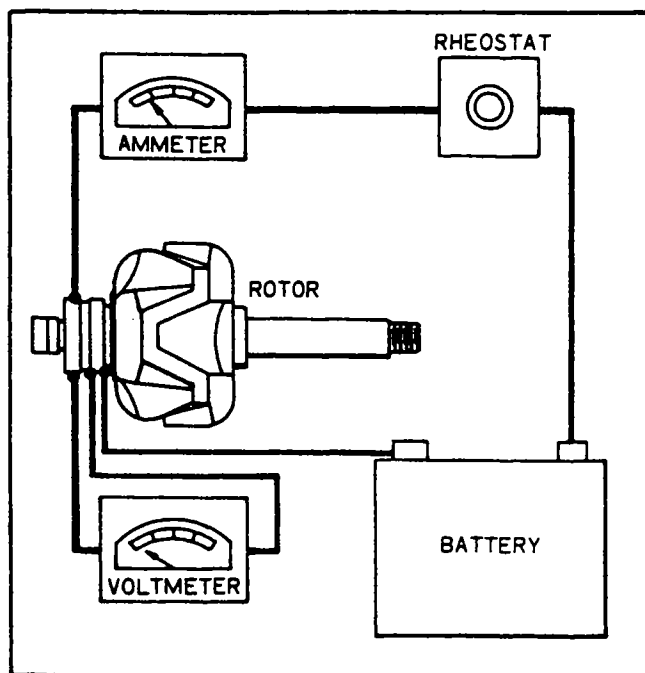

Figure 11-5. Testing Rotor for Shorts

11-11. INSPECTION AND TESTING OF COMPONENTS. Upon completion of the disassembly, all parts should be cleaned and visually inspected for cracks, wear or distortion, and any signs of overheating or mechanical interference.

a. **Rotor:** The rotor should be tested for grounded or shorted windings. The ground test can be made with test probes, connected in series with a 110-volt test lamp, an ohmmeter, or any type of continuity tester. (Refer to Figure 11-4.) There must not be any continuity between the slip rings and the rotor shaft or poles. To test for shorted turns in the rotor winding, connect a voltmeter, ammeter, and rheostat as shown in Figure 11-5 or use an ohmmeter. Rotor current draw and resistance are listed in the Alternator Service Test Specifications paragraph. Excessive current draw or low ohmmeter reading indicates shorted windings. No current draw or infinite ohmmeter reading would indicate an open winding.

b. **Rectifiers:** A diode rectifier tester will detect and pinpoint open or shorted rectifiers without going through the operation of disconnecting the stator leads. However, if a tester is not available, test probes and a Number 57 bulb, connected in series with a 12-volt battery, can be used in the following manner: Touch one test probe to a rectifier heat sink and the other test probe to a lead from one of the rectifiers in that heat sink; then reverse the position of the leads. The test bulb should light in one direction and not light in the other direction. If the test bulb lights in both directions, one or more of the rectifiers in that heat sink is shorted. To pinpoint the defective rectifier, the stator leads must be disconnected and the above test repeated on each rectifier. Open rectifiers can only be detected, when using the test bulb, by disconnecting the stator leads. The test bulb will fail to light in either direction if the rectifier is open.

c. **Stator:** The stator can be tested for open or grounded windings with a 12-volt test bulb, described in the rectifier section, or an ohmmeter in the following manner: Separate the stator from the slip ring end head just far enough to insert a fold of rags or blocks of wood. In other words, insulate the stator from the end head. To test for grounded windings, touch one test bulb or ohmmeter probe to the auxiliary terminal or any stator lead, and the other test bulb or ohmmeter probe to the stator frame. If the test bulb lights, or ohmmeter indicates continuity, the stator is grounded. To test for open windings, connect one test probe to the auxiliary terminal or the stator winding center connection and touch each of the three

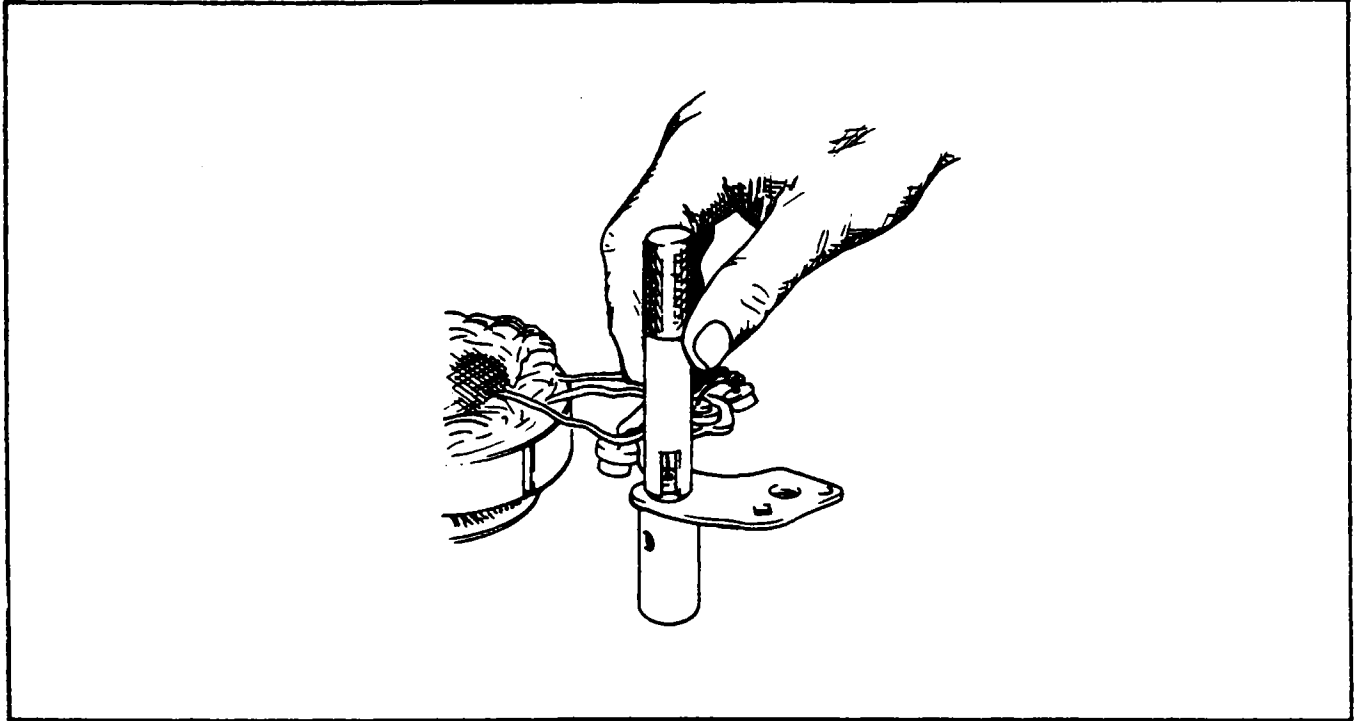

Figure 11-6. Installation of Rectifier

stator leads. The test bulb must light or the ohmmeter must show continuity. Due to the low resistance in the stator windings, shorted windings are almost impossible to locate. However, shorted stator windings will usually cause the alternator to “growl” or be noisy during operation and will usually show some signs of overheating. If all other electrical checks are normal and alternator fails to supply its rated output, the stator should be replaced to determine whether or not it is the faulty component.

d. **Bearings and Seals:** Whenever the alternator is overhauled, new bearings and oil or grease seals are recommended even though the bearings and seals appear to be in good condition. A faulty seal can cause an alternator to fail within a very short period of time.

11-12. ASSEMBLY OF ALTERNATOR.

- a. Reinstall the oil seal and end head bearing and retainer plate in the drive end head.
- b. Carefully install the rectifiers in the slip ring end head or rectifier mounting plate by supporting the unit and using the special tools illustrated in Figure 11-6.

CAUTION

Use an arbor press, do not hammer. Reconnect the stator leads to the rectifiers. When soldering these connections, use pliers as a heat dam on the lead between the solder joint and the rectifier. Too much heat will damage the rectifiers.

- c. Reassemble the rectifier mounting plate studs and insulators, making sure they are in the correct order. (Refer to Figure 11-7.)

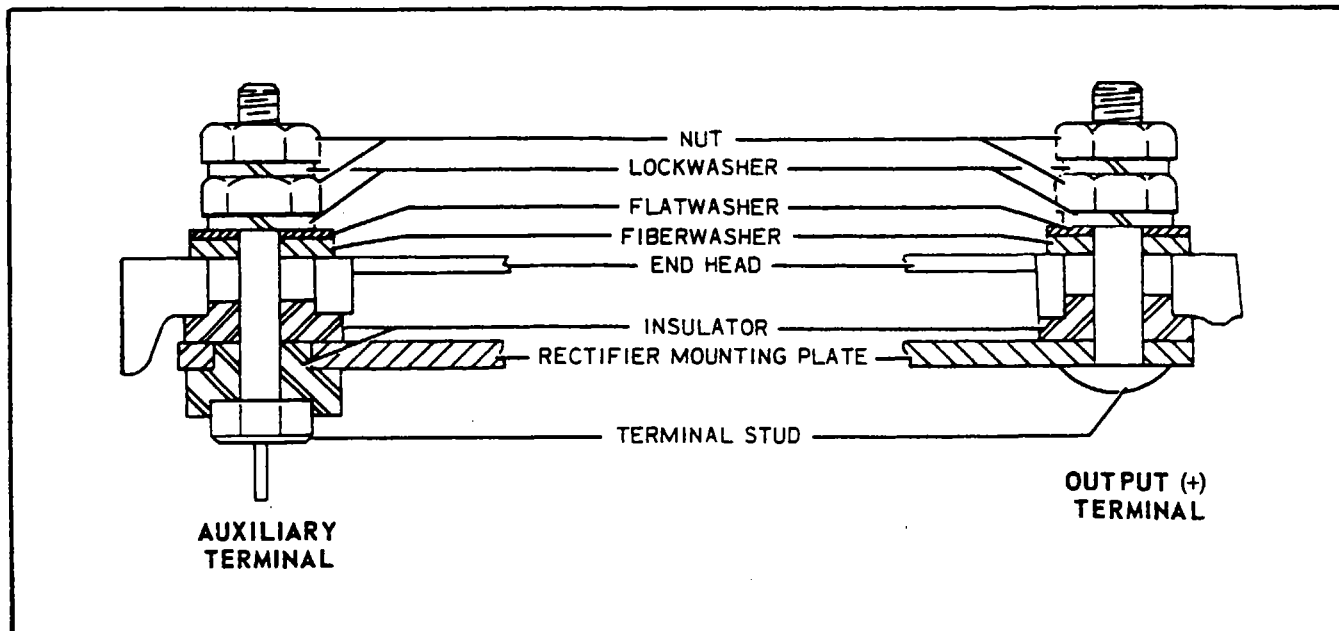

Figure 11-7. Terminal Assembly

d. After the slip ring end head is completely assembled, the stator and rectifier leads must be secured to the rectifier mounting plate with epoxy. Make sure the stator leads are positioned so that they do not interfere with the rotor.

e. Install the slip ring end bearing and oil seal. Make sure the lip of the oil seal is toward the bearing. Stake the seal in place. Correct assembly of bearing, seal, inner race and spacer as shown in Figure 11-8.

f. Assemble the alternator and install the through bolts. Spin the rotor to make sure there is no mechanical interference. Torque the through bolts to 30 to 35 inch-pounds. Safety wire should be installed after the unit has been bench tested for output.

g. Install the brush and holder assembly and retaining screws. Spin the rotor and check for interference between the brush holder and rotor. Check across the field terminals with an ohmmeter. The ohmmeter must indicate the amount of rotor resistance listed in Table XI-II.

11-13. TESTING ALTERNATOR. The alternator should be tested to determine if it is capable of delivering its full rated output.

CAUTION

The flange mounted alternator requires a source of ventilation. Do not test these alternators at full rated output for more than 30 seconds unless adequate air pressure for cooling is supplied.

a. Wiring connections for bench testing the alternator are shown in Figure 11-9. Output test specifications are given in Table XI-II. Adjust the carbon pile if necessary to obtain the specified voltage.

b. After bench testing the alternator, install the alternator on the engine, making sure all mounting surfaces are free of corrosion or foreign materials. Torque the alternator retaining bolts to the specifications listed in the engine manufacturer's manual.

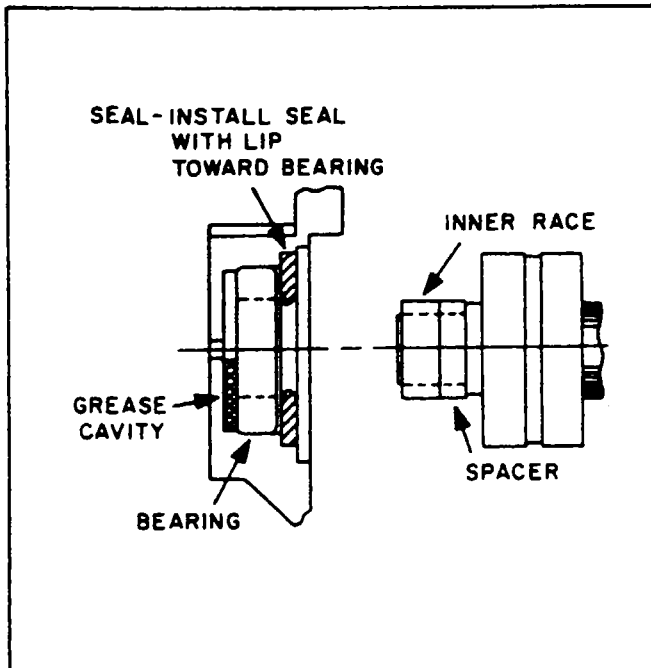

Figure 11-8. Slip Ring End Bearing Assembly

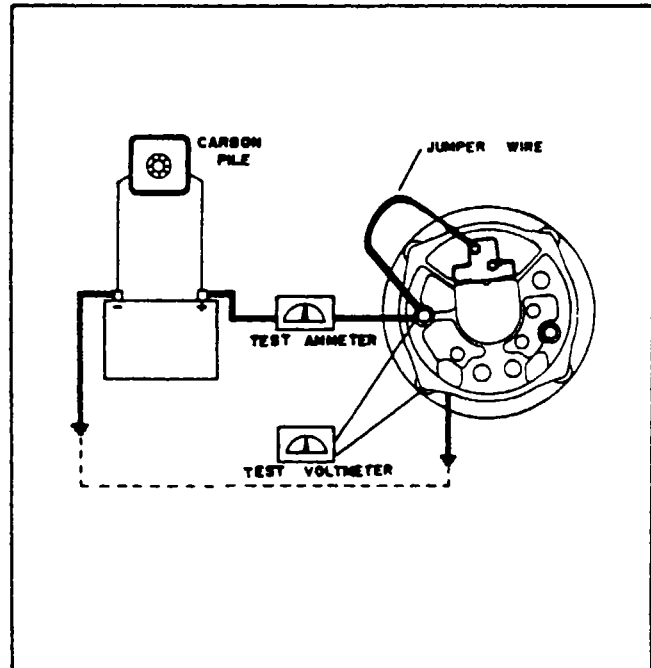

Figure 11-9. Testing Alternator

11-14. PRECAUTIONS. The following precautions are to be observed when testing or servicing the electrical system:

- a. Disconnect the battery before connecting or disconnecting test instruments (except voltmeter) or before removing or replacing any unit or wiring. Accidental grounding or shorting at the regulator, alternator, ammeter, or accessories will cause severe damage to the units and/or wiring.
- b. The alternator output lead must not be removed from the alternator with the field circuit energized and the alternator operating.
- c. Do not attempt to polarize the alternator. No polarization is required. Any attempt to do so may result in damage to the alternator, regulator or circuits.
- d. Grounding of the alternator output terminal may damage the alternator and/or circuit and components.
- e. Reversed battery connections may damage the rectifiers, aircraft wiring, or other components of the charging system. Battery polarity should be checked with a voltmeter before connecting the battery. The Seneca II has a negative ground.
- f. If a booster battery or fast charger is used, its polarity must be connected correctly to prevent damage to the electrical system components.
- g. When using an auxiliary power unit, make sure the voltage and polarity are set to correspond with the aircraft system voltage and polarity.

11-15. ALTERNATOR SERVICE TEST SPECIFICATIONS. Prestolite specifications for the 14-volt alternators installed as standard equipment on PA-34-200T airplanes are as follows:

TABLE XI-II. ALTERNATOR SPECIFICATIONS

Alternator Model	ALY 9402	
Voltage	12 volts	
Rated Output	65 amperes	
Ground Polarity	Negative	
Rotation	Bi-Directional	
Rotor:		
Current Draw (77° F)	3.2A nominal	4.0 max
Resistance (77° F)	4 ohm nominal	3 ohm min.
Output Test (77° F)		
Volts	14.0 ± .2	
Amperes Output	65	
Field Amperes	3.2A nominal	
Alternator RPM	5167	

11-16. ALTERNATOR NOMENCLATURE.

a. Bearings: These units have a sealed ball bearing at the drive end and a two-piece roller bearing at the slip ring end. The inner race is pressed onto the rotor shaft and the rest of the bearing is in the slip ring end head. When the unit is assembled, the inner race aligns with the bearing. When the bearing is replaced, the new inner race must be installed on the rotor shaft.

b. Lubrication: The slip ring end bearing should be lubricated whenever the alternator is disassembled. The bearing should be thoroughly cleaned and repacked with Shell Alvania No. 2 or an equivalent bearing lubricant. The cavity behind the bearing should be packed one-third to one-half full with the same lubricant.

c. Brushes: These units have a separate brush holder assembly that is installed after the alternator has been assembled. The brush holder has a small hole that intersects the brush cavities. Use a pin or a piece of wire to hold the brushes in the holder during assembly. Remove the pin after the brush holder retaining screws have been tightened. Make a continuity check to be sure the brushes are seated against the slip rings.

11-17. VOLTAGE REGULATOR.

11-18. REGULATOR COMPONENTS. Alternator output voltage can within limits of the design capability of the alternator be controlled by properly varying the average level of current flow in the rotor winding. The solid state electronic regulator is well suited for this purpose. The alternator, due to its design, has self-limiting current characteristics and therefore needs no current limiting element in the regulator.

- a. Transistor: The transistor (Symbol "Q") is an electronic device which can control the flow of current in an electric circuit. It has no mechanical or moving parts to wear out.
- b. Rectifier Diode: The rectifier diode (Symbol "D") will pass current in only one direction (forward direction), and in this respect, it may be compared to a check valve.
- c. Zener Diode: The zener diode (Symbol "Z") in addition to passing current in the forward direction will also pass current in the reverse direction when a particular value of reverse voltage is applied. This property makes it useful as a voltage reference device in the regulator.
- d. Capacitor: The capacitor (Symbol "C") is a device which will store electrical energy for short periods of time. This property makes it useful as a filter element to smooth variations of voltage.
- e. Resistor: The resistor (Symbol "R") is a device which is used to limit current flow.

11-19. OPERATION OF REGULATOR. (Refer to Figure 11-10.)

- a. When the alternator is turned on, battery voltage is applied to the "BUS" terminal of the regulator and via Q4 through the "FIELD" terminal of the regulator to the alternator field terminal F2. The amount of voltage applied to the field of the alternator is controlled automatically by action of the regulator in response to alternator output as described below.
- b. Current flow through R6 and Z1 establishes a reference voltage across Z1.
- c. Resistors R1 and R2/R3 comprise a voltage divider which is adjustable by means of the variable portion R3. Voltage at the junction of R1 and R2 and the reference voltage across Z1 are applied to comparison transistor Q1. R3 is adjusted so that these voltages are balanced with the desired alternator output voltage present on the "BUS" terminal of the regulator.
- d. Thereafter, whenever alternator output voltage (as applied to the "BUS" terminal) falls below the desired regulation value, the comparison transistor Q1 will supply increased current to driver transistors Q2/Q3, which in turn will drive power transistor Q4 to a higher value of field current. This will result in alternator output voltage increasing to a value which will restore balance between the two voltages applied to Q1.
- e. Conversely, if alternator output voltage (as applied to the "BUS" terminal) increases due to a greater engine speed or reduced loading of the electrical system, the comparison transistor Q1 will act to reduce current flow to the driver transistors Q2/Q3, and thus reduce the drive to power transistor Q4. This will result in a reduction of alternator field current and automatically restore balance between the two voltages applied to comparison transistor Q1.
- f. Capacitors C1 and C2 function together with their related transistors in a way to smooth alternator output ripple and voltage spikes so that the alternator field current is controlled at a steady value.
- g. The solid state regulator controls alternator field current to a steady value as required by the electrical load conditions and engine speed. It does not continuously switch field current between high and low values as do mechanical regulators and the switching type of electronic regulators.
- h. The design of this unit is such as to provide an alternator output voltage that does not vary with ambient temperature.

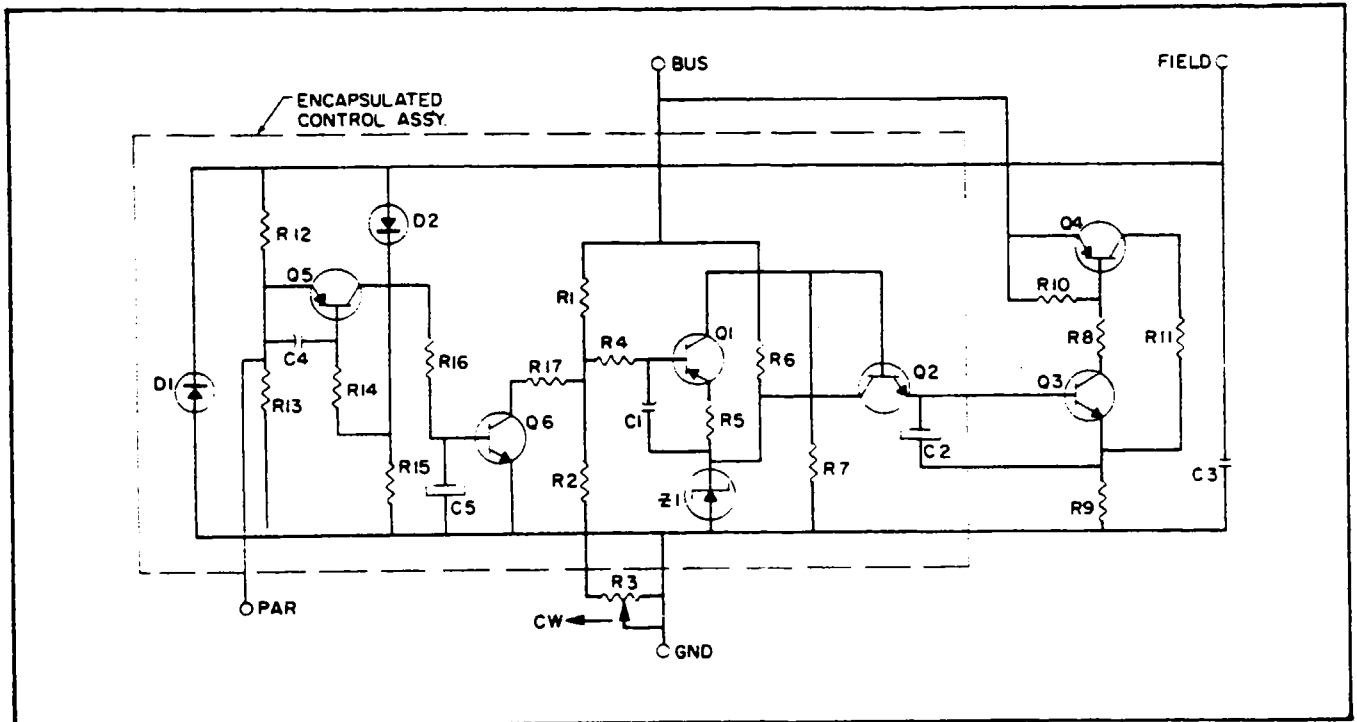

Figure 11-10. Regulator Diagram

11-20. BALANCING CIRCUIT OPERATION. (Considering two identical alternators and regulators having the "PAR" terminals of the regulators connected.)

- a. Balancing circuit operation is initiated within one regulator whenever individual field voltages delivered by the regulator units to their related alternators are not equal.
- b. When a difference in individual field voltages occurs, one-half the difference is impressed across R12 within each regulator and is thus applied to the input of Q5.
- c. In that regulator which is delivering the lower field voltage, the polarity of R12 voltage drop causes Q5 collector current flow.
- d. Q5 collector current flow results in conduction occurring in the collector circuit of Q6.
- e. Q6 collector current flows from regulator divider R1/R2+R3 through limiting resistor R17 to ground.
- f. Conduction through R17 effectively alters the ratio of the regulator divider R1/R2+R3 in the direction to increase Q1 collector current flow.
- g. As described above under REGULATING CIRCUIT OPERATION, increased Q1 current results in increased output from the regulator to the field of its related alternator.
- h. Feedback action results in Q6 collector current stabilizing at a value that results in nearly equal field voltage being delivered by the two regulators to their respective alternator fields.
- i. The balancing circuit will thus automatically maintain, at a low value, the difference voltage applied to the alternator fields. In a parallel system having identical alternators operating at the same RPM, the output currents of the alternators will thus be maintained nearly equal.
- j. In whichever regulator of a pair is set to deliver the highest voltage, the balancing circuits are inactive. Thus, system voltage is determined by the regulator of a pair which is set to higher voltage. The lower set regulator will adjust itself automatically as described above to deliver the same field voltage as the one which is set higher within the limits of its design capability.

PIPER SENECA II SERVICE MANUAL

k. The balancing regulator system as described provides for automatic load balancing of parallel operated alternators having independent field excitation circuits. The pilot can while in flight remove either alternator system completely from the aircraft system and maintain operation of the other system.

11-21. PREPARATION FOR TESTING. (Regulators may be tested using the aircraft's alternator or an alternator test stand.)

CAUTION

Do not interchange regulator leads. This will destroy regulator and void warranty.

a. The aircraft technician or other electrical system's specialist must disconnect the battery ground cable at the battery before connecting or disconnecting a test ammeter or other test equipment or before making wiring changes in the electrical system.

b. Voltmeters with test probes or clips are not recommended. Fully insulated bolted terminal connections are best and these should be attached when all power is removed as described above.

c. When installing a battery in an aircraft, be sure that the battery negative terminal is in a position so that this terminal can be connected to the battery ground cable for negative ground systems.

d. The regulator under test is to be mounted on a grounded metallic surface using three No. 8 screws pulled up tight. For extended test periods the heat transfer from regulator to the mounting surface is significant.

e. A ground wire between the regulator "GND" terminal and the aircraft or test stand structure is essential for proper operation. The alternator frame must also be solidly bonded to the system ground.

f. The alternator does not need to be polarized; therefore, never connect ground even momentarily to either the regulator field terminal or to the alternator field terminals. Do not interchange leads to regulator as this will destroy the regulator.

CAUTION

Never under any circumstance permit a ground to contact the field circuit even for an instant while power is applied to the system.

g. The alternator should be in good condition and capable of producing full output, and the alternator drive belt must be adjusted tight enough to prevent slippage.

h. The battery must be in good condition and should be fully charged.

i. The voltmeter and ammeter should be of the best quality and should be accurate.

j. A carbon pile connected across the battery may be used to load the charging circuit while testing the regulator.

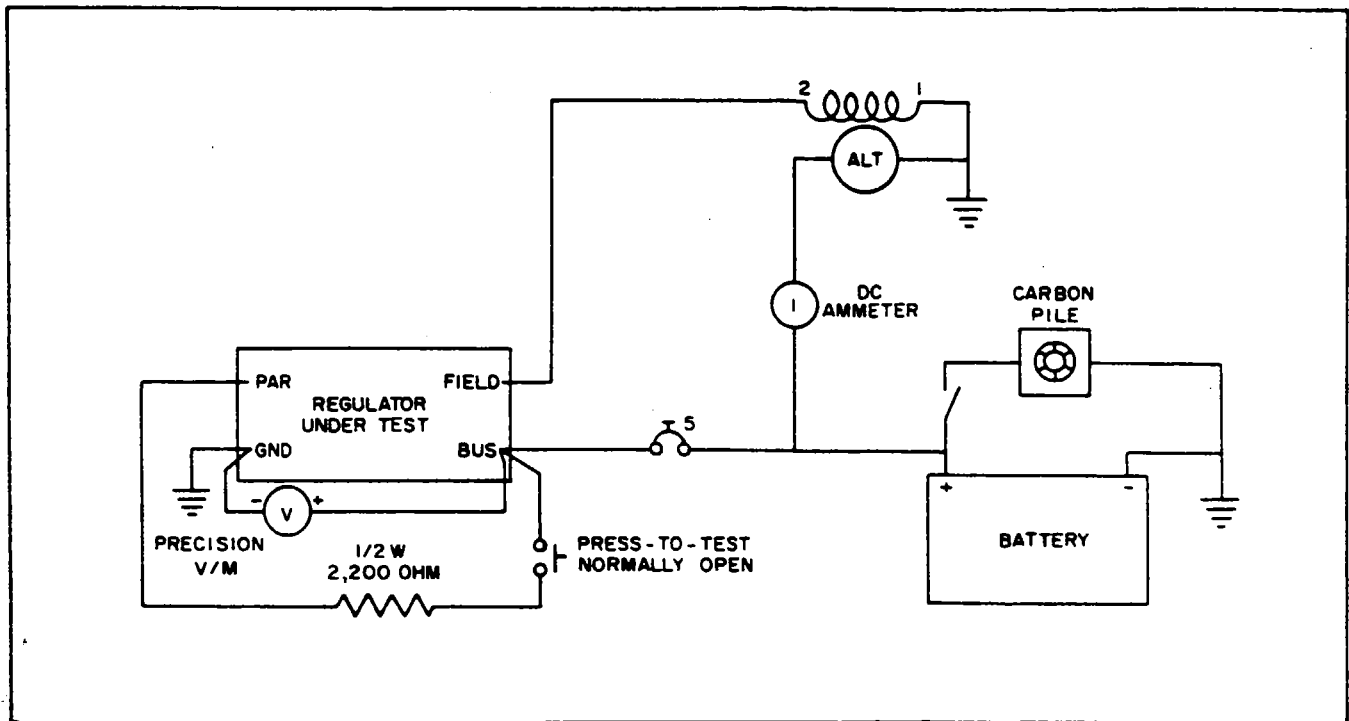

Figure 11-11. Testing Regulator

11-22. TESTING REGULATOR.

- a. The procedure for testing the regulator whether on the airplane or on the test bench remains the same. Connect the test meters and regulator wiring as shown in Figure 11-11.
- b. All circuit connections should be clean and tight. This includes the test instrument connections which must not come loose or open the charging circuit at any time while the system is operating.
- c. The voltmeter will not indicate the true regulator setting until the regulator has been operating in the charging system or on the test bench for at least five minutes, at a charge rate of from 10 to 15 amperes.
- d. With the connections made as shown in Figure 11-11, start the engine and adjust its speed to approximately 920 to 1250 RPM to obtain 3,000 to 4,000 alternator RPM. Turn on accessories as needed to establish a 10 to 15 ampere load value. Note that the battery charge current is indicated by the ammeter. Therefore, the current value may change downward at the beginning of a test run. This will be especially true if the battery was used for engine starting.
- e. After one minute operating time, check the regulator operating voltage as indicated by the voltmeter. Refer to Alternator Service Test Specifications, Paragraph 11-15 for the correct operating voltage. The operating voltage is shown for the ambient temperature in which the regulator is operating.
- f. If the voltmeter reading indicates that the operating voltage is not within limits, lift the plastic plug from top of regulator and adjust the voltage to the desired value. Replace the plug after adjustment. Before condemning the regulator, recheck the alternator and the battery, making sure that they are in good condition. Recheck all circuit connections and all wiring for unwanted resistance (voltage drop test). Recheck the voltmeter for accuracy and repeat the entire operating test.

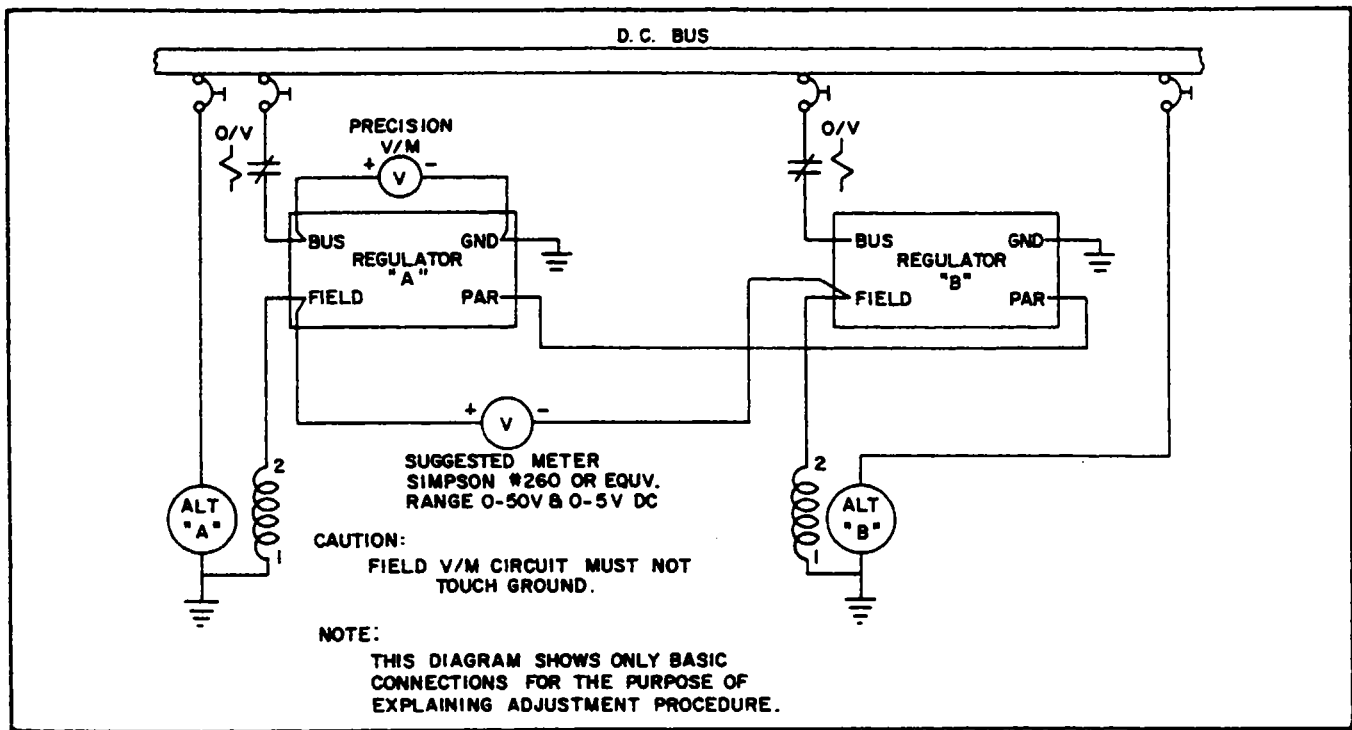

Figure 11-12. Adjusting Regulator

11-23. ADJUSTING REGULATOR. These regulators are normally used in parallel alternator systems of multi-engine aircraft. Their final adjustment should be made in actual operation in the aircraft system with test equipment connected as shown in Figure 11-12. The balance adjustment is made while operating only one engine, either left or right. The engine to be operated must be selected so as to permit the technician a completely safe access to both of the regulators, so that they may be adjusted while the engine is operative without danger.

CAUTION

Extra caution must be exercised due to the proximity of the regulators to the propellers. It is necessary to operate only one engine for this procedure.

- a. Gain access to the regulators by removing the right rear closeout cover in the nose baggage compartment aft of the nose gear. Remove the plugs from the regulator adjustment holes.
- b. Open the paralleling circuit by removing the wire from the "PAR" terminal of either regulator and insulate the free end so it will not contact other circuits or ground during the adjustment procedure.

Breaking this circuit disables the balancing circuits in both regulators.

c. Operate the "RIGHT" engine at approximately 1750 RPM and at a load of 15 to 30 amperes for approximately 5 minutes for warm-up; then turn the "LEFT" alternator switch "OFF" and set the RIGHT voltage regulator (to the left while facing aft) to 14.0-volts; then replace its plug button. This regulator should require no further adjustment.

d. Connect a voltmeter between the two "FIELD" terminals, turn the LEFT alternator switch ON, and adjust for minimum voltage; however, the voltage should not exceed 8-volts. This adjustment will be "touchy," and polarity will reverse as zero is passed.

e. Reconnect the PAR wire and note that the voltage as observed in Step 4 drops to less than .5-volt and becomes steady. Check that bus voltage is still 14.0-volts; then shutdown engine.

f. Replace the plug in the regulator; remove all voltmeter leads and test equipment and install the closeout panel in the baggage compartment.

11-24. OVERVOLTAGE RELAY.

11-25. CHECKING OVERVOLTAGE RELAY. The relay may be tested with the use of a good quality, accurate voltmeter, with a scale of at least 20-volts and a suitable power supply, with an output of at least 20-volts, or sufficient batteries with a voltage divider to regulate voltage. The test equipment may be connected by the following procedure:

- a. B+ is connected to "Bat" of the overvoltage control.
- b. B- is connected to the frame of the overvoltage control.
- c. Be sure both connections are secure and connected to a clean bright surface.
- d. Connect the positive lead of the voltmeter to the "Bat" terminal of the overvoltage control.
- e. Connect the negative lead of the voltmeter to the frame of the overvoltage control.
- f. The overvoltage control is set to operate between 16.5-volts to 17.5-volts. By adjusting the voltage an audible "click" may be heard when the relay operates.
- g. If the overvoltage control does not operate between 16.5 and 17.5-volts, it must be replaced.

PIPER SENECA II SERVICE MANUAL

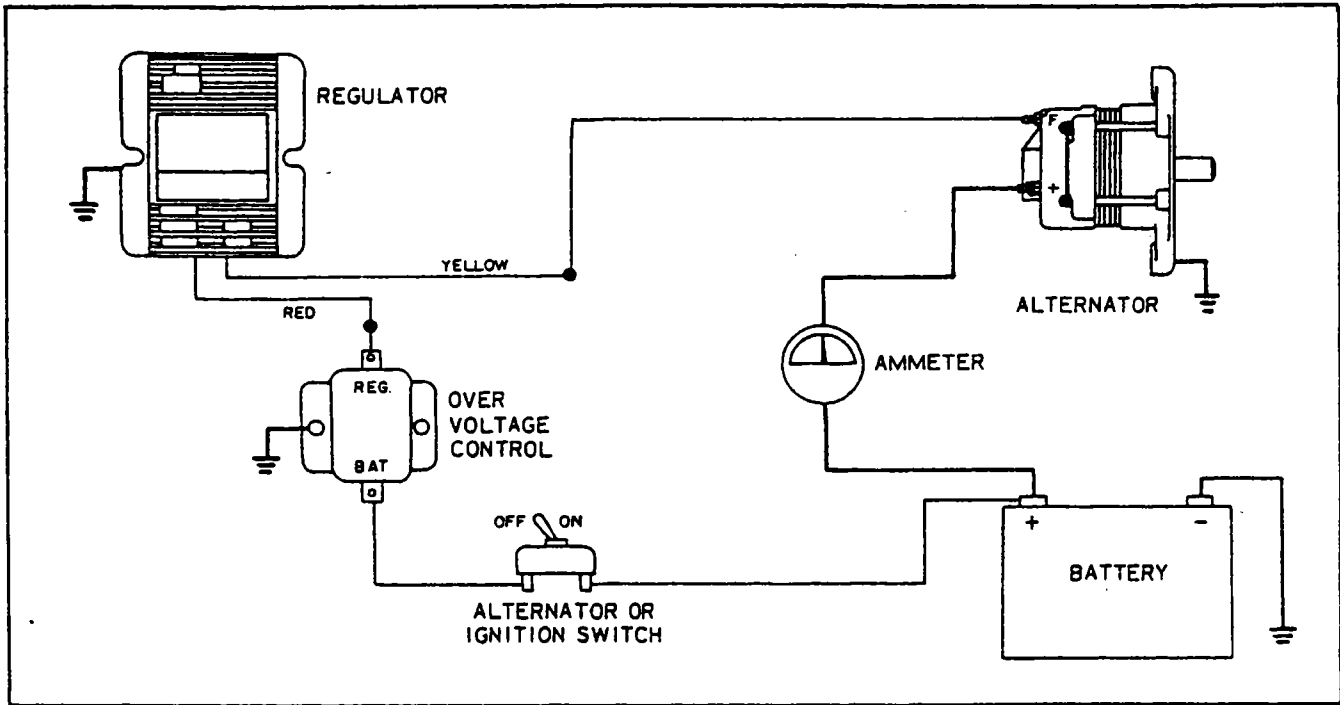

Figure 11-13. Application of Overvoltage Control

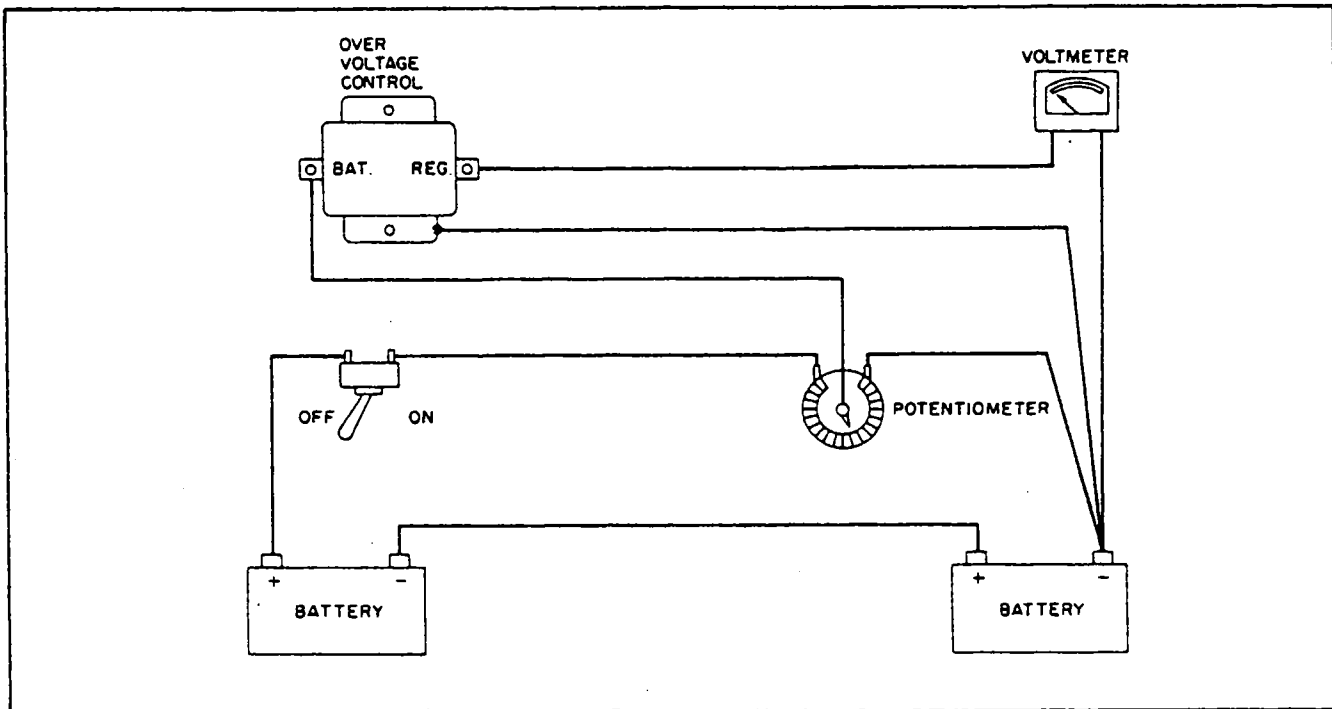

Figure 11-14. Testing Overvoltage Control

11-26. STARTING MOTORS.

11-27. DESCRIPTION. The starting motor consists of five major components: the commutator end head assembly, the brush set and plate assembly, the frame and field assembly, the armature, and the drive end head assembly. (Refer to Figure 11-15.)

11-28. OPERATION. When the starting circuit is energized, battery current is applied to the starting motor terminal. Current flows through the field coils creating a strong magnetic field. At the same time, current flows through the brushes to the commutator through the armature windings to ground. The magnetic force created in the armature combined with that created in the field windings begins to turn the armature.

11-29. MAINTENANCE. The starting circuit should be inspected at regular intervals; the frequency of which should be determined by the amount of service and the condition under which the aircraft is operated. It is recommended that such inspection be made at each 100 hours and include the following:

a. The battery should be checked with a hydrometer to be sure it is fully charged and filled to the proper level with approved water. A load test should be made to determine battery condition. If dirt and corrosion have accumulated on the battery, it should be cleaned with a solution of baking soda and water. Be sure none of the solution enters the battery cells.

b. The starting circuit wiring should be inspected to be sure that all connections are clean and tight and that the insulation is sound. A voltage loss test should be made to locate any high resistance connections that would affect starting motor efficiency. This test is made with a low reading voltmeter while cranking the engine or at approximately 100 amperes and the following limits should be used:

1. Voltage loss from insulated battery post to starting motor terminal - 0.3-volt maximum.
2. Voltage loss from battery ground post to starter frame - 0.1-volt maximum.

NOTE

If voltage loss is greater than the above limits, additional tests should be made over each part of the circuit to locate the high resistance connections.

NOTE

If a solderless terminal on an aluminum cable is loose, corroded or otherwise unsatisfactory, it is recommended that the complete cable assembly be replaced instead of replacing or repairing the solderless terminal.

Should replacement of the complete assembly not be practical, it is permissible to replace the aluminum cable assembly with a copper cable assembly which is two sizes smaller (Ex: an AL-1 Aluminum Cable Assembly is replaced with an AN-3 copper cable assembly). The new cable should be installed in accordance with AC-43-13-2A.

c. No lubrication is required on the starting motor except at the time of overhaul. Soak new absorbent bronze bearings in SAE 20 oil before installation. Saturate the felt oiling pad in the commutator end head with SAE 20 oil. Allow excess oil to drain out before installing end head on motor. Put a light film of Lubriplate 777 on the drive end of the armature shaft before and after installing the drive end head.

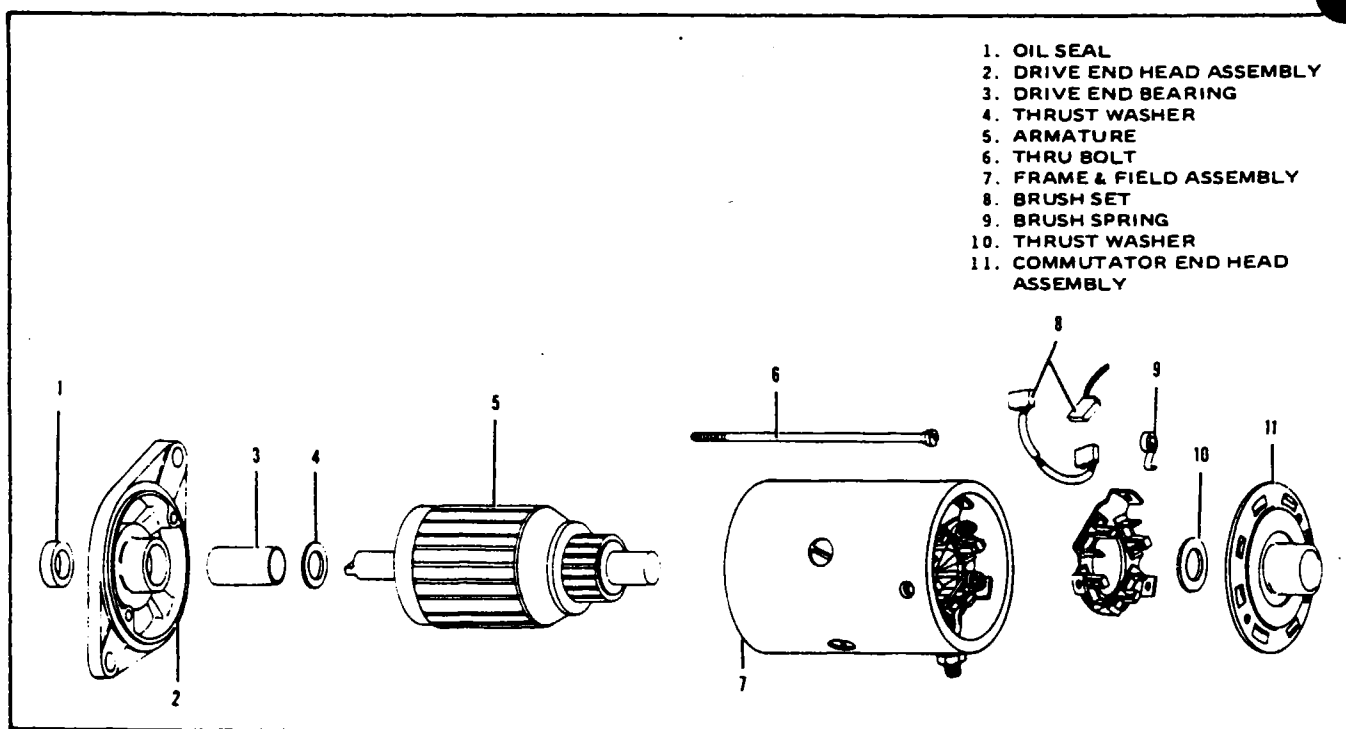

Figure 11-15. Exploded View of Starting Motor

d. The starting motor should be operated for a few seconds with the ignition switch off. This is to determine that the starter engages properly and that it turns freely without binding or excessive noise. Start the engine two or three times to check the starter drive assembly.

NOTE

Refer to the engine manufacturer's service information concerning the starter drive mechanism.

11-30. OVERHAUL. If during the above inspection any indication of starting motor difficulty is noted, the starting motor should be removed from the engine for cleaning and repair.

11-31. REMOVAL. To remove the starting motor from the engine first disconnect the ground cable from the battery post to prevent short circuiting. Disconnect the lead from the starting motor terminal; then take out the mounting bolts. The motor can then be lifted off and taken to the bench for overhaul.

11-32. DISASSEMBLY.

- a. Remove the safety wire and thru bolts from the commutator end and pull the end head from the frame.
- b. Pull the drive end head and armature from the frame and separate the drive end head from the armature.
- c. The drive end bearing may be removed by pressing out of the drive end head.
- d. Each part should be cleaned and inspected for excessive wear or damage. Bearing should be checked for proper clearance and evidence of roughness or galling. Oil and dirt should be removed from insulation and the condition of the insulation checked.

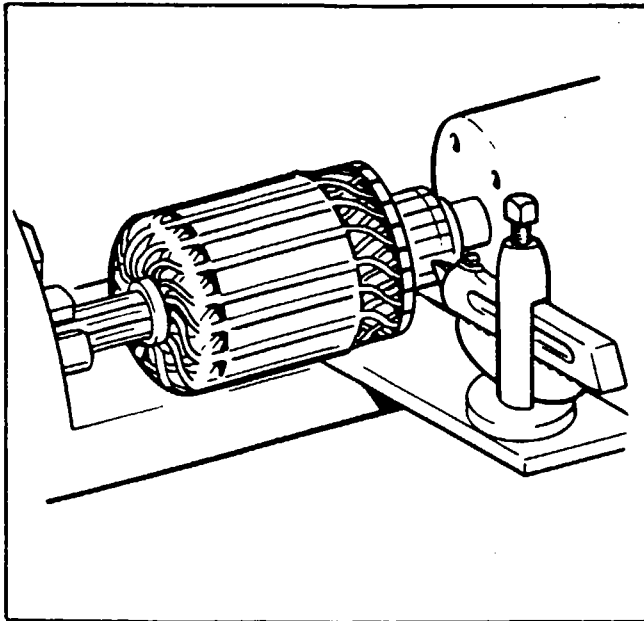

Figure 11-16. Turning Motor Commutator

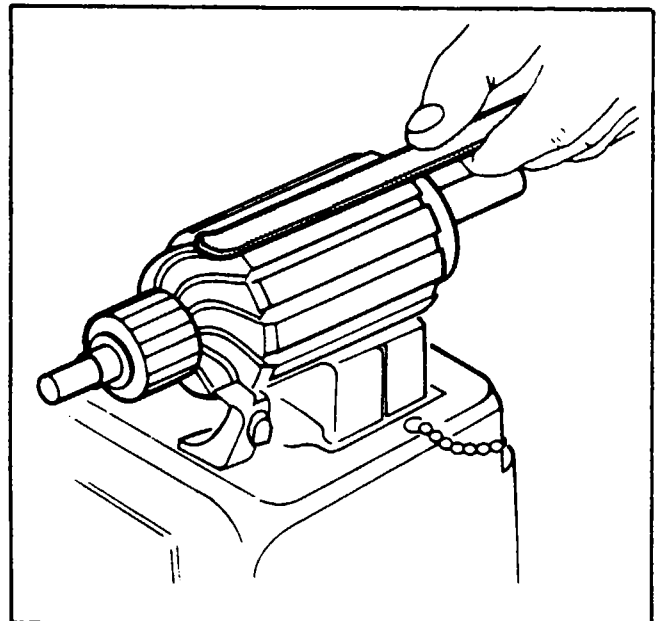

Figure 11-17. Testing Motor Armature for Shorts

11-33. BRUSHES. Check the brushes to see that they slide freely in their holders and make full contact on the commutator. If worn to half their original length or less, they should be replaced.

11-34. ARMATURE.

a. Check the commutator for uneven wear, excessive glazing, or evidence of excessive arcing. If only slightly dirty, glazed or discolored, the commutator can be cleaned with 00 or 000 sandpaper. If the commutator is rough or worn, it should be turned in a lathe. (Refer to Figure 11-16.) The armature shaft should be inspected for rough bearing surfaces and rough or damaged splines.

b. To test the armature for grounds, a set of test probes connected in series with a 110-volt light should be used. Touch one probe to a commutator segment and the other to the armature core. If the test lamp lights, the armature is grounded and should be replaced.

c. To test for shorted armature coils, a growler is used. (Refer to Figure 11-17.) The armature is placed on the growler and slowly rotated by hand while a steel strip is held over the core so that it passes over each armature core slot. If a coil is shorted, the steel strip will vibrate.

d. A quick check for opens can be made by inspecting the trailing edge (in direction of rotation) of the commutator segments for excessive discoloration. This condition indicates an open circuit.

11-35. FIELD COILS.

a. Check the field coils for grounds (refer to Figure 11-18) by placing one test probe on the frame and the other on the starter terminal. Be sure the brushes are not accidentally touching the frame. If the lamp lights, the fields are grounded. Repair or replace.

b. Inspect all connections to make sure they are clean and tight and inspect insulation for deterioration.

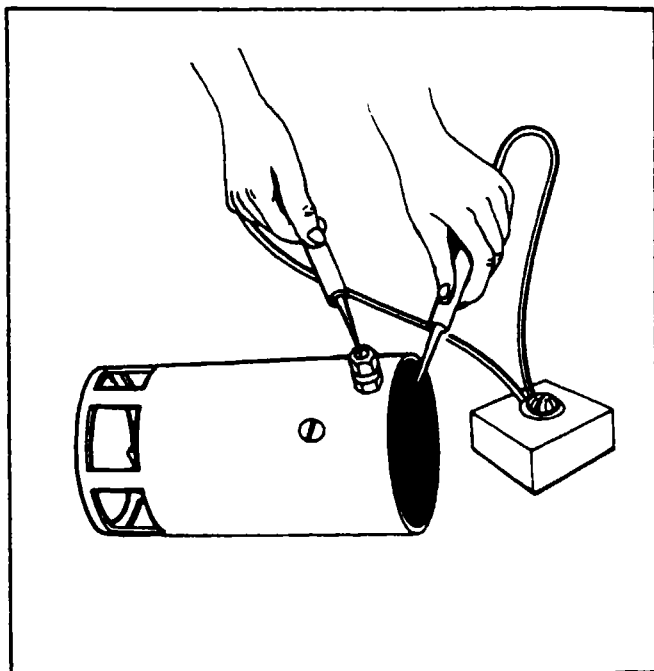

Figure 11-18. Testing Motor Fields for Grounds

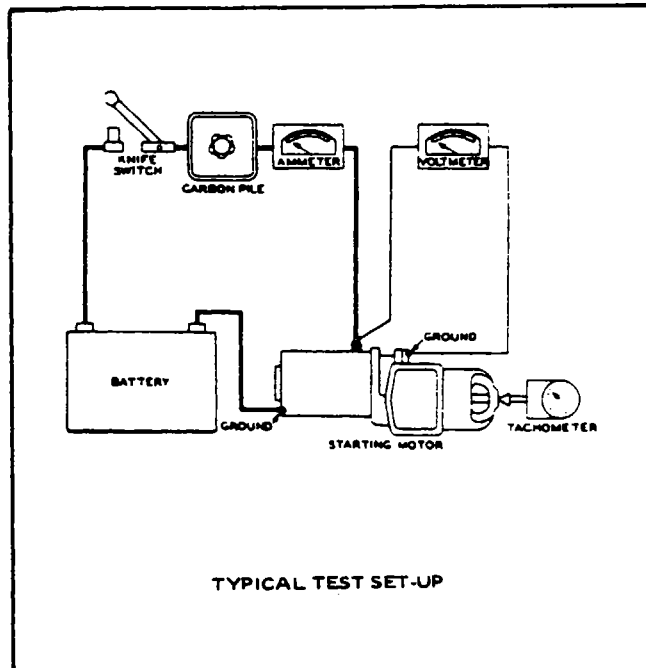

Figure 11-19. No-Load Test Hookup

11-36. BRUSH HOLDERS.

- a. To test brush holders, touch one test probe to the brush plate and the other to each brush holder.
- b. The test lamp should light when the grounded brush holders are touched and should not light when the insulated brush holders are touched.

11-37. ASSEMBLY.

- a. When assembling the starting motor always use an arbor press and the proper bearing arbor for installing graphitized bronze bearings.
- b. Soak new absorbent bronze bearings in SAE 20 oil before installation. Saturate the felt oiling pad in the commutator end head with SAE 20 oil. Allow excess oil to drain out before installing end head on motor. Put a light film of Lubriplate 777 on the drive end of the armature shaft before and after installing the drive end head.
- c. New brushes should be properly seated when installing by wrapping a strip of 00 sandpaper around the commutator (with the sanding side out) 1-1/4 to 1-1/2 times maximum. Drop brushes on sandpaper covered commutator and turn the armature slowly in the direction of rotation. Dust should be blown out of the motor after sanding.

NOTE

The spring tension is 32 to 40 ounces with new brushes. This tension is measured with the scale hooked under the brush spring near the brush and the reading is taken at right angles to the line of force exerted by the brush spring.

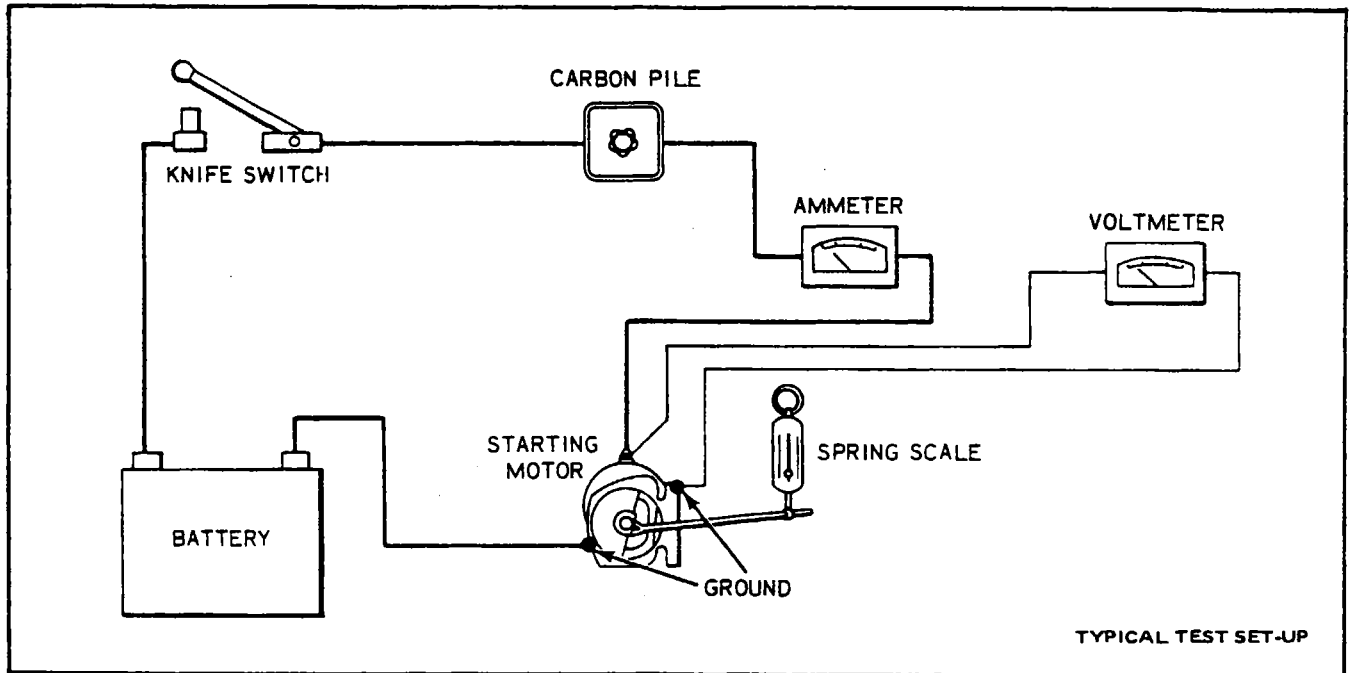

Figure 11-20. Stall Torque Hookup

11-38. BENCH TESTS.

a. After the starting motor is reassembled, it should be tested to see that the no-load current at a certain voltage is within specifications as given in Paragraph 11-40. To make this test, connect as shown in Figure 11-19. If current is too high, check the bearing alignment and end play to make sure there is no binding or interference. Two or three sharp raps on the frame with a rawhide hammer will often help to align the bearings and free the armature.

b. If no difficulty is indicated in the above test, a stall torque test may be made to see if the starting motor is producing its rated cranking power. Make test connections as shown in Figure 11-20.

c. If torque and current are not within specifications, check the seating of the brushes and internal connections for high resistance. If these checks are made and found to be in good order, replace frame and field assembly and retest starter.

11-39. STARTING MOTOR CONTROL CIRCUIT.

a. Inspect the control circuit wiring between the battery, solenoid and manual starting switches for breaks, poor connections and faulty insulation. Tighten all connections and make sure solenoid is firmly mounted and makes a good ground connection.

b. Check the voltage loss across the switch contacts during normal starting. If loss is in excess of 0.2 volts per 100 amperes, the solenoid should be replaced.

c. If solenoid fails to operate when the manual starting switch is turned on or if it fails to release when the manual starting switch is released, it should be removed and tested to specifications. If either opening or closing voltages are not within specifications, replace the solenoid.

PIPER SENECA II SERVICE MANUAL

11-40. **STARTING MOTOR SERVICE TEST SPECIFICATIONS.** Prestolite specifications for 12-volt cranking motors installed as standard equipment on the PA-34-200T are as follows:

TABLE XI-III. STARTING MOTOR SPECIFICATIONS

Motor Model	MCL-6501
Min. Brush Tension	32 oz. (With New
Max. Brush Tension	40 oz. Brushes)
No-Load Test (75° F):	
Volt	5
Max. Amps	65
Min. RPM	4900
Stall Torque:	
Max. Amps	410
Min. Torque, Ft.-Lbs.	8
Approx. Volts	2

PRESTOLITE S/M 1-12-71

11-41. BATTERY.

11-42. **SERVICING BATTERY.** The battery is located in the left forward portion of the nose section. It is enclosed in a fiberglass box with a vent system and a drain. The vents allow fresh air to enter the box and draw off fumes that may accumulate due to the charging process of the battery. The drain is clamped off from the bottom of the fuselage and should be opened occasionally to drain any accumulation of liquid or during cleaning of the box. The battery should be checked for fluid level but must not be filled above the baffle plates. A hydrometer check should be performed to determine the percent of charge in the battery. All connections must be clean and tight.

NOTE

Refer to note under paragraph 11-29 "Maintenance" when replacing cables in battery circuit.

11-43. REMOVAL OF BATTERY.

- a. Remove the access cover over nose wheel and battery in the nose baggage compartment.
- b. Disconnect the battery cables.

NOTE

Always remove the ground cable first and install last to prevent accidental short circuiting or arcing.

- c. Lift the battery from the box.

11-44. INSTALLATION OF BATTERY.

- a. Ascertain that the battery and battery box have been cleaned and are free of acid.
- b. Install the battery in box.
- c. Connect the positive lead to the positive battery terminal and secure.
- d. Connect the ground cable to the negative battery terminal and secure.
- e. Install access panel.

THIS SPACE INTENTIONALLY LEFT BLANK

PIPER SENECA II SERVICE MANUAL

11-45. **CHARGING BATTERY.** If the battery is not up to normal charge, remove the battery and recharge starting with a charging rate of 4 amperes and finishing with 2 amperes. A fast charge is not recommended.

TABLE XI-IV. HYDROMETER READING AND BATTERY CHARGE PERCENT

Hydrometer Reading	Percent of Charge
1280	100
1250	75
1220	50
1190	25
1160	Very little useful capacity discharged
1130 or below	

11-46. **BATTERY BOX CORROSION PREVENTION.** The battery should be checked for spilled electrolyte or corrosion at least each 50 hour inspection or at least every 30 days, whichever comes first. Should this be found in the box, on the terminals or around the battery, the battery should be removed and both the box and battery cleaned by the following procedure:

- a. Remove the box drain cap from the under side of the fuselage and drain off any electrolyte that may have overflowed into the box.
- b. Clean the battery and the box. Corrosion effects may be neutralized by applying a solution of baking soda and water mixed to a consistency of thin cream. The application of this mixture should be applied until all bubbling action has ceased.

CAUTION

Do not allow soda solution to enter battery.

- c. Rinse the battery and box with clean water and dry.
- d. As necessary, paint the battery box with an acid resistant paint. Allow paint to dry thoroughly.
- e. Place the cap over the battery box drain.
- f. Reinstall the battery.

11-47. **STARTING THROUGH EXTERNAL POWER RECEPTACLE WITH AIRPLANE'S BATTERY NEARLY DEPLETED.** The external power receptacle is built-in and located on the left side of the nose section on early models. On the later ones it can be installed per Piper Service Kit No. 761 085v.

NOTE

Should the hydrometer reading indicate less than 1190, the battery should be removed and recharged or replaced.

- a. When using a 12-volt battery for external power starting and the airplane's battery is nearly depleted, the following procedure should be used:
1. Disconnect the airplane's battery at the negative terminal to prevent excessive loading of the external starting battery.
 2. Check that all of the airplane's electrical equipment and master switch are turned off.
 3. Connect the external battery to the external power receptacle and start RIGHT ENGINE ONLY using normal starting procedures.
 4. Remove external battery and then reconnect airplane's battery at the negative terminal.
 5. Turn master switch on and check ammeter for battery charging current.
- b. When starting with a power cart and the airplane's battery is nearly depleted, the procedure in Step (a) need not be followed. The capacity of a power cart is sufficient to start an aircraft with a low battery. If a six-volt battery is available, it can be connected in series with the 12-volt external battery to supply 18-volts for starting. In this case, use the same starting procedure as used with a power cart.

CAUTION

If aircraft battery is weak, charging current will be high. Do not take off until charging current falls below 20 amps.

Never use a 12 or 24-volt battery in place of a six-volt battery since electrical damage may result.

11-48. LANDING AND TAXI LIGHTS. These lights consist of two 250 watt lamps which are located on a mounting fixture secured to the nose gear oleo strut housing. Both lamps are used for landing and one lamp is used while taxiing. Each lamp is controlled by a separate switch mounted on the switch panel. (Refer to Figure 11-1.) The lamps are wired to separate 10 amp circuit protectors mounted in the circuit protector panel. There is a safety switch mounted on the nose gear strut which will break the circuit to the lights when the nose gear is retracted in case the pilot forgets to turn the switches off.

11-49. REMOVAL OF LANDING AND TAXI LIGHTS. (Refer to Figure 11-21.)

- a. Ascertain the master switch is off prior to doing any work on the landing lights.
- b. Removal of either lamp from the landing light mounting fixture is accomplished by removing the screws securing the front lamp attachment plate and removing the attachment plate.

CAUTION

When removing the attachment plate, use caution not to drop the lamps.

- c. Disconnect the electrical leads from the lamp being removed.
- d. To remove the complete assembly from the gear strut, disconnect the electrical leads from both lamps and release the clamps that secure the assembly to the strut housing.

11-50. INSTALLATION OF LANDING AND TAXI LIGHTS. (Refer to Figure 11-21.)

- a. To install the landing lamps, attach the electrical leads to the lamp or lamps.
- b. Place the lamp or lamps against the mounting pad and position the attachment plate on the mounting fixture and secure with appropriate screws.

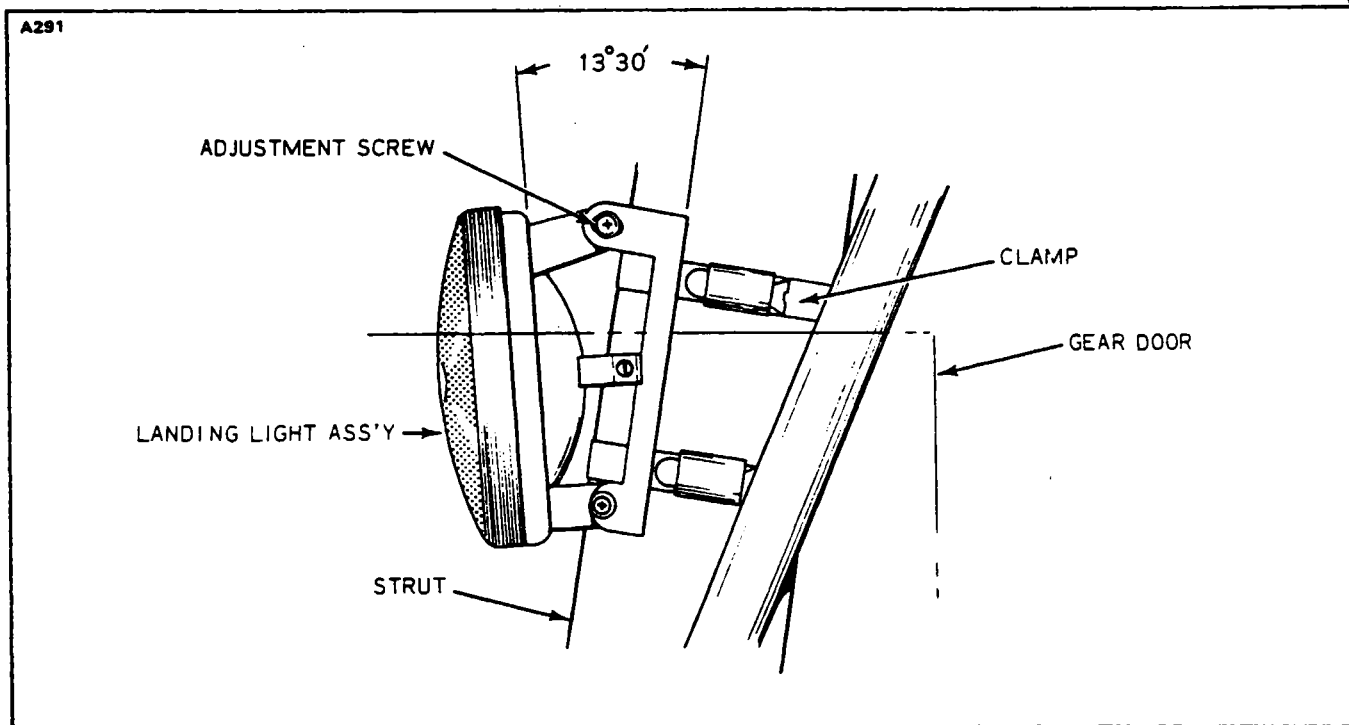

Figure 11-21. Landing Light Adjustment

CAUTION

Tighten the screws just enough to allow the lamps to fit snug in the mounting fixture.

- c. To install the landing light assembly to the strut, position the assembly against the strut housing with the bottom of the mounting fixture 2.9 inches up from the bottom of the strut housing. (Refer to Figure 11-21.)
- d. Align the bracket longitudinally and secure in place with clamps.
- e. The light beam angle may be adjusted by the adjustment screws at the sides of the bracket and tilting the mounting fixture as desired.

11-51. STALL WARNING SYSTEM. This system consists of an inboard and outboard lift detector, both of which are electrically connected to a stall warning horn located behind the instrument panel. The 1975 models also included a stall warning light with electrical connection per Figure 11-36. As stalling conditions are approached with the wing flaps up, the outboard lift detector will activate the warning system. As the flaps are lowered to the 25° and 40° position, a micro switch deactivates the outboard lift detector and activates the inboard lift detector which will now control the warning system should stall conditions exist. The electrical circuit for this system is protected by a 5 amp circuit protector located in the circuit protector panel. The stall warning system may be checked for proper operation by performing the following:

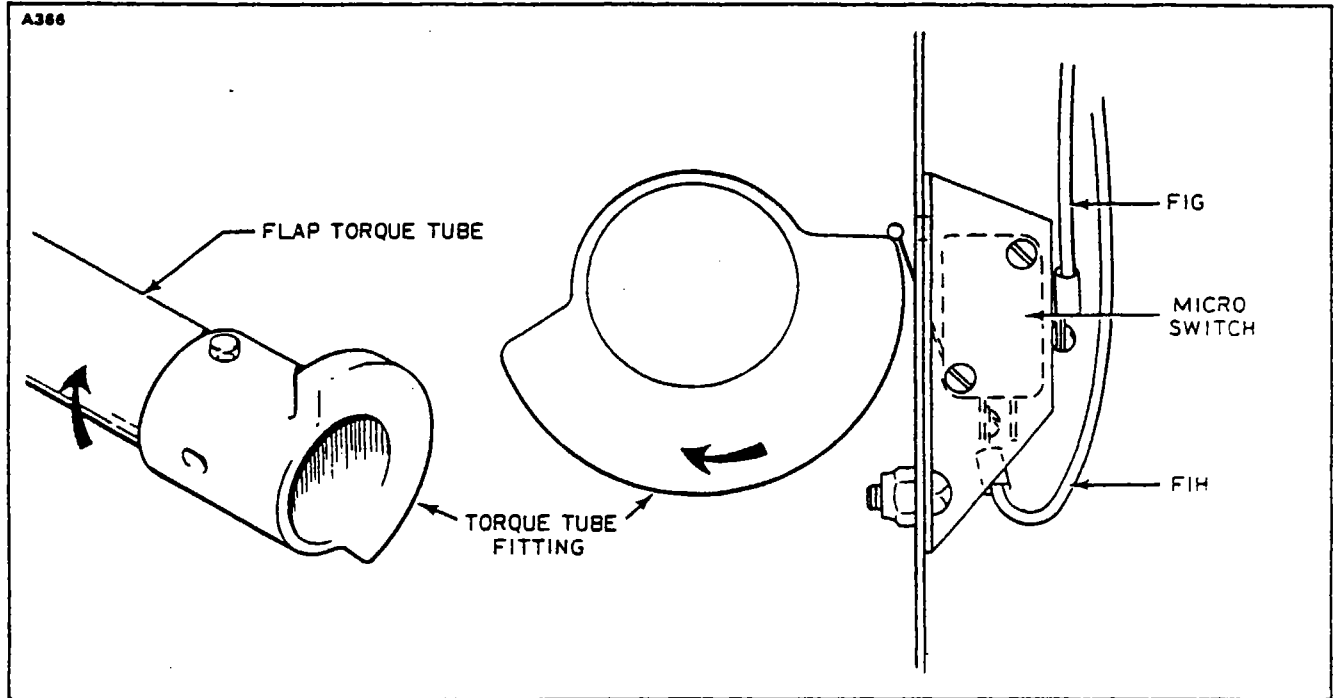

Figure 11-22. Adjusting Lift Detector Micro Switch

NOTE

To check the dual stall warning system, insert microswitch key under the leaf of the squat switch on the Left Main Gear.

a. Put the flaps in the full up position and turn on the master switch. Using finger pressure, gently raise the sensor blade of the outboard lift detector. The warning system should activate. Gently lowering the sensor blade should make the system deactivate. If light and horn are installed, ascertain that both operate.

b. With the flaps in the 25° and 40° down position and the master switch on, raise the sensor blade of the inboard lift detector. The warning system should activate. Gently lowering the sensor blade should make the system deactivate.

c. With the flaps in the 25° and 40° down position and the master switch on, raise the sensor blade of the outboard lift detector. The warning system should NOT activate. In the event the warning system does activate, the micro switch is in need of adjustment as follows:

NOTE

The master switch must be off prior to performing any work on the lift detector, warning light and horn or micro switch.

1. Refer to Section V, Paragraph 5-36 and proceed to the extent necessary to gain access to the micro switch mounted on a bracket adjacent to the left end of the wing flap torque tube. (Refer to Figure 11-22.)

2. Put the flaps in the full up position and determine that the wheel of the micro switch actuator is in contact with the torque tube fitting. Loosen, but do not remove the screws securing the micro switch in position. Move the flaps towards the full down position while moving the micro switch in the direction necessary to hear it actuate as the flaps assume the 25° down position. Tighten the micro switch mounting screws and repeat Steps a thru c.

11-52. REMOVAL OF LIFT DETECTOR.

- a. Remove four screws holding the unit in place and remove the unit from the wing.
- b. Identify the electrical leads to facilitate reinstallation and disconnect the electrical leads.

11-53. INSTALLATION OF LIFT DETECTOR.

- a. Attach electrical leads to the appropriate terminals of the lift detector.
- b. Position the unit on the wing, determining that the sensor blade of the unit drops down freely, and secure in position with four screws previously removed.

11-54. NAVIGATION LIGHTS.

11-55. REMOVAL OF WING NAVIGATION LIGHT.

- a. Remove screw securing the lens retainer.
- b. Remove lens and bulb.

NOTE

To remove the complete lamp assembly, the wing tip must be removed.

11-56. INSTALLATION OF WING NAVIGATION LIGHT.

- a. Install bulb, lens and lens retainer.
- b. Secure with appropriate screws.

11-57. REMOVAL OF TAIL NAVIGATION LIGHT.

- a. To remove bulb, remove the screws securing the light assembly to the rudder tip and remove the lens.
- b. Remove the bulb.

NOTE

To remove the complete light assembly, unsolder the electrical lead from the base of the light assembly and disconnect the remaining electrical lead at the connector.

11-58. INSTALLATION OF TAIL NAVIGATION LIGHT.

- a. Install bulb and lens in light assembly.
- b. Place light assembly in position on rudder tip and secure with appropriate screw.

11-58a. ANTI-COLLISION LIGHT.

11-59. REMOVAL OF LAMP IN ANTI-COLLISION WING TIP STROBE LIGHT. The lights are located in both wing tips next to the navigational lights.

- a. Remove the screw securing the navigational light cover and remove cover.
- b. Remove the three screws securing navigational light bracket assembly and remove light assembly.
- c. Remove the strobe lamp by cutting the wires on the lamp beneath the mounting bracket.
- d. Remove the defective lamp.
- e. Remove and discard the plug with the cut wires from the electrical socket.

11-60. INSTALLATION OF LAMP IN ANTI-COLLISION WING TIP STROBE LIGHT.

- a. Route the wires from the new lamp down through the hole in the navigational light bracket.
- b. Insert the wire terminals in the plastic plug supplied with the new lamp. Wire according to the schematic diagram located at the back of this section.
- c. Position strobe lamp on navigational light bracket.
- d. Secure navigational light assembly and bracket with appropriate screws.
- e. Install navigational light cover and secure with appropriate screws.

11-61. REMOVAL OF LAMP IN ANTI-COLLISION LIGHT. The light is located on the upper section of the vertical fin.

- a. Loosen the screw in the clamp securing the light cover.
- b. Remove the light cover.
- c. Remove the defective lamp from the socket.

11-62. TROUBLESHOOTING PROCEDURE FOR ANTI-COLLISION AND WING TIP STROBE LIGHT SYSTEMS. The strobe light assembly functions as a condenser discharge system. A condenser in the power supply is charged to approximately 450-volts D.C.; then discharged across the Xenon flash tube at intervals approximately 45 flashes per minute. The condenser is parallel across the Xenon flash tube which is designed to hold off the 450-volts D.C. applied until the flash tube is triggered by an external pulse. This pulse is generated by a solid state timing circuit in the power supply.

When troubleshooting the strobe light system, it must first be determined if the trouble is in the flash tube or the power supply. Replacement of the flash tube will confirm if the tube is defective. A normal operating power system will emit an audible tone of 1 to 1.5 KHz. If there is no sound emitted, check the system according to the following instructions. When troubleshooting the system, utilize the appropriate schematic at the back of this section.

- a. Ascertain the input voltage at the power supply is 14-volts.

CAUTION

When disconnecting and connecting the power supply input connections, do not get the connection reversed. Reversed polarity of the input voltage for just an instant will permanently damage the power supply. The reversed polarity destroys a protective diode in the power supply, causing self-destruction from overheating of the power supply. This damage is sometimes not immediately apparent, but will cause failure of the system in time.

- b. Check for malfunction in interconnecting cables.
 1. Ascertain pins 1 and 3 of interconnecting cable are not reversed.
 2. Using an ohmmeter, check continuity between pin 1 and 3 of interconnecting cable. If you obtain a reading on the meter, the cable is shorted and should be replaced.

PIPER SENECA II SERVICE MANUAL

NOTE

A short of the type described in Steps 1 and 2 will not cause permanent damage to the power supply but the system will be inoperative if such a short exists. Avoid any connection between pins 1 and 3 of the interconnecting cable as this will discharge the condenser in the power supply and destroy the trigger circuit.

CAUTION

When disconnecting the power supply, allow five minutes of bleed down time prior to handling the unit.

- c. Check interconnecting cables for shorts.
 - 1. Disconnect the output cables from the power supply outlets.
 - 2. The following continuity checks can be made with an ohmmeter.
 - 3. Check for continuity between the connectors of each interconnecting cable by checking from pin 1 to pin 1, pin 2 to pin 2, and pin 3 to pin 3. When making these checks if no continuity exists, the cable is broken and should be replaced.
 - 4. Check continuity between pins 1 and 2, 1 and 3, and 2 and 3 of the interconnect cable. If continuity exists between any of these connections, the cable is shorted and should be replaced.
 - 5. Check for continuity from pins 1, 2 and 3 to airplane ground. If continuity exists, the cable is shorted and should be replaced.
- d. Check the tube socket assembly for shorts.
 - 1. Disconnect the tube socket assembly of the anti-collision light from the interconnecting cable.
 - 2. The following continuity checks can be made with an ohmmeter.
 - 3. Check for continuity between pin 1 of AMP connector to pin 1 of tube socket, pin 2 of AMP connector to pins 6 and 7 of tube socket and pin 3 of AMP connector to pin 4 of tube socket. When making these tests if no continuity exists, the tube socket assembly is broken and should be replaced.

11-63. INSTALLATION OF ANTI-COLLISION LIGHT.

- a. Plug in new lamp using correct number.
- b. Replace light cover.
- c. Tighten screw in clamp to secure light cover.

11-63a. READING LIGHTS.

11-64. REMOVAL OF LAMP IN OVERHEAD READING LIGHTS. The lights are located in the center and rear overhead panels.

- a. Grasp the protruding section of the light assembly and turn to remove from its socket.
- b. Remove the lamp from the light assembly mounting fixture.

11-65. INSTALLATION OF LAMP IN OVERHEAD READING LIGHTS.

- a. Insert the new lamp using the proper number in the light assembly mounting fixture.
- b. Install the mounting fixture in the light assembly and turn to secure.

11-66. INSTRUMENT AND PANEL LIGHTS. The instrument and panel lights are broken up into six groups: Main Panel Lights, Copilot Panel Lights, Lower Panel Lights, Overhead Panel Flood Lights, Middle Panel Lights and the Engine Instrument Cluster Lights. The instrument lights are controlled by a 5 amp circuit breaker through a transistorized dimmer. The dimmer control is located in the middle of the instrument panel just above the pedestal. In earlier model airplanes, there is one control knob connected to a variable resistor that controls the intensity of the instrument lights. There is a second control knob connected to a variable resistor which controls the light intensity for all the avionic equipment. The overboost warning lights on the annunciator panel are dimmed when the instrument lights are dimmed. It may be necessary to gain access to the Dimmer Control Assembly, if so, follow the instructions given below.

11-67. REMOVAL OF DIMMER CONTROL ASSEMBLY.

- a. Access to the Dimmer Control Assembly is from beneath the instrument panel.
- b. Disconnect the electrical connection from the assembly.
- c. Remove the knob from panel front.
- d. Remove the two screws securing the assembly to the instrument panel.
- e. Remove assembly from the airplane.

11-68. INSTALLATION OF DIMMER CONTROL ASSEMBLY.

- a. Position the assembly in the instrument panel with the control knobs inserted into their appropriate slots.
- b. Secure the assembly to the instrument panel with the two screws previously removed.
- c. Connect the electrical connection to the assembly.
- d. Check operation of Dimmer Control Assembly.

11-69. ANNUNCIATOR PANEL.

11-70. DESCRIPTION. The annunciator panel is a light cluster mounted in the upper left instrument panel that provides a visual indication of individual system malfunctions by the illumination of a warning light. A push-to-test switch on the left side of the annunciator is used to illuminate the entire display to check the condition of the lights when the engine is running. The gyro air, alt and oil lights will work when the engine is not running with the master switch on. Power to the annunciator is supplied from the bus bar through a 5 amp fuse located behind the left exhaust gas temperature gauge.

The left and right OVER BST. lights are activated whenever the left or right engine manifold pressure exceeds 39.5 inches of mercury. The manifold pressure sensor is incorporated in the manifold pressure gauge.

The OIL warning light is activated by a pressure sensor in the oil pressure line to the oil pressure gauge whenever the engine oil pressure drops below 30 psi. The sensor is mounted in a special bulkhead T fitting on the aft side of the fire wall.

The GYRO AIR warning light is activated by a pressure sensor mounted in the gyro pressure regulator on the aft side of the fire wall. The switch will activate when the gyro air pressure is below 4.5 inches of mercury.

The ALT warning light is activated whenever one or both alternator output circuits fail.

11-71. ANNUNCIATOR LIGHTS TEST

PPS40057

NOTE

The sequence of the following tests may be varied at the option of the mechanic.

- a. Press the annunciator test button to insure that all annunciators illuminate.
- b. Start the right engine, operate at 700-1000 RPM and note that the oil and air pressure are normal.
- c. Start the left engine and note that the GYRO AIR light goes out as the engine starts. Note that the oil pressure is normal and that the alternator has output.
- d. Idle one engine at a time while carefully observing its oil pressure gauge to insure that the OIL annunciator light comes on at 15 psi.

NOTE

The mixture control can be moved to cut-off, then to rich in order to get lower then normal idle speeds.

- e. With both engines at approximately 900 RPM place one alternator in the off position at a time. Check that either or both alternator switches in the off position causes the ALT annunciator to illuminate.
- f. Use proper caution to insure that the propellers are over hard surface and that the propeller blast will do no damage, then run up the engines one at a time to check that each OVERBST annunciator comes on at 39.5 ± 0.5 inches of mercury manifold pressure.
- g. Shut down the right engine first and check that the GYRO AIR illuminates just as the engine slows to approximately 300 RPM. Check that the other annunciator lights are on.
- h. Shut down left engine.

11-72. TROUBLESHOOTING (Refer to Table XI-V.)

TABLE XI-V. TROUBLESHOOTING CHART (ELECTRICAL SYSTEM)

Trouble	Cause	Remedy
<u>ANNUNCIATOR PANEL</u>		
All the warning lights fail to operate.	Blown fuse. No current from bus.	Replace the 5 amp fuse behind instrument panel. Check all wire segments, connections, and the receptacle at the left side of the annunciator panel.
All the warning lights fail to extinguish after engine is running.	Test switch grounded out.	Check terminals and replace switch if necessary.
Oil or gyro air warning light fails to extinguish.	Sensor activates at too high a setting. Sensor terminals bridged. Defective sensor.	Replace. Remove material between terminals. Replace.
Oil or gyro air warning light fails to operate.	Lamp burned out. No current to sensor. Sensor activates at too low a setting. Defective sensor.	Replace. Check all wire segments and connections. Replace. Replace.

PIPER SENECA II SERVICE MANUAL

TABLE XI-V. TROUBLESHOOTING CHART (ELECTRICAL SYSTEM) (cont.)

Trouble	Cause	Remedy
<u>ANNUNCIATOR PANEL (cont.)</u>		
Overboost warning light fails to extinguish.	Manifold pressure gauge sensors set too low.	Check sensor activation. Sensors should activate at 39.5 inches of mercury.
Overboost warning light fails to activate.	Lamp burned out. Defective sensor switches.	Replace. Check and replace if necessary.
Alternator warning light fails to operate.	Lamp burned out.	Replace.
Alternator warning light fails to extinguish.	Blown fuse or fuses. Defective alternator output circuit.	Replace one or both 5 amp fuses behind instrument panel. Check and repair.
Test switch fails to activate warning lights.	Bad switch or connections.	Check wires and replace switch if necessary.

TABLE XI-V. TROUBLESHOOTING CHART (ELECTRICAL SYSTEM) (cont.)

Trouble	Cause	Remedy
<p>Zero output indicated on ammeter regardless of RPM (refer to alternator system test procedure).</p>	<p style="text-align: center;"><u>ALTERNATOR</u></p> <p>Open field circuit.</p>	<p>With master switch turned on check for battery voltage (12V) from ship's main bus through entire field circuit to alternator field terminal. Measure voltage from ground (-) to the following points (+) in sequence: bus bar, output circuit diodes, field circuit breaker (5A), field terminals of master switch, voltage regulator and alternator field terminal.</p> <p>Interruption of voltage through any of these points isolates the faulty component or wire which must be replaced. (See Figure 11-23.)</p>
	<p>Open output circuit.</p>	<p>With master switch turned on check for battery voltage (12V) from ship's main bus through entire output circuit to alternator battery post. Measure voltage from ground (-) to the following points (+) in sequence: bus bar, output circuit diodes, ammeter, and alternator battery post.</p>

TABLE XI-V. TROUBLESHOOTING CHART (ELECTRICAL SYSTEM) (cont.)

Trouble	Cause	Remedy
<p>Zero output indicated on ammeter regardless of RPM (refer to alternator system test procedure). (cont)</p>	<p><u>ALTERNATOR (cont)</u></p> <p>Open output circuit. (cont)</p> <p>Open field winding in alternator.</p>	<p>Interruption of voltage through any of these points isolates the faulty component or wire which must be replaced. (See Figure 11-23.)</p> <p>Disconnect field terminal of alternator from field wiring and check for continuity from field terminal to ground with ohmmeter (20-100 ohms) depending on brush contact resistance. (Pull propeller slowly by hand turning alternator rotor through 360° of travel.)</p> <p>CAUTION</p> <p>Turn magneto switch to off before turning prop.</p> <p>If resistance is high check brushes for spring tension and excessive wear and replace if necessary. If brushes are okay and field reads open, replace alternator.</p>

TABLE XI-V. TROUBLESHOOTING CHART (ELECTRICAL SYSTEM) (cont.)

Trouble	Cause	Remedy
<p>Output indicated on ammeter does not meet minimum values specified in alternator system test procedure.</p>	<p><u>ALTERNATOR (cont)</u></p>	
	<p>Faulty voltage regulator.</p>	<p>Start engine, turn on load (ref. alternator test procedure), set throttle at 2300 RPM. Check voltage at bus bar (convenient check point, remove cigar lighter and check from center contact (+) to ground (-). Voltage should be 13.5 volts minimum. If voltage is below this value replace regulator.</p>
	<p>High resistance connections in field or output circuit.</p>	<p>Check visually for loose binding posts at the various junction points in system, alternator battery post, lugs on ammeter, connections at voltage regulator, circuit breaker, etc., (See Figure 1-23.) Examine crimped terminal ends for signs of deterioration at crimp or strands of broken wire at crimp. Tighten any loose binding posts or replace bad wire terminals.</p>
<p>Open rectifier.</p>	<p>If any of the six rectifiers pressed into the rear bell housing of the alternator open up internally it will result in a definite limitation on the current that can be drawn from the alternator. After having checked the previous</p>	

PIPER SENECA II SERVICE MANUAL

TABLE XI-V. TROUBLESHOOTING CHART (ELECTRICAL SYSTEM) (cont.)

Trouble	Cause	Remedy
Output indicated on ammeter does not meet minimum values specified in alternator system test procedure. (cont)	<p style="text-align: center;"><u>ALTERNATOR (cont)</u></p> <p>Open rectifier.</p>	causes of low output it can be assumed that a faulty rectifier exists and replacement of the rectifier is recommended.
Field circuit breaker trips.	Short circuit in field circuit.	Disconnect field wiring at terminal of alternator. Turn on master switch. If breaker continues to trip, proceed to disconnect each leg of field circuit, working from the alternator towards the circuit breaker until breaker can be reset and will hold. Replace component or wire which was isolated as defective. (See Figure 11-23.)
	Short circuit in field winding of alternator.	<p>Disconnect field wiring at terminal of alternator. Turn on master switch. Reset breaker and if breaker fails to retrip, this isolates short circuit to field of alternator itself. Check brush holders for shorting against frame. If there are no obvious signs of a physical short circuit at field terminal or brush holder, replace alternator. (Note: Intermittent short circuit.)</p> <p>Internal short circuiting of the field can occur at various positions of the rotor, therefore, re-</p>

TABLE XI-V. TROUBLESHOOTING CHART (ELECTRICAL SYSTEM) (cont.)

Trouble	Cause	Remedy
Field circuit breaker trips. (cont)	<p><u>ALTERNATOR (cont)</u></p> <p>Short circuit in field winding of alternator.</p>	<p>connect field, reset breaker, pull propeller slowly by hand turning alternator rotor through 360° of travel. Observe circuit breaker for signs of tripping.</p> <p>CAUTION</p> <p>Turn magneto switch to off before turning propeller.</p>
Output circuit defective.	Short circuit in output circuit.	Disconnect wiring at battery post of alternator. Turn on master switch. Disconnect each leg of output circuit, working from the alternator towards the bus bar. Replace component or wire which was isolated as defective. (See Figure 11-23.)

PIPER SENECA II SERVICE MANUAL

TABLE XI-V. TROUBLESHOOTING CHART (ELECTRICAL SYSTEM) (cont.)

Trouble	Cause	Remedy
<p>Output circuit defective. (cont.)</p>	<p>ALTERNATOR (cont)</p> <hr/> <p>Battery installed with reversed polarity.</p> <p>Battery charged backwards.</p>	<p>Remove battery and reinstall with correct polarity.</p> <p>Remove battery. Connect load such as landing light lamp or similar load and discharge battery. Recharge with correct polarity and test each cell for signs of damage due to reversed charging.</p> <p>NOTE</p> <p>This type of condition can only occur in a case where a discharged battery has been removed from the airplane and put on a charger with the polarity reversed. This reversal in polarity cannot occur in the airplane due to any fault in the alternator system.</p>
<p>Excessive ammeter fluctuation.</p>	<p>Defective voltage regulator.</p> <p>Excessive resistance in field circuit.</p>	<p>Replace voltage regulator.</p> <p>Check all connections and wire terminals in field circuit for deterioration such as loose binding posts, broken wire strands at terminals, etc. Tighten all connections and replace faulty terminals.</p>

TABLE XI-V. TROUBLESHOOTING CHART (ELECTRICAL SYSTEM) (cont.)

Trouble	Cause	Remedy
<p>Starter fails to operate.</p>	<p style="text-align: center;"><u>STARTER</u></p> <p>Low battery charge.</p> <p>Defective or improper wiring or loose connections.</p> <p>Defective starter solenoid or control switch.</p> <p>Binding, worn, or improperly seated brush, or brushes with excessive side play.</p>	<p>Check and recharge if necessary.</p> <p>Refer to electrical wiring diagram and check all wiring.</p> <p>Replace faulty unit.</p> <p>Brushes should be a free fit in the brush boxes without excessive side play. Binding brushes and brush boxes should be wiped clean with a gasoline (undoped) moistened cloth. A new brush should be run in until at least 50 percent seated; however, if facilities are not available for running in brushes, then the brush should be properly seated by inserting a strip of number 000 sandpaper between the brush and commutator, with the sanded side next to the brush. Pull sandpaper in the direction of rotation, being careful to keep it in the same contour as the commutator.</p>

PIPER SENECA II SERVICE MANUAL

TABLE XI-V. TROUBLESHOOTING CHART (ELECTRICAL SYSTEM) (cont.)

Trouble	Cause	Remedy
<p>Starter fails to operate. (cont)</p>	<p>STARTER (cont.)</p> <hr/> <p>Binding worn, or im- properly seated brush or brushes with ex- cessive side play.</p> <p>Dirty commutator.</p> <p>Shorted, grounded, or open armature.</p> <p>Grounded or open field circuit.</p>	<p>CAUTION</p> <p>Do not use coarse sandpaper or emery cloth. After seating, clean thoroughly to remove all sand and metal particles to prevent excessive wear. Keep motor bearing free from sand or metal par- ticles.</p> <p>If commutator is rough or dirty, smooth and polish with number 0000 sandpaper. If too rough and pitted, re- move and turn down. Blow out all particles.</p> <p>Remove and replace with an armature known to be in good condition.</p> <p>Test, repair if possible or replace with a new part.</p>
<p>Low motor and crank- ing speed.</p>	<p>Worn, rough, or im- properly lubricated motor or starter gearing.</p> <p>Same electrical causes as listed under "Motor fails to operate."</p>	<p>Disassemble, clean, in- spect, and relubricate, replacing ball bearings if worn.</p> <p>Same remedies listed for these troubles.</p>
<p>Excessive arcing of motor brushes.</p>	<p>Binding, worn, or im- properly seated brush or brushes with ex- cessive side play.</p>	<p>See information above dealing with this trouble.</p>

PIPER SENECA II SERVICE MANUAL

TABLE XI-V. TROUBLESHOOTING CHART (ELECTRICAL SYSTEM) (cont.)

Trouble	Cause	Remedy
	<u>STARTER (cont)</u>	
Excessive arcing of motor brushes. (cont)	Dirty commutator, rough, pitted or scored.	Clean as outlined above.
Excessive wear and arcing of motor brushes.	Rough or scored commutator.	Remove and turn commutator down on a lathe.
	Armature assembly not concentric.	Reface commutator.
	<u>BATTERY</u>	
Discharged battery.	Battery worn out.	Replace battery.
	Low electrical system voltage.	Check voltage regulator voltage.
	Standing too long.	Remove and recharge battery if left in unused airplane 3 weeks or more.
	Equipment left on accidentally.	Remove and recharge.
	Impurities in electrolyte.	Replace.
	Short circuit (ground) in wiring.	Check wiring.
	Broken cell partitions.	Replace.
Battery life is short.	Overcharge due to level of electrolyte being below top of plates.	Maintain electrolyte.
	Sulfation due to disuse.	Replace.
	Impurities in electrolyte.	Replace battery.
	Low charging rate.	Check voltage regulator voltage.

Reissued: 10/11/79

PIPER SENECA II SERVICE MANUAL

TABLE XI-V. TROUBLESHOOTING CHART (ELECTRICAL SYSTEM) (cont.)

Trouble	Cause	Remedy
Cracked cell jars.	<u>BATTERY (cont)</u> Hold-down bracket loose.	Replace battery and tighten.
	Frozen battery.	Replace.
Compound on top of battery melts.	Charging rate too high.	Reduce charging rate. Check voltage regulator voltage.
Electrolyte runs out of vent plugs.	Too much water added to battery and charging rate too high.	Drain and keep at proper level and check voltage regulator voltage.
Excessive corrosion inside container.	Spillage from over-filling.	Use care in adding water.
	Vent lines leaking or clogged.	Repair or clean.
	Charging rate too high.	Adjust voltage regulator.
Battery freezes.	Discharged battery.	Replace.
	Water added and battery not charged immediately.	Always recharge battery for 1/2 hour following addition of water in freezing weather.
Leaking battery jar.	Frozen.	Replace.
Battery polarity reversed.	Connected backwards on airplane or charger.	Battery should be slowly discharged completely and then charged correctly and tested.
Battery consumes excessive water.	Charging rate too high (if in all cells).	Correct charging rate.
	Cracked jar (one cell only).	Replace battery.

PIPER SENECA II SERVICE MANUAL

TABLE XI-VI. LAMP REPLACEMENT GUIDE

Location	Piper Part No.	Lamp No.
Wing Tips	751 381	1512
Taillight	753 431	1073
Anti-Collision	757 635	A406
Landing Light	472 661	4509
Reading Light		93
Compass Light	472 054	330
Forward Baggage	472 036	89
Stall Warning	572 054	330
Instrument Cluster		53
Gear – Down	472 054	330
Gear – Up	472 054	330
Annunciator Panel	472 054	330
Instrument Panel	472 072	26

PIPER SENECA II SERVICE MANUAL

TABLE XI-VII. ELECTRICAL WIRE CODING

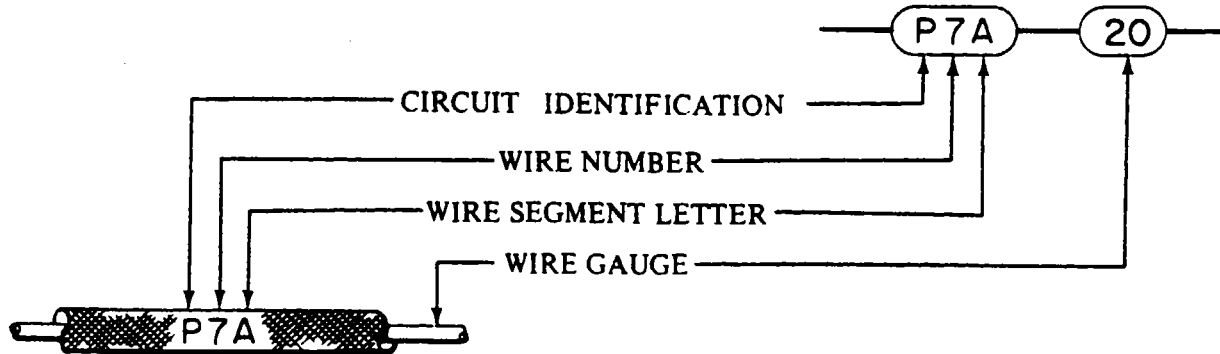

CIRCUIT FUNCTION LETTER	CIRCUITS	HARNESS CONNECTOR NUMBER'S AND LOCATIONS
A	AUTOPILOT	E 100 Series = Left Wing and Nacelle.
C	CONTROL SURFACE	E 200 Series = Right Wing and Nacelle.
E	ENGINE INSTRUMENT	E 300 Series = Aft Fuselage
F	FLIGHT INSTRUMENT	E 400 Series = Forward Fuselage
G	LANDING GEAR	
H	HEATER - VENTILATING & DEICING	
L	LIGHTING	
P	POWER	
Q	FUEL & OIL	
RP	RADIO POWER	
RG	RADIO GROUND	
RZ	RADIO AUDIO & INTERPHONE	
J	IGNITION	
W	WARNING	
K	STARTER	

TABLE XI-VIII. ELECTRICAL SYMBOLS

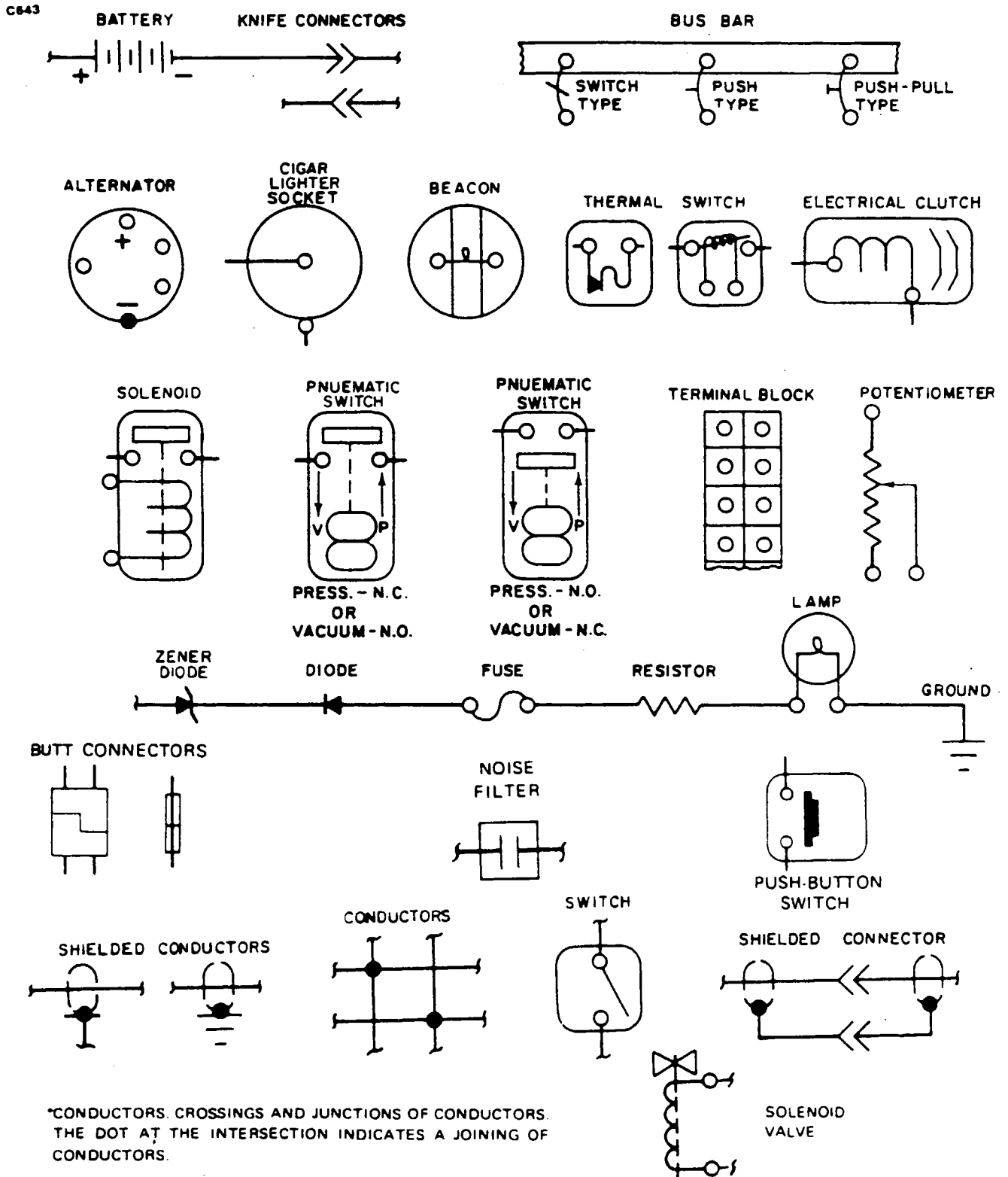

Revised: 11/12/82

PIPER SENECA II SERVICE MANUAL

TABLE XI-IX. ELECTRICAL SYSTEM COMPONENT LOADS

Duty Cycle		Equipment	Circuit Breaker	Load (Amps)	Optional
Cont.	Inter.				
X		Alternator Field (2)	5	5.0	
		Anti-Collision (Strobe)	10	4.4	
	X	Cabin Lights (4)	10	4.0	
	X	Cigar Lighter	10	8.0	
	X	Combustion Heater	15	13.0	
	X	Defroster Blower	10	3.0	
	X	Electric Pitch Trim	5	5.0	
	X	Fuel Pump (2)	5	10.0	
	X	Heated Windshield	15	13.8	X
	X	Hydraulic Pump	25	25.0	
X		Instrument Lights	5	3.0	
	X	Landing Lights (2)	10	8.0	
X		Master Contactor	-	0.6	
	X	Pitot Heat	15	13.2	
X		Position Lights	5	4.0	
	X	Prop Deice		20.0	X
		Red Flood Lights	5	5.0	
	X	Stall Warning Cluster	5	1.0	
	X	Stall Warning Heat		7.5	X
	X	Starter		175.0	
	X	Starter Solenoid	10	10.0	
X		Turn & Bank	5	0.5	

PIPER SENECA II SERVICE MANUAL

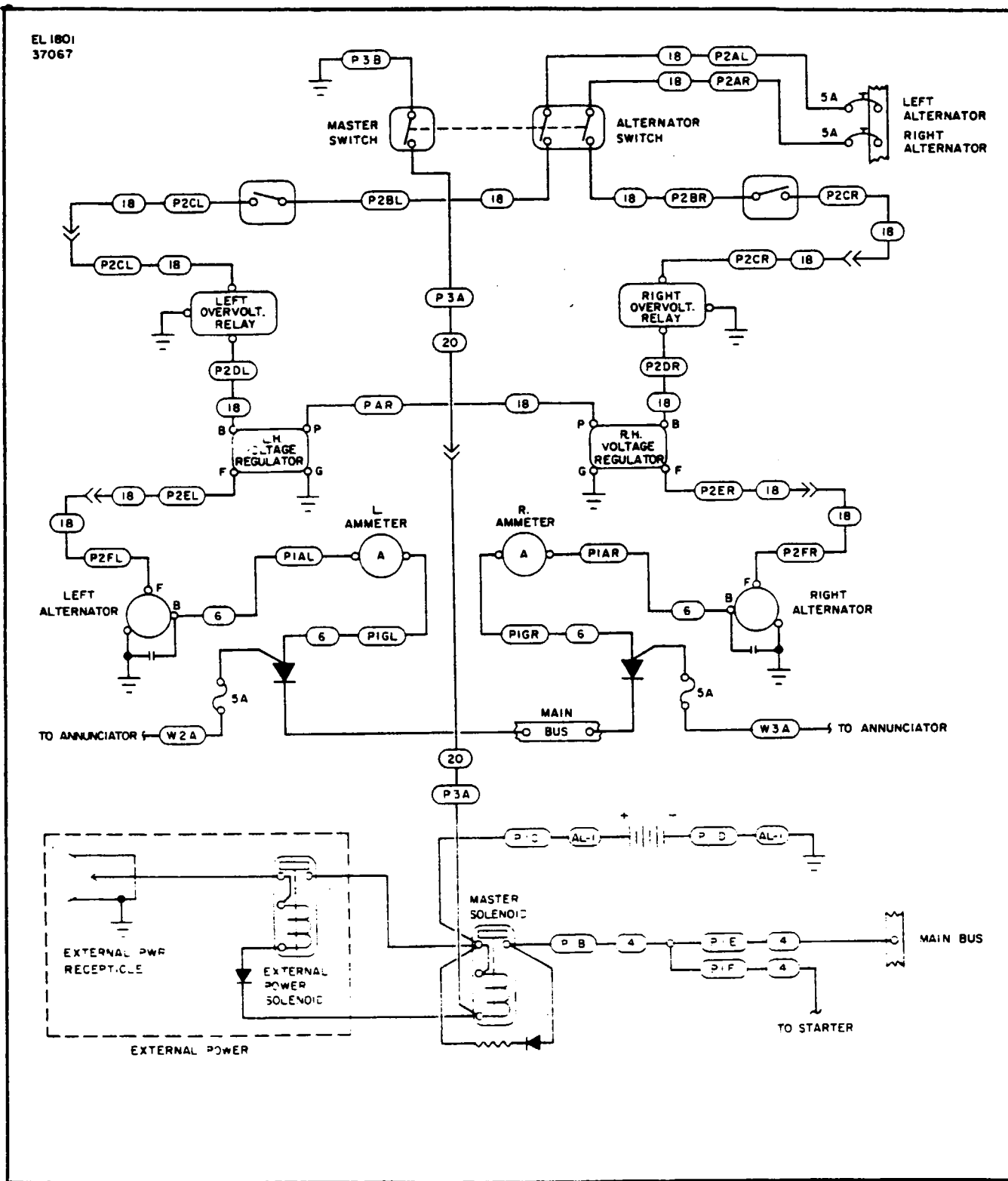

Figure 11-23. Alternator, S/N 34-7570001 to 34-7570337

PIPER SENECA II SERVICE MANUAL

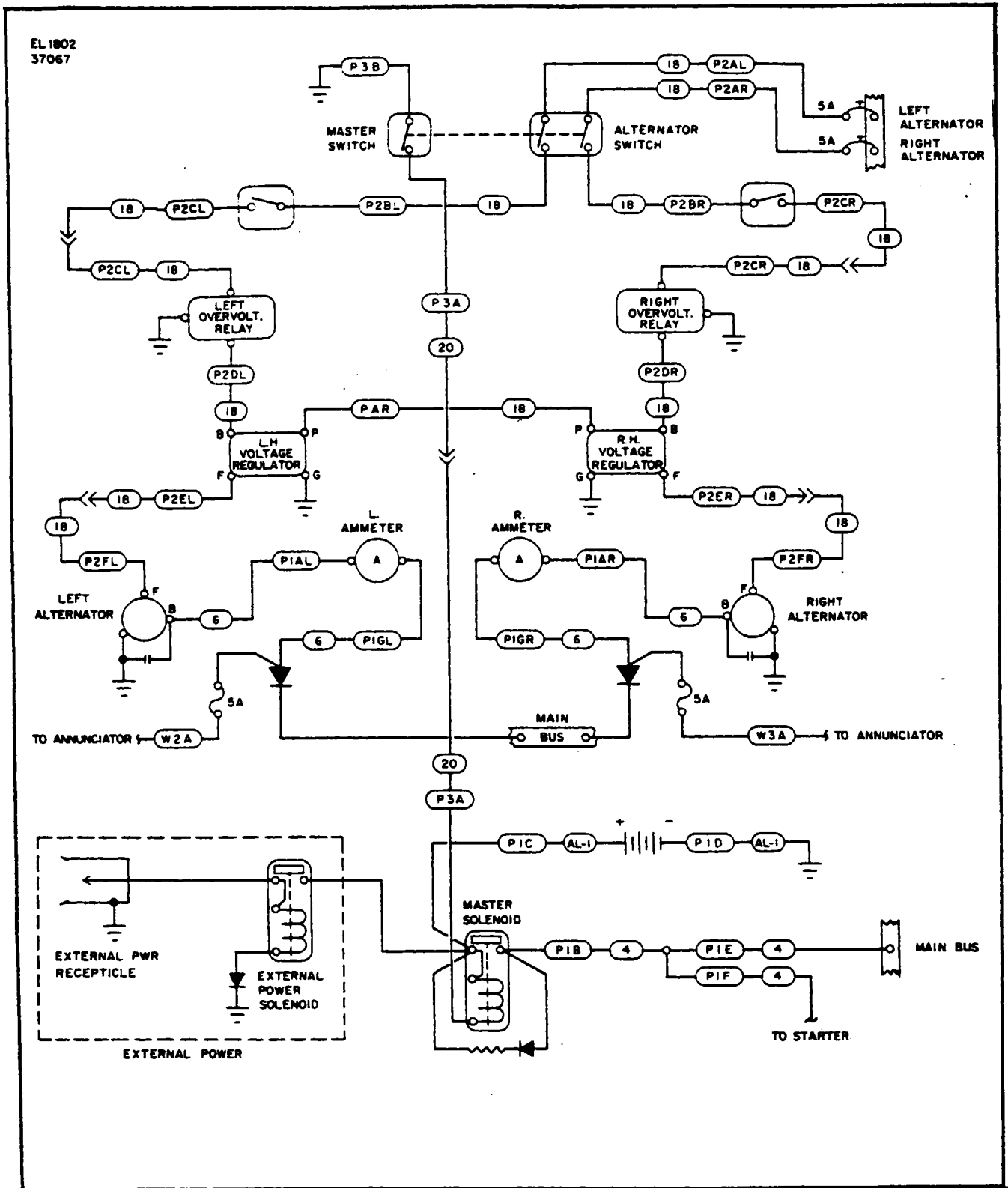

Figure 11-24. Alternator, S/N 34-7670001 to 34-7670393

PIPER SENECA II SERVICE MANUAL

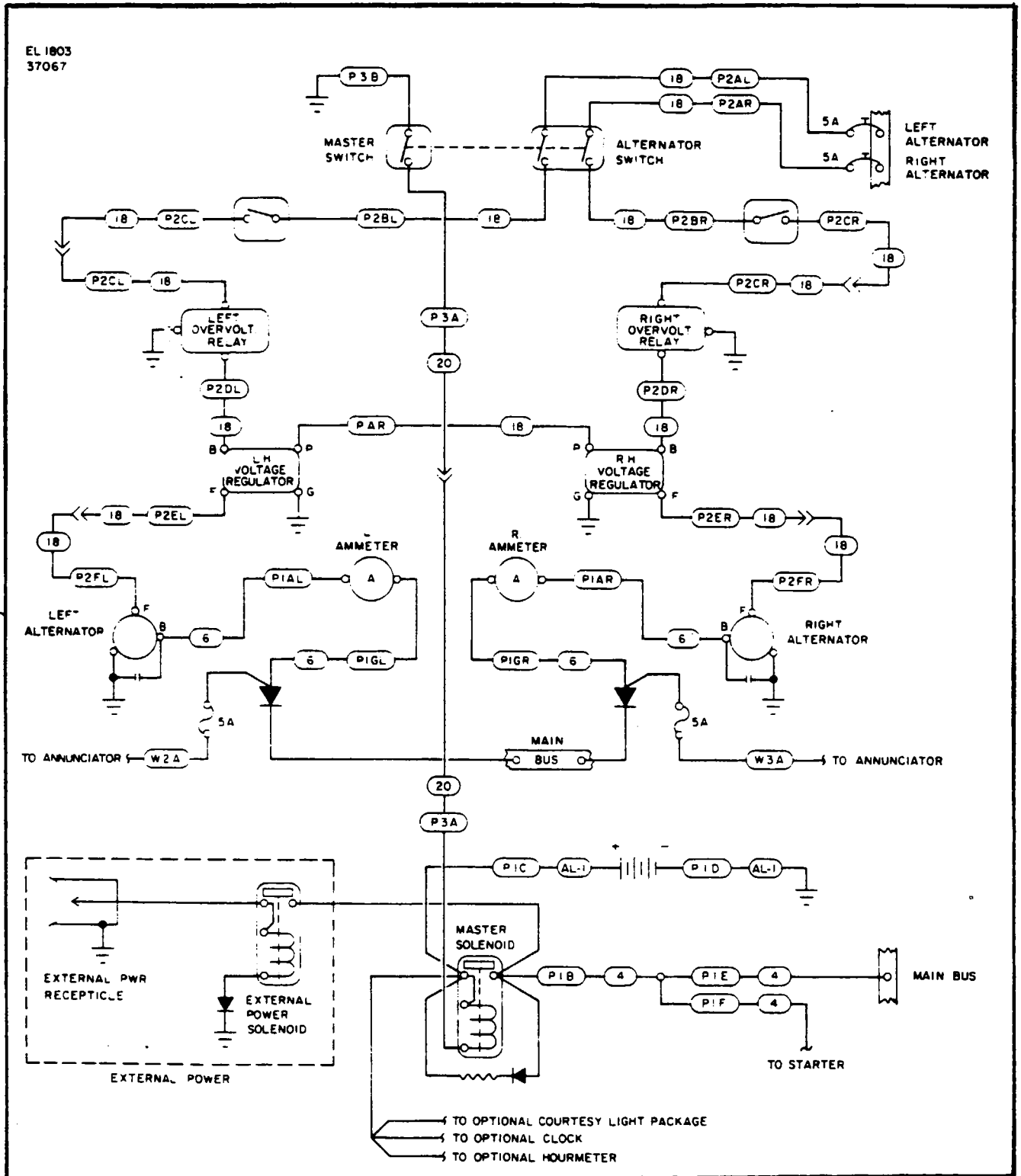

Figure 11-25. Alternator, S/N 34-7770001 and up

Revised: 11/12/82

ELECTRICAL SYSTEM

PIPER SENECA II SERVICE MANUAL

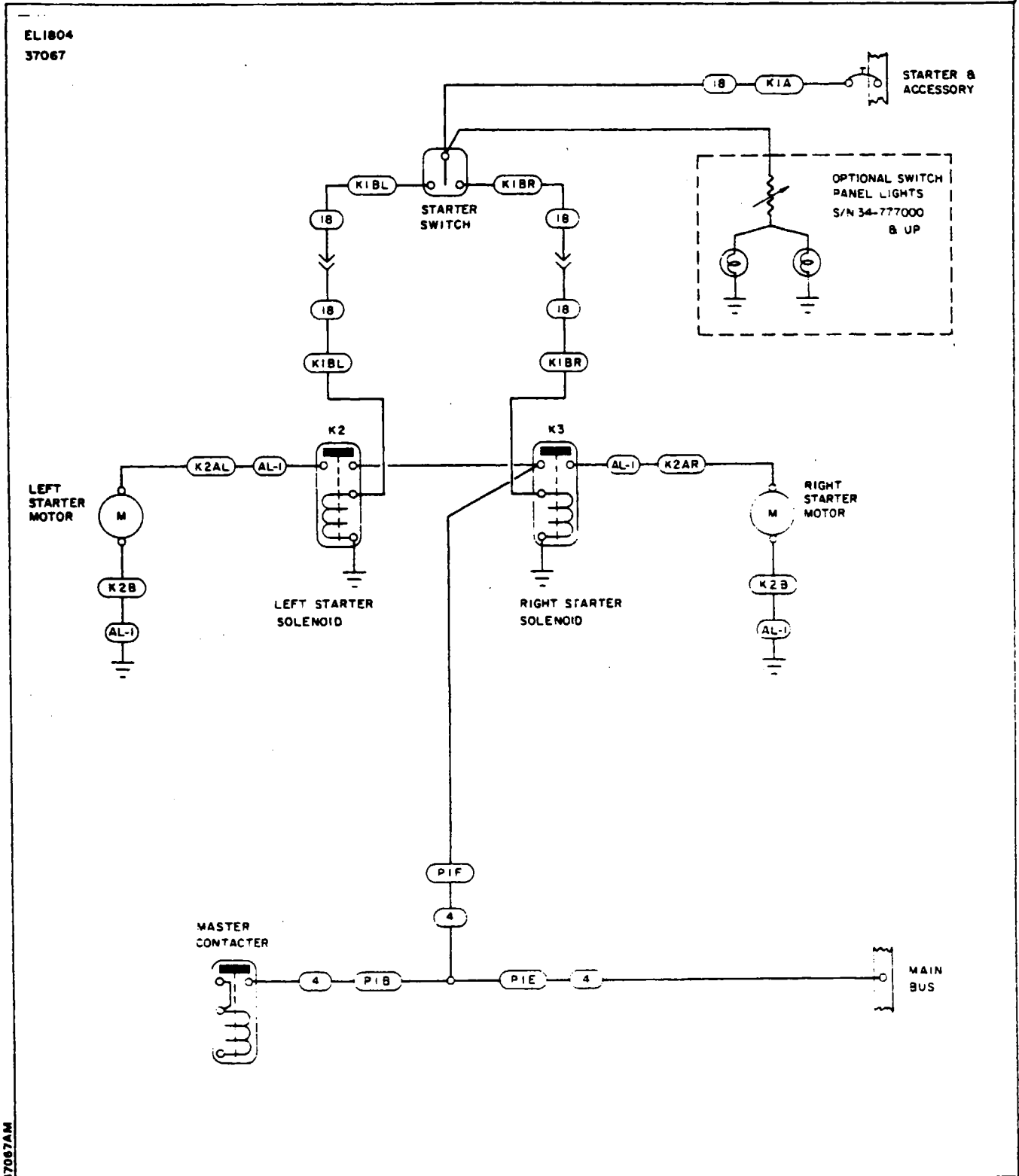

Figure 11-26. Starters, S/N 34-7570001 and up

Revised: 11/12/82

ELECTRICAL SYSTEM

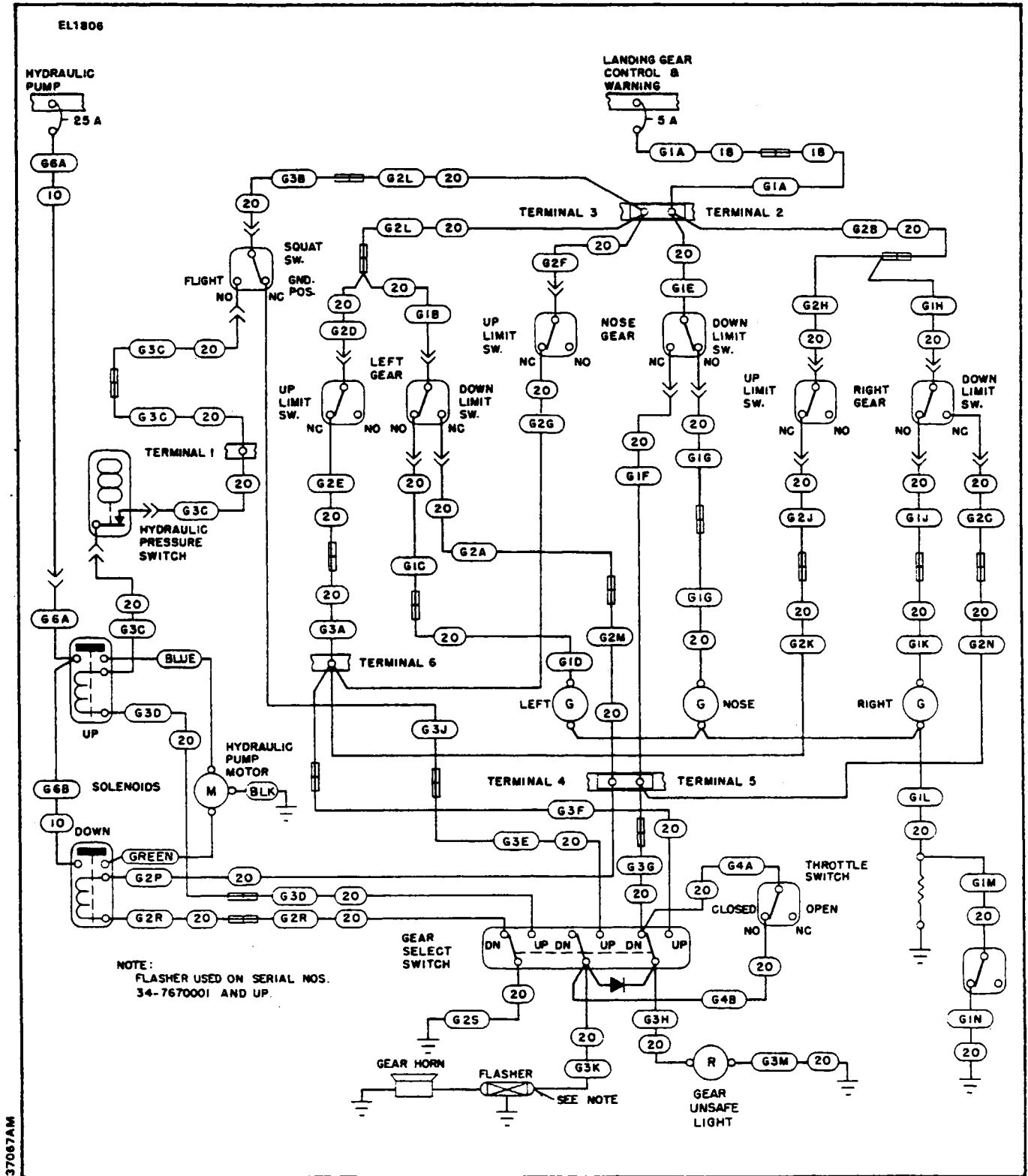

Figure 11-27. Landing Gear

PIPER SENECA II SERVICE MANUAL

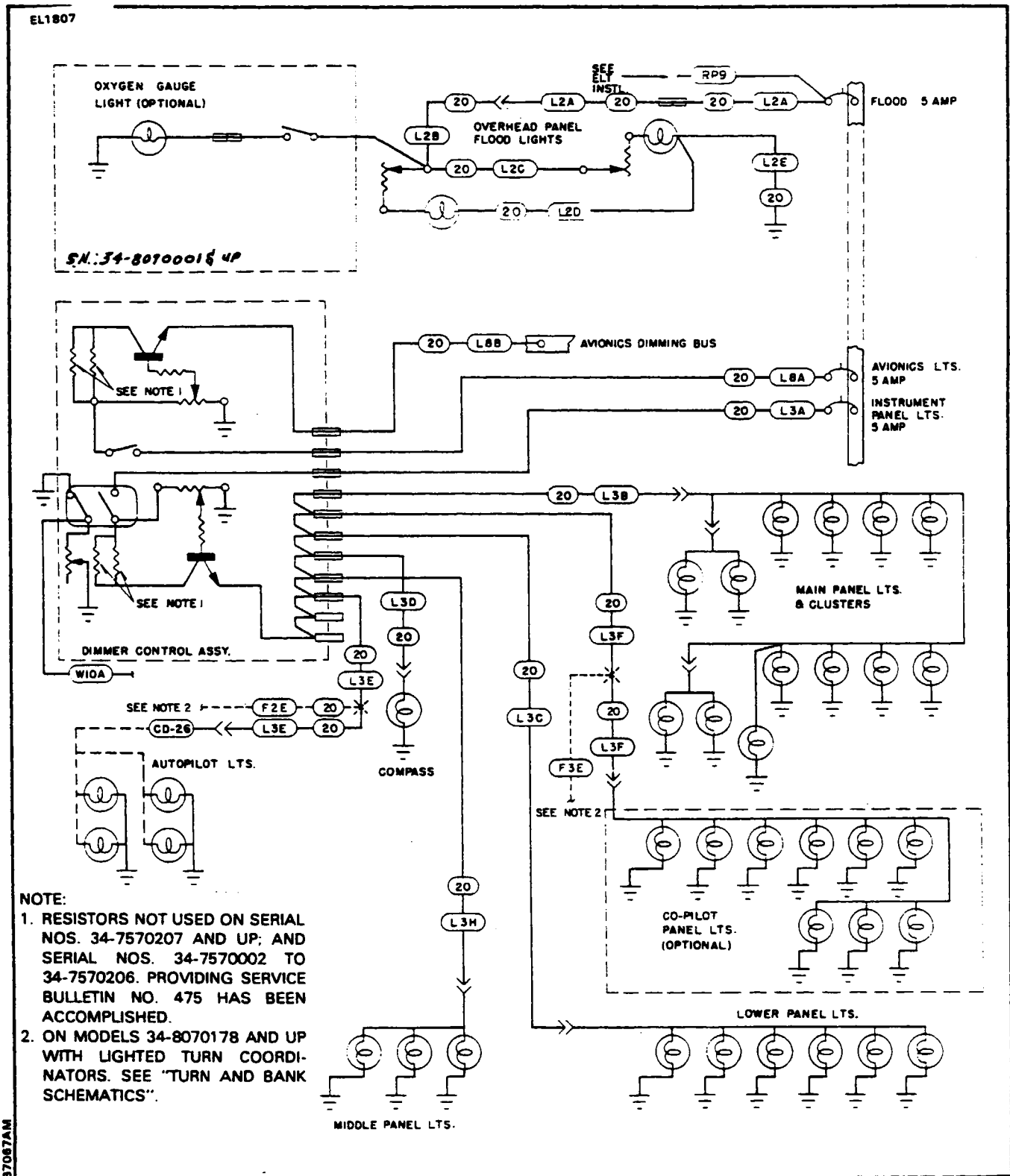

Figure 11-28. Panel Lighting

PIPER SENECA II SERVICE MANUAL

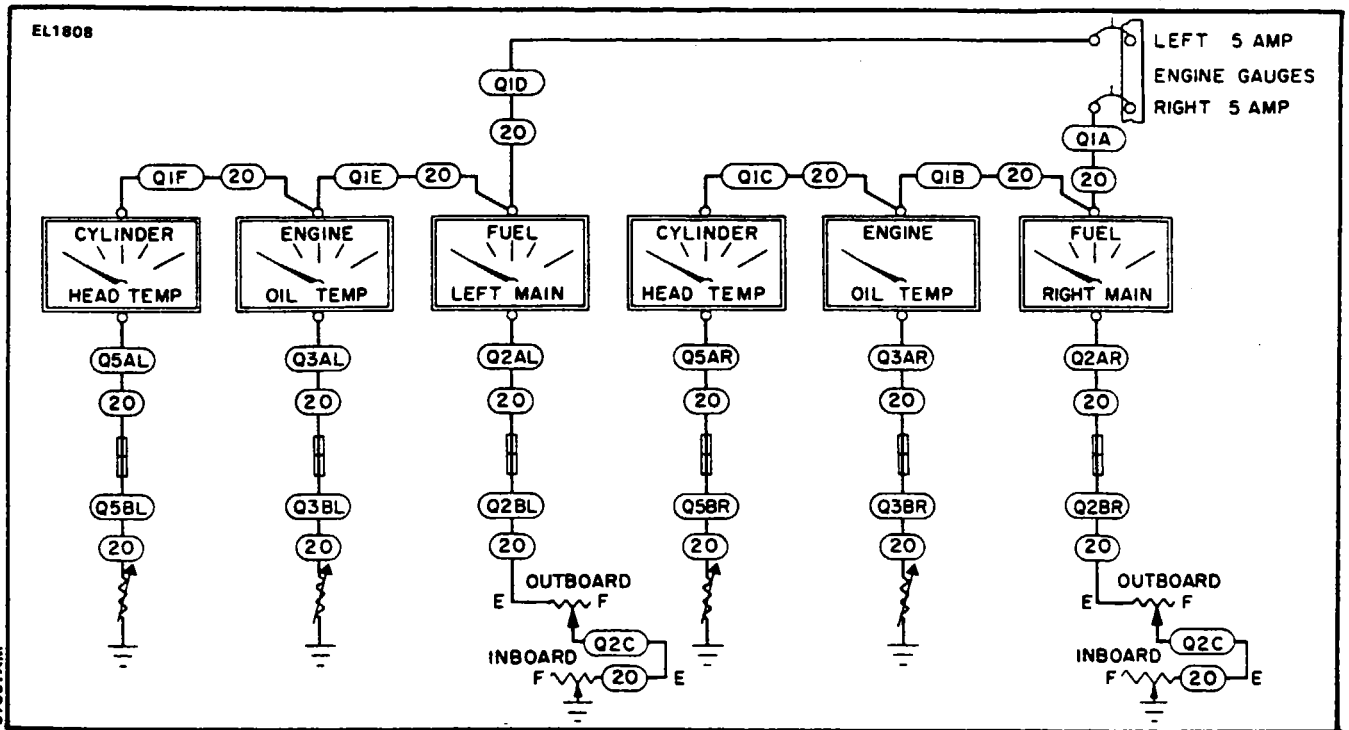

Figure 11-29. Engine Gauges (Early Models)

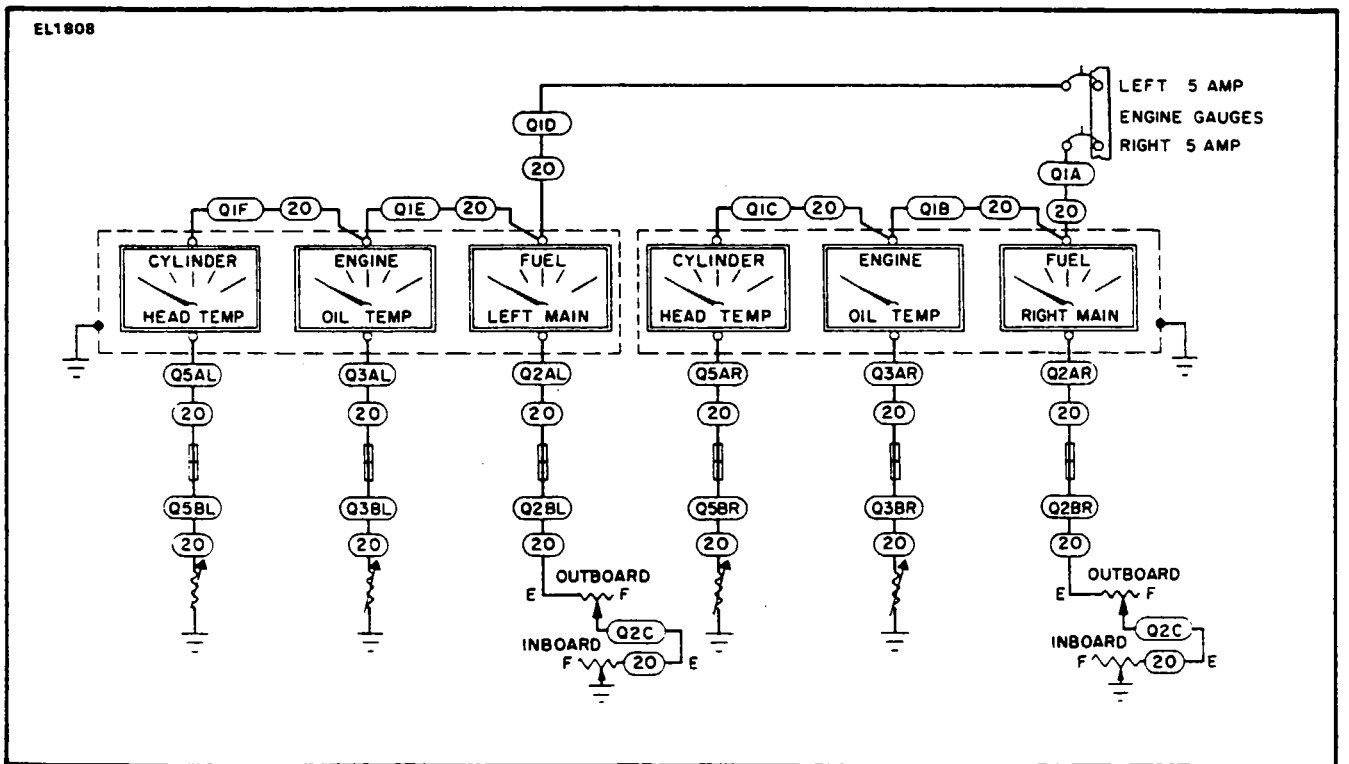

Figure 11-30. Engine Gauges (Later Models)

PIPER SENECA II SERVICE MANUAL

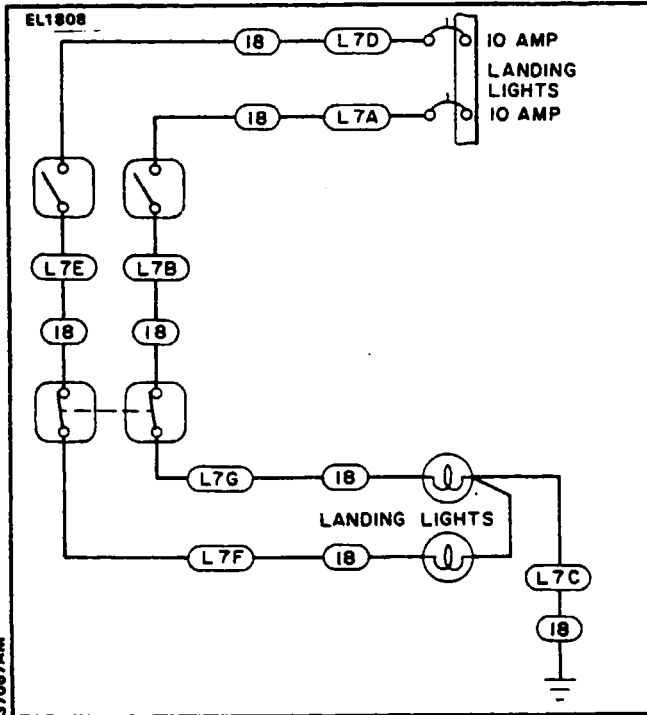

Figure 11-31. Landing Lights

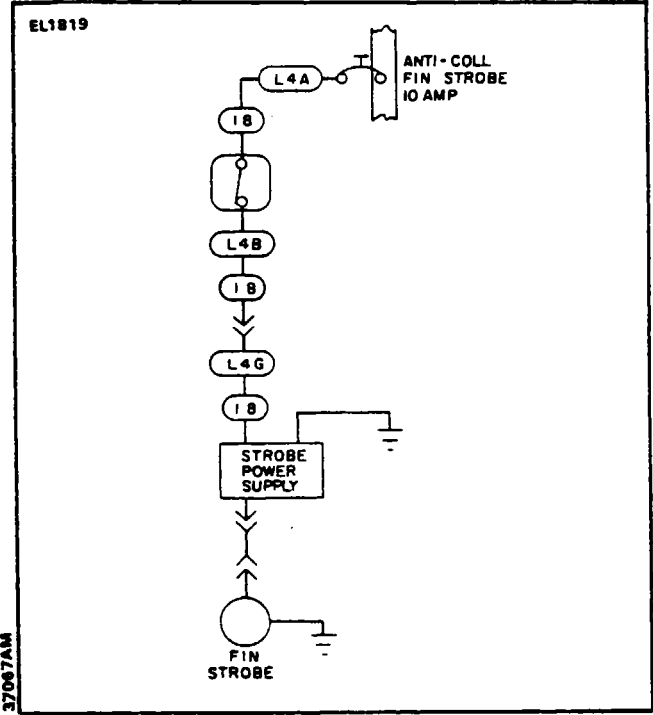

Figure 11-32. Anti-Collision Fin Strobe

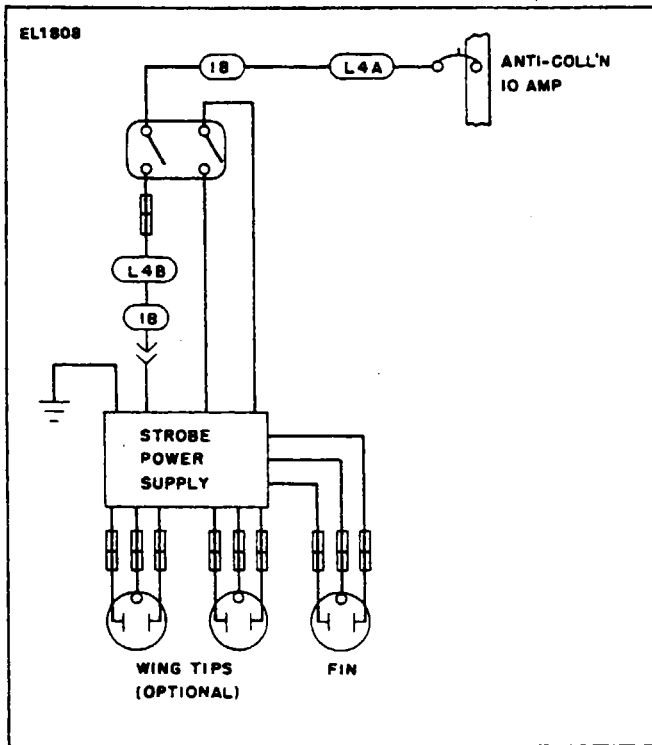

Figure 11-32a. Anti-Collision Strobes

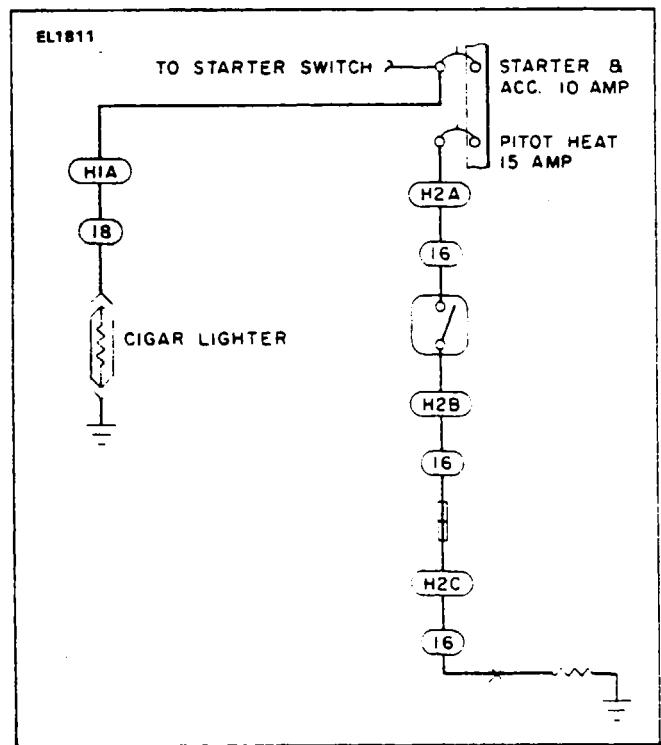

Figure 11-32b. Pitot Heat and Cigar Lighter

PIPER SENECA II SERVICE MANUAL

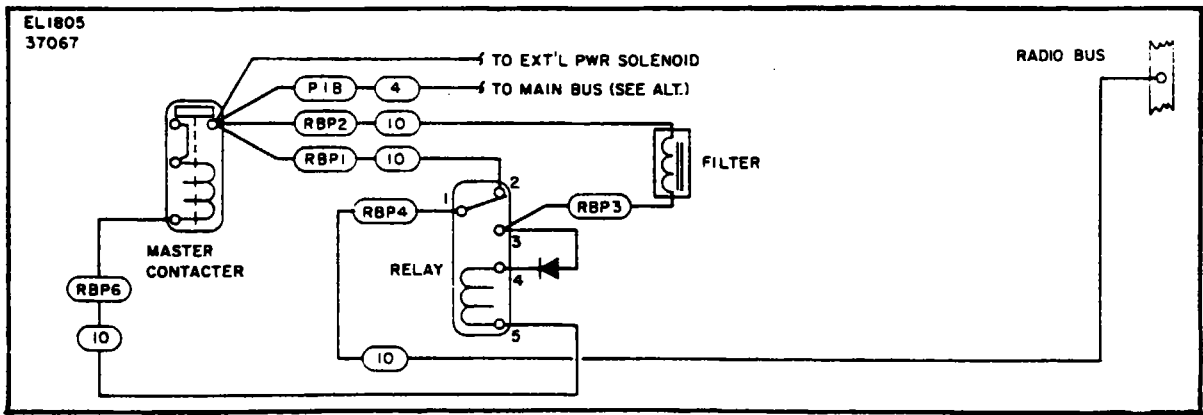

Figure 11-33. Radio Bus Power S/N 34-7570001 to 34-7570337

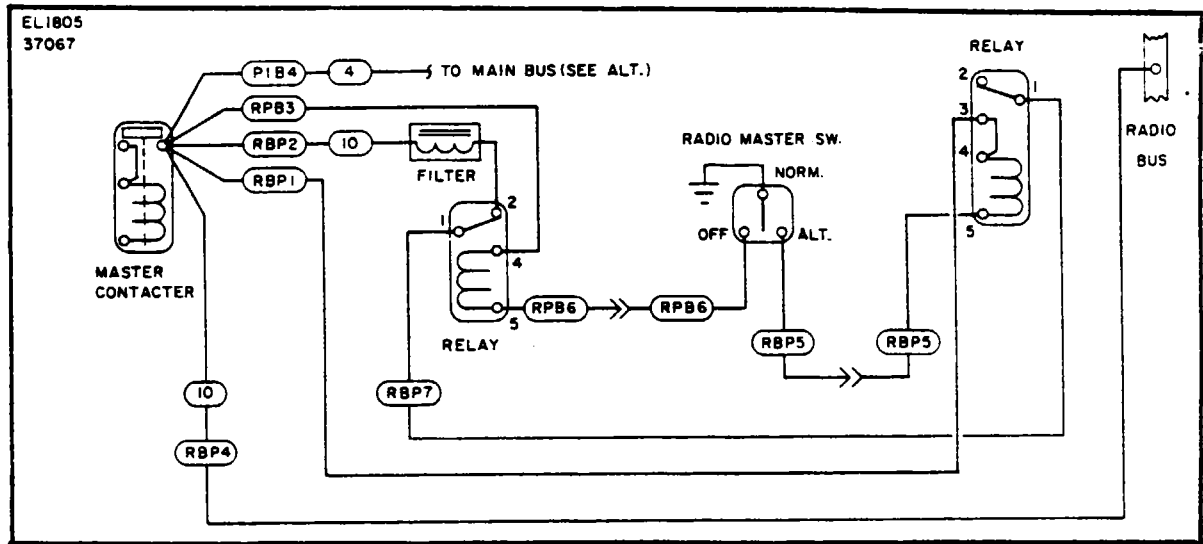

Figure 11-33a. Radio Bus Power S/N 34-7670001 to 34-8070001

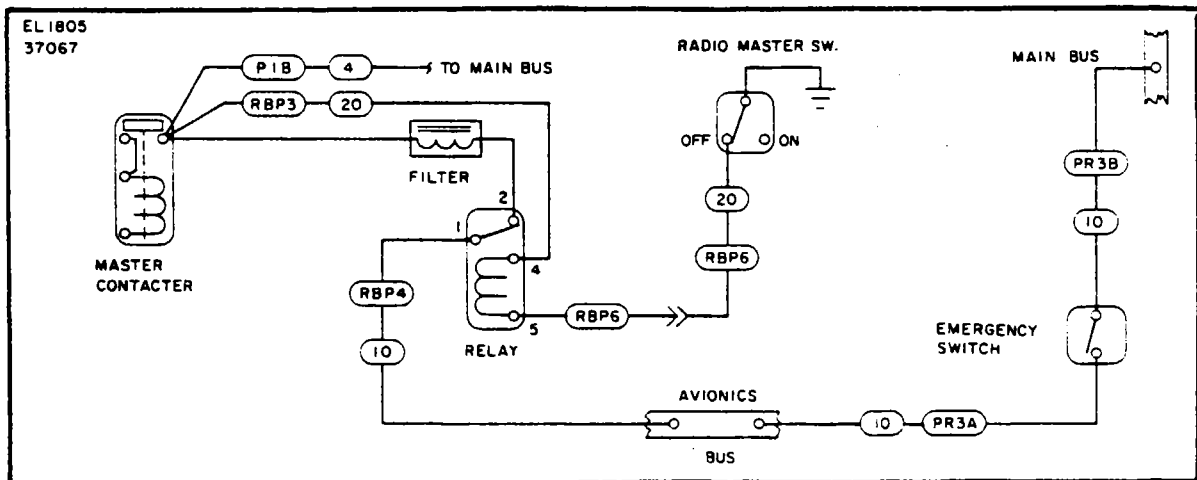

Figure 11-33b. Radio Bus Power S/N 34-8070002 and up

PIPER SENECA II SERVICE MANUAL

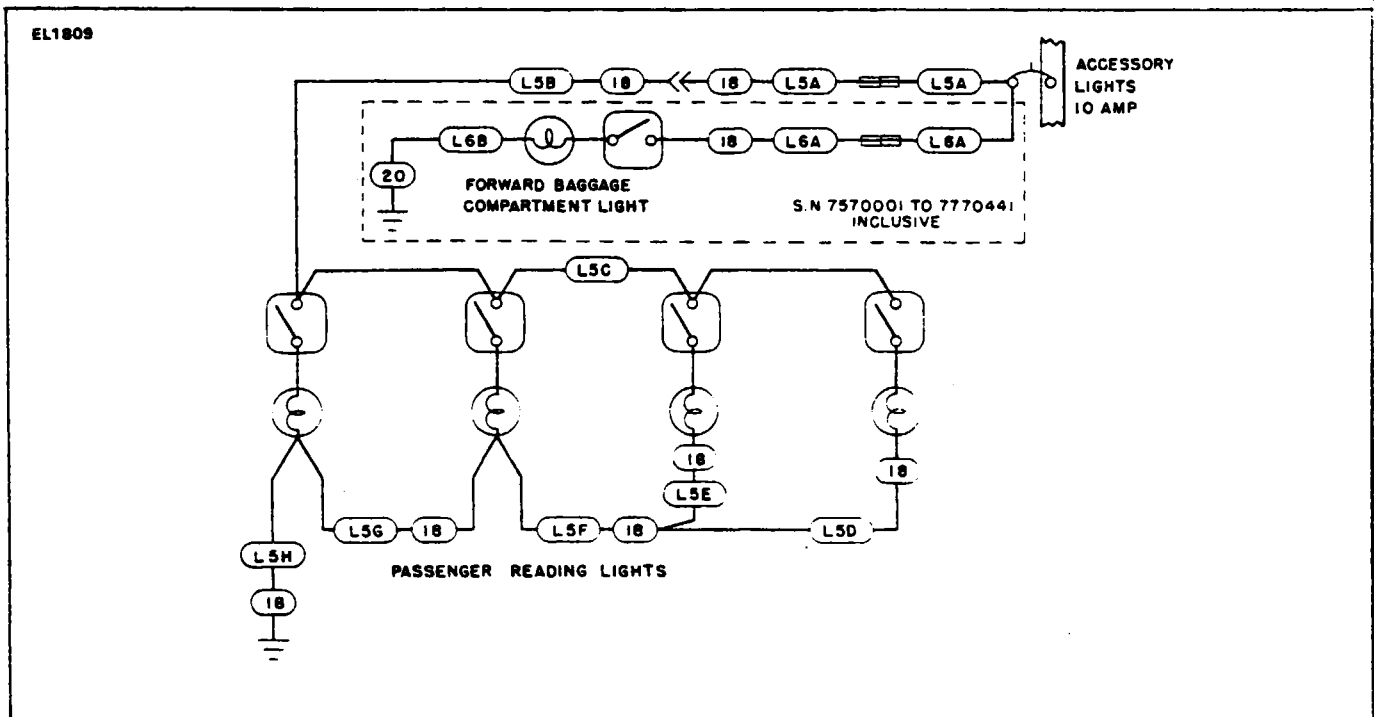

Figure 11-34. Reading and Baggage Lights S/N 34-757001 and up

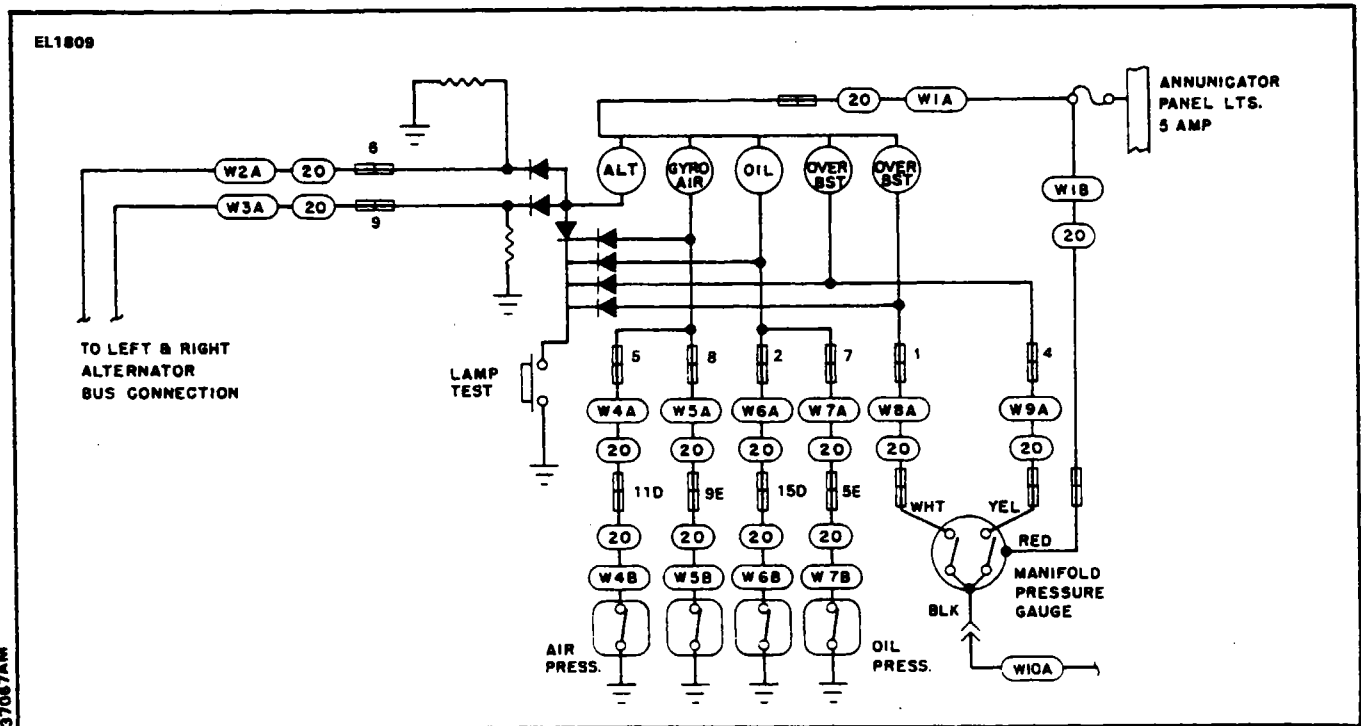

Figure 11-35. Annunciator Panel

THIS PAGE INTENTIONALLY LEFT BLANK

2110

ELECTRICAL SYSTEM

PIPER SENECA II SERVICE MANUAL

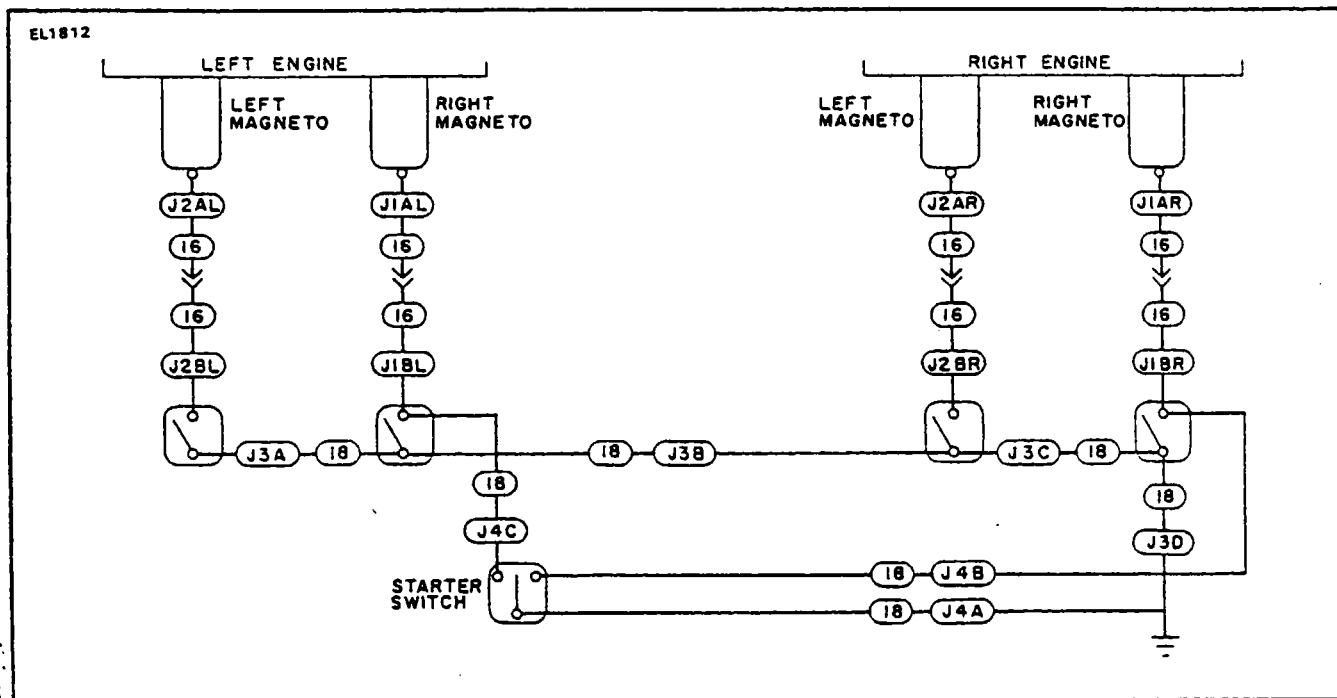

Figure 11-37. Magnetos

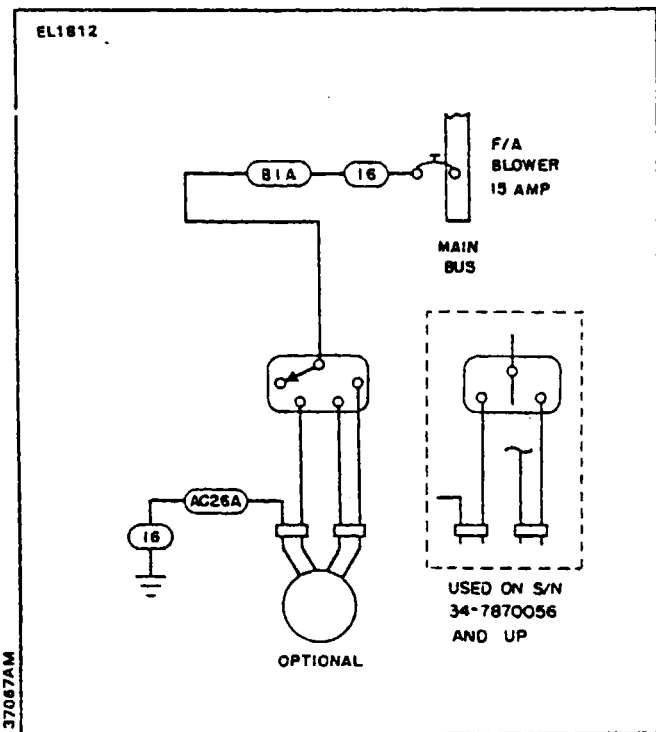

Figure 11-38. Ventilation Air Blower

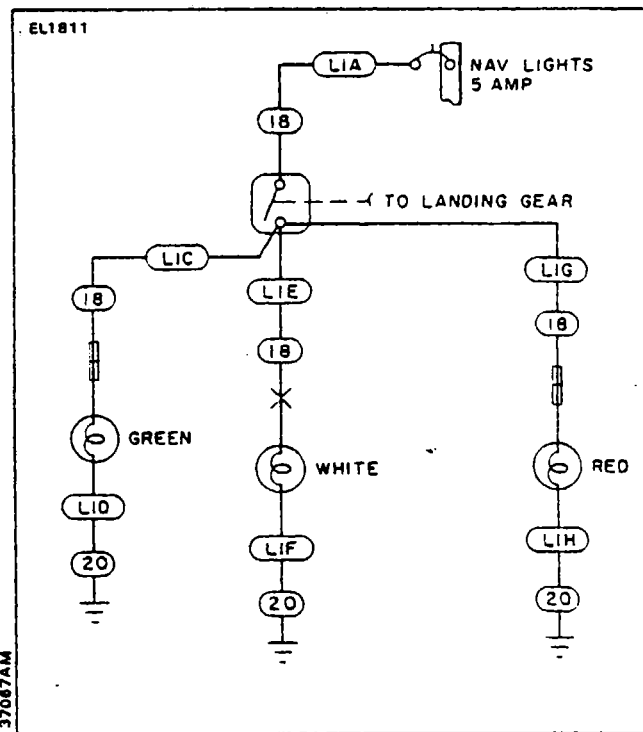

Figure 11-39. Position Lights

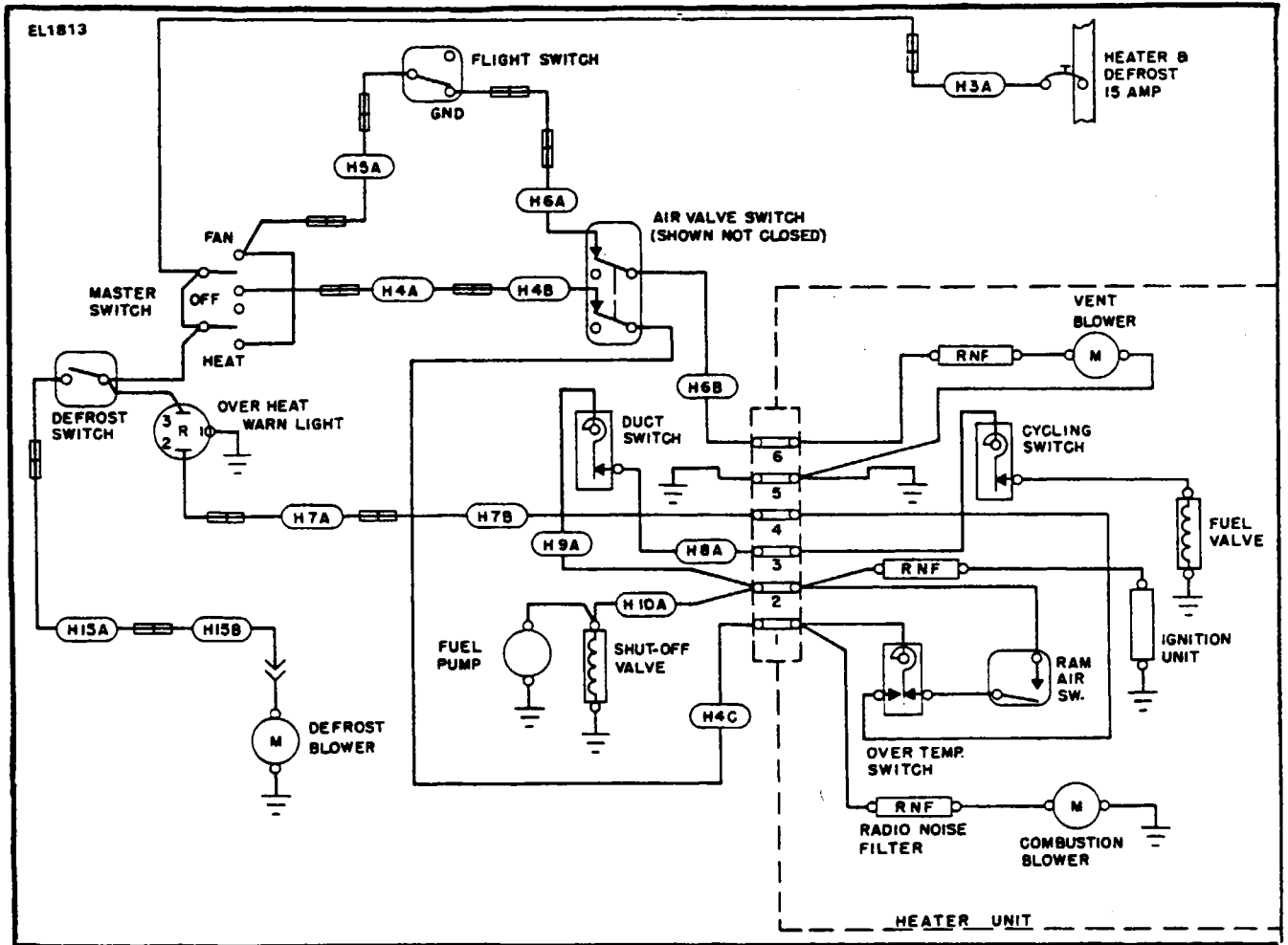

Figure 11-40. Heater and Defroster

INTENTIONALLY LEFT BLANK

PIPER SENECA II SERVICE MANUAL

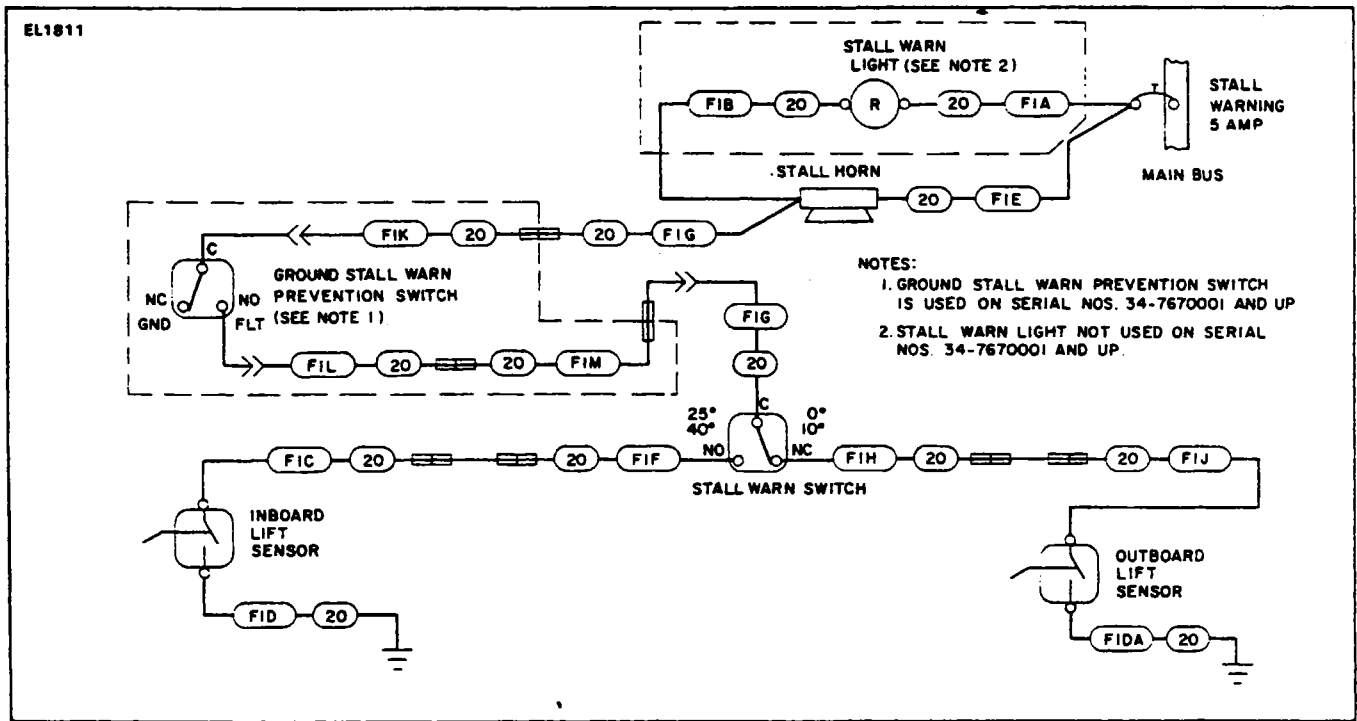

Figure 11-41. Stall Warning

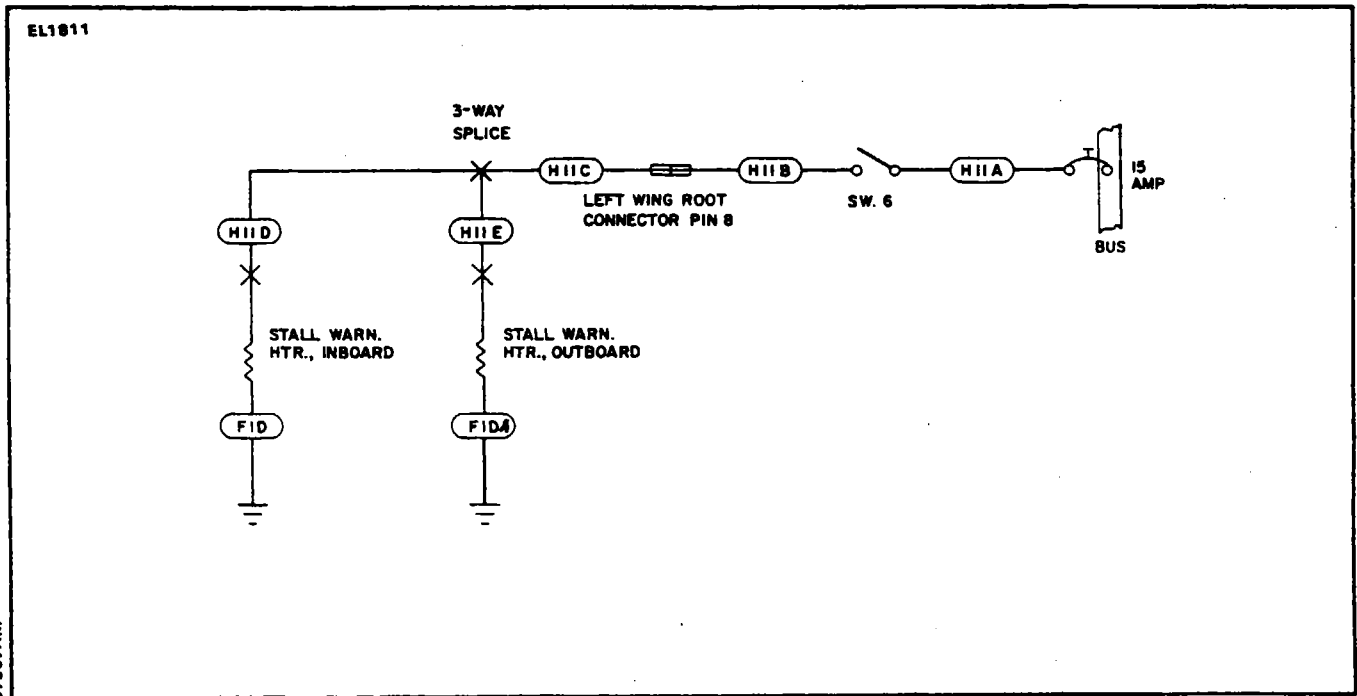

Figure 11-42. Stall Warning (Sensor Heaters)

PIPER SENECA II SERVICE MANUAL

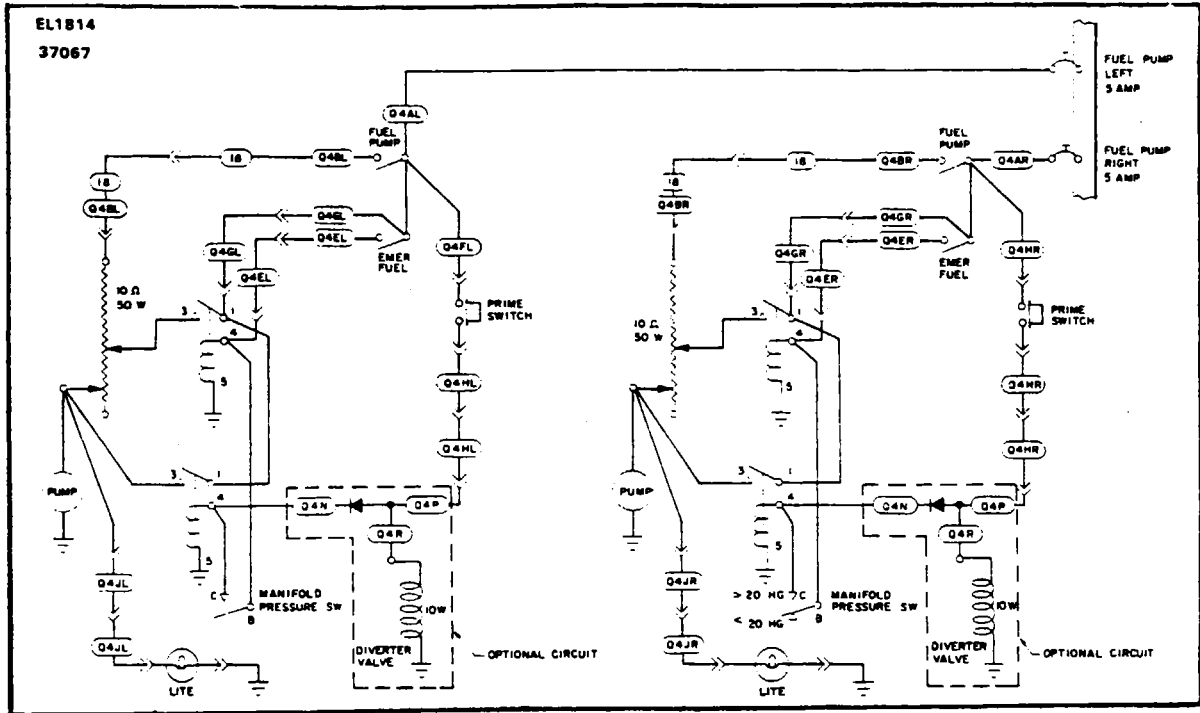

Figure 11-43. Fuel Pumps (Auxiliary System)

SERIAL NOS. 34-7670057 TO 34-7670097 AND
AIRCRAFT MODIFIED BY PIPER MOD. KIT 760 926V.

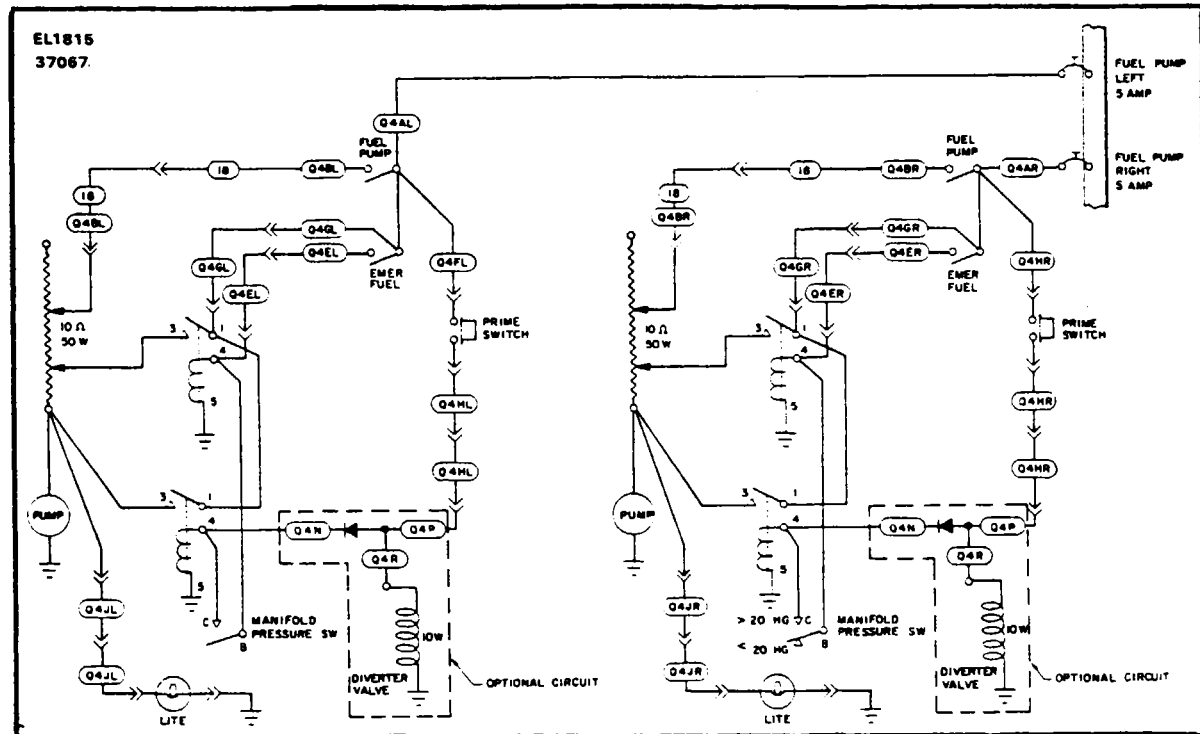

Figure 11-44. Fuel Pumps (Auxiliary System)

SERIAL NOS. 34-7670098 AND UP

Revised: 11/12/82

PIPER SENECA II SERVICE MANUAL

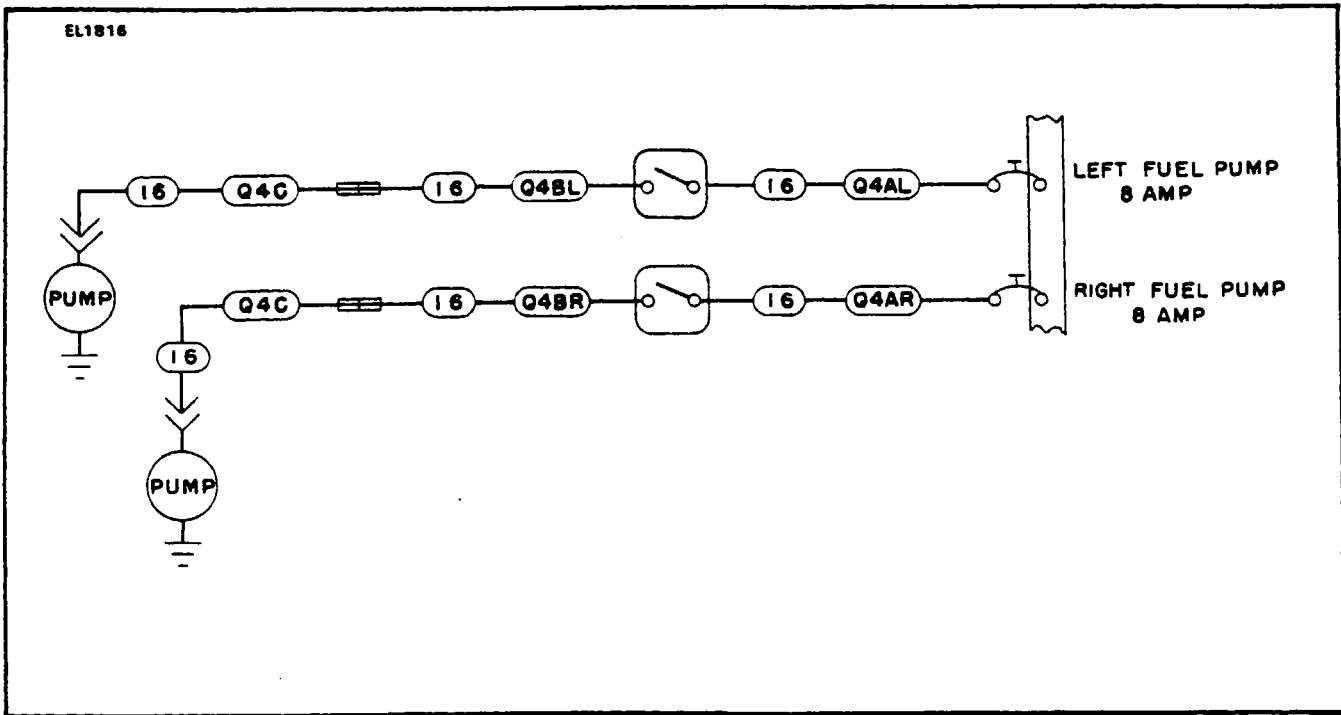

Figure 11-45. Left and Right Fuel Pump

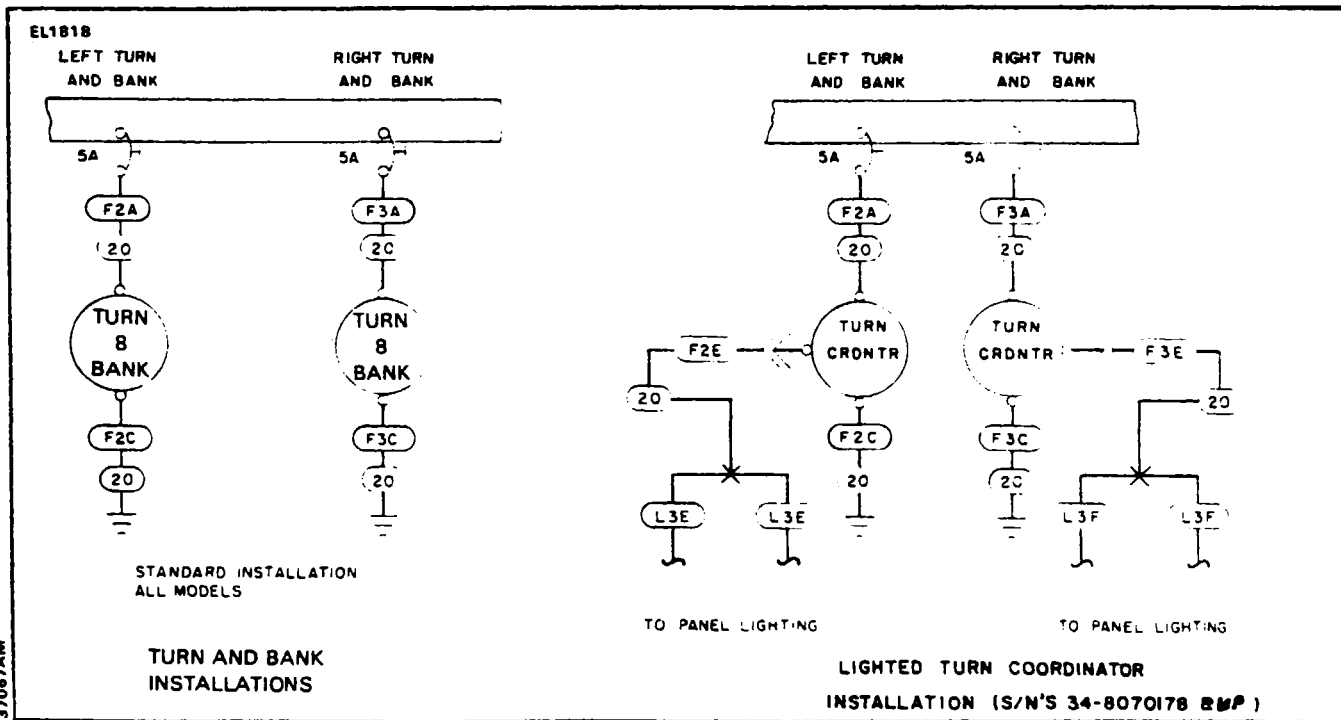

Figure 11-46. Turn and Bank Schematics

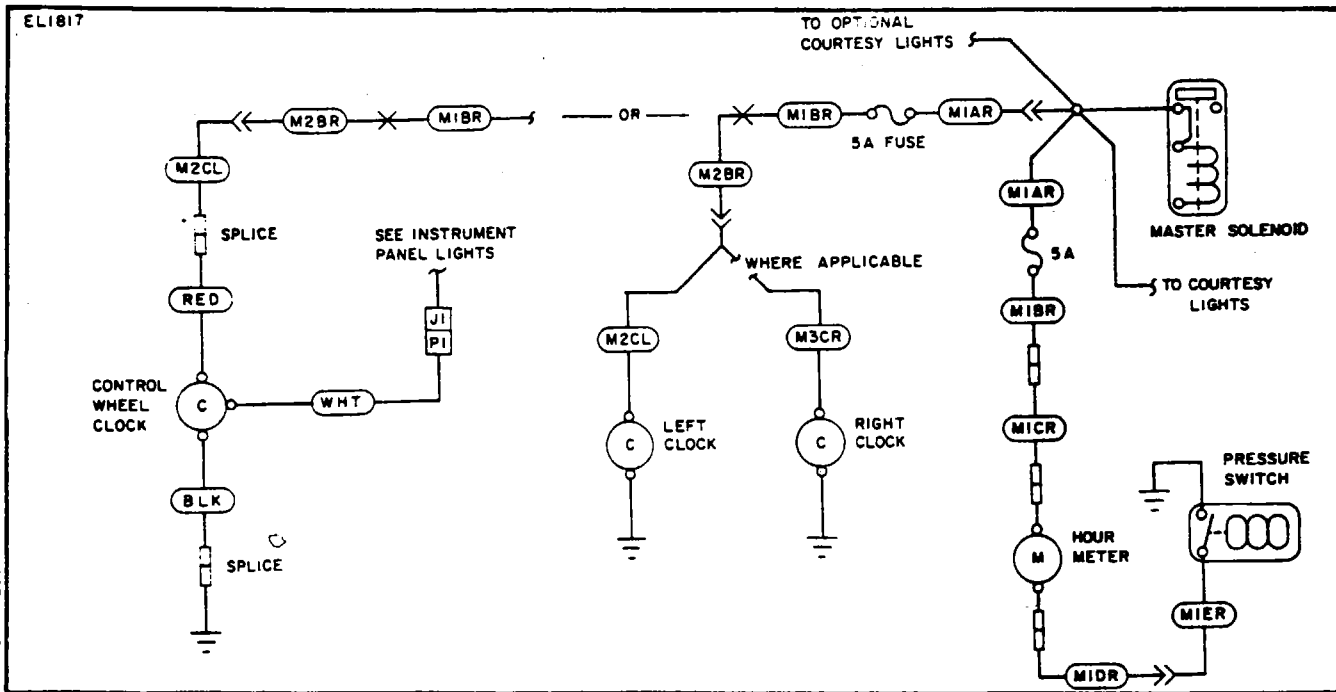

Figure 11-47. Electric Clock and Hourmeter (Optional)

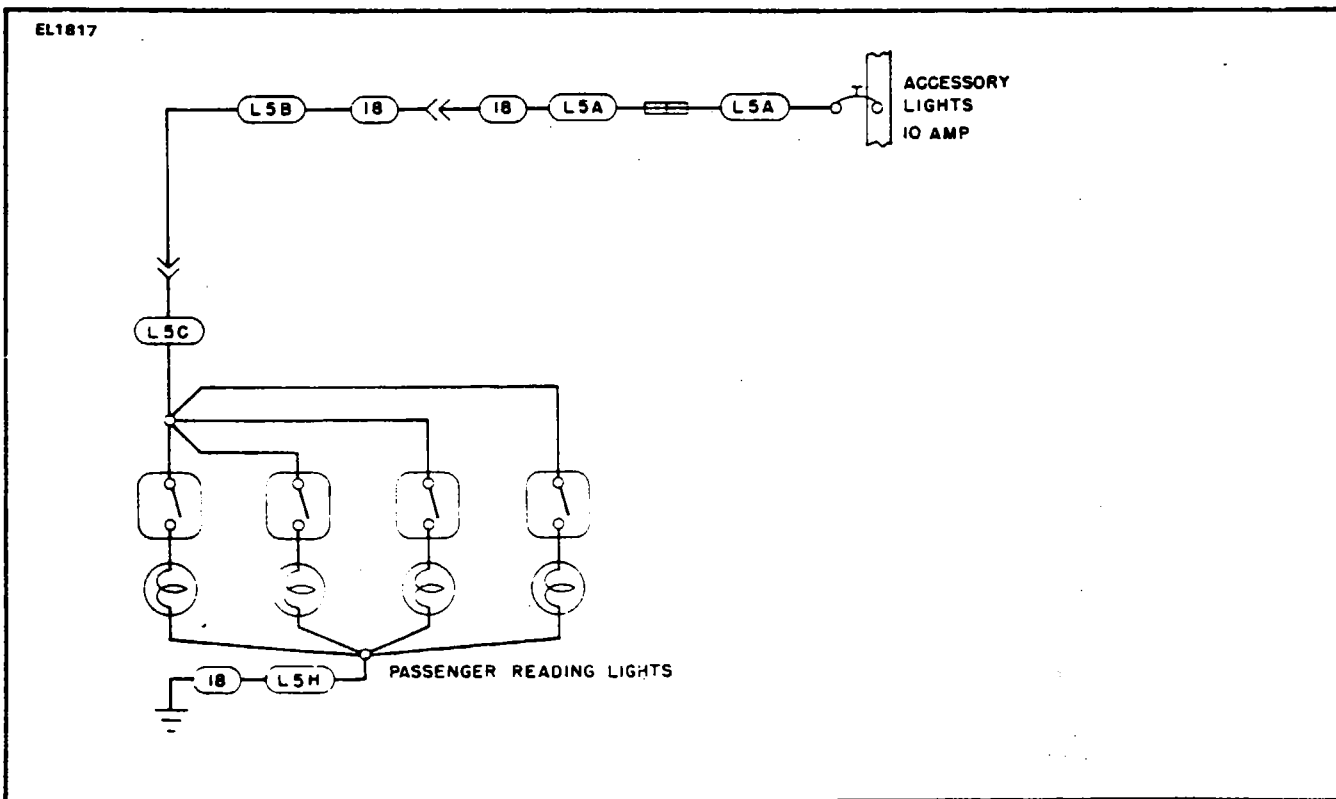

Figure 11-48. Reading Lights S/N 34-7570001 to 34-7770441

PIPER SENECA II SERVICE MANUAL

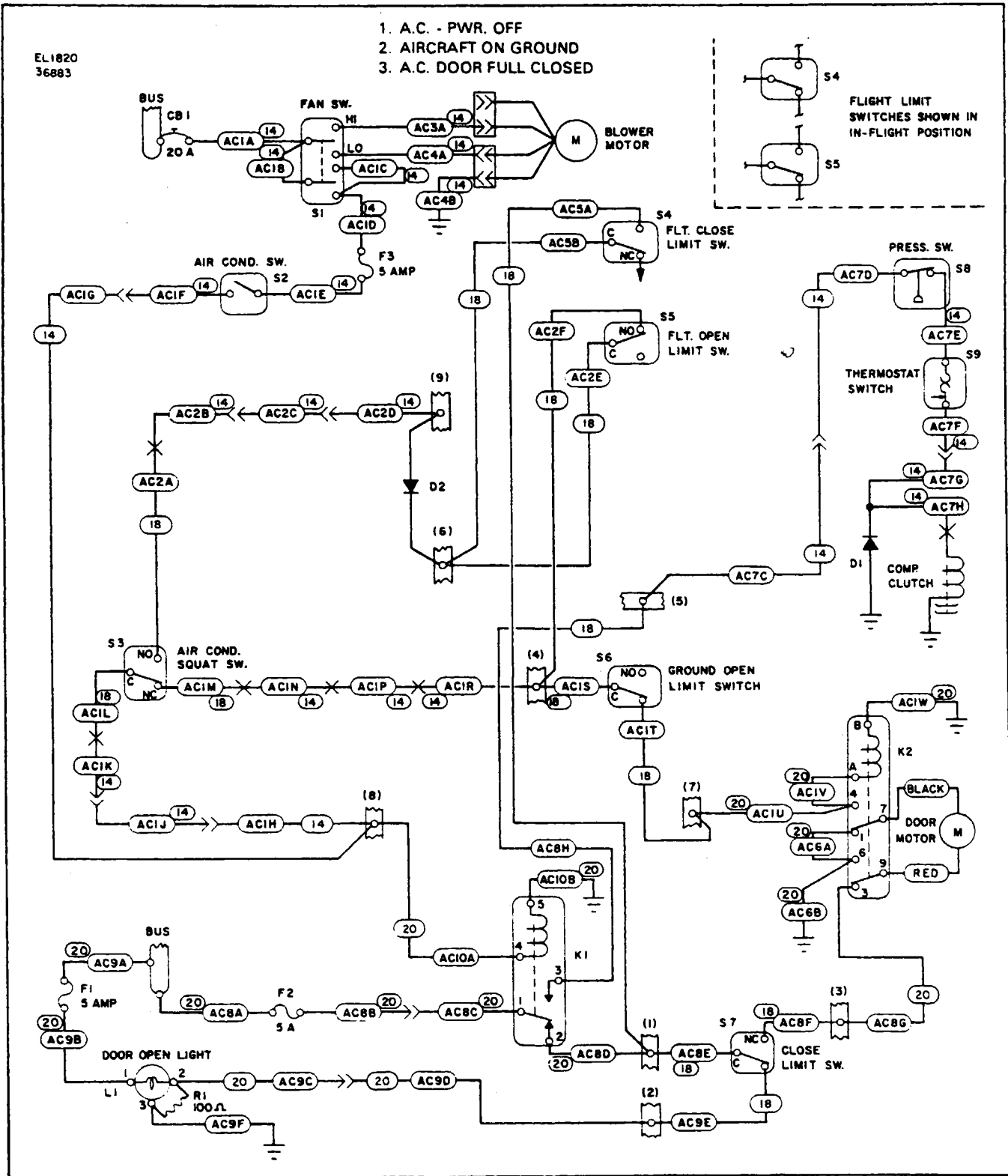
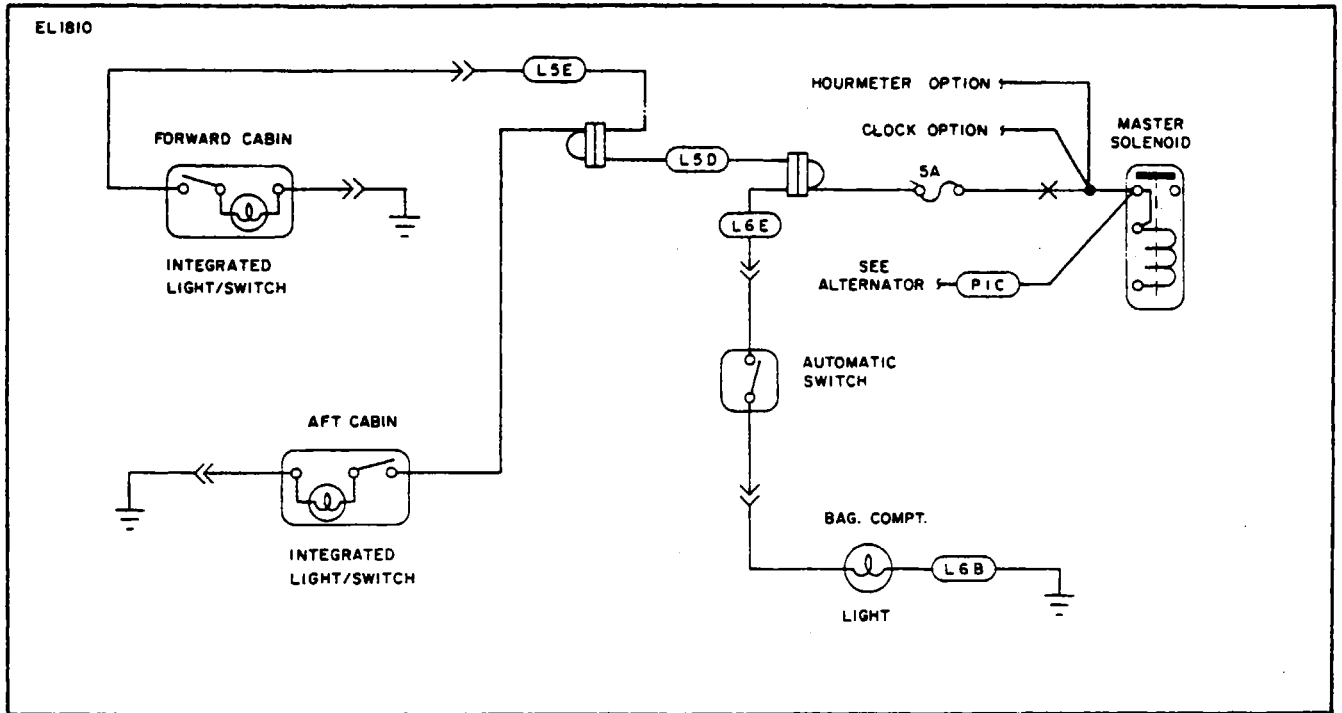

Figure 11-49. Air Conditioning

PIPER SENECA II SERVICE MANUAL



37067AM

Figure 11-50. Courtesy Lights (Optional)
(Serial Nos. 34-7970105 and up)

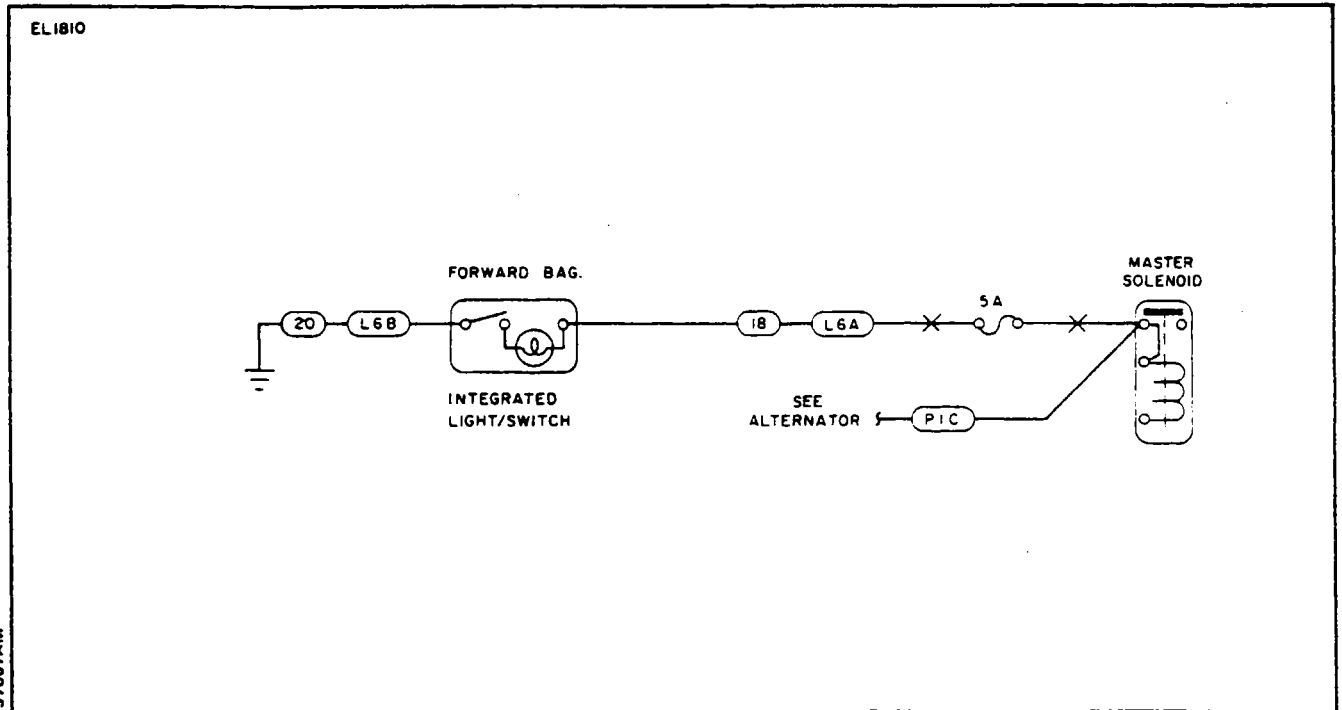

37067AM

Figure 11-51. Forward Baggage Compartment Lights (Optional)
(Serial Nos. 34-7970105 and up)

Revised: 11/12/82

PIPER SENECA II SERVICE MANUAL

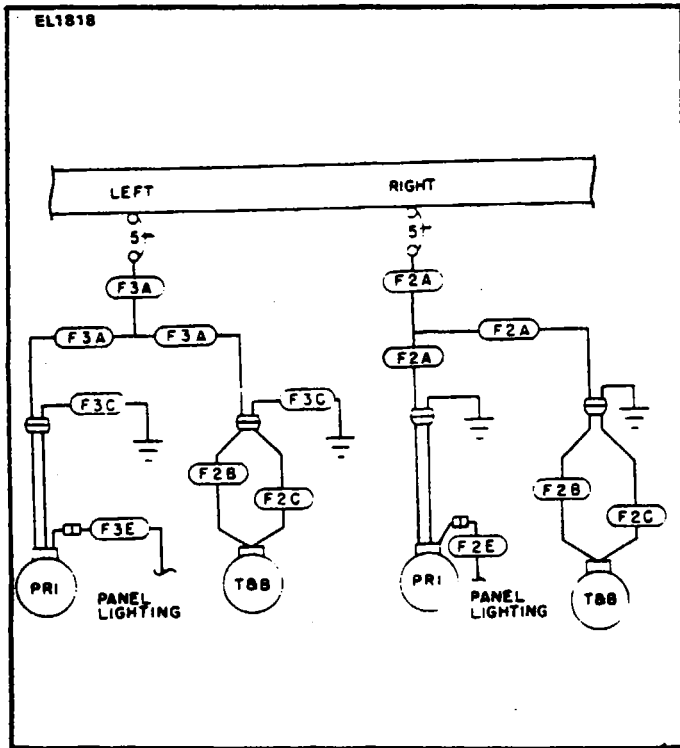

INTENTIONALLY LEFT BLANK

Figure 11-52. Alternate Turn and Bank

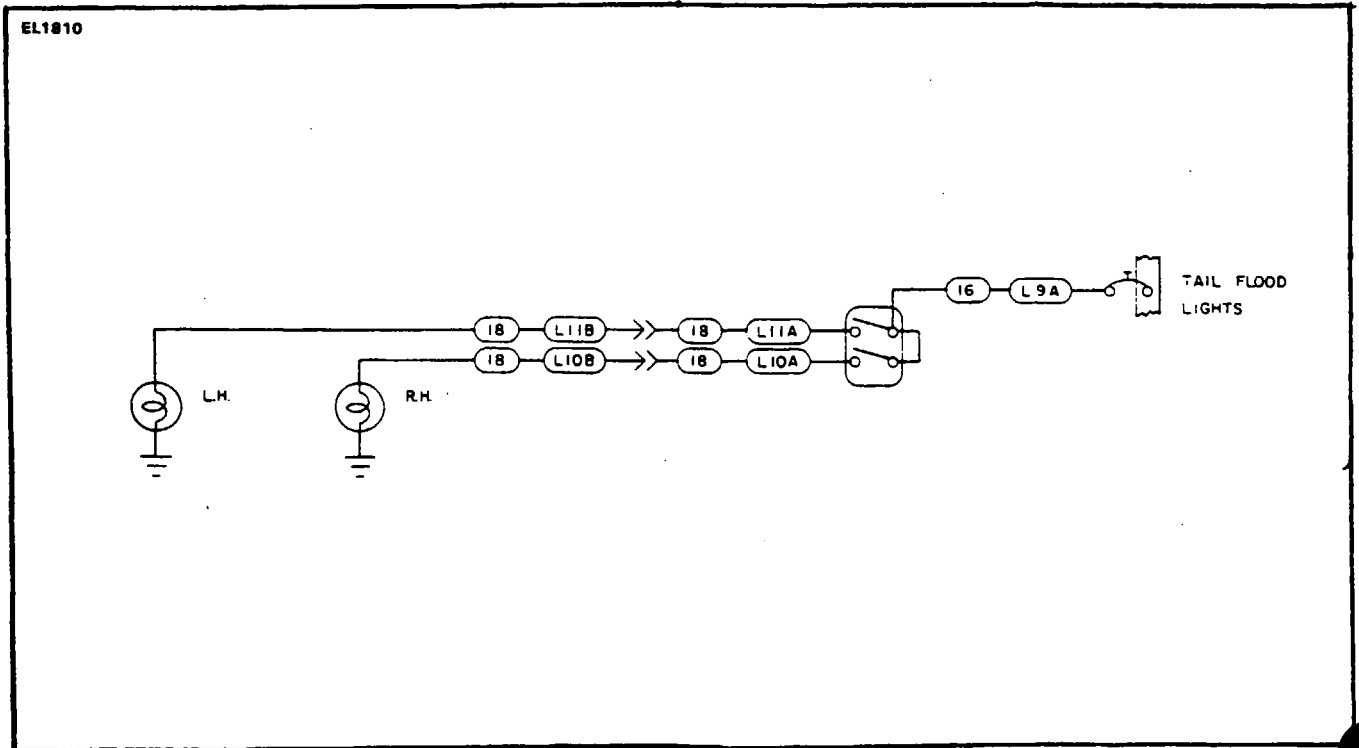

Figure 11-53. Tail Flood (Logo) (Optional)

SECTION XII ELECTRONICS

Paragraph		Aerofiche Grid No.
12-1.	Introduction	2I21
12-2.	Emergency Locator Transmitter	2I21
12-3.	Description	2I21
12-4.	Battery Removal and Installation. (Garrett Mfg. Ltd.) (2 Year Magnesium)	2I21
12-5.	Not used	
12-6.	Battery Removal and Installation (Communications Components Corp.)	2I23
12-7.	Battery Removal and Installation (Narco)	2I24
12-8.	Description, Operation and Testing of Pilot's Remote Switch	2J2
12-9.	Testing Emergency Locator Transmitter	2J2
12-10.	Avionics Master and Emergency Switch Circuit	2J4
12-11.	Description and Operation	2J4
12-12.	Autoflight	2J4
12-13.	General	2J4
12-14.	Non-Piper A.F.C.S. Equipment Contacts	2J4
12-15.	Piper A.F.C.S. Equipment	2J5

Revised: 11/12/82

2I20

SECTION XII

ELECTRONICS

12-1. INTRODUCTION. This section of the manual contains information necessary to perform operational checks of the Emergency Locator Transmitter (ELT), with and without a pilot's remote switch. Included are the appropriate removal and installation instructions to facilitate battery replacement.

12-2. EMERGENCY LOCATOR TRANSMITTER

12-3. DESCRIPTION. The electrical power for the ELT is totally supplied by its own self-contained battery. The battery should be replaced on the date marked on the battery. If the transmitter has been used in an emergency situation during this 2 or 5 year period or it has more than one hour of accumulated test time, the battery must be replaced according to FAA regulations. To replace battery pack in the transmitter, it is necessary to remove the transmitter from the aircraft.

12-4. BATTERY REMOVAL AND INSTALLTION (GARRETT MFG. LTD.). (2 year, magnesium battery, refer to Figure 12-1.) The ELT is located on mounting brackets on the right side of the fuselage aft of sta. 259.31.

- a. Remove the access plate on the right side of the fuselage aft of sta. 259.31.
- b. Set the ON/ARM/OFF switch on the transmitter to the OFF position.
- c. Disconnect the antenna coax from the transmitter.
- d. Disconnect the harness to the pilot's remote switch.
- e. Remove the rear mounting bracket by pulling the plastic knob out. Remove the transmitter from the airplane.
- f. Remove the two long or four short screws securing the transmitter plain end cap. Remove the plain end cap.
- g. Disconnect the battery connector from the board terminals.
- h. Withdraw the battery pack from the transmitter case.
- i. Before installing the new battery pack, check the replacement date printed on the battery. Transfer this date onto the outside of the ELT.
- j. Slide the new battery pack, plain end first, into transmitter. It may be necessary to rotate the battery slightly to get it seated properly in the transmitter case and to achieve correct orientation of the battery connector.
- k. Connect the battery connector to board terminals.
- l. Insure O-ring is fitted in plain end cap and correctly seated.
- m. Refit end cap and secure with the screws previously removed.

NOTE

Do not overtighten the end cap screws.

- n. Place transmitter into its mounting bracket; replace rear mounting bracket by pushing plastic knob into place.
- o. Connect the pilot's remote switch harness to the transmitter.
- p. Connect the antenna coax to the transmitter.

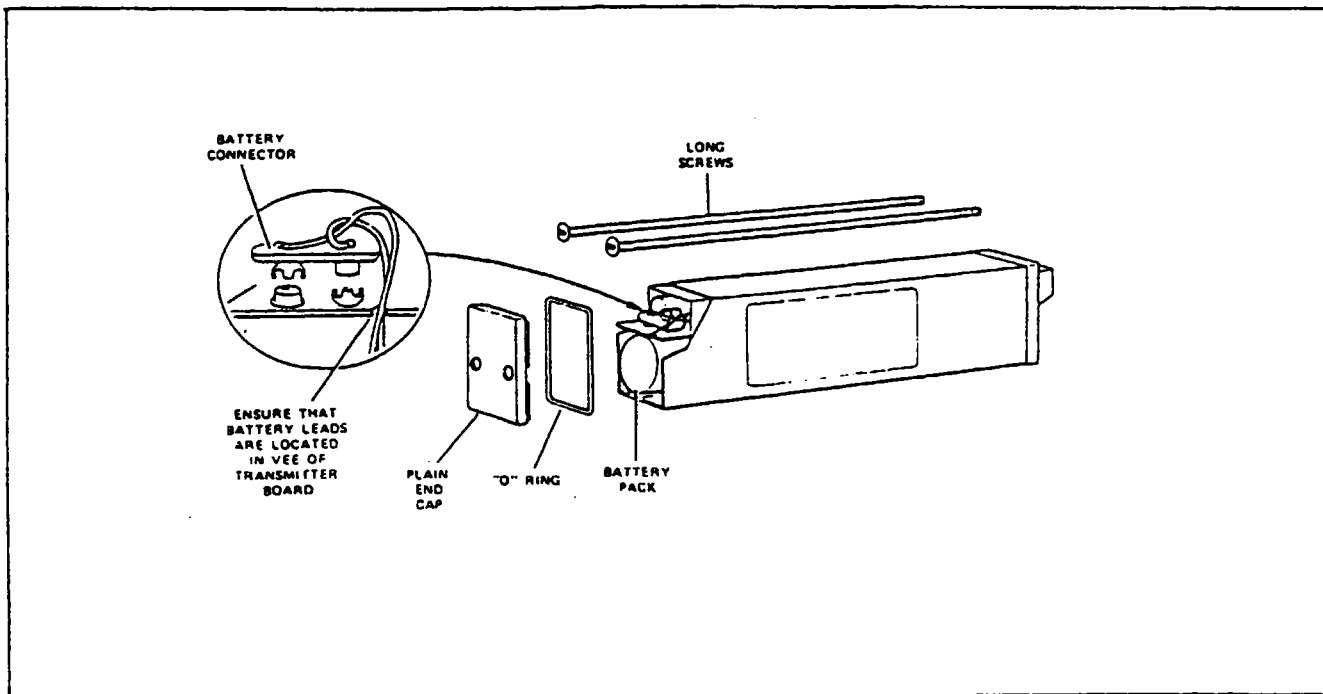

Figure 12-1. Two Year, Magnesium Battery Connections

NOTE

Before installing access plate ascertain that transmitter switch is in the ARM position. It may also be advisable to test the unit operation before installing the access panel. (Refer to Paragraph 12-9.)

- q. Install the access plate on the right side of the fuselage aft of sta. 259.31. Make an entry in the aircraft logbook, including the new battery run out date.

12-5. NOT USED

PIPER SENECA II SERVICE MANUAL

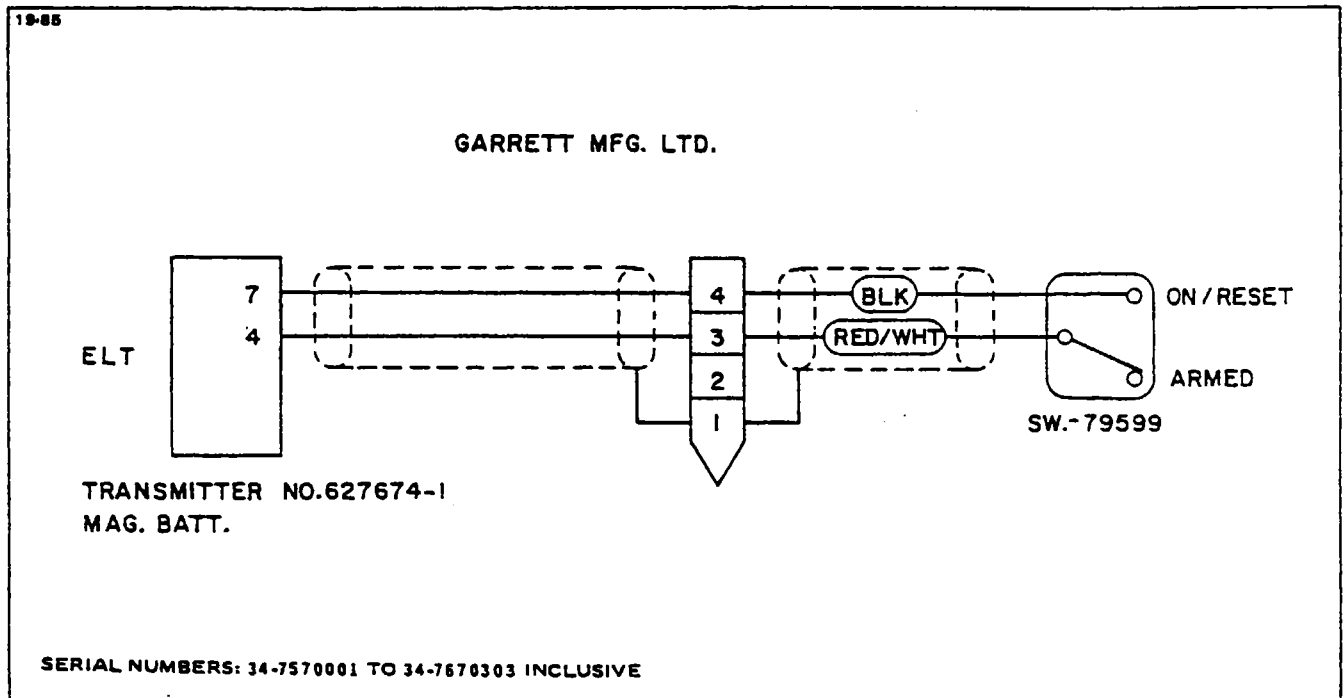

Figure 12-2. Garrett ELT Schematic

12-6. BATTERY REMOVAL AND INSTALLATION (COMMUNICATIONS COMPONENTS CORP.).

The ELT is located on the right side of the airplane tail section, ahead of the stabilator.

- Remove the access plate on the right side of fuselage aft of sta. 259.31.
- Rotate the ON/ARM/OFF switch to the OFF position.
- Disconnect the antenna coax cable (twist left, then pull outward).
- Disconnect the harness to the pilot's remote switch.

THIS SPACE INTENTIONALLY LEFT BLANK

- e. Remove the forward mounting bracket by pulling the black plastic knob out. Remove the transmitter from the airplane.
- f. Remove the six Phillips-head screws securing the transmitter cover. Remove the cover.
- g. Lift out the old battery pack.
- h. Copy the expiration date on the battery into the space provided on the external ELT name and date plate.
- i. Disconnect and replace with a new battery pack. The nylon battery connector is a friction fit and is easily removed by pulling on the exposed end.
- j. Insert transmitter into airplane and fit into place. Replace mounting bracket by pushing the black plastic knob into place.
- k. Reconnect the pilot's remote switch harness and the antenna coax cable to the transmitter.
- l. Set the ON/ARM/OFF switch to the ARM position.
- m. Reinstall the access plate previously removed.
- n. Make an entry in the aircraft logbook, including new battery runout date.

NOTE

It may be advisable to test the unit operation before installing the access plate. (See Testing Emergency Locator Transmitter.)

Inspect the external whip antenna for any damage. Avoid bending the whip. Any sharply bent or kinked whip should be replaced. Antenna damage may cause structural failure of whip in flight.

12-7. BATTERY REMOVAL AND INSTALLATION (NARCO). (Refer to Figures 12-3 and 12-4.)

- a. Set the ON/OFF/ARM switch on the transmitter to OFF.
- b. Disconnect antenna coaxial cable from E.L.T.
- c. Remove ELT from its mounting bracket by releasing the latch on the strap and sliding the ELT off the bracket.
- d. Extend the portable antenna.
- e. Unscrew the four screws that hold the control head to the battery casing and slide apart.
- f. Disconnect the battery by unsnapping the snap-off battery pigtail terminals from the bottom of the transmitter printed circuit board.
- g. Discard old battery pack. (DO NOT EXPOSE TO FLAME.)

CAUTION

The battery pack is shipped with a sealant on the inside lip so that a water tight seal will be retained. DO NOT REMOVE THIS SEALANT.

- h. Connect new battery pack terminals to the bottom of the circuit board.
- i. Reinsert the control head section into the battery pack being careful not to pinch any wires, and replace the four screws. If the four holes do not line up, rotate the battery pack 180° and reinsert.
- j. Slide the portable antenna back into the stowed position.
- k. Place transmitter into its mounting bracket and fasten the strap latch.
- l. Connect the antenna coaxial cable to the ELT and ensure that the contact separator is inserted between the antenna contact finger and the portable antenna. (Refer to Figure 12-4.)

PIPER SENECA II SERVICE MANUAL

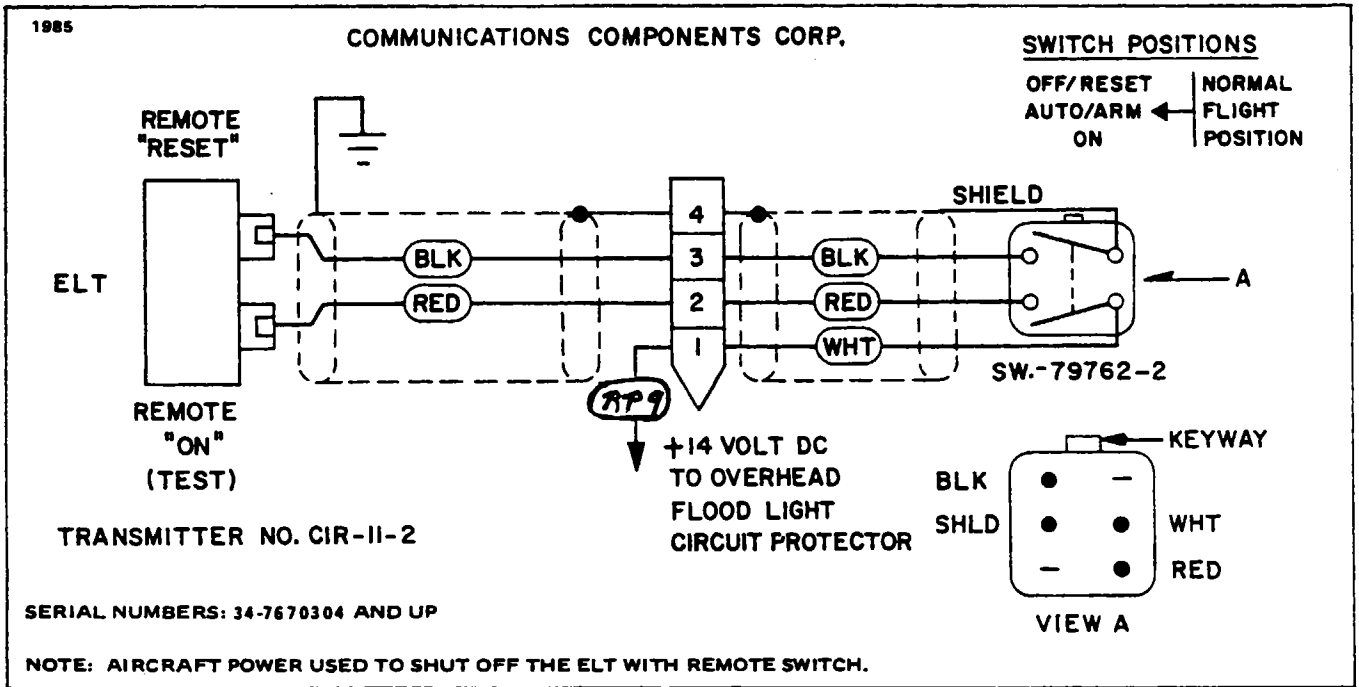

Figure 12-3. Communications Components ELT Schematic

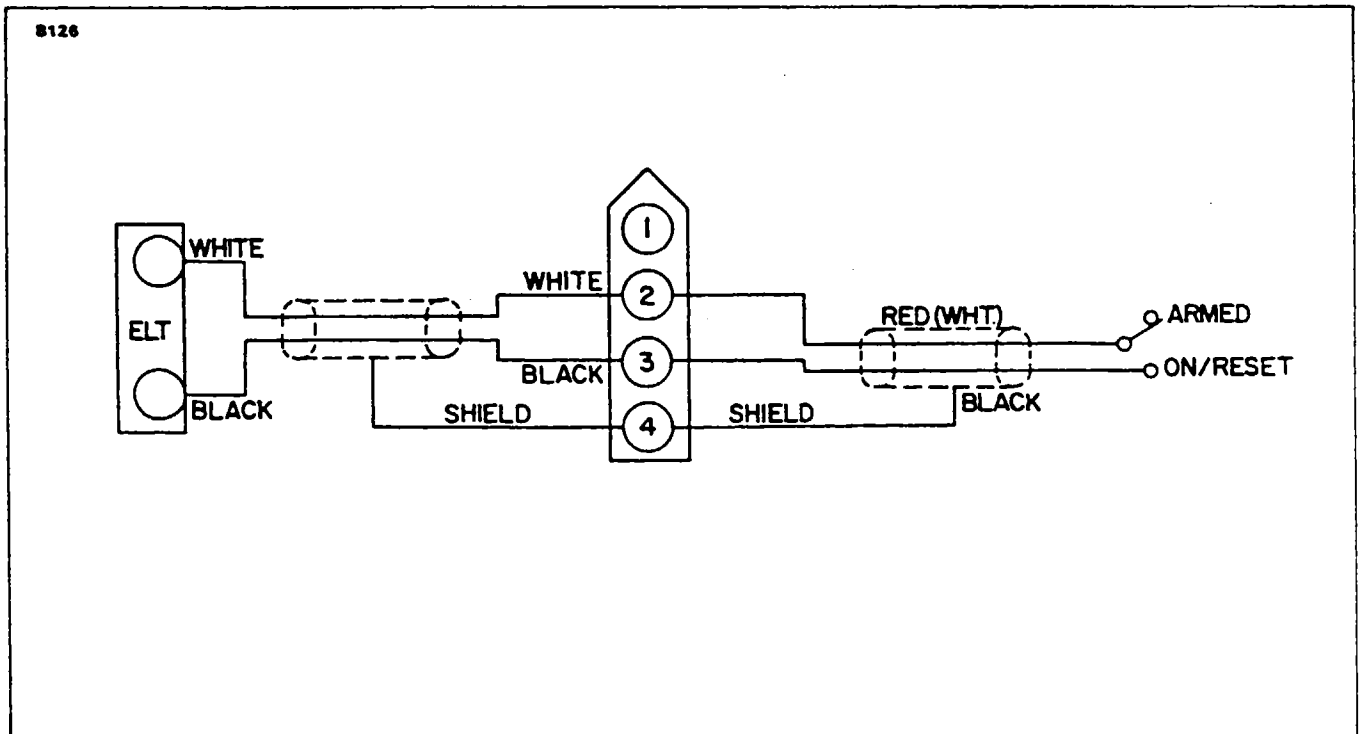

Figure 12-4. Emergency Locator Transmitter Schematic (Narco)

- m. Press RESET button and set ON/OFF/ARM switch to ARM.
- n. Make an entry in the aircraft logbook, including the new battery expiration date.
- o. A unit operational check may now be performed on the ELT. (Refer to Testing Emergency Locator Transmitter.)

NOTE

Inspect the external whip antenna for any damage. Avoid bending the whip. Any sharply bent or kinked whip should be replaced. Antenna damage may cause structural failure of whip in flight.

12-8. DESCRIPTION, OPERATION AND TESTING OF PILOT'S REMOTE SWITCH. (Refer to Pilot's Operating Handbook.)

12-9. TESTING EMERGENCY LOCATOR TRANSMITTER. The transmitter operates on the emergency frequencies of 121.5 and 243 MHz; both of these frequencies are monitored by the various FAA installations. Before performing any operational test of the ELT, the following precautions should be observed:

CAUTION

Testing of an ELT should be conducted in a screen room or metal enclosure to ensure that electromagnetic energy is not radiated during testing. If a shielded enclosure is not available, testing may be performed in accordance with the following procedures:

1. Test should be no longer than three audio sweeps.
2. If the antenna is removed, a dummy load should be substituted during the test.
3. Test should be conducted only within the time period made up of the first five minutes after any hour.
4. If the operational tests must be made at a time not included within the first five minutes after the hour, the test should be coordinated with the closest FAA Tower or Flight Service Station.

Consult FAA Advisory Circular AC 20-81 for detailed information concerning above cautions.

- a. Remove the access plate on the right side of the fuselage aft of sta. 259.31.
- b. Tune the aircraft communications receiver to 121.5 MHz and switch the receiver ON; deactivate the squelch, and turn the receiver volume up until a slight background noise is heard.

NOTE

If the aircraft is not fitted with a communications receiver, request that the tower listen for your test.

- c. On the transmitter, set the ON ARM OFF switch to the ON position. Keep the switch in this position for only a few seconds; then set to the OFF position. Return to the ARM position.

PIPER SENECA II SERVICE MANUAL

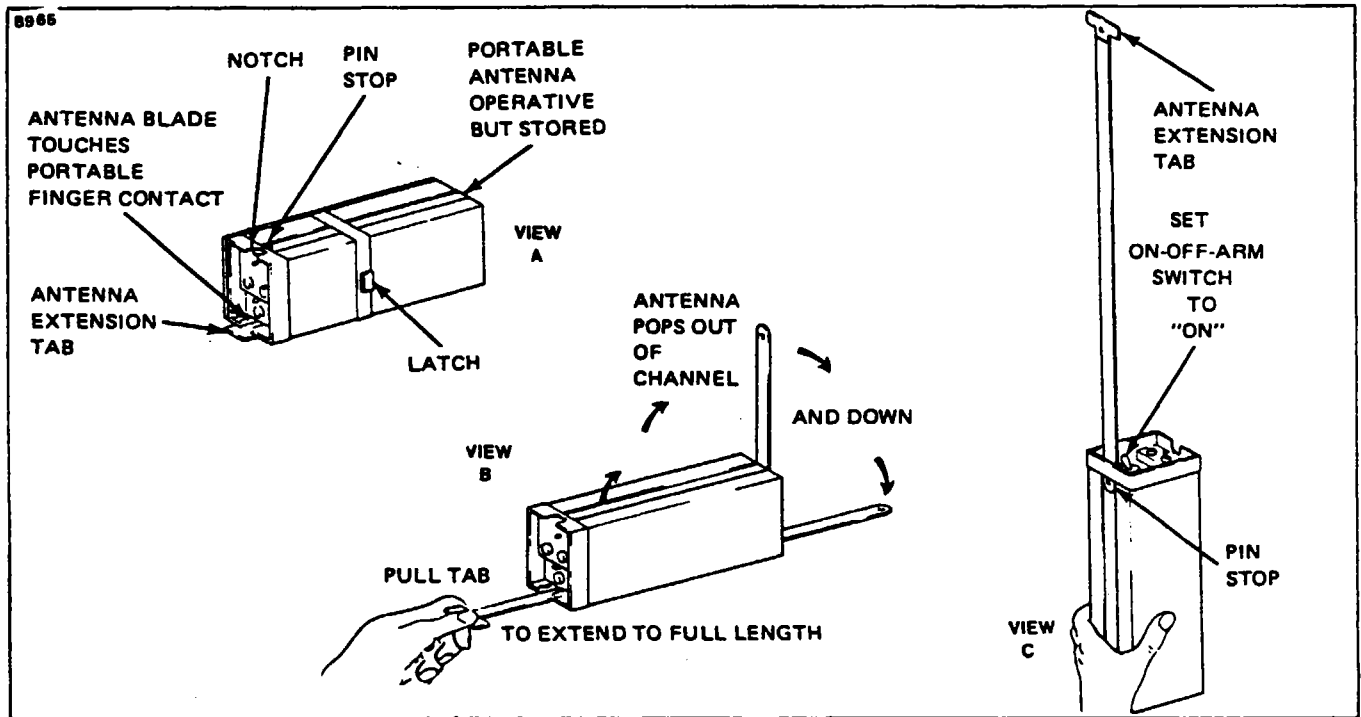

Figure 12-5. ELT Portable Folding Antenna (Narco)

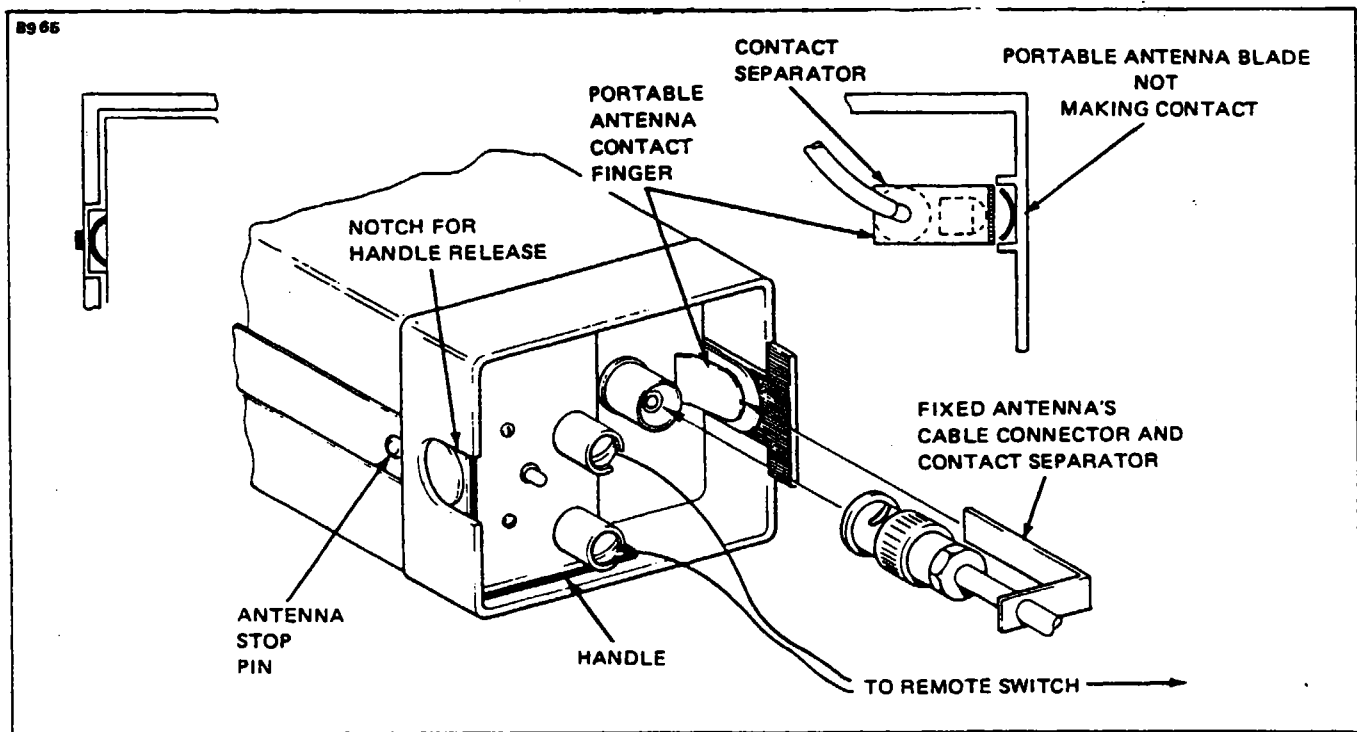

Figure 12-6. ELT Using Fixed Aircraft Antenna (Narco)

PIPER SENECA II SERVICE MANUAL

NOTE

The test transmission should have been picked up by the aircraft communications receiver and or control tower. During cold weather, there may be a slight delay before transmission occurs.

- d. A transmitter which is functioning properly should emit a characteristic downward swept tone.
- e. When test is completed, ascertain the transmitter ON/ARM/OFF switch is in the ARM position.
- f. Place the access panel on the right side of the fuselage aft of sta. 259.31.

WARNING

Whenever the unit is checked by moving the transmitter ON ARM OFF switch from the ARM to the ON position, it must then be moved to the OFF position before reverting to the ARM position again.

CAUTION

Under normal conditions, the transmitter switch must be set to arm.

12-10. AVIONICS MASTER AND EMERGENCY SWITCH CIRCUIT. (Refer to Chapter 11, Figures 11-25 and 11-26.)

12-11. DESCRIPTION AND OPERATION. Electrical power for the various avionics components is controlled by the Avionics Master Switch located near the top of the instrument panel between the radio stacks. It controls the power to all radios through the aircraft master switch.

An emergency bus switch is also provided to provide auxiliary power to the avionics bus in the event of a radio master switch circuit failure. The emergency bus switch is located between the lower right shin guard left of the circuit breaker panel.

12-12. AUTOFLIGHT.

12-13. GENERAL. Due to the wide variety of A.F.C.S. (Automated Flight Control System) options, it is mandatory to follow the service literature published by the individual manufacturer of the A.F.C.S. equipment installed in any particular airplane. This includes mechanical service such as; adjusting bridle cable tension, servo removal & installation, servo clutch adjustments, etc.

12-14. NON-PIPER A.F.C.S. EQUIPMENT CONTACTS. Refer to the following list of Autopilot Flight Director manufacturers to obtain service direction, parts support, and service literature.

Bendix Avionics Division
2100 N.W. 62nd Street
Fort Lauderdale, Fla. 33310
(305) 776-4100/TWX 5109559884

Collins General Aviation Division
Rockwell International
Cedar Rapids, Iowa. 52406
(319) 395-3625 Telex: 464-421

Revised: 11/12/82

ELECTRONICS

2J4

PIPER SENECA II SERVICE MANUAL

Edo Corporation - Avionics Division
Box 610
Municipal Airport
Mineral Wells, Texas, 76067
(817) 325-2517 Telex: 76067

King Radio Corporation
400 North Rodgers Road
Olathe, Kansas, 66061
(913) 782-0400 Telex: 4-2299-Kingrad

Sperry Flight Systems/ Avionics Div.
8500 Balboa Blvd.
P.O. Box 9028
VanNuys, CA, 91409
(213) 894-8111 Telex: 65-1367

Global Navigation
2144 Michelson Drive
Irvine, CA. 92715
(714) 851-0119

12-15. PIPER A.F.C.S. EQUIPMENT. In the case of early models. Piper Autopilot equipment bears the Piper name, and the appropriate Piper Autopilot/ Flight Director Service Manual shall be used.

NOTE

If a Roll Axis-only Autopilot is installed, or if no Autopilot is installed, consult the Piper Pitch Trim Service Manual - 753 771 for manual electric pitch trim service information.

The following is a complete listing of Piper A.F.C.S. equipment service literature. It is imperative to correctly identify the Autopilot system by "faceplate" model name, in order to consult the appropriate service manual. Each manual identifies the revision level and revision status as called out on the Master Parts Price List - Aerofiche published monthly by Piper. Consult the aircrafts parts catalog for replacement parts.

NAME	PIPER PART NO.
AutoControl I/II & AltiMatic I/II	753 798
AutoControl III and AltiMatic III and IIIB	753 723
AutoControl IIIB and AltiMatic IIIB-1	761 502
AltiMatic IIIC	761 602
AltiMatic V and V-1	761 525
AltiMatic V F/D and V F/D-1	761 526
AltiMatic X F.D./ A.P. & X.A.P.	761 668
AutoFlite	753 720
AutoFlite II	761 481
Piper Pitch Trim (Manual-Electric)	757 771

SECTION XIII

HEATING AND VENTILATING SYSTEM

Paragraph		Aerofiche Grid No.
13-1.	Introduction	2J8
13-2.	Troubleshooting	2J8
13-3.	Description and Principles of Operation	2J8
13-4.	Combustion Heater (Janitrol)	2J10
	13-5. Heater System - Operational Test	2J10
13-6.	Description of Heater and Basic Components	2J11
	13-7. Spark-Spray Ignition	2J11
	13-8. Fuel Regulator and Shutoff Valve	2J11
	13-9. Duct Switch	2J14
	13-10. Combustion Air Blower	2J14
	13-11. Ventilating Air Blower	2J14
	13-12. Operating Controls	2J14
	13-13. Operating Procedure	2J15
	13-14. Maintenance Service	2J15
13-15.	Inspection of Heater and Heater Components	2J15
	13-16. Daily Inspection	2J15
	13-17. 100 Hour Inspection	2J17
	13-17a. Overhaul Instructions	2J17
	13-18. Removal of Heater (30,000 BTU)	2J18
	13-19. Installation of Heater (30,000 BTU)	2J18
	13-20. Removal of Heater (45,000 BTU)	2J19
	13-21. Installation of Heater (45,000 BTU)	2J19
13-22.	Heater Electrical System Checks	2J20
	13-23. Electrical Check	2J20
	13-24. Vent Blower Power Circuit Check	2J21
	13-25. Heater Power Circuit Check	2J21
13-26.	General Maintenance	2J23
	13-27. Combustion Air Blower	2J23
	13-28. Spark Plug	2J24
13-29.	Ignition Unit	2K3
	13-30. Ignition Unit Removal and Installation (30,000 BTU)	2K3
	13-31. Ignition Unit Removal and Installation (45,000 BTU)	2K3
	13-32. Testing Ignition Unit	2K4
	13-33. Operational Test of Ignition Unit	2K4
	13-34. Vibrator	2K4
	13-35. Vibrator Removal and Installation	2K4
	13-36. Inspection of Ignition Unit	2K5
13-37.	Cycling Switch and Limit (Overheat) Switch (30,000 BTU)	2K6
13-38.	Cycling Switch and Limit (Overheat) Switch (45,000 BTU)	2K6

Paragraph		Aerofic Grid No.
13-39.	Combustion Air Pressure Switch	2K7
13-40.	Fuel Regulator and Shutoff Valve	2K7
	13-41. Removal of Fuel Regulator	2K7
	13-42. Adjustment of Fuel Regulator	2K7
	13-43. Installation of Fuel Regulator	2K8
13-44.	Heater Fuel Pump Maintenance	2K8
	13-45. Removal of Heater Fuel Pump	2K8
	13-46. Disassembly of Pump	2K9
	13-47. Cleaning of Pump	2K9
	13-48. Inspection and Repair of Pump	2K9
	13-49. Assembly of Pump	2K10
	13-50. Installation of Heater Fuel Pump	2K10
13-51.	Duct Switch	2K10
13-52.	Overhaul Instructions	2K10
	13-53. Disassembly (30,000 BTU Heater)	2K11
	13-54. Disassembly of Combustion Air Blower Assembly (30,000 BTU)	2K12
	13-55. Cleaning	2K12
	13-56. Cleaning and Inspecting the Combustion Tube Assembly (30,000 BTU)	2K13
	13-57. Inspection of Remaining Components (30,000 BTU)	2K13
	13-58. Disassembly (45,000 BTU Heater)	2K15
	13-59. Disassembly of Combustion Air Blower Assembly (45,000 BTU)	2K16
	13-60. Cleaning	2K16
	13-61. Cleaning and Inspecting the Combustion Tube Assembly (45,000 BTU)	2K18
	13-62. Inspection of Remaining Components (45,000 BTU)	2K18
	13-63. Testing	2K19
	13-64. Repair of Combustion Tube Assembly	2K23
	13-65. Reassembly (30,000 BTU)	2K24
	13-66. Reassembly of Combustion Air Blower Assembly (30,000 BTU)	2L1
	13-67. Reassembly (45,000 BTU)	2L2
	13-68. Reassembly of Combustion Air Blower Assembly (45,000 BTU)	2L5
13-69.	Test Procedure	2L5
	13-70. General Information	2L5
	13-71. Equipment Required	2L7
	13-72. Operation Test (On Test Bench)	2L7
	13-73. Inspection of Fuel Nozzle Orifice	2L8
	13-74. Defroster Blower Removal and Installation	2L8

SECTION XIII

HEATING AND VENTILATING SYSTEM

13-1. INTRODUCTION. This section contains instructions for operating, servicing, inspecting and repairing the heater, defroster, and ventilating system installed in the PA-34-200T Seneca II. Particular attention should be given to ascertain that the particular heater being serviced is either the 30,000 BTU or 45,000 BTU unit. Most of the service information is basic to both units. Areas which differ have been clarified by the inclusion of the heater size in the particular subject headings.

13-2. TROUBLESHOOTING. A troubleshooting chart is located at the end of this section. The service troubles and suggested remedies found in this chart are provided to assist in locating and correcting possible malfunctions in the system.

13-3. DESCRIPTION AND PRINCIPLES OF OPERATION. Heated air for the cabin and defroster operation is obtained from the combustion heater located in the tail section of the airplane. Fresh air is supplied to the heater from an intake located in the dorsal fin and routed through the heater and into the cabin through six adjustable outlets. Operation of the heater is controlled by a three-position switch located on the heater control console between the pilot's and copilot's seats and labeled FAN, OFF and HEATER. The FAN position will operate the ventilation blower on the heater and may be used for cabin ventilation or windshield defogging on the ground when heat is not desired. There is a defroster blower in the same distribution system to provide additional defrost capability when required. The defroster control switch must be in the ON position to energize the defroster blower.

For cabin heat, the air intake lever located on the heater control console must be partially or fully open and the three-position switch set to HEATER. This will start the fuel flow and ignite the burner simultaneously. With instant starting and no need for priming, heat should be felt within a few seconds. There are two safety switches installed at the intake valve located aft of the heater unit which are activated by the intake valve and wired to prevent both fan and heater operation unless the air intake valve is moved off the closed position.

Regulating the heater and airflow is accomplished by adjusting the levers on the heater control console. The right-hand lever regulates the air intake valve, while the left-hand lever regulates cabin temperature. Cabin temperature and air circulation can be varied to suit individual requirements by various combinations of lever settings.

Heat may be supplied before starting the engines by turning on the master switch, opening the air intake valve, and placing the heater switch in the HEATER position.

An overheat limit switch is located in the forward outboard end of the heater vent jacket, which acts as a safety device to render the heater inoperative if a malfunction should occur. A red reset button on the switch can be reached through the bulkhead access panel into the aft fuselage; operation of this switch results in illumination of the overheat light located on the heater control console. To prevent activation of the overheat limit switch upon normal heater shutdown during ground operation, turn the switch to the FAN position for two minutes, while leaving the air intake lever in the open position, before turning the switch to the OFF position.

There are six overhead fresh air vents which are supplied by a separate inlet in the dorsal fin. This system can be supplemented by an optional blower.

An optional heater hourmeter is available on S/N 8170001 and up. It is located on the right hand side of the ignition unit.

PIPER SENECA II SERVICE MANUAL

1983

- 1. HEATER INLET
- 2. FRESH AIR INLET
- 3. OVERHEAD VENT BLOWER - OPTIONAL
- 4. COMBUSTION AIR BLOWER INLET
- 5. COMBUSTION HEATER ASSEMBLY
- 6. FRESH AIR OUTLETS
- 7. HEATER OUTLETS
- 8. DEFROSTER OUTLETS
- 9. DEFROSTER BLOWER
- 10. HEATER AND DEFROSTER CONTROL ASSEMBLY

ON S/N'S 34-807260 AND UP

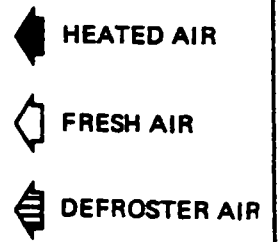
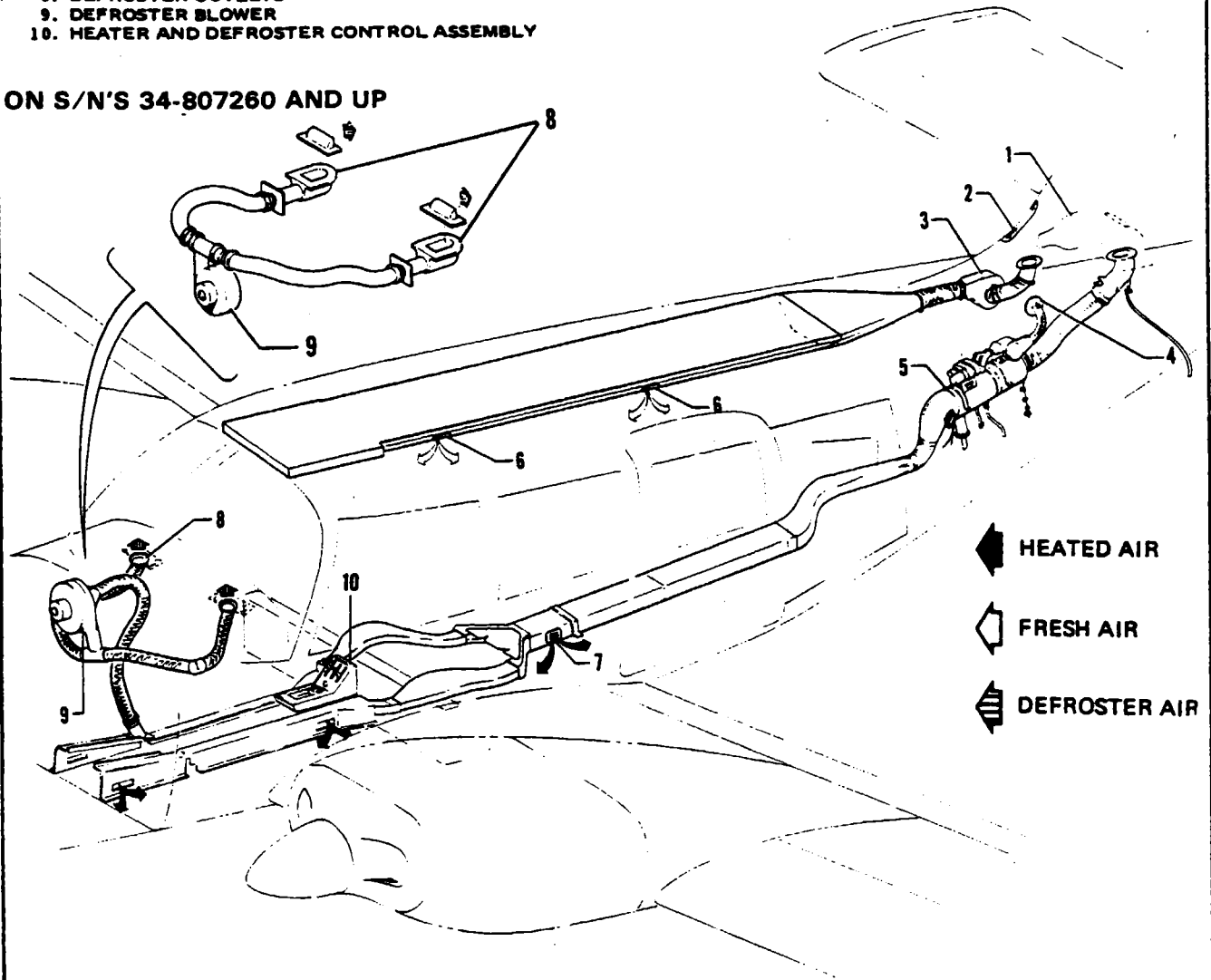

Figure 13-1. Cabin Heater, Defroster and Fresh Air Installation

13-4. COMBUSTION HEATER (JANITROL).

13-5. HEATER SYSTEM - OPERATIONAL TEST.

PPS6005E

- a. Check all fittings and connections for condition and security of mounting. Check all ducts, inlets and outlets for freedom from obstruction.
- b. Disconnect wire (H10A) from the heater terminal No. 2; this will remove electrical power to the fuel valve and pump.
- c. Turn the master switch and "HEATER" switch on and open the air intake valve. Both blowers (combustion air and ventilating air) should operate. Check at heater exhaust and ventilating air outlets to insure airflow. The heater should not ignite.
- d. With the aircraft on jacks, the ventilation blower shall stop operating with the gear in the gear up position. (This step may be accomplished during normal gear retraction tests provided steps a through d have been complied with first.)
- e. Press the overheat indicator light. It should illuminate.
- f. Place the air inlet lever in the open position and place the heater switch in the fan position for two minutes. Then place the heater switch in the off position.
- g. Place the master switch in the off position.
- h. Install a 0-10 psi pressure gauge at the fuel drain aft of the heater fuel pump, in the line from the fuel pump.
- i. Reconnect wire (H10A) to the heater terminal strip.
- j. Place the air intake lever in the open position and the temperature control lever in the center of its travel limits.
- k. Turn the master switch and the heater switch on. The heater should ignite and continue to operate until the thermostat causes it to stop operating. Cycling in this manner should continue until the heater switch is turned off.
- l. The pressure shown on the pressure gauge should be 7.5 ± 0.5 psi.
- m. Place the heater switch in the fan position. The heater should stop operating and the ventilation blower should continue to operate. Allow the blower to continue to operate for two minutes minimum. Then place the air intake lever in the closed position. The blower should stop operating.
- n. Turn the heater switch and master switch off.
- o. Remove the 0-10 psi pressure gauge and reconnect the fuel lines.
- p. Repeat steps i, j and e.

13-6. DESCRIPTION OF HEATER AND BASIC COMPONENTS.

13-7. SPARK-SPRAY IGNITION. (Refer to Figure 13-4.) The controlled atomized spray from a specially designed spray nozzle, coupled with high voltage spark plug ignition, insures instant firing and continuous burning under all flight conditions.

Heat is produced by burning a fuel-air mixture in the combustion chamber of the heater. Aviation gasoline is injected into the combustion chamber through the spray nozzle. The resulting cone-shaped fuel spray mixes with combustion air and is ignited by a spark from the spark plug. Electric current for ignition is supplied by an ignition unit which converts 14-volts to high voltage oscillating current to provide a continuous spark across the spark plug gap. A shielded, high voltage lead connects the ignition assembly to the spark plug. Combustion air enters the combustion chamber tangent to its surface and imparts a whirling or spinning action to the air. This produces a whirling flame that is stable and sustains combustion under the most adverse conditions because it is whirled around itself many times. Therefore, ignition is continuous and the combustion process is self-piloting. The burning gases travel the length of the combustion tube, flow around the inside of the inner tube, pass through crossover passages into an outer radiating area, then travel the length of this surface and out the exhaust.

Ventilating air passes through the heater between the jacket and combustion tube assembly outer surface and through an inner passage in the assembly. Consequently, ventilating air comes into contact with two or more heated cylindrical surfaces.

13-8. FUEL REGULATOR AND SHUTOFF VALVE. (Refer to Figure 13-5.) This unit provides preset, regulated fuel pressure as well as remove shutoff to the heater, regardless of fuel inlet pressure variations. It is set for $7.5 \pm .5$ psi. The shutoff valve is operated by a solenoid.

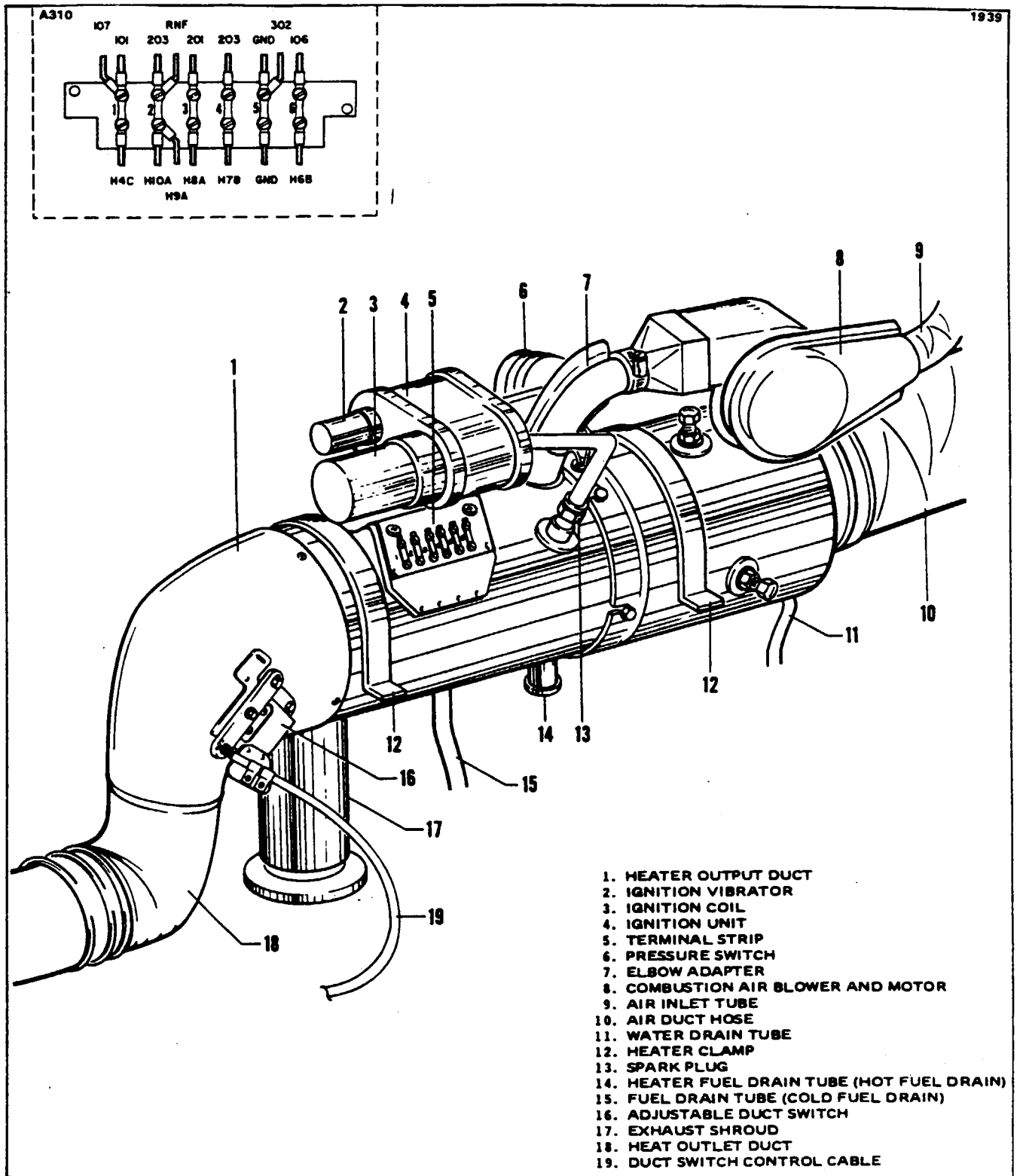
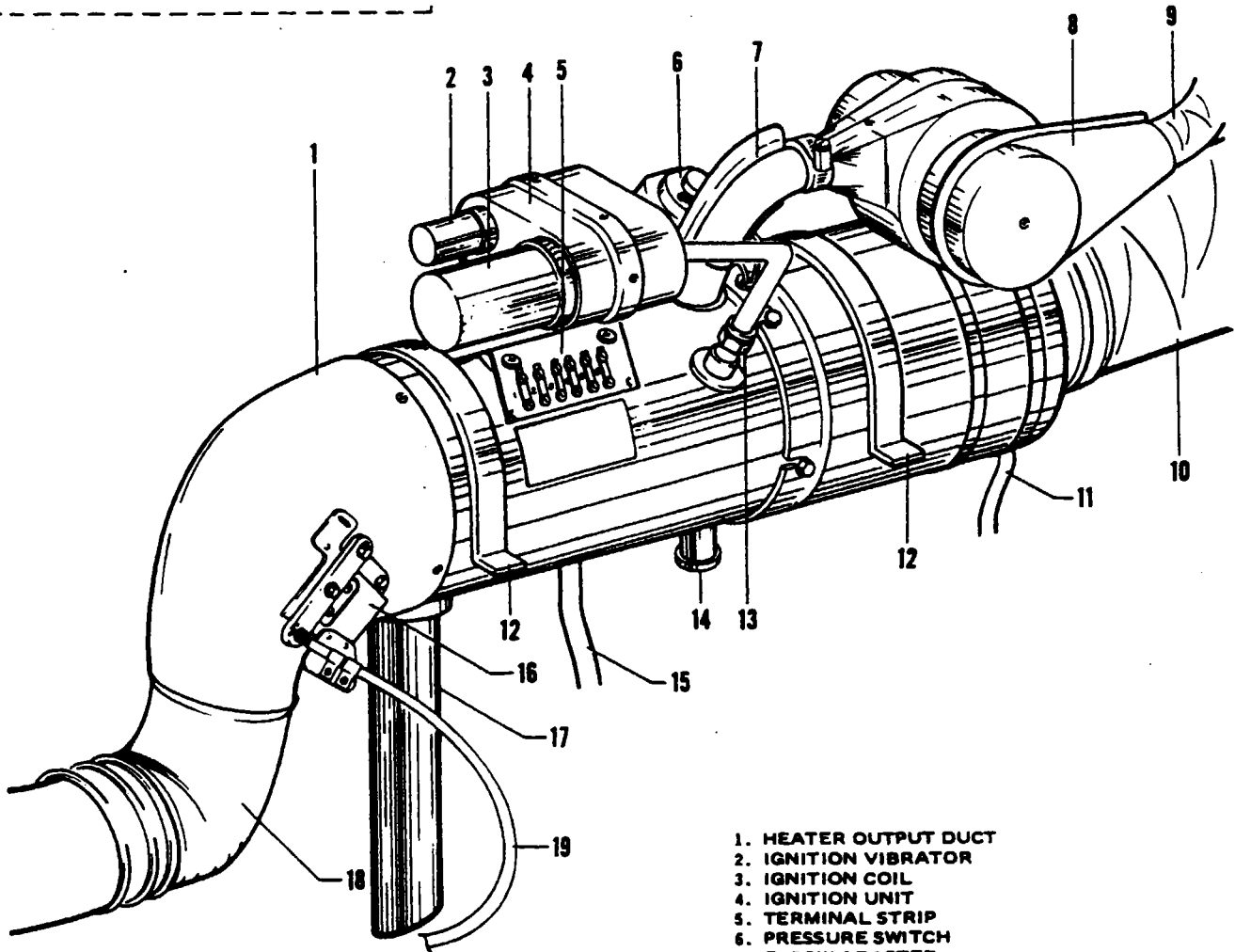
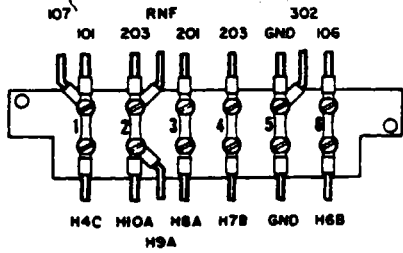

Figure 13-2. Heater and Combustion Air Blower Assembly (30,000 BTU)

PIPER SENECA II SERVICE MANUAL

1969



1. HEATER OUTPUT DUCT
2. IGNITION VIBRATOR
3. IGNITION COIL
4. IGNITION UNIT
5. TERMINAL STRIP
6. PRESSURE SWITCH
7. ELBOW ADAPTER
8. COMBUSTION AIR BLOWER AND MOTOR
9. AIR INLET TUBE
10. AIR DUCT HOSE
11. WATER DRAIN TUBE
12. HEATER CLAMP
13. SPARK PLUG
14. HEATER FUEL DRAIN TUBE (HOT FUEL DRAIN)
15. FUEL DRAIN TUBE (COLD FUEL DRAIN)
16. ADJUSTABLE DUCT SWITCH
17. EXHAUST SHROUD
18. HEAT OUTLET DUCT
19. DUCT SWITCH CONTROL CABLE

NOTE

HEATER HOURMETER (OPTIONAL ON S/N 81 70001 AND UP) LOCATED ON RIGHT HAND SIDE OF IGNITION UNIT.

Figure 13-3. Heater and Combustion Air Blower Assembly (45,000 BTU)

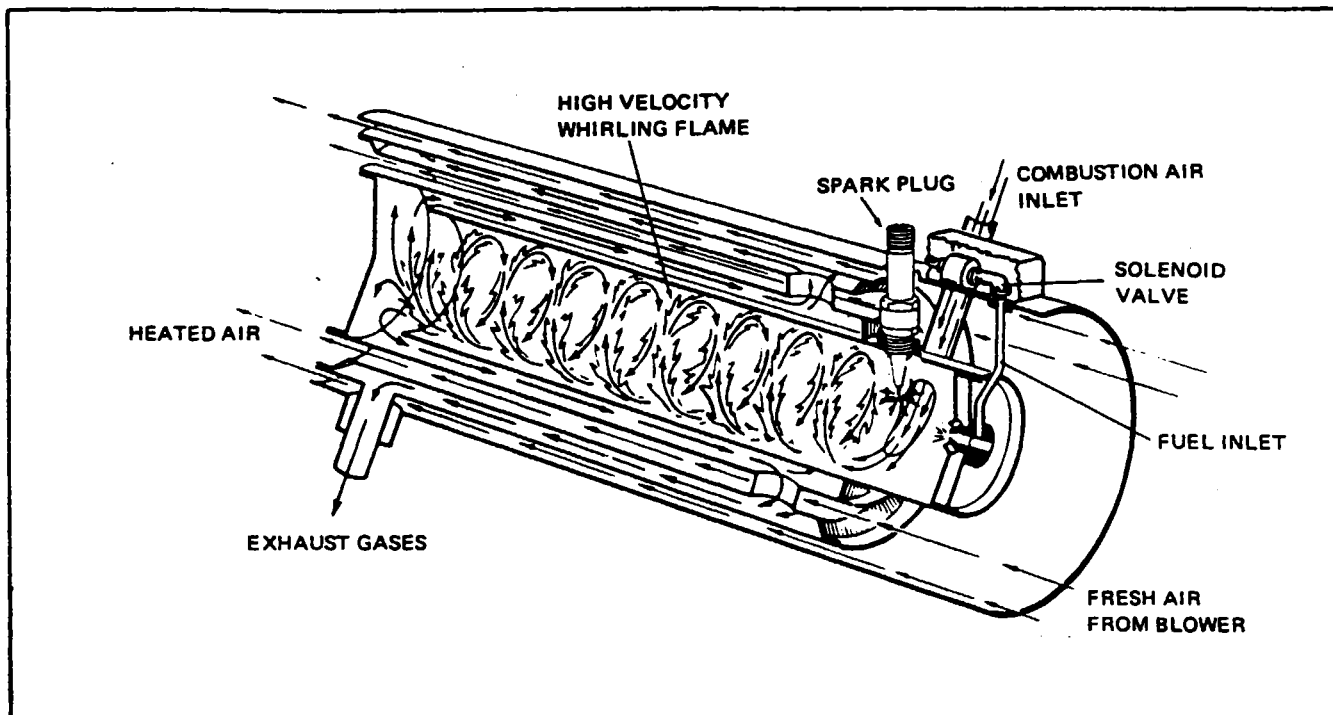

Figure 13-4. Diagrammatic Cutaway of Heater to Show Whirling Flame Action

13-9. DUCT SWITCH. (Refer to Figure 13-6.) This switch is installed in the ventilating air duct downstream from the heater to sense the ventilating air outlet temperature. To select the desired cabin temperature, the switch may be adjusted manually from a high of $250^{\circ}\text{F} \pm 10^{\circ}$ downward through a range of $146^{\circ}\text{F} \pm 6^{\circ}$. The switch has a differential of $15^{\circ}\text{F} \pm 5^{\circ}$ at any given setting.

13-10. COMBUSTION AIR BLOWER. This centrifugal type blower supplies combustion air to the combustion chamber of the heater.

13-11. VENTILATING AIR BLOWER. This blower is attached to the inlet end of the heater assembly and provides a source of ventilating air through the heater. Ram air from the ventilating air intake scoop is used during flight.

13-12. OPERATING CONTROLS. (Refer to Figure 13-7.)

NOTE

The schematic diagram (Figure 13-7) shows the heater circuit, including the electrical wiring in the airplane.

a. The HEATER SWITCH is connected in the line that supplied electrical power to all heater equipment and controls. When this switch is in the OFF position, the entire heater system is inoperative. This switch has a FAN position which permits use of the ventilating air blower to circulate cool air through the system for summer ground operation. With the switch in FAN position, the heater is inoperative and only the ventilating air blower is energized.

13-13. OPERATING PROCEDURE.

a. Place the master and heater switches in their "ON" position and place the air intake lever in the "OPEN" position. The ventilating air and combustion air blowers will operate and the heater will ignite.

NOTE

The blowers will not operate and the heater will not ignite with the air intake lever in the "CLOSED" position.

b. Set the temperature control lever to the desired temperature setting. This controls the duct switch.

NOTE

If this control is set for ground operating comfort, it may be necessary to reposition it after being airborne, since ram air will increase the ventilating airflow and heater output.

c. To stop the heater operation, turn the heater switch to the "FAN" position. The heater will shut off and the ventilating air blower will continue to operate. Allow the blower to operate for two minutes; this will cool down the heater before turning the heater switch off and closing the air intake valve. Refer to Paragraph 13-5 for complete operational test of the system. Turn off master switch.

13-14. MAINTENANCE SERVICE. Instructions contained in this section consist of periodic inspection, adjustments, and minor corrections required at normal designated intervals for the purpose of maintaining the heating system in peak operating condition. These inspections assume that a heating system includes accessory components mentioned in preceding paragraphs.

13-15. INSPECTION OF HEATER AND HEATER COMPONENTS.

a. Inspect all fuel lines and fittings for fuel stains, indicating leakage, and replace lines or tighten fittings as necessary.

b. Check heater for loose bolts, screws and wiring.

c. Inspect all electrical connections for corrosion. If corrosion is evident, clean affected components, and wipe with a lightly oiled cloth.

13-16. DAILY INSPECTION.

a. Inspect the ventilating air inlet scoop, combustion air inlet scoop, exhaust outlet and fuel drain for possible obstructions. Make sure that all of these openings are clear of any restrictions and that no damage has occurred to air scoop protrusions.

b. Look in the area of the combustion heater exhaust tube for large or unusual accumulation of soot on the aircraft skin. Soot accumulations indicate that the heater is operating at a "fuel rich" condition. A "fuel rich" condition may be caused by incorrect fuel pressure to the heater, restriction in the combustion air inlet line, loss of performance by the combustion air blower, or partially clogged fuel nozzle.

c. Perform an operational check as follows:

1. Place the HEATER SWITCH in the ON (or HEAT) position. The ventilating air blower and combustion air blower should operate and the heater OVER TEMP light should illuminate.

2. Operate both the combustion air blower and ventilating air blower and check each for unusual current draw, noise or vibrations.

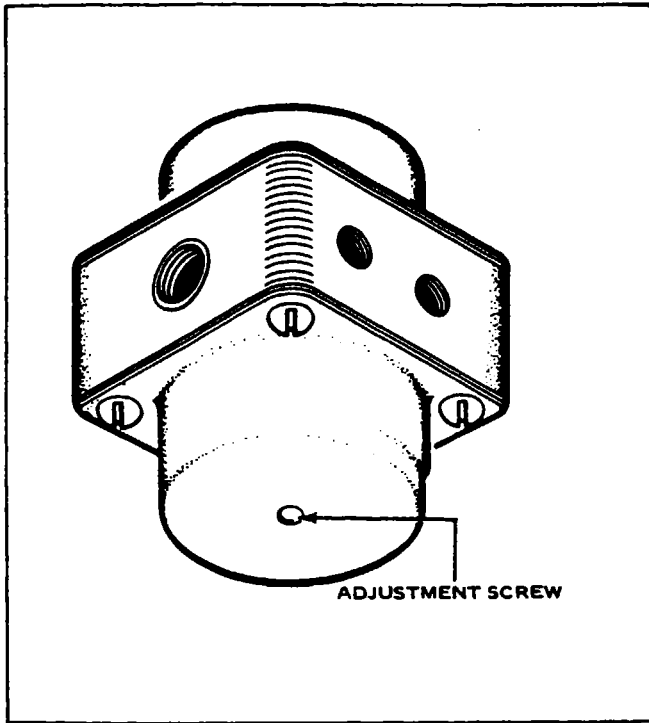

Figure 13-5. Fuel Regulator and Shutoff Valve

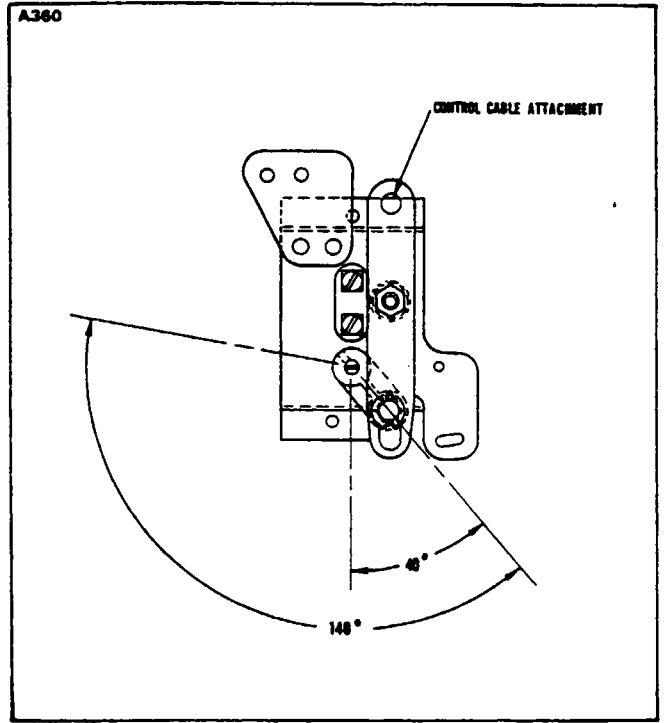

Figure 13-6. Top View - Duct Switch

THIS SPACE INTENTIONALLY LEFT BLANK

PIPER SENECA II SERVICE MANUAL

NOTE

To proceed with the operational check, follow paragraph entitled Operating Procedures, steps a through c. The above procedure should be repeated one or more times.

13-17. 100-HOUR INSPECTION. The mandatory 100-Hour Inspection shall be conducted on new heaters or overhauled heaters with a new combustion tube assembly upon accumulation of 500-heater operating hours or twenty-four months, whichever occurs first, and thereafter at intervals not to exceed 100-heater operating hours or twenty-four months, whichever occurs first. If an hourmeter is used on the heater assembly, it should be connected across terminals number 2 and 5 on the heater terminal strip. If an hourmeter is not used, count one heater operating hour for each two flight hours for normal aircraft operation. Consideration should be given for any excessive ground operation of the heating system.

NOTE

The 100-Hour Inspection consists of the functional checks and inspections listed below and the Pressure Decay Test.

- a. Inspect ventilating air and combustion air inlets and exhaust outlet for restrictions and security at the airplane skin line.
- b. Inspect the drain line to make sure it is free of obstructions. Run a wire through it if necessary to clear an obstruction.
- c. Check all fuel lines for security at joints and shrouds, making sure that no evidence of leaks exists. Also check for security of attachment of fuel lines at the various points in the airplane.
- d. Inspect electrical wiring at the heater terminal block and components for loose connections, possible chafing of insulation, and security of attachment points.
- e. Inspect the high-voltage cable connection at the spark plug to make sure it is tight. Also, examine the cable sheath for any possible indications of arcing, which would be evidenced by burning or discoloration of the sheath.
- f. Inspect the combustion air blower assembly for security of mounting and security of connecting tubing and wiring. Tighten any loose electrical terminals and air tube connections.
- g. Operate both the combustion and ventilating air blowers and check for unusual noise or vibrations.
- h. It is recommended that the condition of the spark plug be checked for operation as described in paragraph titled "Spark Plug."
- i. Evaluate the condition of the combustion chamber by performing a "Pressure Decay Test" as described in the latest revision of Janitrol Maintenance and Overhaul Manual P/N 24E25-1.
- j. Following the 100-hour inspection, perform the "Preflight and or Daily Inspection."

NOTE

Janitrol Maintenance and Overhaul Manual P/N 24E25-1 can be obtained from the Midland-Ross Corp., Janitrol Aero Division, 4200 Surface Road, Columbus, Ohio 43228. (Phone: 614-276-3561)

13-17a. OVERHAUL INSTRUCTIONS. The heater assembly shall be overhauled after 1000 hours or whenever the pressure decay test requirement cannot be met. The heater should be removed from the aircraft, disassembled, all parts thoroughly inspected and necessary repairs and or replacements made prior to reassembly. Detailed step-by-step instructions are included for a complete heater overhaul. In some instances, however, inspections may reveal that it is unnecessary to remove certain parts. If so, those portions of the overhaul procedures may be eliminated.

13-18. REMOVAL OF HEATER (30,000 BTU). (Refer to Figure 13-2.)

- a. Ascertain that all heater controls are off.
- b. Remove the access panel to the aft section of the fuselage.
- c. Disconnect the heater outlet hose from the heater air distribution box by releasing the hose attachment clamp.
- d. Disconnect the duct switch control cable from the left side of the air distribution box.
- e. Note the hookup of the electrical leads to facilitate reinstallation. Disconnect the leads from the heater terminal block.
- f. Disconnect the fuel supply line at the heater by removing the cover of the fuel line connection shroud and disconnecting the line from the solenoid valve.
- g. Disconnect the fuel and water drains from the bottom of the heater and allow them to slide down.
- h. Disconnect the air inlet hose from the inlet end of the heater by releasing the hose attachment clamp.
- i. Disconnect the combustion air blower inlet hose from the blower assembly by removing the cotter key and clevis pin at the blower.
- j. Loosen the clamps from around the heater and remove the heater from the airplane. The exhaust shroud should remain in the airplane.
- k. With the heater removed, the necessary maintenance may be performed as required.

13-19. INSTALLATION OF HEATER (30,000 BTU). (Refer to Figure 13-2.)

- a. Ascertain that all the heater components are on the heater. Position the exhaust tube shroud on the tube mounting flange located in the fuselage.
- b. Position the heater over its mounting brackets and ascertain that the exhaust tube extends into the exhaust shroud. Lower the heater to its mounting brackets. The exhaust tube should extend out the bottom of the fuselage.
- c. Move the heater slightly to obtain the best fit of the exhaust tube shroud and heater. Place the heater clamps around the heater and mounting bracket flanges and secure.
- d. Connect the combustion air blower inlet hose to the combustion air blower assembly on the heater and secure in place with the clevis pin and cotter key.
- e. Connect the air inlet hose to the inlet end of the heater and secure with clamp.
- f. Connect the fuel and water drain lines to the bottom of the heater.
- g. Connect the fuel supply line to the heater and cover over the fuel shroud and secure with four screws.

- h. Attach the duct switch control cable to the switch; refer to Paragraph 13-9 for complete rigging instructions.
- i. Connect the electrical leads to the heater terminal block on the heater as shown in Figure 13-2.
- j. Check the operation of the heater per instructions given in Paragraph 13-4.
- k. Install the access panel to the aft section of the fuselage.

13-20. REMOVAL OF HEATER (45,000 BTU). (Refer to Figure 13-3.)

- a. Ascertain that all heater controls are off.
- b. Remove the access panel to the aft section of the fuselage.
- c. Disconnect the heater outlet hose from the heater air distribution box by releasing the hose attachment clamp.
- d. Disconnect the duct switch control cable from the left side of the air distribution box.
- e. Note the hook up of the electrical leads to facilitate reinstallation. Disconnect the leads from the heater terminal block.
- f. Disconnect the fuel supply line at the heater by removing the cover of the fuel line connection shroud and disconnecting the line from the solenoid valve.
- g. Disconnect the fuel and water drains from the bottom of the heater and allow them to slide down.
- h. Disconnect the air inlet hose from the inlet end of the heater by releasing the hose attachment clamp.
- i. Disconnect the combustion air blower inlet hose from the blower assembly by removing the cotter key and clevis pin at the blower.
- j. Loosen the clamps from around the heater and remove the heater from the airplane. The exhaust shroud should remain in the airplane.
- k. With the heater removed, the necessary maintenance may be performed as required.

13-21. INSTALLATION OF HEATER (45,000 BTU). (Refer to Figure 13-3.)

- a. Ascertain that all the heater components are on the heater. Position the exhaust tube shroud on the tube mounting flange located in the fuselage.
- b. Position the heater over its mounting brackets and ascertain that the exhaust tube extends into the exhaust shroud. Lower the heater to its mounting brackets. The exhaust tube should extend out the bottom of the fuselage.
- c. Move the heater slightly to obtain the best fit of the exhaust tube shroud and heater. Place the heater clamps around the heater and mounting bracket flanges and secure.
- d. Connect the combustion air blower inlet hose to the combustion air blower assembly on the heater and secure in place with the clevis pin and cotter key.
- e. Connect the air inlet hose to the inlet end of the heater and secure with clamp.
- f. Connect the fuel and water drain lines to the bottom of the heater.
- g. Connect the fuel supply line to the heater and cover over the fuel shroud and secure with two screws.
- h. Attach the duct switch control cable to the switch. Refer to Paragraph 13-9 for complete rigging instructions.
- i. Connect the electrical leads to the heater terminal block on the heater as shown in Figure 13-3.
- j. Check the operation of the heater per instructions given in Paragraph 13-4.
- k. Install the access panel to the aft section of the fuselage.

PIPER SENECA II SERVICE MANUAL

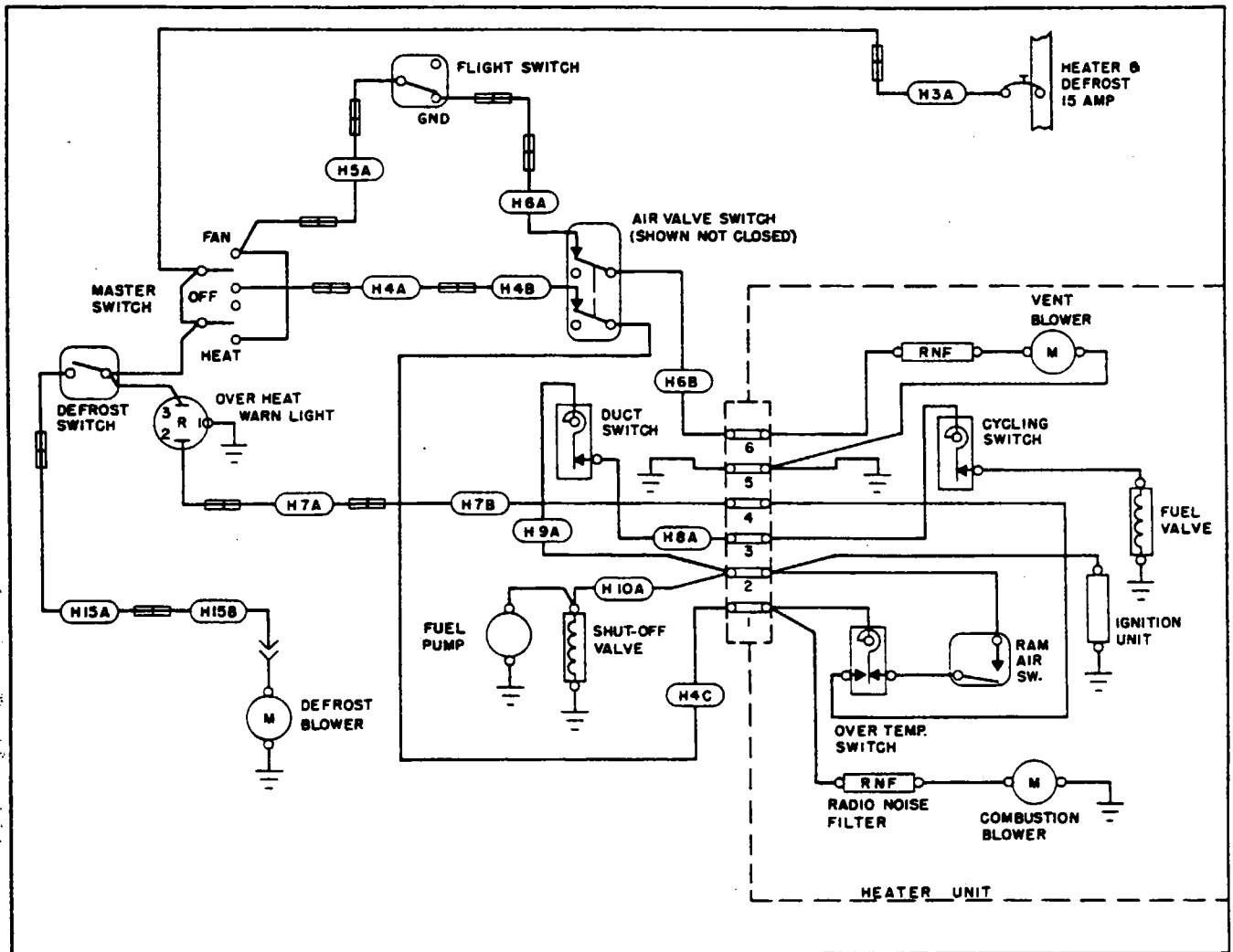

Figure 13-7. Wiring Diagram

13-22. HEATER ELECTRICAL SYSTEM CHECKS.

13-23. ELECTRICAL CHECK. These tests are listed as an aid in isolating open circuited or inoperative components.

NOTE

The schematic wiring diagram (Figures 13-7, 13-8 and 13-9) shows, in addition to the heater circuitry, the aircraft control circuit. For the purposes of this manual, the circuitry shown in these illustrations will be utilized to describe voltage checks.

It must be assumed that power, which is furnished through the heater circuit breaker, is present at the HEATER SWITCH at all times. Always check the circuit breaker before performing voltage checks.

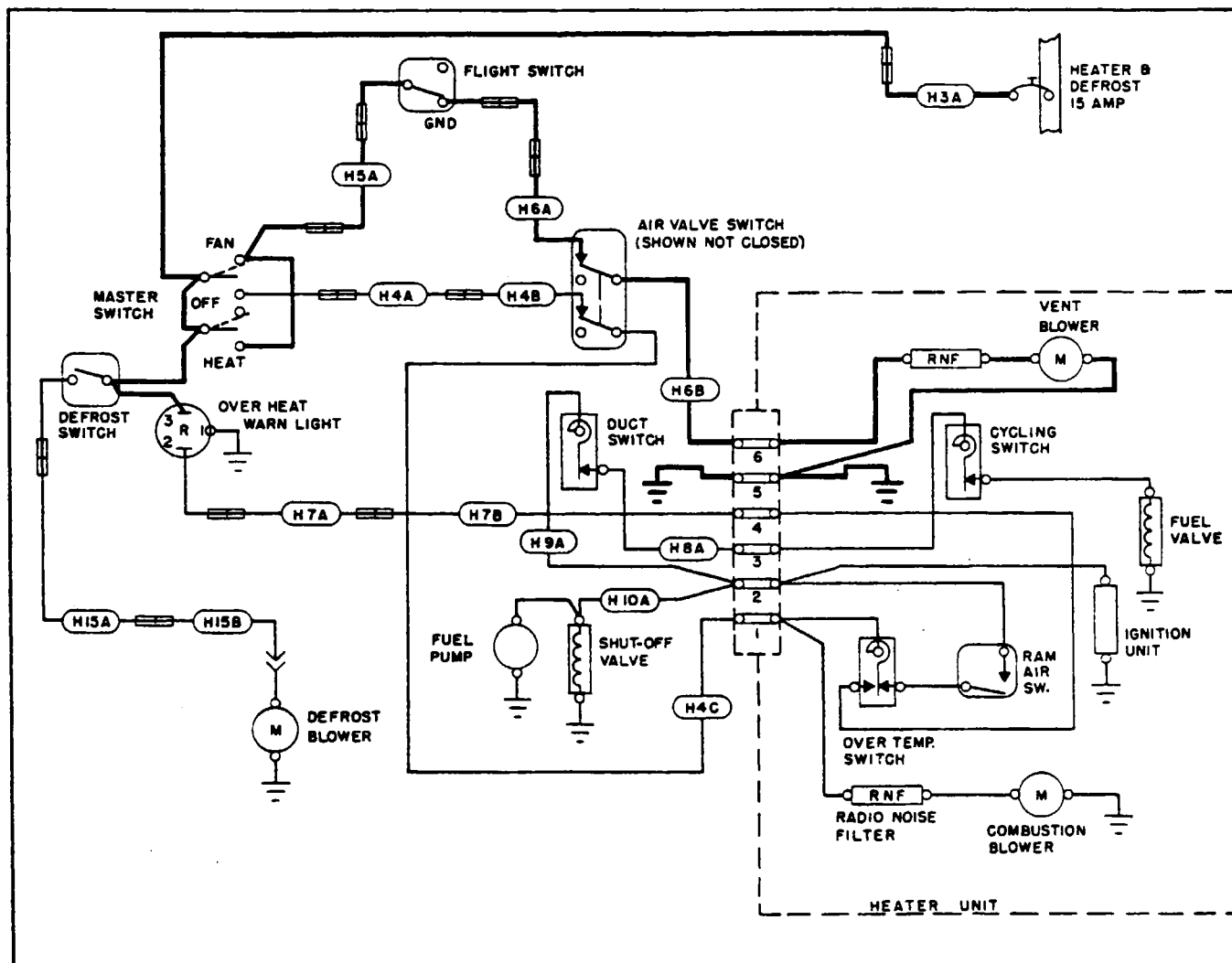

Figure 13-8. Primary Power Circuit

13-24. VENT BLOWER POWER CIRCUIT CHECK.

a. With the HEATER SWITCH in the FAN position, voltage (14-volts nominal) should be present at the following locations: (Refer to Figure 13-8.)

1. Terminal No. 6 on the heater terminal strip if the air valve is open.
2. From terminal No. 6 of the heater terminal strip through the radio noise filter to the ventilating air motor.
3. Electrical ground circuit for the ventilating air motor is provided from terminal No. 5 of the heater terminal strip. Ventilating air motor is inoperative when the landing gear is up or air valve is closed.

13-25. HEATER POWER CIRCUIT CHECK.

a. With the HEATER SWITCH in the HEAT position, voltage should be present at the following locations: (Refer to Figure 13-9.)

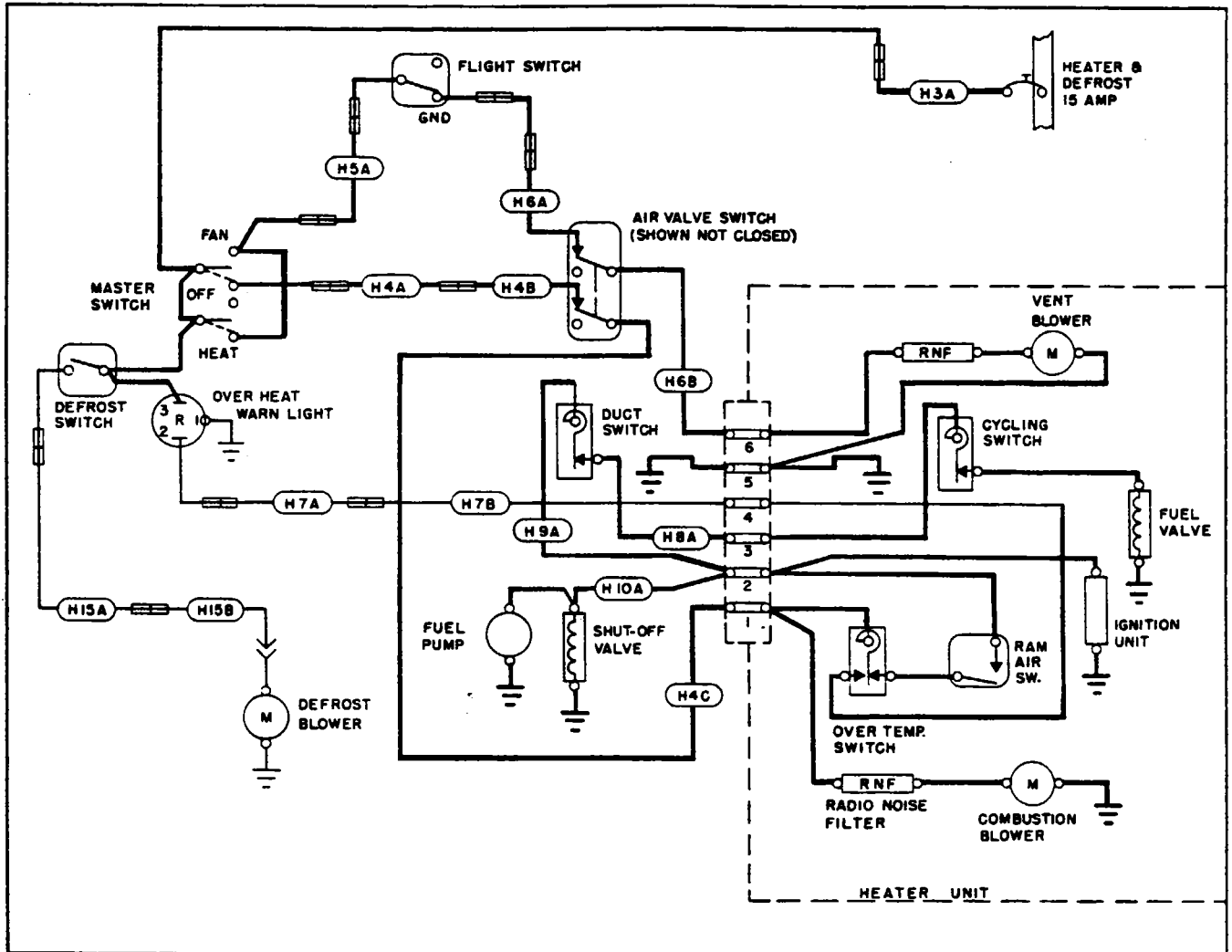

Figure 13-9. Starting Power Circuit

NOTE

Power for the ventilating air blower is the same as described above except that power is now supplied through the HEAT side of the HEATER SWITCH.

1. Terminal No. 1 of the heater terminal strip if the air valve is open.
2. From terminal No. 1 of the heater terminal strip through the radio noise filter to the combustion air motor and to terminal No. 1 of the overheat switch.
3. From terminal No. 3 of the overheat switch through the combustion air pressure switch to terminal No. 2 of the heater terminal strip.
4. From terminal No. 2 of the heater terminal strip to the ignition unit to the fuel regulator and shutoff valve and fuel pump through the adjustable duct switch to terminal No. 3 of the heater terminal strip.

PIPER SENECA II SERVICE MANUAL

5. From terminal No. 3 of the heater terminal strip through the cycling switch to the fuel solenoid valve.

In the event that voltage is not present at one or more of the above listed points, the wiring must be traced back to the power source. If components are still inoperative after the wiring inspection, check the individual inoperative components for voltage and, if necessary, replace them.

13-26. GENERAL MAINTENANCE. Instructions in this paragraph pertain to maintenance of the basic heater and components while the heater is installed in the airplane. Instructions for removal of components are included provided the installation permits accessibility.

NOTE

No special service tools are required for normal periodic maintenance.

13-27. COMBUSTION AIR BLOWER.

a. Removal:

1. Disconnect wire at quick-disconnect terminal.
2. Disconnect the inlet tubing from the inlet air adapter.
3. Loosen the clamps that hold the combustion air blower assembly in the support bracket and slide the motor out of the bracket.

b. Replacing Motor Brushes: (Refer to Figure 13-20 or 13-21.)

1. Remove the brush cap at one of the brush locations. Note position of brush inside the guide and carefully lift the brush and brush spring out of the guide. Be sure to hold the brush so that it can be reinstalled in precisely the same position if no brush replacement is required.

2. Inspect the brush for wear. If brushes are worn to a length of .187 of an inch, they must be replaced.

3. Looking through the brush guide, inspect the commutator which should be smooth and medium brown to dark brown in color. Remove all dust from commutator with compressed air. If the commutator is grooved in the brush track, gouged, scored or shows signs of having burned spots, replace the complete motor assembly. If the commutator is in good condition, install new motor brushes and tighten brush caps into place. Make sure each brush is oriented so that the curved end fits the curvature of the commutator.

4. After installing new brushes, it is advisable to run in the brushes as follows: Connect the motor to a controlled voltage supply (rheostat in a 14-volt line). Operate the motor at approximately 1/2 its normal speed for the first hour; then gradually increase the speed until it is rotating at approximately normal speed. Continue the run in operation for at least two hours to properly seat the brushes before installing the blower in the aircraft.

c. Installation:

1. Prior to installing the combustion air blower, inspect all parts of the assembly for loose screws, loose nuts, and poor ground connection on the blower housing. Make sure the blower wheel is tight on the shaft and properly located in the housing. It should have just enough clearance to rotate at full speed without binding against the inlet housing. Blower performance is based upon this close-tolerance clearance. It is recommended that correct voltage be applied for this clearance check.

2. Install the blower inlet adapter in the same orientation as before removal.

3. Place the combustion air blower assembly in position in the attaching clamp so the air tubing can be connected and slide the tubing into position at the point where it was disconnected during removal. Do not tighten until after tightening the motor in the attaching strap.

4. Tighten the blower motor mounting strap securely making certain the air tubing is in proper alignment.

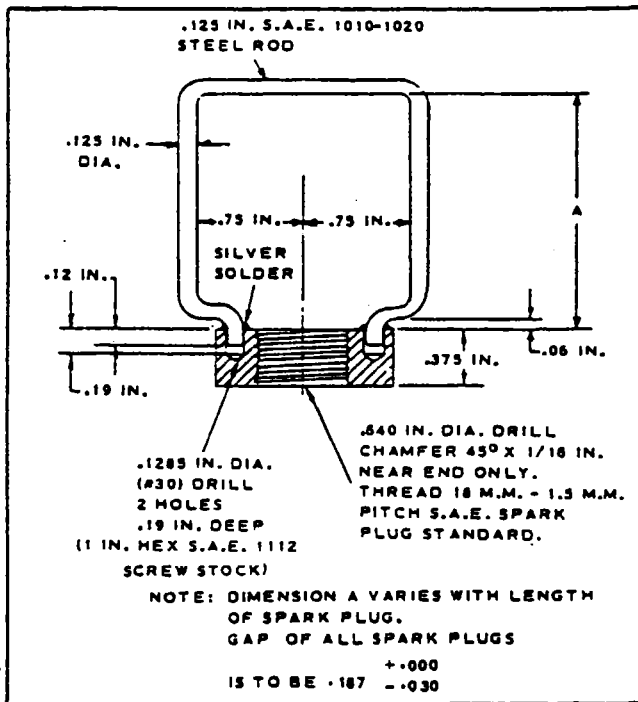

Figure 13-10. Spark Plug Fixture

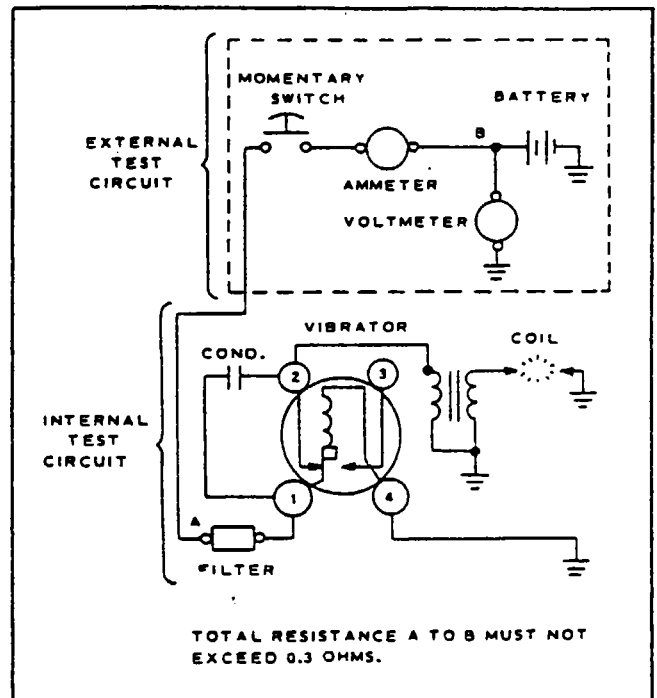

Figure 13-11. Wiring - Test Setup

5. Secure the air tubing by tightening the clamp or installing the sheet metal attaching screws.
6. Connect the wire lead at the quick-disconnect terminal.
7. Connect the ground lead securely to the mounting bracket.
8. Check motor operation. By disconnecting the wire at the No. 3 terminal on heater terminal strip, blower can be operated without fuel flow to the heater.

13-28. SPARK PLUG.

a. Removal: (Refer to Figure 13-18 or 13-19.)

1. Remove the necessary access panels to expose the spark plug area of the heater assembly.

NOTE

Insure that heater electrical circuits are de-energized.

2. Unscrew and remove the high voltage lead connector at the spark plug. Exercise care to avoid fouling or damaging the connector.
3. Remove the grommet (39).
4. Using a 7/8 inch deep hex socket, unscrew and remove the spark plug (32). Make sure the spark plug gasket is removed with the spark plug. It will normally stick on the spark plug threads, but if gasket should drop into the ventilating air passages of the heater, remove with a wire hook.

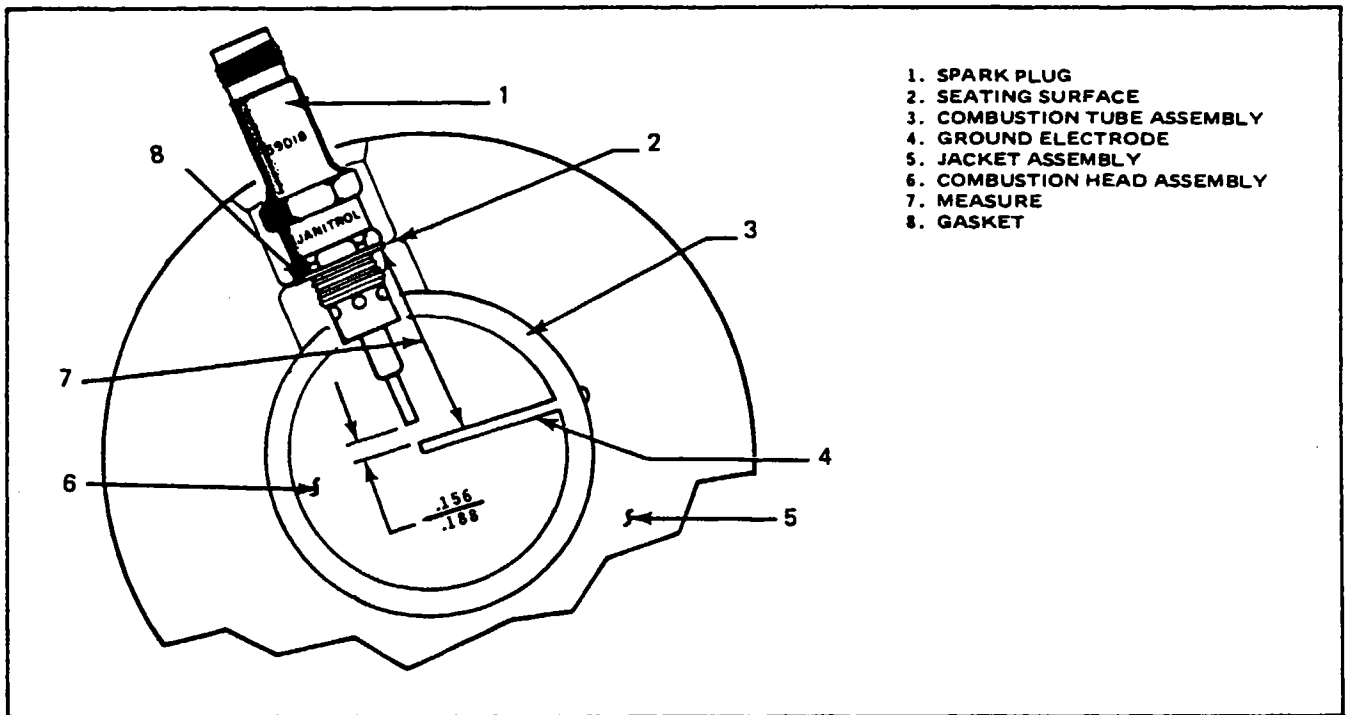

Figure 13-12. Spark Plug Gap Adjustment

b. Inspection and Servicing (Spark Plug):

1. If the spark plug appears to be in good condition, except for a mild coating of oxide on the porcelain and electrodes, it may be cleaned and reused. Cleaning is accomplished on a conventional airplane type spark plug cleaner, except that it will be necessary to use two or more adapters in order to raise the long extension of the plug far enough out of the cleaner nozzle opening to perform an effective job. Plug the ceramic insert cavity at the terminal end of the plug with a piece of paper or cloth to keep out any of the cleaning sand. Wipe this cavity out thoroughly with a cloth wet with carbon tetrachloride. If after cleaning the spark plug porcelain is white and the electrodes are not eroded, proceed to check the ground electrode in the heater and adjust the spark gap in accordance with Step c of this paragraph.

NOTE

If the spark plug fails to clean up properly and/or if the electrodes are badly eroded, it should be replaced.

c. Spark Gap Check and Adjustment: (See Figure 13-12.) A spark gap of 0.156 to 0.188 inches must be maintained on the P/N 39D18 spark plug. This gap should be checked any time a plug is replaced or at the time of heater overhaul. A spark gap greater than that specified can shorten the life of the ignition assembly. There are several methods in which the spark gap of this heater may be checked. Method I is recommended when the heater is being overhauled and before the installation of the fuel nozzle. Methods II and III are suitable for checking the gap through the spark plug well when the heater is not disassembled.

PIPER SENECA II SERVICE MANUAL

Method I:

1. Using a 5/32 inch drill (0.156) or a piece of 5/32 rod, reach down through the small opening in the combustion head and find the ground electrode. (It is welded inside the head.)
2. Move the drill along the side of the electrode on the spark plug side. (Movement should be from the outer edge towards the center.) The drill should just pass through the spark plug gap opening. Should the drill fail to pass through this opening, the gap is too narrow. If it passes through too freely, the gap is too wide. In either case, it will be necessary to bend the ground electrode in the direction required. This may be done by removing the spark plug and reaching through the opening.
3. Recheck the gap after repositioning of the ground electrode.

Method II:

1. Measure the distance between the seating surface of the spark plug with a new gasket installed to the end of the plug electrode.
2. Using a depth gauge, measure the distance between the ground electrode in the heater to the spark plug seating surface in the heater jacket and check this measurement against the measurement obtained in Step 1. The difference should be between 0.156 to 0.188 of an inch.
3. The ground electrode can be bent to obtain the required gap.

Method III:

1. Fabricate or purchase from Piper the special tool from dimensions given in Figure 13-24.
2. Install the threaded end of the tool into the spark plug hole.
3. Slide the rod of the tool into the combustion head until it contacts the ground electrode.
4. Check that the indicator ring on the rod lines up with the end of the tool. The ground electrode may be bent to obtain the required gap.

NOTE

Inspect the ground electrode for erosion. If it is eroded to approximately half of its original 1/8 inch diameter, it should be replaced. This can be done as follows:

- (a) Grind off the head of the rivet where it projects through the combustion head and remove the electrode.
- (b) Install a new CRES rivet AN125452 which is 1.500 inches in length.
- (c) Heliarc tack weld the rivet head to hold it in place.
- (d) Check spark gap as noted in Methods I or II.

d. Installation: (Refer to Figure 13-12.)

1. If a new spark plug is being installed, be sure to adjust the spark gap as outlined in Step c of this paragraph. Do not bend the electrode on the spark plug.
2. Place a new spark plug gasket on the threads. If the gasket does not hold on the threads and would be likely to fall off during installation, place a small drop of Aviation Permatex or similar material on the gasket to stick it temporarily to the plug shell.
3. Screw the spark plug into the heater with a deep socket wrench. Tighten to a torque of 28 foot-pounds.
4. Install the grommet (39, Figure 13-18 or 13-19) in the heater jacket opening.
5. Carefully insert the spring connector on the high voltage lead into the spark plug shell; press down gently and start the nut on the threads. Tighten the nut to 20 foot-pounds.
6. Operate the heater to check dependability and close all access openings.

13-29. IGNITION UNIT. This unit converts 14-volt DC to high voltage, oscillating current capable of producing a continuous spark in the combustion chamber of the heater. This unit remains energized and produces a continuous spark during heater operation. It contains a condenser, resistor, radio noise filter and vibrator socket. It also has an externally mounted vibrator and ignition coil.

13-30. IGNITION UNIT REMOVAL AND INSTALLATION (30,000 BTU).

- a. Removal: (Refer to Figure 13-18.)

NOTE

Make sure heater electrical circuits are de-energized.

1. Disconnect the primary wire from the primary terminal of the ignition assembly (2).
2. Carefully unscrew and disconnect the high voltage ignition cable at the spark plug. Exercise care to avoid fouling or damaging the connector.
3. Remove the four attaching screws and lock washers and lift the ignition assembly (2) off the mounting brackets on heater jacket.

- b. Installation: (Refer to Figure 13-18.)

1. Place the ignition assembly in position on the brackets attached to the heater jacket with the high voltage cable facing the spark plug end of the heater.
2. Install the four screws and lock washers. Tighten the screws securely.
3. Carefully connect the high voltage lead to the spark plug. (Refer to Paragraph 13-28, c.)
4. Connect the primary lead to the primary terminal on the ignition unit (2) and tighten the nut securely.
5. Check for proper heater operation.

13-31. IGNITION UNIT REMOVAL AND INSTALLATION (45,000 BTU).

- a. Removal: (Refer to Figure 13-19.)

NOTE

Make sure heater electrical circuits are de-energized.

1. Disconnect the primary wire from the primary terminal of the ignition assembly (2).
2. Carefully unscrew and disconnect the high voltage ignition cable at the spark plug. Exercise care to avoid fouling or damaging the connector.
3. Remove the four attaching screws and lift the ignition assembly (2) off the heater jacket.

- b. Installation: (Refer to Figure 13-19.)

1. Place the ignition assembly in position on the heater jacket with the high voltage cable facing the spark plug end of the heater.
2. Install the four screws. Tighten the screws securely.
3. Carefully connect the high voltage lead to the spark plug. (Refer to Paragraph 13-28, c.)
4. Connect the primary lead to the primary terminal on the ignition unit (2) and tighten the nut securely.
5. Check for proper heater operation.

PIPER SENECA II SERVICE MANUAL

13-32. **TESTING IGNITION UNIT.** The ignition unit does not require complete overhaul. The following test will indicate whether or not the unit is operational and whether the vibrator should be replaced before reinstallation in the aircraft. The following equipment is required to test the components:

- a. A battery that will supply power at approximately 14-volts DC.
- b. A voltmeter with a range of 0-15-volts.
- c. A lead from the battery to the test fixture in which is included an ammeter with a range of 0-3 amperes and a normally open, momentary-closed switch. The total resistance of the lead including the ammeter and switch must not exceed 0.3 ohms.
- d. A spark gap of 0.187 inch (plus 0, minus .030). A convenient means of arranging the correct spark gap is to install a spark plug, P/N 39D18, in a test fixture arranged to provide a ground electrode and a .187 inch spark gap. (Refer to Figure 13-10 for information on fabricating this fixture.)

NOTE

Any one of several spark plugs may be used with the spark plug fixture detailed in Figure 13-10. However, the "A" dimension in that sketch must be varied with the length of spark plug electrode to provide a gap of .187 inch for all spark plugs.

CAUTION

When testing an ignition unit, do not use a screwdriver as a substitute for a spark plug and spark plug fixture.

- e. The high tension shielded ignition lead between the ignition unit and the spark plug is a part of the cover assembly.
- f. Arrange the test equipment as shown in Figure 13-11.

13-33. **OPERATIONAL TEST OF IGNITION UNIT.**

- a. Close the momentary switch and read the voltmeter and ammeter. Release the momentary switch immediately.
- b. The amperage reading at 14-volts DC must be 1.50 ± 0.25 amperes.

13-34. **VIBRATOR.** The vibrators should be replaced after 250 hours of operation. This schedule applies equally to vibrators installed in new units as well as new vibrators installed in ignition units that have been in service.

13-35. **VIBRATOR REMOVAL AND INSTALLATION.** (Refer to Figure 13-13.)

- a. Remove the clamp.
- b. Remove the vibrator (5) from the ignition unit; it may require a slight back-and-forth movement to remove it from the unit. A piece of masking or friction tape around the exposed portion of the vibrator will help to grip the vibrator for removal.
- c. Install the new vibrator with the index marks aligned. The connector pins on the vibrator can be felt entering the pin sockets in the vibrator socket; then press the vibrator fully and firmly into position. Secure with the clamp.

NOTE

If replacement of vibrator fails to correct operational failure, further disassembly and inspection may be required.

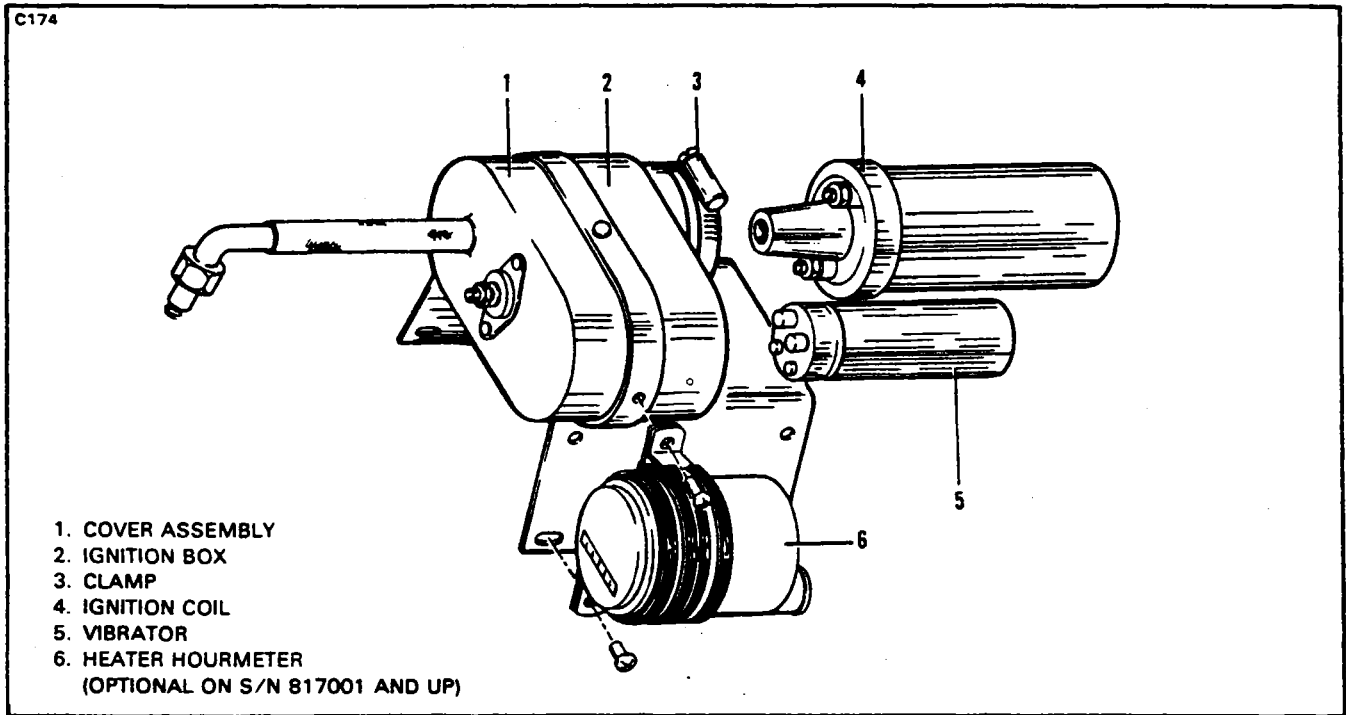

Figure 13-13. Ignition Unit Assembly

TABLE XIII-I. INSPECTION (See Figure 13-13)

Index No.	Nomenclature	Inspection
1	Cover Assembly	Inspect for security of lead assembly to cover. Ignition cable, grommet, terminal and connector for carbon tracks, cracks or distortion. Repair or replace for any of above conditions.
4	Ignition Coil	Inspect for broken bakelite, carbon tracks, oil leaks, and dents in coil cover. Replace for any of the above conditions.

13-36. INSPECTION OF IGNITION UNIT. Inspect components as directed in Table XIII-I and Figure 13-13.

NOTE

Replace any component that fails to meet checks listed in Table XIII-I.

13-37. CYCLING SWITCH AND LIMIT (OVERHEAT) SWITCH (30,000 BTU HEATER). (Refer to Figure 13-18.)

a. Removal:

1. If the limit switch (25) is damaged or defective, disconnect the three electrical leads from the switch terminals. Be sure to mark the leads for proper reassembly. (The switch terminals are identified by numbers "1," "2," and "3.")
2. Remove the two attaching screws, lock washers and plain washers, and lift the limit switch (25) and spacers (gaskets) (27) from the jacket opening.
3. If the cycling switch (24) is damaged or defective, disconnect the electrical leads being sure to mark them for proper reassembly.
4. Remove the two screws, lock washers and plain washers, and lift the cycling switch (24) from the jacket opening.

NOTE

No attempt should be made to repair either of these switches. If they do not operate properly, they should be replaced. (Refer to Paragraph 13-51, m and n for test instructions.)

b. Installation: (Refer to Figure 13-18.)

1. Install the limit switch (25) and spacers (gaskets) (27) by placing them in position in the heater jacket opening and installing two screws, lock washers and plain washers.
2. Tighten screws securely; then reconnect the electrical leads in accordance with markings made during disassembly. (Refer to wiring diagram, Figure 13-7.)
3. Install the cycling switch (24, Figure 13-18) by placing it in position in the heater jacket opening and securing it with the two screws, lock washers and plain washers. Tighten screws securely; then reconnect the electrical leads to their respective terminals as marked during disassembly. (Refer to wiring diagram, Figure 13-7.)

13-38. CYCLING SWITCH AND LIMIT (OVERHEAT) SWITCH (45,000 BTU HEATER). (Refer to Figure 13-19.)

a. Removal:

1. If the limit switch (25) is damaged or defective, disconnect the three electrical leads from the switch terminals. Be sure to mark the leads for proper reassembly. (The switch terminals are identified by numbers "1," "2" and "3.")
2. Remove the two attaching screws and lift the limit switch (25) and spacers (gaskets) (27) from the jacket opening.
3. If the cycling switch (24) is damaged or defective, disconnect the electrical leads being sure to mark them for proper reassembly.
4. Remove the two screws and lift the cycling switch (24) from the jacket opening.

NOTE

No attempt should be made to repair either of these switches. If they do not operate properly, they should be replaced. (Refer to Paragraph 13-72, m and n for test instructions.)

- b. Installation: (Refer to Figure 13-19.)
1. Install the limit switch (25) and spacers (gaskets) (27) by placing them in position in the heater jacket opening and installing two screws.
 2. Tighten screws securely; then reconnect the electrical leads in accordance with markings made during disassembly. (Refer to wiring diagram, Figure 13-7.)
 3. Install the cycling switch (24, Figure 13-19) by placing it in position in the heater jacket opening and securing it with the two screws. Tighten screws securely; then reconnect the electrical leads to their respective terminals as marked during disassembly. (Refer to wiring diagram, Figure 13-7.)

13-39. COMBUSTION AIR PRESSURE SWITCH. (Refer to Figure 13-18 or 13-19.)

- a. Removal:
1. Disconnect electrical leads from the terminals of the combustion air pressure switch (26), being sure to mark them for proper reassembly. Disconnect the tube from the switch cap. Exercise caution not to exert excessive bending of the tube. (It is "tacked" to the combustion chamber inside the jacket.)
 2. Unscrew and remove the combustion air pressure switch from the fitting on the combustion air inlet tube.
- b. Installation:
1. Install the combustion air pressure switch (26) by rotating it on the threaded fitting of the combustion air inlet tube and tighten it securely. Exercise caution not to over-torque the switch as this could change the setting.
 2. Connect electrical leads to their respective terminals in accordance with markings made during removal. If in doubt regarding proper connections, refer to the wiring diagram, Figure 13-6. Connect the tube to the switch cap.
 3. Check for proper heater operation.

13-40. FUEL REGULATOR AND SHUTOFF VALVE. (Refer to Figure 13-1.) The fuel regulator and shutoff valve is located below the floor panel between the main and rear spar on the right side of the cabin. It is enclosed in a special fiberglass box with a removable access panel.

13-41. REMOVAL OF FUEL REGULATOR.

- a. Ascertain that the left fuel tanks are empty and the fuel selector controls are in the OFF position.
- b. Gain access to the regulator and disconnect the electrical leads from regulator and shutoff valve.
- c. Disconnect the fuel line from the outlet port and remove the regulator from the heater fuel pump. Cap all open fuel lines to prevent contamination.

13-42. ADJUSTMENT OF FUEL REGULATOR. The fuel regulator and shutoff valve used in this system is adjustable but not repairable. The following steps cover the proper adjustment of this unit:

- a. Install the regulator in a test stand similar to that shown in Figure 13-14.
- b. Install a 2.0 gph nozzle (Janitrol Part No. C08D09). Gasoline or Stoddard solvent can be used for testing.
- c. Apply fluid pressure from fuel pump and energize the solenoid. Outlet pressure should be $7.0 \pm .5$ psi, if not, correct accordingly.
- d. Using a screwdriver, break the seal over the adjustment screw and adjust the regulated outlet pressure to $7.0 \pm .5$ psi. (Turn clockwise to increase pressure or counterclockwise to decrease pressure.)
- e. De-energize and energize the solenoid at least twice. The outlet pressure should be 6.5 to 7.5 psi with the solenoid energized. When the solenoid is de-energized, the pressure should drop to zero and the fuel flow from the nozzle should stop.
- f. During the above test, observe for signs of external leakage. Any leakage is cause for rejection of the regulator. After satisfactory adjustment has been made, apply Glyptol around the threads of the adjustment screw and in the slot.

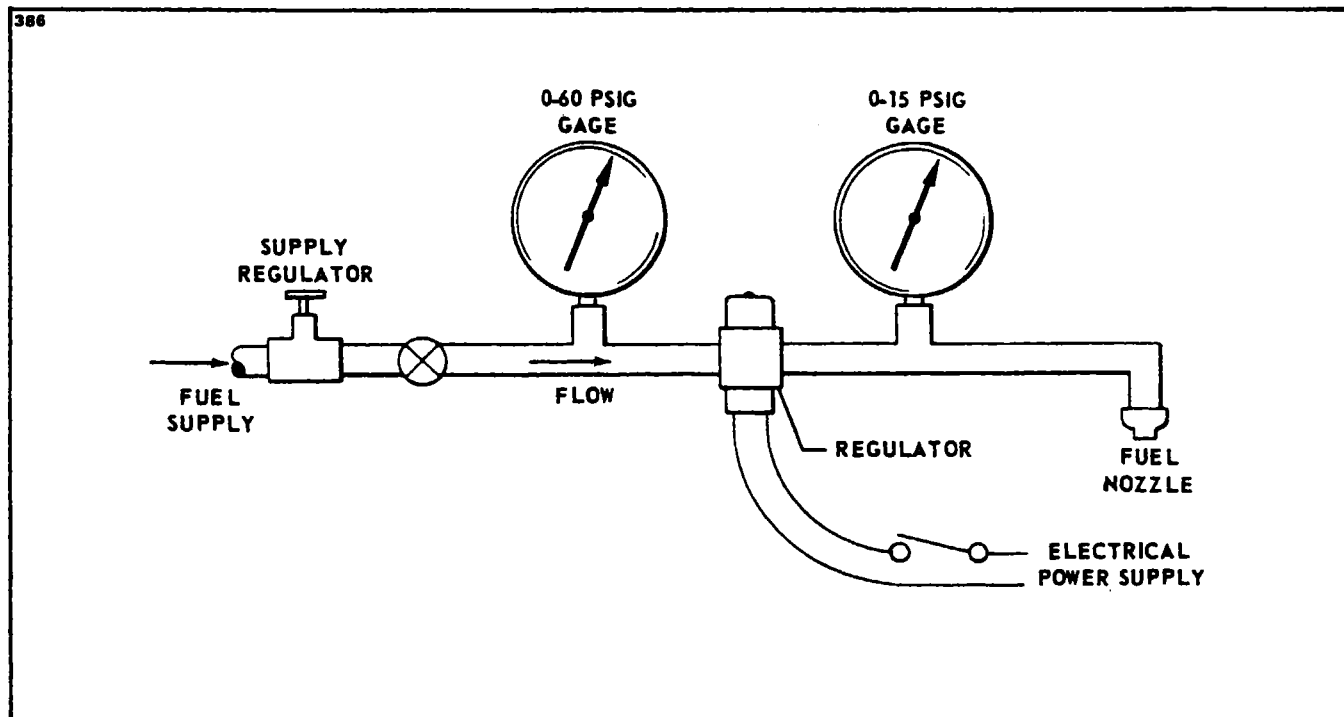

Figure 13-14. Test Setup for Fuel Regulator and Shutoff Valve

13-43. INSTALLATION OF FUEL REGULATOR.

- a. Position the regulator into position between the fuel line and fuel pump. Ascertain that the inlet side of the regulator is towards the fuel pump.
- b. Connect the regulator to the pump and the heater fuel line to the regulator outlet port.
- c. Connect the electrical leads from the regulator.
- d. Operate the heater to make sure the unit is functioning properly. (Refer to Paragraph 13-5, Heater System - Operational Test.)

13-44. HEATER FUEL PUMP MAINTENANCE. (Refer to Figure 13-15.) The maintenance required for this type of fuel pump is very limited, consisting of inspection and replacing parts that are worn or broken.

13-45. REMOVAL OF HEATER FUEL PUMP. The heater fuel pump is located below the cabin floor panel between the main and rear spar on the right side of the cabin. It is enclosed in a fiberglass compartment which has a removable access cover.

- a. Ascertain that the left fuel tanks are empty and the fuel selector controls are in the OFF position.
- b. Disconnect the electrical lead from the pump.
- c. Disconnect the fuel line from the inlet end of the pump and the regulator from the outlet end. Cap all open fuel lines to prevent contamination.
- d. Remove the bolts which secure the pump to its mounting bracket.

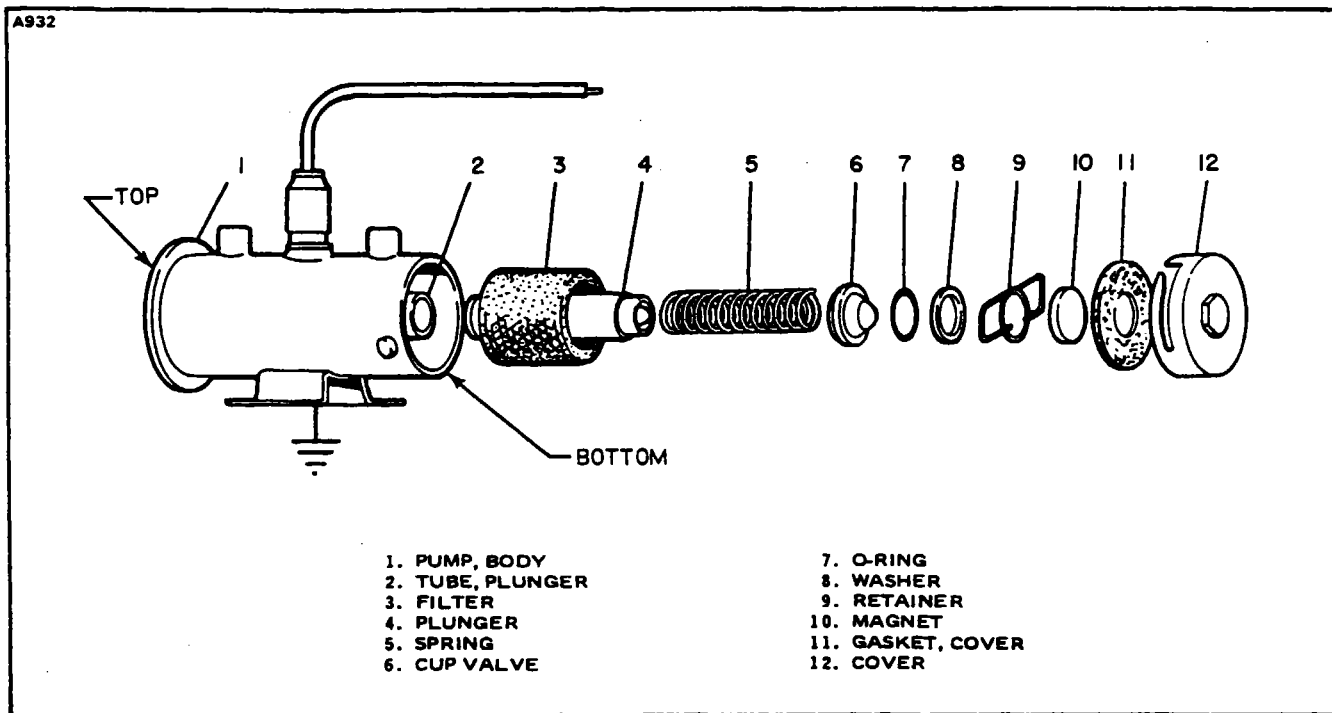

Figure 13-15. Heater Fuel Pump

13-46. DISASSEMBLY OF PUMP. (Refer to Figure 13-15.)

- a. Remove the safety wire that secures the bottom cover (12) to the pump.
- b. Using a 5/8 inch wrench, release the bottom cover (12) from the bayonet fittings. Twist the cover by hand to remove it from the pump body (1).
- c. Remove the filter (3), magnet (10) and cover gasket (11).
- d. Remove the retainer spring (9) from the plunger tube (2) using thin nose pliers to spread and remove ends of retainer from tube.
- e. Remove washers (8), O-ring seal (7), cup valve (6), plunger spring (5) and plunger (4) from the tube (2).

13-47. CLEANING OF PUMP.

- a. Wash all parts in cleaning solvent and blow out with air pressure.
- b. If plunger does not wash clean or if there are any rough spots, gently clean the surface with crocus cloth.
- c. Slosh the pump assembly in cleaning solvent and blow out with air pressure.
- d. Swab the inside of the tube with a cloth wrapped around a stick.

13-48. INSPECTION AND REPAIR OF PUMP.

- a. Disassemble the pump according to Paragraph 13-46.
- b. The filter usually comes off with the cover; it may stick inside the fuel pump. Carefully remove the filter and replace it, if distorted.
- c. Check cover gasket and replace if deteriorated.
- d. Check the O-ring seal and plunger spring and replace if worn.

13-49. ASSEMBLY OF PUMP. (Refer to Figure 13-15.)

- a. Insert the plunger (4) into the tube with the buffer spring end first. Check fit by slowly raising and lowering the plunger in the tube. It should move fully without any tendency to stick. If a click cannot be heard, the interrupter assembly is not functioning properly in which case the pump should be replaced.
- b. Install the plunger spring (5), cup valve (6), O-ring seal (7) and washer (8).
- c. Compress spring (5) and assembly retainer (9) with ends of retainer in side holes of tube (4).
- d. Place the cover gasket (11) and magnet (10) in the bottom cover (12) and assemble the filter (3) and cover assembly.
- e. Twist the cover by hand to hold in position on pump housing. Using a 5/8 inch wrench, securely tighten the bottom cover with the bayonet fittings on the pump body and install safety wire.

13-50. INSTALLATION OF HEATER FUEL PUMP.

- a. Position the fuel pump into the compartment and secure in place with bolts.
- b. Connect the regulator to the pump outlet and the fuel line to the pump inlet.
- c. Connect the electrical lead from the pump.
- d. Operate the heater to make sure the unit is functioning properly. (Refer to Paragraph 13-5, Heater System - Operational Test.)
- e. Replace all access covers removed to service the system.

13-51. DUCT SWITCH. (Refer to Figure 13-20 or 13-21.)

- a. Removal:
 1. Disconnect the electrical leads from the terminals on the exposed face of the switch and mark to facilitate installation.
 2. Remove the two attaching screws and washers from the duct switch bracket.
 3. Carefully lift out the switch and gasket (if gasket is used).
- b. Cleaning and Inspection:
 1. Brush off any dust or lint from the switch operating mechanism (exposed inside the duct) and wipe the external surfaces with a clean cloth.
- c. Installation:
 1. Insert the switch carefully with gasket (if used) into the ventilating duct opening and secure with the two attaching screws and washers.
 2. Connect the two electrical leads to their respective terminals on the face of the switch as marked during removal.
 3. Operate the heater with the duct switch set above ambient temperature to check operation. Refer to Paragraph 13-72, Step 1 for additional switch tests and setting instructions.

13-52. DELETED.

13-53. DISASSEMBLY (30,000 BTU HEATER). (Refer to Figure 13-18.)

- a. Remove the screw and slide the elbow adapter (23) off the combustion air inlet tube.
- b. Disconnect and remove electrical wiring and individual wires from the various components on the heater. If wires appear to be in good condition, it may be desirable to remove wire harness assembly intact. First, disconnect wires at terminal strip and components. The ventilating air blower housing must be removed so that the two motor wires quick-disconnect may be released.

NOTE

It is advisable to label all wires, prior to removal, to insure correct connections during reassembly. Cable straps and clips must be replaced if removed, as they cannot be re-used.

- c. Carefully disconnect the high voltage ignition lead at the spark plug. Handle the spring connector on the end of this lead with care to prevent fouling or damage.
- d. Remove the four screws, lock washers, and cable straps to free the ignition assembly (2) from the heater jacket and remove the ignition assembly. The vibrator may be removed by exerting a firm pull straightaway from the ignition assembly case after releasing the nut and screw.
- e. Remove the grommet (39) from the jacket (5) and remove the spark plug (32) with a 7/8 inch deep socket. Make sure the spark plug gasket is removed.
- f. Remove the two screws, lock washers and plain washers, and lift out the overheat (limit) switch (25) and spacer gaskets (27).
- g. Remove the two screws, lock washers and plain washers, and lift out the cycling switch (24).
- h. Remove the four screws and lock washers to release the terminal strip (35) and insulator (36) from the jacket (5).
- i. Disconnect the tube fitting (33) at the cover of the combustion air pressure switch (26). (Refer to Paragraph 13-39, a, Step 1 for precaution on tube bending.) Unscrew and remove the combustion air pressure switch (26) from the combustion air inlet tube.
- j. Remove vent air inlet adapter (16) from the blower housing by removing the three screws and lock washers.
- k. Loosen the four screws (20) and rotate the blower and motor housing (11) to disengage the notched end from the four screws in the end of the heater jacket. Disconnect the motor wiring quick-disconnect.
- l. Remove the upper fuel shroud box assembly (10) by removing the screws.
- m. Reach inside the inlet end of the jacket assembly (5) with a 3/4 inch open-end wrench and while holding the fuel-tube fitting at the jacket, use a 3/4 inch deep socket to remove the nut (38), washer and gasket (29).
- n. Remove the combustion head assembly (6) and the gasket (30) from the combustion tube assembly (7) by removing the screws and washers.
- o. Remove the two screws and lock washers; then carefully withdraw the nozzle holder and valve assembly from the combustion head assembly (6).
- p. Remove the screws, lock washers and remaining cable straps, if not previously removed, from the seam of the jacket assembly (5). Note positions of cable straps as they are removed. Spread the jacket (5) at the seam and remove it from the combustion tube assembly (7). This will free the rope gasket (31), which can be removed from the particular part to which it remains attached.
- q. Carefully unscrew and remove the spray nozzle (21) from the nozzle holder (8). Remove the gasket (28).

CAUTION

Handle the nozzle with care to avoid damage to the tip. The material around the orifice is very thin and any sharp blow on the face of the nozzle can distort the spray pattern and cause malignition or improper combustion.

- r. Remove the fuel solenoid assembly (22) by removing the nipple (37) and elbow (34).
- s. Loosen the nut and remove the screw, flat washer, and rubber grommet from blower housing (12).
- t. Remove the two screws, flat washers, and rubber grommets at the other two locations around the blower motor housing (12).
- u. Slide the ventilating air blower motor out of the blower housing (12) with the motor bracket assembly (19) and blower wheel (17) attached. Loosen the set screw in the blower wheel (17) and slide it off the end of the motor shaft. The flat washers and rubber washers will fall out when the bracket is removed. Then remove the motor bracket assembly (19). If these parts are in good condition, they need not be disassembled further.
- v. Remove the screw and lock washer to free the capacitor assembly (18) with attached leads.

13-54. DISASSEMBLY OF COMBUSTION AIR BLOWER ASSEMBLY (30,000 BTU). (Refer to Figure 13-20.)

- a. Remove the combustion air blower inlet adapter (2) by removing three screws, lock washers, cover plate and gasket.
- b. Remove the outlet adapter (5) by removing the two screws (6) and lock washers (7).
- c. Remove the inlet flange (8) by removing the three screws (9) and lock washers (10).
- d. Remove screws (12 and 16) and lock washers (13 and 17); then separate the back plate (20), with motor (25) attached, from the blower housing (15) and free the motor leads and capacitor (11) from the back plate (20).
- e. Loosen the set screw in the blower wheel (19) and slide it off the motor shaft.
- f. Remove the two hex nuts (21), lock washers (23) and flat washers (22), and slide the back plate (20) off the motor through bolts. The spacer (24) will drop out.
- g. Install new motor brushes as described in Paragraph 13-27, b. If the motor commutator is badly worn or if the motor is defective in any respect, it must be replaced.

13-55. CLEANING. (Refer to Figure 13-18.)

- a. Clean individual metal parts (except those parts containing switches and electrical wiring) and the combustion tube assembly by immersing them in dry-cleaning solvent, such as Stoddard solvent (Federal Specification P-D-680). A bristle brush should be used to assist the cleaning process if foreign accumulations are stubborn to remove.

CAUTION

Do not attempt to buff or scrape off any deposits on face of spray nozzle. The face of the nozzle is very susceptible to damage from mishandling. Carefully repeat cleaning process using only a bristle brush and repeated applications of solvent to loosen any stubborn deposits.

- b. Use compressed air or lintless cloth to dry the parts, unless sufficient time is available for them to air dry.
- c. Wipe electrical components with a clean, dry cloth. If foreign material is difficult to remove, moisten the cloth in carbon tetrachloride or electrical contact cleaner and clean all exterior surfaces thoroughly.

13-56. CLEANING AND INSPECTING THE COMBUSTION TUBE ASSEMBLY (30,000 BTU). (Refer to Figure 13-18.)

a. Slight scaling and discoloration of the combustion tube assembly (7) is a normal condition for units that have been in service up to 1000 airplane hours. The slight scaling condition will appear to be mottled and a small accumulation of blue-gray powder may be present on the surface in certain areas. This condition does not require replacement of the combustion tube assembly, unless severe overheating has produced soft spots in the metal.

NOTE

This assembly should be inspected prior to cleaning in order to prevent the removal of visible evidences of damage.

b. Look inside the exhaust outlet to determine if the combustion tube appears to be heavily scaled or mottled. Deformation is more difficult to detect visually but can usually be observed by looking straight through the combustion tube assembly and sighting along the outer surface of the inner combustion tube. An assembly that has been obviously deformed should be replaced. Slight deformation will not affect heater operation unless it is extensive and localized enough to reduce the flow of ventilating air through the heater more than 10 percent.

c. The combustion tube assembly may be cleaned by either of two methods:

1. One method is to soak the combustion tube assembly overnight in an Oakite M-S Stripper solution made by mixing one pound of Oakite salts with each gallon of water used. The solution should be maintained at a temperature of between 190°F and 210°F. After soaking overnight, rinse the combustion tube assembly thoroughly in water to remove all traces of the Oakite solution. In order to reach all areas of the combustion tube assembly, it is advisable to let it stand in the rinsing water for as long as 1/2 hour, while occasionally agitating it to circulate the water. All openings should be left open during this operation. Be sure to dry the combustion tube assembly thoroughly after cleaning.

2. A second method of cleaning is what is commonly known as hand "tumbling." Insert shot or other metallic particles through the exhaust outlet opening; then close all openings and shake the combustion tube assembly vigorously while rotating it and changing from end-to-end frequently. Be sure to pour out all of the particles and loosened material; then with all openings uncovered, direct a stream of compressed air into the combustion tube assembly from first one opening, then the other. Make sure all loose material is removed.

13-57. INSPECTION OF REMAINING COMPONENTS (30,000 BTU). (Refer to Figure 13-18.)

a. Discard all rubber parts such as grommets, gaskets, etc. These items should always be replaced at overhaul. Also discard the rope gasket (31).

b. Inspect all wires and wiring harnesses for damage to insulation, damaged terminals, chafed or cracked insulation and broken plastic bands. Individual wires can be replaced by making up new wires from No. 16 AWG stock and cut to correct length. It is advisable to use an acceptable crimping tool for installing terminals, rather than solder for all heater wiring connections. If wiring harness damage is visible, the entire harness assembly should be replaced. If only one or more wires are damaged, cut the cable ties, make up new wires, install them in the harnesses and restore all cable ties and clamps. If heater controls were operating properly at the time of removal, reinstall them.

PIPER SENECA II SERVICE MANUAL

- c. Inspect all hard parts consisting of bolts, screws, nuts, washers and lock washers. Replace damaged parts.
- d. The combustion air pressure switch (26) must respond to delicate pressure changes and should always be checked and/or replaced at overhaul. (Refer to Paragraph 13-63, c and Figure 13-14.)
- e. Replace the vibrator in the ignition unit at each overhaul.
- f. Inspect the ignition assembly (2, Figure 13-18) for dented case, loose or damaged primary terminal insulator and broken or obviously damaged high voltage lead. Give particular attention to the condition of the spring connector at the end of the lead. If the spring is burned off, visibly eroded, or carbon tracked, the ignition assembly should be replaced.

NOTE

Do not attempt a field repair of the ignition unit, as it is a sealed assembly.

- g. Inspect the terminal strip (35) for distortion and cracks, and replace it if either condition exists.
- h. Inspect radio-noise filters for short circuits by checking from either terminal to ground with an ohmmeter. An open-circuit reading should be obtained.
- i. Inspect the spray nozzle (21) with a magnifying glass for any obstructions in the nozzle orifice and any sign of damage to the slight conical protrusion at the nozzle tip. Use compressed air to remove obstructions and re-examine the orifice to make sure it is open. Exercise care when handling the nozzle to avoid pressing or rapping on the tip face. Do not buff or scrape off deposits on the tip face. After cleaning, it is advisable to store the nozzle in a polyethylene bag until ready for reassembly.
- j. Replace the nozzle at overhaul.

NOTE

The nozzle (21) can be spray tested by installing it in the holder and connecting the fuel tube to a 7 psi fuel pressure source. Connect the solenoid leads to a 12-volt battery to open the solenoid valve. The conical angle spray pattern should be even and dispersed the same in all directions. Exercise caution to keep atomized fuel away from fire.

- k. Inspect the nozzle holder and solenoid valve assembly for damaged threads at the fuel-tube fitting and for crimped or cracked fuel line or distorted housing. The only part in this assembly that can be replaced is the solenoid winding. Check the solenoid for continuity by connecting across each wire lead with an ohmmeter. A reading of between 18 and 22 ohms should be obtained at room temperature. If not within these limits, or if the solenoid winding shows any form of physical damage or overheating, it should be replaced.
- l. Remove the brushes, one at a time, from the ventilating air blower motor (13) by removing the brush cap and carefully withdrawing the brush from its guide. Remove foreign material from the brush guide and commutator with a stream of filtered compressed air. Check for brush wear (refer to Paragraph 13-27). Inspect the commutator for grooved brush track, pitting or burning. The commutator surface should be smooth and medium brown in color. Replace the motor if the commutator or other parts show damage.
- m. Inspect the combustion air blower motor as described in the preceding step.
- n. Inspect the blower wheel for broken or bent vanes and replace it for either condition.

13-58. DISASSEMBLY (45,000 BTU HEATER). (Refer to Figure 13-19.)

- a. Remove the screw and slide the elbow adapter (23) off the combustion air inlet tube.
- b. Disconnect and remove electrical wiring and individual wires from the various components on the heater. If wires appear to be in good condition, it may be desirable to remove wire harness assembly intact. First disconnect wires at terminal strip and components.

NOTE

It is advisable to label all wires, prior to removal, to insure correct connections during reassembly. Cable straps and clips must be replaced if removed, as they cannot be reused.

- c. Carefully disconnect the high voltage ignition lead at the spark plug. Handle the spring connector on the end of this lead with care to prevent fouling or damage.
- d. Remove the four screws and cable straps to free the ignition assembly (2) from the heater jacket and remove the ignition assembly. The vibrator may be removed by releasing the clamp and exerting a firm pull straightaway from the ignition assembly case.
- e. Remove the grommet (39) from the jacket (5) and remove the spark plug (32) with a 7/8 inch deep socket. Make sure the spark plug gasket is removed.
- f. Remove the two screws and lift out the overheat (limit) switch (25) and spacer gaskets (27).
- g. Remove the two screws and lift out the cycling switch (24).
- h. Remove the four screws to release the terminal strip (35) and insulator (36) from the jacket (5).
- i. Disconnect the tube fitting (33) at the cover of the combustion air pressure switch (26). Refer to Paragraph 13-39, a, Step 1 for precaution on tube bending. Unscrew and remove the combustion air pressure switch (26) from the combustion air inlet tube.
- j. Remove vent air inlet adapter (16) from the blower housing by removing the three screws.
- k. Loosen the four screws (20) and rotate the blower and motor housing (11) to disengage the notched end from the four screws in the end of the heater jacket. Disconnect the motor wiring quick-disconnect.
- l. Remove the upper fuel shroud box cover (10) by removing the screws.
- m. Remove the grommet from the fuel shroud (9) and carefully pull the fuel solenoid wires through the hole in the shroud.
- n. With an open end wrench, remove the fuel solenoid assembly being careful not to damage the wires on the solenoid.
- o. Reach inside the inlet end of the jacket assembly (5) with a 3/4 inch open-end wrench, and while holding the fuel-tube fitting at the jacket, use a 3/4 inch deep socket to remove the elbow (34), nut (38), washer (41), gasket (29) and fuel shroud (9).
- p. Remove the two screws and carefully withdraw the nozzle holder (8) from the combustion head assembly (6); remove gasket (28).
- q. Remove the six screws and withdraw the combustion head assembly (6) from the combustion tube assembly (7). Remove gasket (30).
- r. Remove the screws and remaining cable straps, if not previously removed, from the seam of the jacket assembly (5). Note the position of the cable straps as they are removed. Spread the jacket at the seam and remove it from the combustion tube assembly (7). This will free the asbestos gasket (31) which can be removed from the particular part to which it remains attached.
- s. Carefully unscrew and remove the spray nozzle (21) from the nozzle holder (8). Remove the gasket (28).

CAUTION

Handle the nozzle with care to avoid damage to the tip. The material around the orifice is very thin and any sharp blow on the face of the nozzle can distort the spray pattern and cause malignition or improper combustion.

- t. Remove the three screws and rubber grommets from the blower housing (12).
- u. Slide the ventilating air blower motor out of the blower housing with the motor bracket assembly (19) and blower wheel (17) attached. Loosen the set screw in the blower wheel and slide it off the end of the motor shaft. Then remove the motor bracket assembly (19), fasteners (43) and ground bracket (44).
- v. Remove the screw and lock washer to free the capacitor assembly (18) with attached leads.

13-59. DISASSEMBLY OF COMBUSTION AIR BLOWER ASSEMBLY (45,000 BTU). (Refer to Figure 13-21.)

- a. Remove the combustion air blower inlet adapter (2) by removing the screw (18).
- b. Remove screws (18); then separate the outer housing (3) from the inner housing (8) and free the motor leads and capacitor (10) from the inner housing.
- c. Loosen the set screw (6) in the blower wheel (7) and slide it off the motor shaft.
- d. Remove the two hex nuts (17), lock washers (00) and flat washers (16) and slide the inner housing (8) off the motor through bolts. The spacer (15) will drop out.
- e. Install new motor brushes as described in Paragraph 13-27, b. If the motor commutator is badly worn or if the motor is defective in any respect, it must be replaced.

13-60. CLEANING. (Refer to Figure 13-19.)

- a. Clean individual metal parts (except those parts containing switches and electrical wiring) and the combustion tube assembly by immersing them in dry-cleaning solvent, such as Stoddard solvent (Federal Specification P-D-680). A bristle brush should be used to assist the cleaning process if foreign accumulations are stubborn to remove.

CAUTION

Do not attempt to buff or scrape off any deposits on face of spray nozzle. The face of the nozzle is very susceptible to damage from mishandling. Carefully repeat cleaning process using only a bristle brush and repeated applications of solvent to loosen any stubborn deposits.

- b. Use compressed air or lintless cloth to dry the parts, unless sufficient time is available for them to air dry.
- c. Wipe electrical components with a clean, dry cloth. If foreign material is difficult to remove, moisten the cloth in carbon tetrachloride or electrical contact cleaner and clean all exterior surfaces thoroughly.

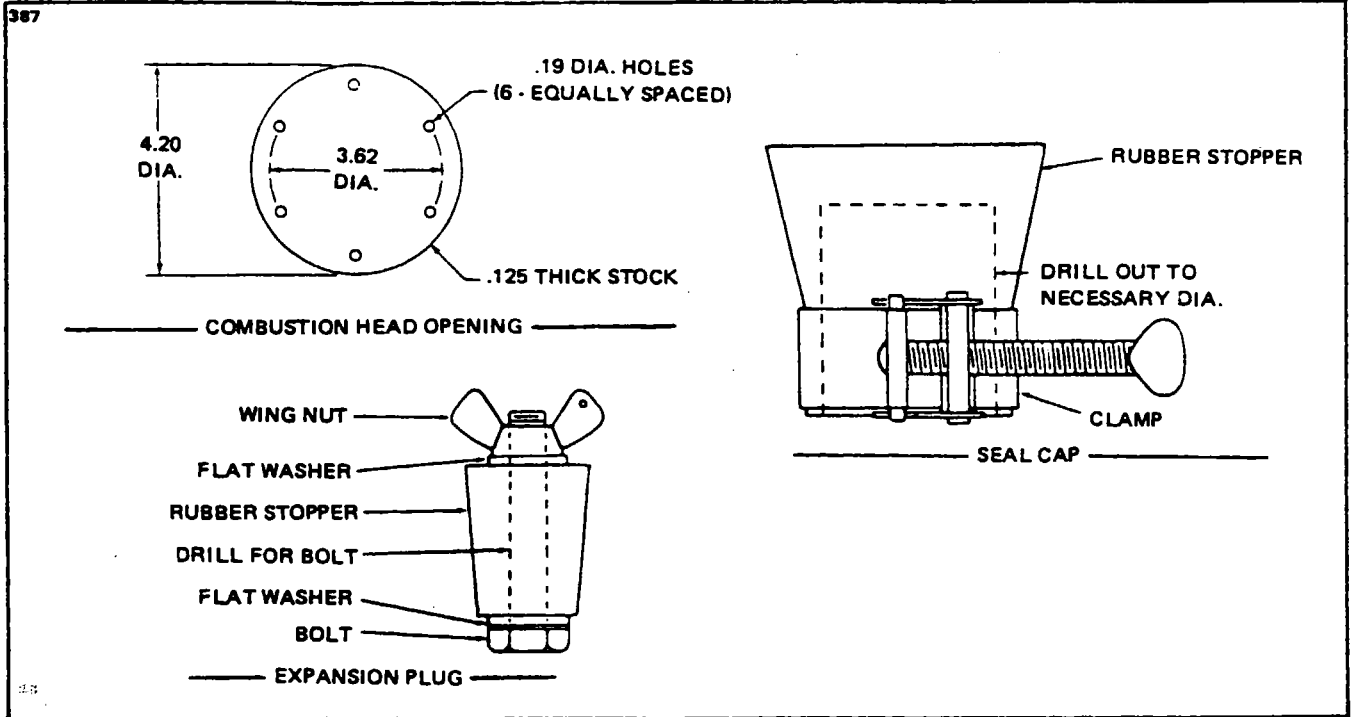

Figure 13-16. Suggested Design for Seal Plates, Plugs, and Caps for Combustion Tube Leakage Test

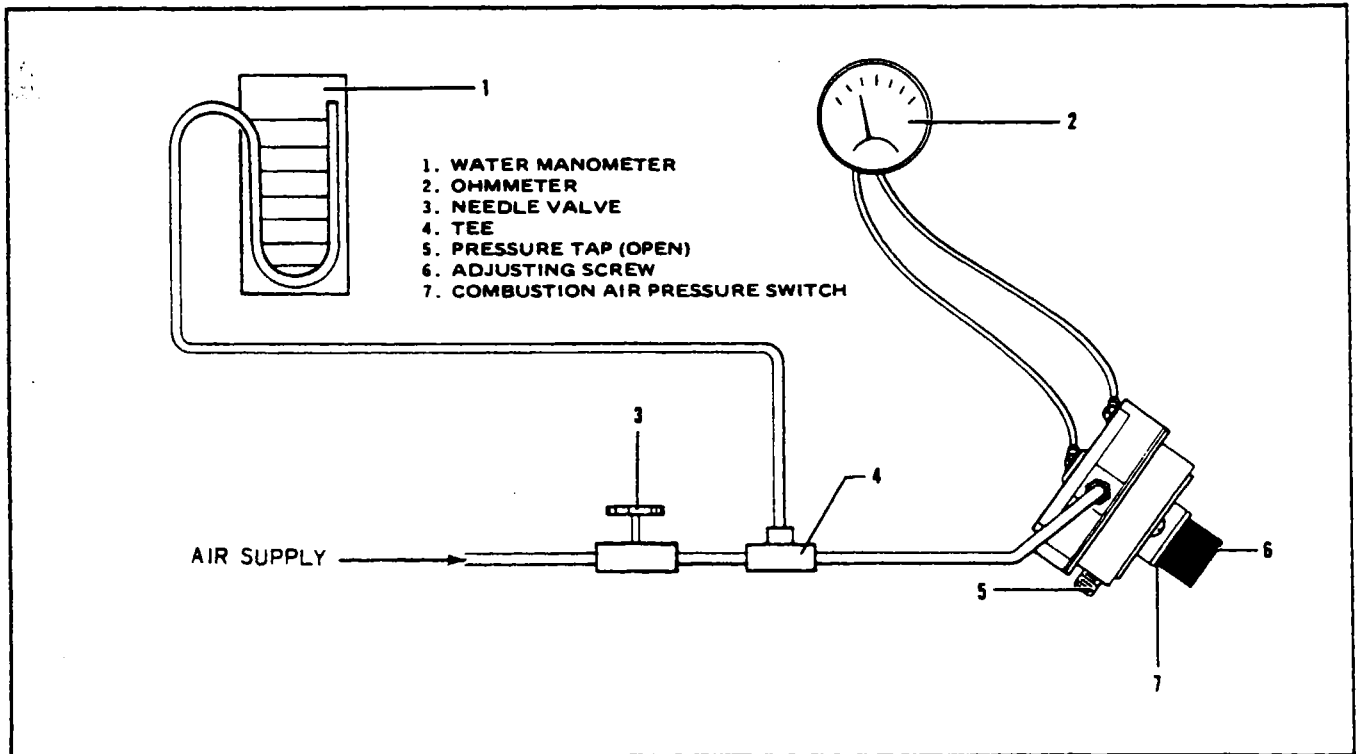

Figure 13-17. Test Setup for Combustion Air Pressure Switch

PIPER SENECA II SERVICE MANUAL

13-61. CLEANING AND INSPECTING THE COMBUSTION TUBE ASSEMBLY (45,000 BTU). (Refer to Figure 13-19.)

a. Slight scaling and discoloration of the combustion tube assembly (7) is a normal condition for units that have been in service up to 1000 airplane hours. The slight scaling condition will appear to be mottled and a small accumulation of blue-gray powder may be present on the surface in certain areas. This condition does not require replacement of the combustion tube assembly unless severe overheating has produced soft spots in the metal.

NOTE

This assembly should be inspected prior to cleaning in order to prevent the removal of visible evidences of damage.

b. Look inside the exhaust outlet to determine if the combustion tube appears to be heavily scaled or mottled. Deformation is more difficult to detect visually but can usually be observed by looking straight through the combustion tube assembly and sighting along the outer surface of the inner combustion tube. An assembly that has been obviously deformed should be replaced. Slight deformation will not affect heater operation unless it is extensive and localized enough to reduce the flow of ventilating air through the heater more than 10 percent.

c. The combustion tube assembly may be cleaned by either of two methods:

1. One method is to soak the combustion tube assembly overnight in an Oakite M-S Stripper solution made by mixing one pound of Oakite salts with each gallon of water used. The solution should be maintained at a temperature of between 190°F and 210°F. After soaking overnight, rinse the combustion tube assembly thoroughly in water to remove all traces of the Oakite solution. In order to reach all areas of the combustion tube assembly, it is advisable to let it stand in the rinsing water for as long as 1/2 hour while occasionally agitating it to circulate the water. All openings should be left open during this operation. Be sure to dry the combustion tube assembly thoroughly after cleaning.

2. A second method of cleaning is what is commonly known as hand "tumbling." Insert shot or other metallic particles through the exhaust outlet opening; then close all openings and shake the combustion tube assembly vigorously while rotating it and changing from end-to-end frequently. Be sure to pour out all of the particles and loosened material; then with all openings uncovered, direct a stream of compressed air into the combustion tube assembly from first one opening, then the other. Make sure all loose material is removed.

13-62. INSPECTION OF REMAINING COMPONENTS (45,000 BTU). (Refer to Figure 13-19.)

a. Discard all rubber parts such as grommets, gaskets, etc. These items should always be replaced at overhaul. Also discard the asbestos gasket (31).

b. Inspect all wires and wiring harnesses for damage to insulation, damaged terminals, chafed or cracked insulation and broken plastic bands. Individual wires can be replaced by making up new wires from No. 16 AWG stock and cut to correct length. It is advisable to use an acceptable crimping tool for installing terminals rather than solder for all heater wiring connections. If wiring harness damage is visible, the entire harness assembly should be replaced. If only one or more wires are damaged, cut the cable ties, make up new wires, install them in the harnesses and restore all cable ties and clamps. If heater controls were operating properly at the time of removal, reinstall them.

c. Inspect all hard parts consisting of bolts, screws, nuts, washers and lock washers. Replace damaged parts.

d. The combustion air pressure switch (26) must respond to delicate pressure changes and should always be checked and/or replaced at overhaul. (Refer to Paragraph 13-63, c and Figure 13-17.)

- e. Replace the vibrator in the ignition unit at each overhaul.
- f. Inspect the ignition assembly (2, Figure 13-19) for dented case, loose or damaged primary terminal insulator and broken or obviously damaged high voltage lead. Give particular attention to the condition of the spring connector at the end of the lead. If the spring is burned off, visibly eroded or carbon tracked, the ignition assembly should be replaced.

NOTE

Do not attempt a field repair of the ignition unit, as it is a sealed assembly.

- g. Inspect the terminal strip (35) for distortion and cracks and replace it if either condition exists.
- h. Inspect radio-noise filters for short circuits by checking from either terminal to ground with an ohmmeter. An open circuit reading should be obtained.
- i. Inspect the spray nozzle (21) with a magnifying glass for any obstructions in the nozzle orifice and any sign of damage to the slight conical protrusion at the nozzle tip. Use compressed air to remove obstructions and re-examine the orifice to make sure it is open. Exercise care when handling the nozzle to avoid pressing or rapping on the tip face. Do not buff or scrape off deposits on the tip face. After cleaning, it is advisable to store the nozzle in a polyethylene bag until ready for reassembly.
- j. Replace the nozzle at overhaul.

NOTE

The nozzle (21) can be spray tested by installing it in the holder and connecting the fuel tube to a 7 psi fuel pressure source. The conical angle spray pattern should be even and dispersed the same in all directions. Exercise caution to keep atomized fuel away from fire.

- k. Inspect the nozzle holder assembly for damaged threads at the fuel-tube fitting and for crimped or cracked fuel line or distorted housing. Check the solenoid for continuity by connecting across each wire lead with an ohmmeter. A reading of between 15 and 40 ohms should be obtained at room temperature. If not within these limits, the solenoid should be replaced.
- l. Remove the brushes, one at a time, from the ventilating air blower motor (13) by removing the brush cap and carefully withdrawing the brush from its guide. Remove foreign material from the brush guide and commutator with a stream of filtered compressed air. Check for brush wear (refer to Paragraph 13-25). Inspect the commutator for grooved brush track, pitting or burning. The commutator surface should be smooth and medium brown in color. Replace the motor if the commutator or other parts show damage.
- m. Inspect the combustion air blower motor as described in the preceding step.
- n. Inspect the blower wheel for broken or bent vanes and replace it for either condition.

13-63. TESTING. The following tests should be performed as outlined in the succeeding paragraphs:

- a. Check ventilating air and combustion air motors for correct RPM and current draw:
 - 1. Connect motor to 12-volt DC power supply. Rotation should be counterclockwise when viewed from the shaft end.
 - 2. Both motors should rotate at approximately 7500 RPM at rated voltage. Current draw is approximately five amperes.
 - 3. If current draw is excessive or if speed is too low, replace the brushes. Recheck both current draw and RPM after brushes are properly run in. (Refer to Paragraph 13-27, b.)
 - 4. If after replacing brushes operation is still unsatisfactory, replace the motor.

PIPER SENECA II SERVICE MANUAL

NOTE

The motor checks described above should be made without the blower housing attached, for both the ventilating air and combustion air motors.

b. Test the combustion tube assembly (7) for leaks as follows:

1. Fashion a sealing plate from approximately 1/8 inch thick flat stock to seal the combustion head opening in the combustion tube assembly. (Refer to Figure 13-16.) Use a rubber gasket under the plate and attach the plate with six screws.

2. Make up seals for all remaining openings, except the one used to connect the air pressure source. (Refer to Figure 13-16.) Use rubber stoppers as shown. The combustion air inlet tube can be sealed best with a drilled stopper and clamp. Other openings should be sealed with expansion plugs. The seal used in the exhaust tube should be formed so that it will not deform the air pressure switch tube which protrudes into the exhaust.

3. Install plugs and caps in all openings except the one to which the combustion air pressure switch is attached. (Any opening can be used to connect the air pressure source; however, the combustion air pressure switch opening is usually the most convenient. The drain opening would normally be considered a second choice.)

4. Connect a regulated air supply to the opening that has not been plugged and apply a pressure of between three and five psi to the combustion tube assembly.

5. Submerge the combustion tube assembly in water for several minutes while watching for bubbles which would indicate leaks. No air leakage is permitted from the combustion tube assembly. No weld or braze repairs are permitted on a combustion tube assembly.

c. Test the combustion air pressure switch as follows:

1. Connect an adjustable air pressure line that can be controlled in a range of zero to 5.0 psi (maximum) of water to the switch opening with a water manometer and needle valve in the line ahead of switch. Switch must be tested in 45 degree position as shown in Figure 13-17.

2. Connect an ohmmeter across the switch terminals to determine the exact instant of switch closing.

3. Apply air pressure allowing it to build up very slowly from zero. The switch contacts should close at 0.5 ± 0.1 inches of water which will be indicated on the manometer.

NOTE

The switch cover has a differential pressure tap and this opening must be left open to atmosphere during test.

4. Make several trials to insure switch reliability. Be sure to increase and decrease the air pressure slowly in order to produce accurate indications.

5. If an adjustment is required, rotate the adjusting screw clockwise to increase settings and counterclockwise to decrease settings.

d. Test the fuel line and fuel line shroud tube for leaks as follows:

1. Using filtered compressed air, apply 20 psi to the shroud drain port located on the surface near the threaded nozzle cavity.

2. Immerse the fuel feed and nozzle holder assembly in clean water with the fuel inlet and nozzle cavity left open.

PIPER SENECA II SERVICE MANUAL

A309

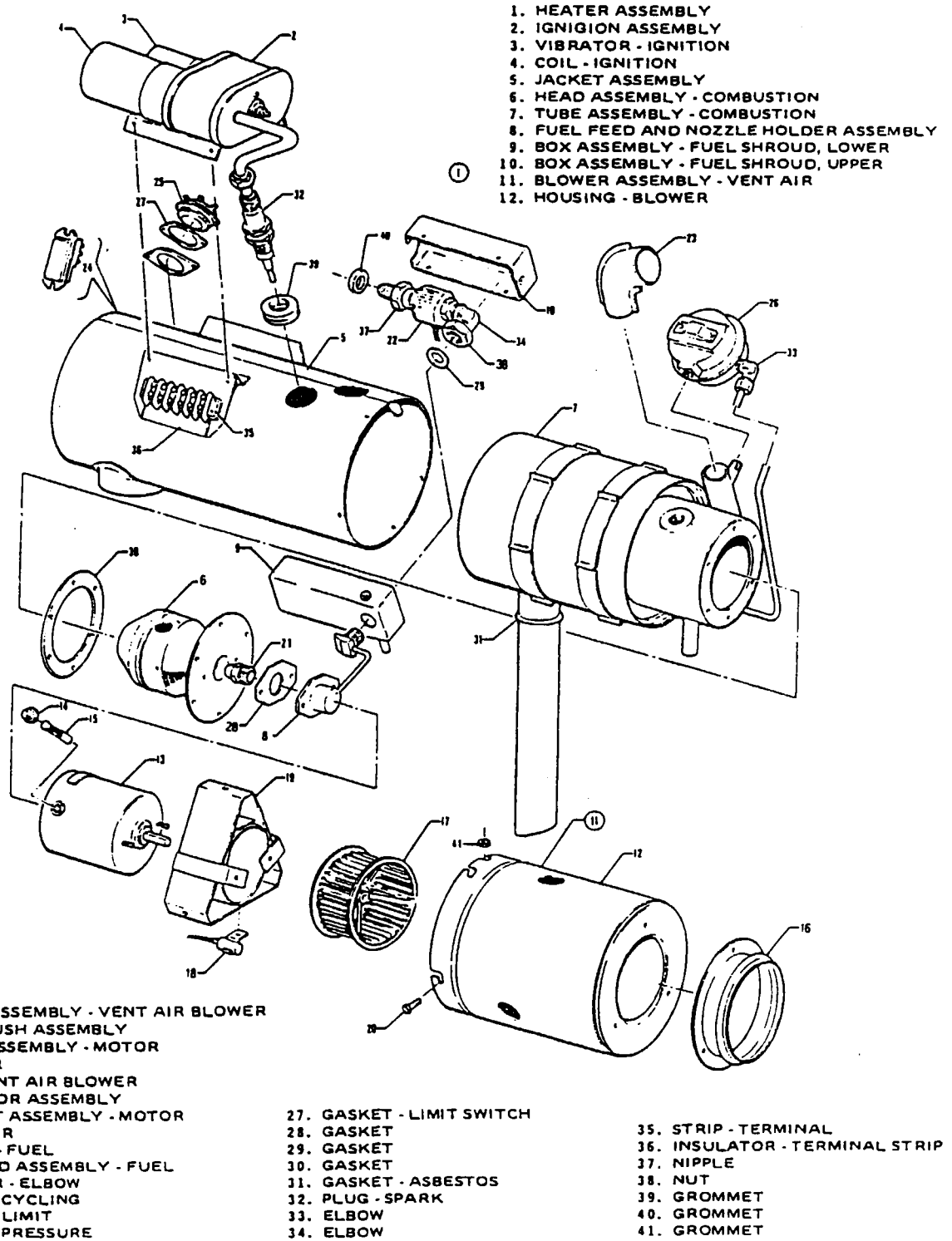

Figure 13-18. Exploded View of Heater Assembly (30,000 BTU)

Reissued: 10/11/79

HEATING AND VENTILATING SYSTEM

2K21

PIPER SENECA II SERVICE MANUAL

- | | | |
|---|--|--|
| <ol style="list-style-type: none"> 1. HEATER ASSEMBLY 2. IGNITION ASSEMBLY 3. VIBRATOR - IGNITION 4. COIL - IGNITION 5. JACKET ASSEMBLY 6. HEAD ASSEMBLY - COMBUSTION 7. TUBE ASSEMBLY - COMBUSTION 8. FUEL FEED AND NOZZLE HOLDER ASSEMBLY 9. BOX ASSEMBLY - FUEL SHROUD, LOWER 10. BOX ASSEMBLY - FUEL SHROUD, UPPER 11. BLOWER ASSEMBLY - VENT AIR 12. HOUSING - BLOWER 13. MOTOR ASSEMBLY - VENT AIR BLOWER 14. CAP - BRUSH ASSEMBLY 15. BRUSH ASSEMBLY - MOTOR 16. ADAPTER | <ol style="list-style-type: none"> 17. FAN - VENT AIR BLOWER 18. CAPACITOR ASSEMBLY 19. BRACKET ASSEMBLY - MOTOR 20. FASTENER 21. NOZZLE - FUEL 22. SOLENOID ASSEMBLY - FUEL 23. ADAPTER - ELBOW 24. SWITCH - CYCLING 25. SWITCH - LIMIT 26. SWITCH - PRESSURE 27. GASKET - LIMIT SWITCH 28. GASKET 29. GASKET 30. GASKET 31. GASKET - ASBESTOS 32. PLUG - SPARK | <ol style="list-style-type: none"> 33. ELBOW 34. ELBOW 35. STRIP - TERMINAL 36. INSULATOR - TERMINAL STRIP 37. NIPPLE 38. NUT 39. GROMMET 40. GROMMET 41. WASHER 42. SCREWS 43. FASTENERS 44. BRACKET - GROUND 45. GROMMET 46. GROMMET 47. GROMMET 48. OPTIONAL HEATER HOURMETER |
|---|--|--|

3088

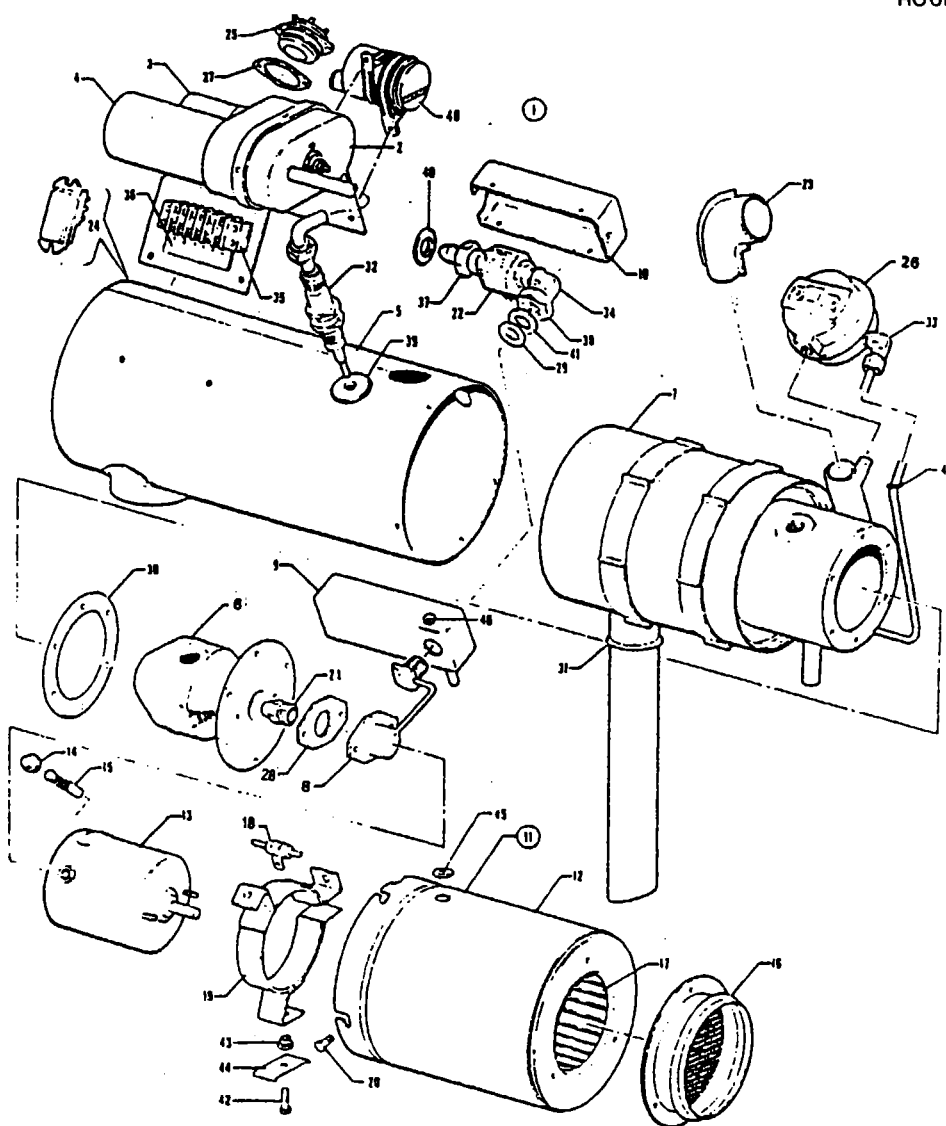

Figure 13-19. Exploded View of Heater Assembly (45,000 BTU)

3. Observe for bubbles which would indicate leakage. If bubbles appear at either fuel fitting, there is a leak in the fuel tube. If bubbles appear externally on the shroud tube or at either end of the shroud tube juncture, the shroud tube is leaking.

4. In either of the above cases, the complete fuel feed and nozzle holder assembly must be replaced.

e. Spray test the nozzle (21, Figure 13-18 or 13-19) as follows:

1. Install the nozzle in the fuel feed and nozzle holder assembly and connect the fuel tube to the fuel solenoid. Connect the solenoid to a 7 psi fuel pressure source.

2. Connect the solenoid leads to a 12-volt battery. Connect a switch in the line to open and close the solenoid when desired.

3. With the switch closed (solenoid valve energized) and the fuel line connected, observe the fuel spray pattern. It should be conical in shape with even dispersion in all directions.

WARNING

Be sure to keep the atomized spray away from fire.

4. Energize and de-energize the solenoid several times. The spray should shut off permanently each time the solenoid is de-energized. There should be no sign of dribbling at the nozzle tip in excess of one or two drops.

5. If the spray pattern is distorted, check for an obstruction and clean the nozzle as described in Paragraph 13-57 or 13-62, i. If this fails to provide a normal spray pattern, replace the nozzle.

6. If the nozzle continues to dribble, the solenoid valve is not closing properly and the solenoid valve must be replaced.

13-64. REPAIR OF COMBUSTION TUBE ASSEMBLY. No weld or braze repairs of the combustion tube assembly are authorized.

PIPER SENECA II SERVICE MANUAL

13-65. REASSEMBLY (30,000 BTU). (Refer to Figure 13-18.)

- a. If removed during disassembly, secure the nipple (37) and elbow (34) to the fuel solenoid (22).
- b. Insert the ventilating air motor (13) into the motor bracket assembly (19); slide the blower wheel (17) on the end of motor shaft and rotate it until the set screw is aligned with the flat side of the motor shaft. Tighten the set screw just tight enough to hold it at this time.
- c. Attach the capacitor and leads assembly (18) to the motor bracket (19) with the screw and lock washer. Make sure a good electrical ground connection is made at this point.
- d. Insert this assembly into the blower housing (12) and position it so the long screw is in alignment with the gap on the inner ring of the motor bracket assembly (19). This is the screw used to secure and align the motor in the bracket.
- e. Slide the flat washer and rubber washer into position between the legs of the motor bracket (19) and blower housing (12).
- f. Make sure all wires are routed and grommets as they were prior to disassembly and install the two screws, flat washers, and new grommets at the two lower edges securing the motor bracket assembly (19). Then install the grommet, flat washer, nut, and screw in the remaining (upper) corner of the motor bracket assembly (19).
- g. Center the motor bracket (19) in the housing and tighten the screw to secure it. The motor (13) should be positioned in the bracket (19) to locate the blower wheel (17) properly in the blower housing (12). The blower wheel should be positioned so it will rotate freely and just clear the contoured spill plate in the blower housing. Tighten the Allen-head set screws and spin the blower wheel by hand for a clearance check. Then apply appropriate voltage to run the motor as a final clearance check.
- h. Attach the inlet adapter (16) to the end of blower housing (12) with three screws and lock washers.
- i. Place a new rope gasket (31) in position on the exhaust outlet; spring the jacket assembly (5) open at the seam and insert the combustion tube assembly (7) carefully into the jacket. Exercise care to clear the pressure switch tube in the exhaust outlet and see that the rope gasket (31) is properly located. Close the gap on the jacket assembly and install screws and lock washers to secure it at the seam. (Two leads ground under these screws. See notations made during disassembly.) Make sure the tongue and channel at the seam are in good condition and a tight fit is effected.
- j. Install cable straps at locations noted during disassembly.
- k. Remove the spray nozzle (21) from the polyethylene bag. Screw the nozzle into nozzle holder and tighten to 75-100 inch-pounds. It is very important to torque the nozzle to this value as incorrect tightening could cause improper heater operation and "drool."

CAUTION

The spray nozzle has a slight protrusion on the nozzle face. If this area has been struck by any object which would make a dent or destroy the original contour, the nozzle must be replaced. It cannot be disassembled for cleaning.

- l. Install the gasket (30) and combustion head (6) in the combustion tube (7) and secure with the screws and washers.
- m. Insert the fitting on end of nozzle fuel tube through the opening in jacket (5) and attach the nozzle holder to the combustion head assembly (6) with the two screws and lock washers. It may be necessary to place a slight bend in the shrouded fuel tube to permit alignment of screw holes. Be sure to use a new gasket (28).
- n. Using a new spark plug gasket, install the spark plug (32) and tighten to a torque of 28 foot-pounds. Install the grommet (39) in the jacket around the spark plug.

- o. Install the ignition assembly (2) on the jacket assembly (5) with the four screws and lock washers. Connect the high voltage lead to the spark plug and tighten it to 20 foot-pounds.
- p. Attach the overheat limit switch (25) and spacer gaskets (27) to the jacket assembly (5) with the two screws, lock washers and flat washers. Tighten the screws securely.
- q. Attach the cycling switch (24) to the jacket assembly (5) with the two screws, lock washers and flat washers.
- r. Place the terminal strip insulation (36) in position on the jacket (5), followed by the terminal strip (35). Secure both parts by installing the two screws and lock washers. The two screws are located at two diagonal corners of the terminal strip.
- s. Center the fuel fitting in jacket opening. Position the fuel fitting shroud gasket (29) and washer; then install the nut (38) finger tight. Insert a 3/4 inch open-end wrench inside the jacket and hold the fuel-tube fitting while tightening the nut (38) with a 3/4 inch deep socket. Install the fuel solenoid elbow (34).
- t. Rotate the combustion air switch (26) onto the threaded fitting on the combustion air tube and tighten it firmly.
- u. Connect the tube to the elbow fitting (33) on the combustion air pressure switch (26).
- v. Install the wiring harness and connect all wire leads to their respective terminals. (Refer to the wiring diagram, Figure 13-7.) Place the grommet (41, Figure 13-18) in position in the jacket (5); locate the ventilating air blower (11) at the end of the jacket. Thread the quick-disconnect on the wiring harness through the grommet and connect it to the mating connector on the motor lead.
- w. Place the blower housing in position on the jacket assembly (5) and secure it by installing the four screws (20), if removed at disassembly. This operation is easier if the screws (20) are started into their threads and the blower housing rotated into place, allowing the screws to enter the notched openings in edge of blower housing. Tighten all screws securely.
- x. Install the elbow adapter (23) with the screw.
- y. Install the upper fuel shroud box (10) with the screws. Ascertain that the grommet (40) is installed.

13-66. REASSEMBLY OF COMBUSTION AIR BLOWER ASSEMBLY (30,000 BTU). (Refer to Figure 13-20.)

- a. Place the spacer (24) over the end of the motor shaft and attach the motor assembly (25) to the back plate (20) with the two self-locking nuts (21), flat washers (22) and lock washers (23).
- b. Slide the blower wheel (19) on the motor shaft and tighten the set screw lightly against the flat portion of the motor shaft.
- c. Place the blower housing (15) in position on the back plate (20) and install screws (16) and lock washers (17).
- d. Attach the radio-noise filter (11) at the point shown with the screw (12) and lock washer (13). The motor ground lead terminal (28) can be grounded to the motor support bracket (3).
- e. Attach the inlet flange (8) and blower inlet adapter (2) to blower housing (15) with three screws (9) and lock washers (10).
- f. Loosen the Allen-head set screw in the blower wheel (19) and shift the wheel on the motor shaft until it is near the inlet in the blower housing. Tighten the set screw securely. The blower wheel should just clear the inlet flange when rotated at full RPM. Spin the blower wheel by hand for clearance check; then apply proper voltage to run motor and recheck for proper clearance.
- g. Slide the blower outlet adapter (5) on the blower housing outlet (15) and install the two screws (6) and lock washers (7).

13-67. REASSEMBLY (45,000 BTU). (Refer to Figure 13-19.)

- a. If removed during disassembly, secure the nipple (37) and elbow (34) to the fuel solenoid (22).
- b. Insert the ventilating air motor (13) into the motor bracket assembly (19); slide the blower wheel (17) on the end of the motor shaft and rotate it until the set screw is aligned with the flat side of the motor shaft. Tighten the set screw just tight enough to hold it at this time.
- c. Attach the capacitor and leads assembly (18) to the motor bracket (19) with screw and lock washer. Make sure a good electrical ground connection is made at this point. Install ground bracket (44) and three new fasteners (43).
- d. Insert this assembly into the blower housing (12).
- e. Make sure all wires are routed and grommets as they were prior to disassembly and then secure the assembly in the housing with three screws (45).
- f. The motor (13) should be positioned in the bracket (19) to locate the blower wheel (17) properly in the blower housing (12). The blower wheel should be positioned so it will rotate freely and just clear the contoured spill plate in the blower housing. Tighten the Allen-head set screw and spin the blower wheel by hand for a clearance check. Then apply the appropriate voltage to run the motor as a final clearance check.
- g. Attach the inlet adapter (16) to the end of the blower housing (12) with three screws and lock washers.
- h. Place a new asbestos gasket (31) in position on the exhaust outlet; spring the jacket assembly (5) open at the seam and insert the combustion tube assembly (7) carefully into the jacket. Exercise care to clear the pressure switch tube in the exhaust outlet and see that the asbestos gasket (31) is properly located. Close the gap on the jacket assembly and install screws to secure it at the seam. (Solenoid lead wire is grounded under one of these screws. See notations made during disassembly.) Make sure the seam is in good condition and a tight fit is effected.
- i. Install cable straps at locations noted during disassembly.
- j. Remove the spray nozzle (21) from the polyethylene bag. Screw the nozzle into the nozzle holder and tighten to 75-100 inch-pounds. It is very important to torque the nozzle to this value as incorrect tightening could cause improper heater operation and nozzle "drool."

CAUTION

The spray nozzle has a slight protrusion on the nozzle face. If this area has been struck by any object which would make a dent or destroy the original contour, the nozzle must be replaced.

- k. Install a new gasket (30) and the combustion head (6) in the combustion tube (7) and secure with the six screws.
- l. Insert the fitting on end of nozzle fuel tube through the opening in jacket (5) and attach the nozzle holder to the combustion head assembly (6) with the two screws. It may be necessary to place a slight bend in the shrouded fuel tube to permit alignment of screw holes. Be sure to use a new gasket (28).
- m. Using a new spark plug gasket, install the spark plug (32) and tighten to a torque of 28 foot-pounds. Install the grommet (39) in the jacket around the spark plug.
- n. Install the ignition assembly (2) on the jacket assembly (5) with the four screws. Connect the high voltage lead to the spark plug and tighten it to 20 foot-pounds.
- o. Attach the overheat limit switch (25) and two spacer gaskets (27) to the jacket assembly (5) with the two screws. Tighten the screws securely.
- p. Attach the cycling switch (24) to the jacket assembly (5) with the two screws.
- q. Place the terminal strip insulation (36) in position on the jacket (5), followed by the terminal strip (35). Secure both parts by installing the two screws.

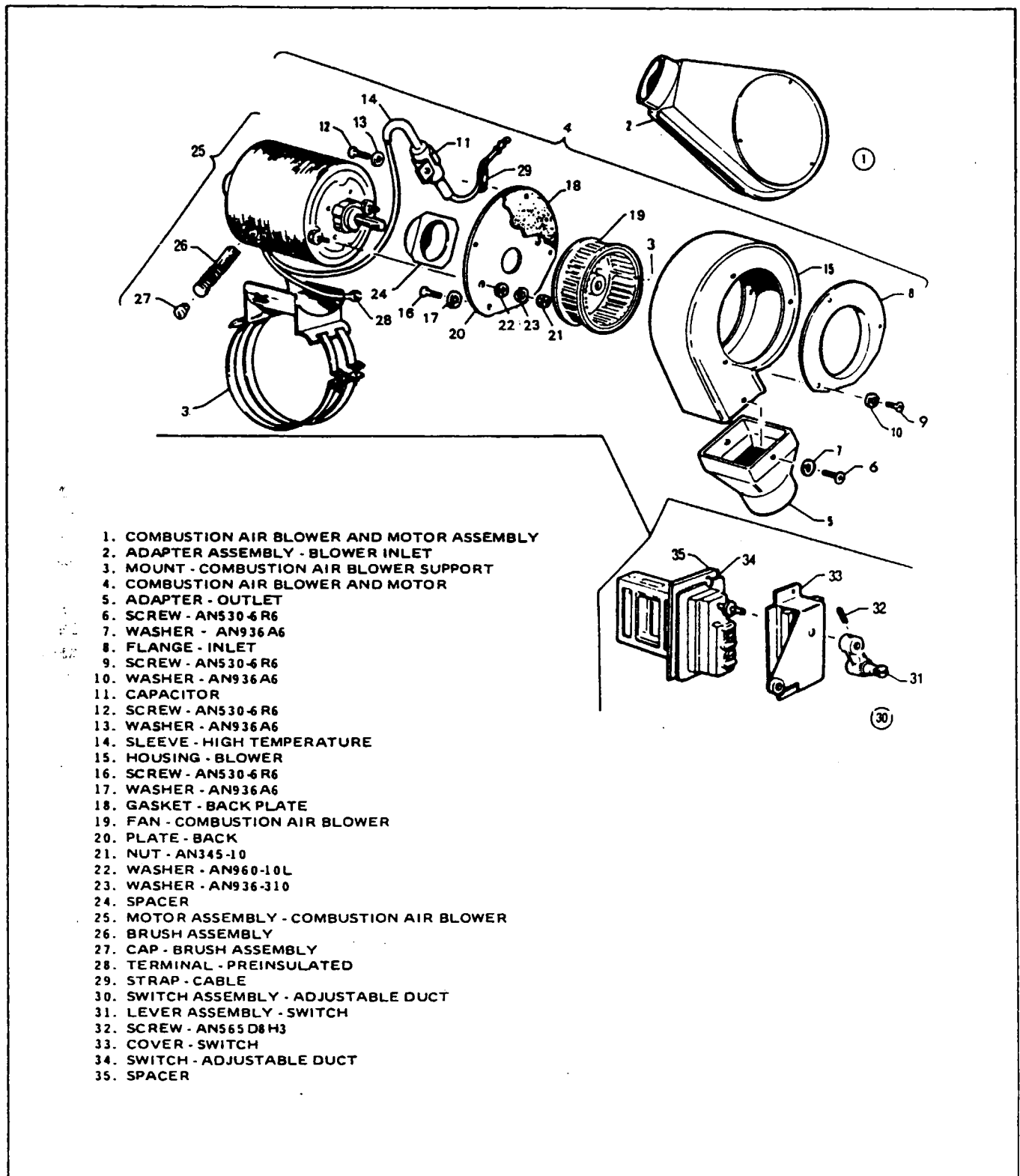
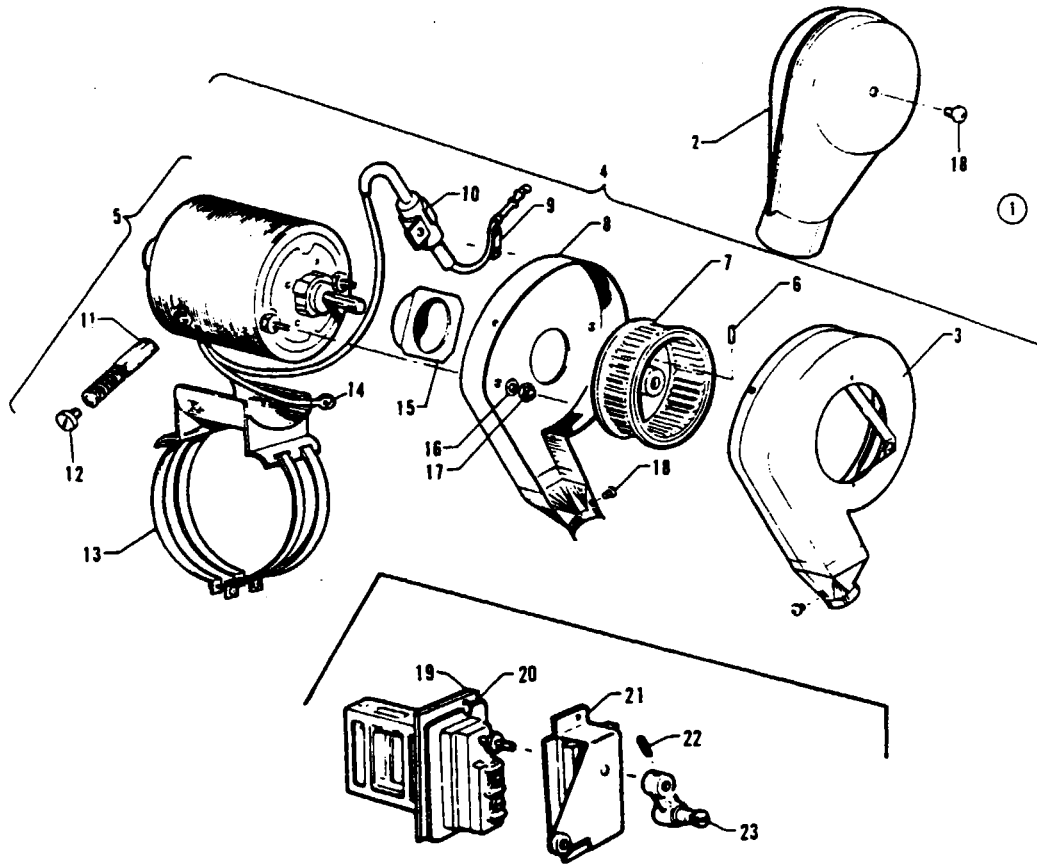

Figure 13-20. Exploded View - Combustion Air Blower and Motor Assembly (30,000 BTU)

PIPER SENECA II SERVICE MANUAL

1971



- | | |
|---|---|
| 1. COMBUSTION AIR BLOWER AND MOTOR ASSEMBLY | 13. MOUNT - COMBUSTION AIR BLOWER SUPPORT |
| 2. ADAPTER ASSEMBLY - BLOWER INLET | 14. ELECTRICAL LEAD |
| 3. HOUSING - BLOWER OUTER HALF | 15. SPACER |
| 4. COMBUSTION AIR BLOWER AND MOTOR | 16. WASHER |
| 5. MOTOR ASSEMBLY - COMBUSTION AIR BLOWER | 17. LOCK NUT - AN345-10 |
| 6. SET SCREW - BLOWER FAN | 18. SCREWS |
| 7. FAN - COMBUSTION AIR BLOWER | 19. SPACER |
| 8. HOUSING - BLOWER INNER HALF | 20. SWITCH - ADJUSTABLE DUCT |
| 9. STRAP - CABLE | 21. COVER - SWITCH |
| 10. CAPACITOR | 22. SCREW - AN565 D8 H3 |
| 11. BRUSH ASSEMBLY | 23. LEVER ASSEMBLY - SWITCH |
| 12. CAP - BRUSH ASSEMBLY | |

Figure 13-21. Exploded View - Combustion Air Blower and Motor Assembly (45,000 BTU)

Reissued: 10/11/79

HEATING AND VENTILATING

r. Center the fuel fitting in jacket opening. Position the fuel fitting shroud gasket (29), washer (41) and shroud (9); then install the nut (38) finger tight. Insert a 3/4 inch open-end wrench inside the jacket and hold the fuel-tube fitting while tightening the nut (38) with a 3/4 inch deep socket. Install the fuel solenoid elbow (34) and solenoid (22). Avoid twisting or damaging lead. Install wires through grommet in lower shroud (9).

s. Rotate the combustion air switch (26) onto the threaded fitting on the combustion air tube and tighten it firmly.

t. Install grommet (47) over pressure switch line. Connect the tube to the elbow fitting (33) on the combustion air pressure switch (26).

u. Install the wiring harness and connect all wire leads to their respective terminals. (Refer to the wiring diagram, Figure 13-7.) Place the grommet (45, Figure 13-19) in position in the jacket (5); locate the ventilating air blower (11) at the end of the jacket. Thread the quick-disconnect on the motor leads through the grommet and connect it to the mating connector on the wiring harness.

v. Place the blower housing in position on the jacket assembly (5) and secure it by installing the four screws (20), if removed at disassembly. This operation is easier if the screws (20) are started into their threads and the blower housing rotated into place allowing the screws to enter the notched openings in edge of blower housing. Tighten all screws securely.

w. Install the elbow adapter (23) with the screw.

x. After heater is installed in the aircraft and the fuel line is connected, install the upper fuel shroud box (10) with the screws. Ascertain that the grommet (40) is installed.

13-68. REASSEMBLY OF COMBUSTION AIR BLOWER ASSEMBLY (45,000 BTU). (Refer to Figure 13-21.)

a. Place the spacer (15) over the end of the motor shaft and attach the motor assembly (5) to the inner housing (8) with the two self-locking nuts (17), flat washers (16) and lock washers (00).

b. Slide the blower wheel (7) on the motor shaft and tighten the set screw (6) lightly against the flat portion of the motor shaft.

c. Place the outer blower housing (3) in position on the inner housing (8) and install screws (18).

d. Attach the radio-noise filter (10) at the point shown with the screw. The motor ground lead terminal can be grounded to the motor support bracket (13).

e. Loosen the Allen-head set screw in the blower wheel (7) and shift the wheel on the motor shaft until it is near the inlet in the blower housing. Tighten the set screw securely. The blower wheel should just clear the inlet flange when rotated at full RPM. Spin the blower wheel by hand for clearance check; then apply proper voltage to run motor and recheck for proper clearance.

f. Attach the blower inlet adapter (2) to blower housing (3) with screw (18).

13-69. TEST PROCEDURE.

13-70. GENERAL INFORMATION. A test of all components should have been made after overhaul to insure proper operation. Some shops may not have complete testing facilities for measuring airflows, pressure drops, and other factors which would be accomplished in a laboratory-type test. If such a test cannot be made, install the heater and check operation on the ground and in the air to determine if operation is normal. In shops where complete test equipment is available and a complete functional test can be performed, the test routine described in subsequent paragraphs should be made.

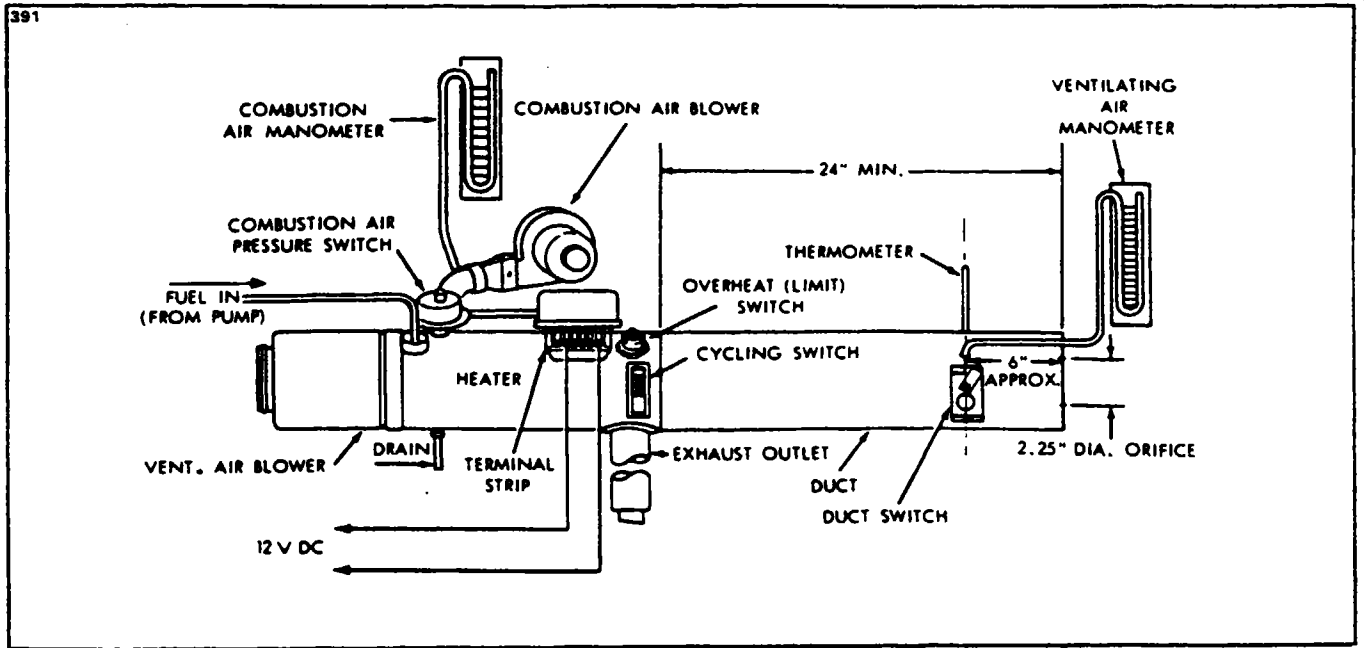

Figure 13-22. Suggested Setup of Heater Operation Test

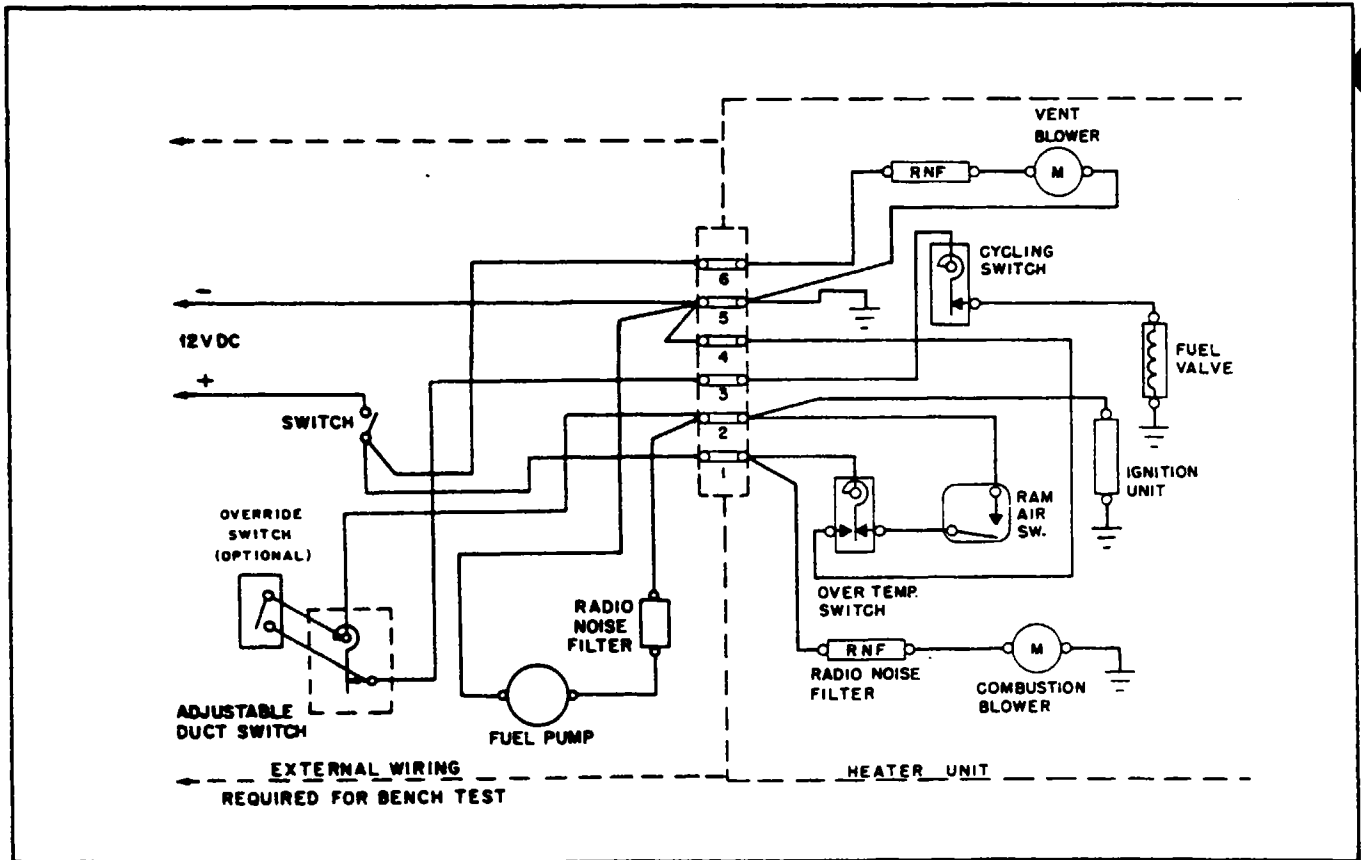

Figure 13-23. Wiring Connections for Heater Operation Test

13-71. EQUIPMENT REQUIRED. (Refer to Figure 13-22.)

- a. An improvised stand to hold the heater during test. The heater should be located far enough away from any combustible material or atmosphere to avoid hazard. A location should be chosen where exhaust can be dispelled. Do not add an excessive extension to the heater exhaust.
- b. A source of fuel capable of being regulated at seven psi.
- c. The combustion air blower to be used with the heater should be used for the test.
- d. A 12-volt current supply which may be a DC generator with a rheostat, ammeter, and voltmeter in the line to control and indicate the current draw and voltage output.
- e. Two water manometers (zero to 5.0 inch water column) for measuring the pressure in the ventilating air duct and in the combustion air stream.
- f. A piece of duct to be attached to the downstream end of the heater. It should have a minimum length of 24 inches and the same diameter as the heater being tested. A 2.25 inch diameter orifice should be centrally located at the outlet end. An aperture should be provided for the thermometer and duct switch and a static tap should be attached as shown in Figure 13-22.
- g. A thermometer with 500° F scale.
- h. A fuel-pressure gauge.
- i. A controlled source of compressed air for final leakage test.

13-72. OPERATION TEST (ON TEST BENCH). (Refer to Figures 13-22 and 13-23.)

- a. Connect the heater to the test setup as shown in Figure 13-22. Make sure the combustion air blower is mounted securely and that the heater is clamped to its supporting stand.
- b. Insert the duct switch in the sheet metal extension tube at the location shown in Figure 13-22.
- c. Connect components and heater as outlined in the wiring connection diagram, Figure 13-23. The power supply switch should be open.
- d. Connect the power source to the heater.
- e. Disconnect wire lead from terminal No. 3 on the heater side of heater terminal strip to prevent the heater from lighting and close the power source switch to check operation of blowers. The combustion air blower and ventilating air blower should operate at full speed with no blower wheel interference. If either blower fails to run, locate and correct the trouble before proceeding with the test.
- f. Connect a voltmeter from open side of combustion air pressure switch terminal to ground to determine if the switch is closed, which would be indicated by a full voltage reading on the meter. If a full voltage reading is not obtained, the combustion air supply is either inadequate or the switch is defective or improperly adjusted. Make necessary corrections.
- g. Observe the manometer connected to the ventilating air pressure tap, which should show a reading of 1.1 inches of water (minimum) at rated voltage.
- h. Observe the manometer connected to the combustion air tube tap, which should show a reading of 1.5 inches of water (minimum) at rated voltage.
- i. Open the power supply switch and reconnect the terminal lead disconnected in preceding Step e.
- j. Close the power supply switch and turn on the fuel supply. The heater should light within five seconds (may require slightly longer for air to be purged from fuel lines on the first trial).
- k. Observe operation of duct switch, which should control heater operation according to the switch setting.
- l. If the duct switch fails to control the temperature according to the setting, place the control lever in high "H" position and notice the control variation. A high reading of 250° F \pm 10° should be obtained (reading will vary in different applications).

m. Connect a jumper across the terminals of the duct switch to make it inoperative and observe action of the cycling switch. The cycling switch should cycle to control the outlet air temperature at approximately 250°F (nominal). This is a function of ambient temperature and airflow conditions. If operation is within a range of 190°F to 290°F, the switch is operating normally. If the switch is out of range, it can be reset in the same manner as described for the duct switch, except that no control lever or indicator stop are used. If adjustment fails to restore proper temperature range, replace the switch.

n. With duct switch still jumped, place a jumper across the cycling switch terminals to check operation of the overheat switch. Block the ventilating air outlet and notice if the overheat switch shuts off the heater. It should open at between 300°F and 400°F. (This is also a function of ambient temperature and airflow.) After the switch shuts off, remove ventilating air restriction; remove jumpers from cycling and duct switches and press firmly on the overheat switch reset button until it "clicks." The heater should light and operate.

o. Shut down the heater and check all components visually to make sure no damage has occurred to any of them.

p. Remove heater and other components from the test setup and install it in the airplane.

13-73. INSPECTION OF FUEL NOZZLE ORIFICE. (Refer to Figure 13-18 or 13-19.)

a. Loosen the four screws (20) and rotate the blower and motor housing (12) to disengage the ventilating air blower from the end of the heater jacket. It is not necessary to disconnect the electrical connections to remove the nozzle (21).

b. Remove the fuel shroud cover (10) by removing the screws. Remove solenoid and elbow.

c. Reach inside the inlet end of the jacket assembly with a 3/4 inch open-end wrench and, while holding the fuel-tube fitting of the jacket, use a 3/4 inch deep socket to remove the nut (38), washer and gasket (29) and lower fuel shroud box.

d. Remove the two screws and carefully withdraw the nozzle holder and valve assembly (21) from the combustion head assembly (6).

e. Carefully unscrew and remove the spray nozzle (21) from the nozzle holder. Remove the gasket (28).

f. After cleaning the nozzle, reinstall the parts removed in essentially the reverse order from removal. Be sure to hold the fuel-tube fitting when tightening the nut (38) to avoid damage to the fuel tube.

13-74. DEFROSTER BLOWER REMOVAL AND INSTALLATION. The defroster blower is located on the upper right forward side of fuselage bulkhead station 49.50. It is covered by a removable trim panel in the nose baggage compartment. Access to the blower and motor is accomplished by the removal of the baggage compartment trim panel and removal of the close out panel on the upper right side of bulkhead station 49.50, which the blower assembly is attached. Disconnect the electrical leads to the blower motor; loosen the clamps which secure the hoses to the blower housing and disconnect the hoses; then remove the two bolts which secure the blower assembly to the close out panel. Installation of the assembly is accomplished in the reverse order of removal.

PIPER SENECA II SERVICE MANUAL

GAUGE FOR LOCATING GROUND ELECTRODE IN JANITROL HEATERS

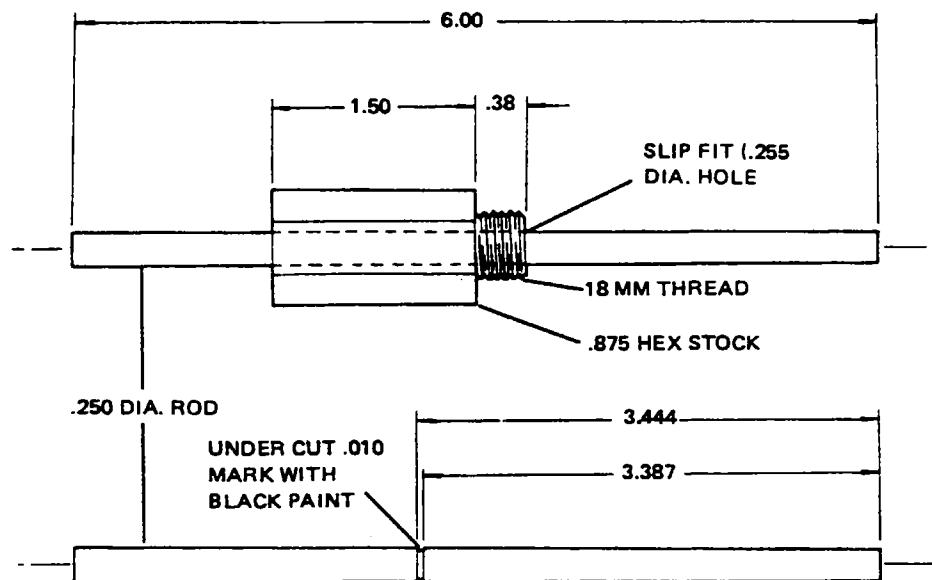

MATERIAL CAN BE SAE TYPE 303, 321 OR 347 ST. ST. OR ALUMINUM - CASE HARDENED

NOTE

This tool can be purchased from Piper Aircraft Corporation under Piper Part Number 55998-2.

Figure 13-24. Spark Plug Gap Adjustment Tool

Reissued: 10/11/79

HEATING AND VENTILATING SYSTEM

2L9

Island Enterprises

PIPER SENECA II SERVICE MANUAL

TABLE XIII-II. TROUBLESHOOTING CHART (JANITROL HEATER)

Trouble	Cause	Remedy
<p>Heater fails to light.</p>	<p>Heater switch or circuit breaker off.</p> <p>Low voltage supply.</p> <p>Fuel cut off from tank.</p> <p>Regulator not operating properly.</p>	<p>Turn on heater switch or close circuit breaker.</p> <p>Apply external power supply. Attempt to start heater. (Refer to Paragraph 13-12.)</p> <p>Turn on heater switch.</p> <p>Check for low pressure or replace regulator. (Refer to Paragraph 13-40.)</p>
<p align="center">NOTE</p> <p>When making the fuel pressure check, be sure fuel is flowing through the nozzle. The fuel regulator can be adjusted. Turn the adjusting screw clockwise to increase fuel pressure and counterclockwise to decrease it.</p>		
	<p>Restriction in fuel nozzle orifice.</p> <p>Fuel heater solenoid not operating.</p> <p>Fuel lines clogged or broken.</p>	<p>Remove the nozzle and clean or replace it. (Refer to Paragraph 13-73.)</p> <p>Remove and check solenoid. Replace if faulty. (Refer to Paragraphs 13-53 or 13-58, q; 13-57 or 13-62, k; and 13-65 or 13-67, a.)</p> <p>Inspect all lines and connections. It may be necessary to disconnect lines at various points to determine where the restriction is located.</p>

TABLE XIII-II. TROUBLESHOOTING CHART (JANITROL HEATER) (cont.)

Trouble	Cause	Remedy
<p>Heater fails to light. (cont.)</p>	<p>Ignition vibrator inoperative.</p> <p>Manual reset limit (overheat) switch open.</p> <p>Combustion air pressure switch open. (Defective switch or low combustion air blower output.)</p> <p>Cycling switch open.</p> <p>Duct switch open.</p>	<p>Replace vibrator. (Refer to Paragraphs 13-35 and 13-57 or 13-62.)</p> <p>Press reset button firmly (overheat light will illuminate when heater switch is on) and recheck to determine reason for switch opening.</p> <p>Check for low blower output due to low voltage and correct it. If switch is defective, replace it. (Refer to Paragraphs 13-17, a and 13-39.)</p> <p>Replace if defective. (Refer to Paragraph 13-38.)</p> <p>Operate control to see if switch will come on. Replace switch if defective. (Refer to Paragraph 13-51.)</p>
<p>Ventilating air blower fails to run.</p>	<p>Heater switch "OFF." Broken or loose wiring to motor.</p> <p>Circuit breaker open.</p> <p>Worn motor brushes.</p>	<p>Energize the heater switch. Check and repair wiring.</p> <p>Close circuit breaker.</p> <p>Replace motor brushes. (Refer to Paragraph 13-27, b.)</p>

PIPER SENECA II SERVICE MANUAL

TABLE XIII-II. TROUBLESHOOTING CHART (JANITROL HEATER) (cont.)

Trouble	Cause	Remedy
<p>Ventilating air blower fails to run. (cont.)</p>	<p>Blower wheel jammed.</p> <p>Motor burned out.</p> <p>Defective radio-noise filter.</p>	<p>Remove and check the ventilating air blower wheel and realign if necessary. (Refer to Paragraphs 13-65 or 13-67, g.)</p> <p>Remove blower assembly and replace motor. (Refer to Paragraphs 13-53 or 13-58, l and r thru u; 13-65 or 13-67, b thru g.)</p> <p>Replace filter.</p>
<p>Combustion air blower fails to run.</p>	<p>Faulty wiring to motor.</p> <p>Poor ground connection.</p> <p>Worn motor brushes.</p> <p>Blower wheel jammed. (Usually indicated by hot motor housing.)</p> <p>Defective radio-noise filter.</p> <p>Faulty or burned-out motor.</p>	<p>Inspect and replace faulty wiring.</p> <p>Tighten ground screw.</p> <p>Replace motor brushes. (Refer to Paragraph 13-27, b.)</p> <p>Overhaul the combustion air blower. (Refer to Paragraphs 13-53 or 13-58 and 13-65 or 13-67.)</p> <p>Replace filter. (Refer to Paragraphs 13-53 or 13-58 and 13-65 or 13-67.)</p> <p>Remove combustion air motor for overhaul or replacement of motor. (Refer to Paragraphs 13-27, 13-54 or 13-59 and 13-66 or 13-68.)</p>

TABLE XIII-II. TROUBLESHOOTING CHART (JANITROL HEATER) (cont.)

Trouble	Cause	Remedy
<p>Heater fires but burns unsteadily.</p>	<p>Insufficient fuel supply.</p> <p>Spark plug partially fouled.</p>	<p>Inspect fuel supply to heater, including shutoff valve, solenoid valve and fuel lines. Make necessary repairs.</p> <p>Replace spark plug. (Refer to Paragraph 13-28.) See Caution.</p>
<p style="text-align: center;">CAUTION</p> <p style="text-align: center;">Do not create a spark gap by holding the lead to the heater jacket. This can result in damage to the lead and ignition unit and the operator may receive an electrical shock.</p>		
	<p>Loose primary connection at ignition assembly.</p> <p>Faulty vibrator.</p> <p>Combustion air blower speed fluctuates. (Can be caused by low voltage, loose blower wheel, worn brushes or motor.)</p>	<p>Tighten the connection.</p> <p>Replace the vibrator. (Refer to Paragraph 13-35.)</p> <p>Remove and overhaul the combustion air blower assembly as required or correct low voltage condition. (Refer to Paragraphs 13-27, 13-54 or 13-59, 13-63 and 13-65 or 13-68.)</p>

PIPER SENECA II SERVICE MANUAL

TABLE XIII-II. TROUBLESHOOTING CHART (JANITROL HEATER) (cont.)

Trouble	Cause	Remedy
<p>Heater fires but burns unsteadily. (cont.)</p>	<p>High voltage leak in lead between ignition assembly and spark plug.</p> <p>Inoperative ignition assembly.</p> <p>Restriction in fuel nozzle orifice.</p> <p>Nozzle loose in retainer or improper spray angle.</p>	<p>Replace ignition assembly. (Refer to Paragraphs 13-30 or 13-31.)</p> <p>If vibrator is in good condition, replace ignition assembly only. (Refer to Paragraphs 13-30 or 13-31.)</p> <p>Remove nozzle for cleaning or replacement. (Refer to Paragraph 13-73.)</p> <p>Tighten or replace the nozzle as required. (Refer to Paragraphs 13-56 or 13-61, e; 13-65 or 13-67, k.)</p>
<p>Heater starts then goes out.</p>	<p>Lack of fuel at heater.</p> <p>Inoperative or chattering combustion air pressure switch.</p> <p>Inoperative overheat switch.</p>	<p>Check fuel supply through all components from the tank to the heater. Make necessary corrections.</p> <p>Adjust or replace switch. (Refer to Paragraph 13-39.)</p> <p>Replace switch. (Refer to Paragraphs 13-38 and 13-72.)</p>

PIPER SENECA II SERVICE MANUAL

TABLE XIII-II. TROUBLESHOOTING CHART (JANITROL HEATER) (cont.)

Trouble	Cause	Remedy
<p>Heater starts then goes out. (cont.)</p>	<p>Inoperative cycling switch.</p> <p>Low voltage.</p>	<p>Adjust or replace the switch. (Refer to Paragraphs 13-38 and 13-72.)</p> <p>Attach external power.</p>
<p>Heater fails to shut off.</p>	<p>Fuel solenoid valve in heater stuck open.</p> <p>Inoperative duct and cycling switch.</p> <p>Defective heater switch.</p>	<p>Remove and replace solenoid assembly. (Refer to Paragraphs 13-53 or 13-58, q; 13-57 or 13-62, k; and 13-65 or 13-67, a.)</p> <p>Check and repair. (Refer to Paragraphs 13-38 and 13-51.)</p> <p>Replace the heater switch.</p>

2L16 THRU 2L24
INTENTIONALLY LEFT BLANK



SENECA II
SERVICE MANUAL

CARD 3 OF 3

PA-34-200T SENECA II

PIPER AIRCRAFT CORPORATION

(PART NUMBER 761 590)

3A1

AEROFICHE EXPLANATION AND REVISION STATUS

Service manual information incorporated in this set of Aerofiche cards is arranged in accordance with the general specifications of Aerofiche adopted by the General Aviation Manufacturer's Association. Information compiled in this Aerofiche service manual is kept current by revisions distributed periodically. These revisions supersede all previous revisions, are complete Aerofiche card replacements, and supersede Aerofiche cards of the same number in the set.

Identification of revised material:

Revised text and illustrations are indicated by a black vertical line along the left-hand margin of the frame, opposite revised or added material. Revision lines indicate only current revisions with changes and additions to existing text and illustrations. Changes in capitalization, spelling, punctuation, indexing, physical location of the material, or complete page additions are not identified by revision lines.

Revisions to Service Manual 761 590 issued October 11, 1979 are as follows:

Effectivity	Publication Date	Aerofiche Card Effectivity
ORG791011	October 11, 1979	1, 2 and 3
PR800810	August 10, 1980	1, 2 and 3
PR810316	March 16, 1981	1, 2 and 3
PR821112	November 12, 1982	1, 2 and 3
PR831208	December 8, 1983	1, 2 and 3
IR860730	July 30, 1986	1
IR860920	September 20, 1986	1
IR870506*	June 12, 1987	1

This publication contains material revised as of December 8, 1983 (with three interim revisions effective July 30, 1986, September 20, 1986, and May 6, 1987).

*** INTERIM CHANGE**

Revisions appear in Table III-I of card 1. There are no other changes in this service manual. Please discard your current card 1 and replace it with this revised one. DO NOT DISCARD CARDS 2 or 3.

The date on Aerofiche cards must not be earlier than the date noted for the respective card effectivity. Consult the latest card in this series for current Aerofiche card effectivity.

TABLE OF CONTENTS

	AEROFICHE CARD NO. 1	GRID NO.
I	INTRODUCTION	1A13
II	HANDLING AND SERVICING	1A16
III	INSPECTION	1C23
IV	STRUCTURES	1D12
V	SURFACE CONTROLS	1F21
VI	HYDRAULIC SYSTEM	1I3
VII	LANDING GEAR AND BRAKE SYSTEM	1J5

AEROFICHE CARD NO. 2

VIII	POWERPLANT	2A9
IX	FUEL SYSTEM	2D4
X	INSTRUMENTS	2E8
XI	ELECTRICAL SYSTEM	2F16
XII	ELECTRONICS	2I20
XIII	HEATING AND VENTILATING SYSTEM	2J6

AEROFICHE CARD NO. 3

XIV	ACCESSORIES AND UTILITIES	3A6
-----	---------------------------------	-----

PIPER SENECA II SERVICE MANUAL

LIST OF ILLUSTRATIONS

Figure		Aerofiche Grid No.
14-1.	Propeller Deicer Installation	3A12
14-2.	Electrical Diagram Showing Cycle Sequence - Phase I	3A13
14-3.	Electrical Diagram Showing Cycle Sequence - Phase II	3A13
14-4.	Electrical Diagram Showing Cycle Sequence - Phase III	3A14
14-5.	Electrical Diagram Showing Cycle Sequence - Phase IV	3A14
14-6.	Typical Use of Dial Indicator	3A16
14-7.	Centering of Brushes on Slip Rings	3A17
14-8.	Wiring Schematic - Electric Propeller Deicing System	3A19
14-9.	Brush Block Assembly	3A20
14-10.	Brush Module Assembly	3A22
14-10a.	Alternate Module Stacking Arrangement	3A22
14-10b.	Modular Brush Assembly 3E2042-1 (2 Bladed Prop)	3A23
14-10c.	Modular Brush Assembly 3E2062-2 (3 Bladed Prop)	3A23
14-10d.	Angle of Contact Brushes to Slip Rings	3A24
14-11.	Propeller Deicer Installation	3B1
14-12.	Installation of Deicer Boot	3B3
14-13.	Wrinkled Deicers	3B6
14-14.	Sealer Application (Boot)	3B7
14-15.	Pneumatic Deicer System Installation (S/N's to 34-8070144)	3B15
14-15a.	Pneumatic Deicer Systems Installation (S/N 34-8070144 and up)	3B16
14-16.	Pneumatic Deicer Boots Operation	3B18
14-17.	Pneumatic Deicer System Schematic	3B18
14-18.	Ice Detection Light Schematic	3C9
14-19.	Portable Oxygen Installation	3C15
14-20.	Fixed Oxygen System Installation (Optional)	3C16
14-20a.	Oxygen Tubing Installations	3C17
14-21.	Oxygen System Filler Valve Installation	3C18
14-22.	Oxygen Cylinder and Regulator Assembly	3C18
14-23.	Oxygen Pressure Gauge Installation	3C20
14-24.	Air Conditioning System Installation	3C24
14-25.	Test Gauge and Manifold Set	3D5
14-26.	Manifold Set Operation	3D6
14-27.	Leak Test Hookup	3D7
14-28.	Evacuation Hookup	3D9
14-29.	Charging Stand	3D11
14-30.	Charging Hookup	3D12
14-31.	Top Dead Center Casting Mark (Sankyo Compressor)	3D15
14-32.	Rotation of Clutch Front Plate (Sankyo Compressor)	3D15
14-33.	Condenser Air Scoop Installation	3D19
14-34.	Expansion Valve	3D20
14-35.	Components Installation	3D22
14-36.	Air Conditioning Wiring Schematic (Early Models)	3E1
14-37.	Synchrophaser Wiring Schematic Auto Synch/Manual Switch	3E11
14-37a.	Synchrophaser Wiring Schematic (Phase Adjustment Switch)	3E12
14-38.	Engine Synchrophaser Installation	3E13
14-39.	Pulse Generator Installation	3E15

LIST OF TABLES

Table		Aerofiche Grid No.
XIV-I.	Required Materials for Repair of Propeller Deicer	3B3
XIV-II.	Mixing of Materials	3B5
XIV-III.	Electrical Resistance	3B7
XIV-IV.	Troubleshooting Chart (Propeller Deicer System)	3B9
XIV-V.	Operating Pressures.....	3B21
XIV-VI.	Materials and Supplies for Cold Repair	3B24
XIV-VII.	Troubleshooting Chart (Pneumatic Deicer System)	3C7
XIV-VIII.	Oxygen System Components Limits	3C13
XIV-IX.	Troubleshooting Chart (Oxygen System)	3C21
XIV-X.	Temperature Pressure Chart	3D1
XIV-XI.	Aluminum Tubing Torque	3D4
XIV-XII.	Blower System Wire Color Codes	3D24
XIV-XIII.	Troubleshooting Chart (Air Conditioner).....	3E2

SECTION XIV

ACCESSORIES AND UTILITIES

Paragraph		Aerofiche Grid. No.
14-1.	Introduction	3A10
14-2.	Troubleshooting	3A10
14-3.	Propeller Deicing System	3A10
	14-4. Description and Principles of Operation	3A10
	14-5. Deicer System Operational Check	3A11
	14-6. Troubleshooting	3A11
	14-7. Using the Ammeter	3A11
	14-8. Helpful Tips	3A11
14-9.	Inspection	3A15
	14-10. 50 Hour Inspection	3A15
	14-11. 100 Hour Inspection	3A15
14-12.	Repair Procedures for Individual Components	3A17
	14-13. Brush Retainer Replacement	3A17
	14-14. Individual Brush Replacement	3A18
	14-15. Alignment of New Brushes	3A18
14-16.	Slip Rings	3A18
	14-17. Alignment of Slip Ring Assembly	3A18
	14-18. Replacement of Slip Ring Assembly	3A18
	14-18a. Replacement of Brush Block with Modular Brush Assemblies	3A21
	14-18b. Brush Module Replacement	3A21
14-19.	Deicer Blades	3A21
	14-20. Resistance Check of Deicer Blade	3A21
	14-21. Replacement	3A21
	14-22. Removal of Deicer	3B2
	14-23. Blade Preparation	3B2
	14-24. Cement Application	3B4
	14-25. Installation of Deicer and Required Materials	3B4
	14-26. Preparation and Application of Sealer	3B5
	14-27. Wrinkled Deicers	3B6
	14-28. Electrical Check	3B6
	14-29. Installation of Deicer Wiring Harness	3B8
	14-30. Balancing	3B8
	14-31. Final Electric Check	3B8
	14-32. Other Components	3B8
	14-33. Timer Test	3B8
14-34.	Pneumatic Deicing System	3B17
	14-35. Introduction	3B17
	14-36. Description and Principles of Operation	3B17
14-37.	Troubleshooting	3B17
	14-38. Operational Check	3B17
	14-39. Electrical Test	3B17
	14-40. Pressure Leakage Test	3B19
	14-41. Pneumatic Regulator Adjustment	3B19

14-42.	Component Maintenance and Replacement	3B20
14-43.	Filter Replacement	3B20
14-44.	Control Valves	3B20
14-45.	Timer	3B20
14-46.	Inspections	3B21
14-47.	Ground Procedure	3B21
14-48.	100 Hour Inspection	3B21
14-49.	Removal of Boots	3B22
14-50.	Repair of Boots	3B22
14-51.	Cold Repair	3B23
14-52.	Vulcanized Repairs	3C2
14-53.	Installation	3C2
14-54.	Preparation of Leading Edges	3C2
14-55.	Preparation of Deicer	3C2
14-56.	Mounting Deicer on Leading Edge	3C2
14-57.	Adhesion Test	3C4
14-58.	Maintenance	3C4
14-59.	Icex Application	3C5
14-60.	Resurfacing Conductive Cement	3C5
14-61.	Ice Detection Light	3C9
14-62.	Introduction	3C9
14-63.	Description and Operation	3C9
14-64.	Servicing	3C9
14-65.	Removal	3C9
14-66.	Installation	3C9
14-67.	Heated Windshield Panel	3C10
14-68.	Description	3C10
14-69.	Removal and Installation of Heated Panel	3C10
14-70.	Oxygen System	3C11
14-71.	Description and Principle of Operation	3C11
14-72.	Troubleshooting	3C11
14-73.	Safety Precautions	3C11
14-74.	Inspection and Overhaul Time Limits	3C11
14-75.	Testing for Leaks	3C12
14-76.	Maintenance	3C12
14-77.	Cleaning Operations	3C12
14-78.	Purging the System	3C13
14-79.	Removal of Portable Oxygen Unit	3C14
14-80.	Charging	3C14
14-81.	Removal of Outlets	3C14
14-82.	Installation of Outlets	3C14
14-83.	Cleaning of Masks (Portable System)	3C15
14-84.	Cleaning of Face Masks (Fixed System)	3C15
14-85.	Removal of Oxygen Cylinder and Regulator (Fixed System)	3C16
14-86.	Installation of Oxygen Cylinder and Regulator (Fixed System)	3C19
14-87.	Removal of Filler Valve	3C19
14-88.	Installation of Filler Valve	3C19
14-88a.	Oxygen Tubing Clearance	3C19
14-89.	Removal of Pressure Gauge	3C20
14-90.	Installation of Pressure Gauge	3C20
14-91.	Removal of Outlets	3C20
14-92.	Installation of Outlets	3C22
14-92a.	Thread Sealant	3C22

Revised: 3/16/81

3A7

Paragraph

Aerofiche
Grid No.

14-93.	Air Conditioning Installation	3C23
14-94.	Description	3C23
14-95.	Air Conditioning System Operation	3C23
14-96.	Malfunction Detection	3D2
14-97.	Special Servicing Procedures	3D3
14-98.	Service Valves	3D4
14-99.	Test Gauge and Manifold Set	3D5
14-100.	Checking the System for Leaks	3D7
14-101.	Leak Check - Method I	3D7
14-102.	Leak Check - Method II	3D8
14-103.	Discharging	3D8
14-104.	Evacuating the System	3D8
14-105.	Charging the System	3D10
14-106.	With a Charging Stand	3D10
14-107.	Using the Airplane Compressor to Charge the System	3D11
14-108.	Addition of Partial Charge to System	3D13
14-109.	Compressor Service	3D13
14-110.	Compressor Removal	3D14
14-111.	Compressor Installation	3D14
14-112.	Check Compressor Oil	3D14
14-113.	Adjustment of Drive Belt Tension	3D16
14-114.	Refrigerant Lines and Routing	3D16
14-115.	Receiver - Dehydrator	3D16
14-116.	Receiver - Dehydrator Removal	3D16
14-117.	Receiver - Dehydrator Installation	3D17
14-118.	Condenser	3D17
14-119.	Condenser Removal	3D17
14-120.	Condenser Installation	3D17
14-121.	Condenser Scoop Rigging Instructions	3D18
14-122.	Expansion Valve	3D20
14-123.	Expansion Valve Removal	3D20
14-124.	Expansion Valve Installation	3D20
14-125.	Evaporator Assembly	3D21
14-126.	Evaporator Assembly Removal	3D21
14-127.	Evaporator Assembly Installation	3D21
14-128.	Pressure Relief Switch (Texas Instruments)	3D22
14-129.	Electrical Installation	3D22
14-130.	Fuse Replacement	3D22
14-131.	Overhead Vent Blower	3D23
14-132.	Description	3D23
14-133.	Removal of Blower Assembly	3D23
14-134.	Disassembly of Blower Assembly	3D23
14-135.	Reassembly of Blower Assembly	3D23
14-136.	Installation of Blower Assembly	3D23
14-137.	Shoulder Harness Inertia Reel Adjustment	3D24

Paragraph

**Aerofiche
Grid No.**

14-138.	Engine Synchrophaser.....	3E9
14-139.	Description of Synchrophaser System	3E9
14-140.	System Operating Procedure	3E9
14-140a.	Inductor and Kit Installations	3E10
14-141.	Synchrophaser System Check and Adjustment.....	3E10
14-142.	Ground Checks	3E10
14-143.	Flight Check	3E14
14-144.	Removal of Computer Assembly	3E14
14-145.	Installation of Computer Assembly	3E14
14-146.	Removal of Pulse Generator	3E15
14-147.	Installation of Pulse Generator	3E15

Revised: 8/10/80

3A9

SECTION XIV

ACCESSORIES AND UTILITIES

14-1. INTRODUCTION. This section covers accessories which are available for this airplane and not covered in other sections of this Service Manual. This information provides instructions for remedying difficulties which may arise in any of the accessories, and the instructions are organized so the mechanic may refer to whichever component or system he must service.

14-2. TROUBLESHOOTING. A troubleshooting chart is located at the end of each accessory covered in this section. The various troubles and suggested remedies found in the tables are provided to assist in locating and correcting malfunctions in the particular system.

14-3. PROPELLER DEICING SYSTEM.

14-4. DESCRIPTION AND PRINCIPLES OF OPERATION. (Refer to Figure 14-1.) The Propeller Deicing System consists of an electrically heated deicer (1) bonded to each propeller blade, a slip ring assembly (2) with a brush block assembly (3) to transfer electrical power to the rotating deicers, a timer (4), an ammeter (5), a control switch circuit breaker (7), shunt (6), together with wiring harnesses (8) to complete the circuit. Power is drawn from the aircraft electrical system (10).

Dual element deicers are utilized on the two blade propeller installation. Each deicer has two separate heaters; one for the outer half and one for the inner half. By heating all outer or inner heaters on only one propeller at a time, rotational balance is held during deicing. Current is drawn from the airplane electrical system through the switch, ammeter and timer. The timer successively delivers current via the slip ring and brush block arrangement to (phase 1) the outer heaters on the right propeller, (phase 2) the inner heaters on the same propeller, (phase 3) the outer heaters of the left propeller and (phase 4) the inner heaters on the left propeller. The timer energizes each of these four phases in turn for about 34 seconds and then repeats the cycle as long as the control switch is on. The cycling sequence given is vital so that outboard heaters on each propeller operate before the inboard heaters. See cycle sequence. (Refer to Figures 14-2 thru 14-5.) The system may be used continuously in flight if needed. To conserve electrical power, current is cycled to the deicer heaters at timed intervals rather than continuously.

NOTE

Heating may begin at any phase in the cycle depending on the timer position when the switch was turned off from previous use.

The optional McCauley three bladed propeller installation utilizes single element deicers. When the switch is turned on power is directed through the brush block and slip ring to all the heating elements on one propeller for approximately 34 seconds. The timer then directs the power to the other propeller for approximately 34 seconds. This cycle continues until the switch is turned off.

a. Deicers: The deicers contain special heater wires protected by fabric plies and by oil and abrasion-resistant rubber. The side of the deicer cemented to the propeller has a dull finish whereas the air side finish is "glossy."

Dual element deicers have a separate lead for the inboard and outboard heater and a third lead which is a common ground. These leads are so marked. An unmarked ground can be identified by using an ohmmeter across the three possible pairs of leads. One pair will show twice the resistance of the other pairs. The latter are the "hot" leads and the lead excluded from the pair that shows twice the resistance of the other pairs is the ground lead.

Single element deicers have only two leads; one input and one ground.

b. Slip Rings, Brushes and Brush Blocks: To transfer electrical power to the rotating deicers, a brush block assembly is mounted to the engine by means of a bracket and has brushes which are spring-loaded to press against the revolving slip rings.

c. Timer: The timer is a sealed unit. If found inoperative, it must be replaced as an assembly - no field repairs are authorized.

d. Ammeter: The ammeter is designed for each particular system and it is therefore important that the correct replacement part number be used if replacement should be required. In the event of low aircraft battery voltage (very possible in ground checks), the ammeter readings will be lower than at full voltage. Provided the ammeter needle reads in the shaded range on the scale (full aircraft voltage), current flow is considered as normal.

e. Switch: The switch-circuit breaker is mounted in the switch and circuit breaker control panel.

14-5. DEICER SYSTEM OPERATIONAL CHECK.

a. Chock the wheels and operate the engine at near takeoff power.

b. Turn deicer system switch ON and observe deicer ammeter for at least two minutes.

c. The ammeter needle must "flicker" approximately every 34 seconds as the step switch of the timer operates.

d. With engines stopped, turn deicer switch ON and feel deicers on propellers for proper sequence of heater operation.

e. The starting point is not important but the sequence is vital and must be: Right Outboard, Right Inboard, Left Outboard, Left Inboard Heaters, in that order.

f. Temperature rise should be noticeable and each heater should warm for about 34 seconds.

g. Local hot spots indicate surface damage of deicer heaters and should be repaired.

14-6. TROUBLESHOOTING. Troubles peculiar to the deicing system are listed in Table XIV-IV at the end of these instructions, along with their probable causes and suggested remedies.

14-7. USING THE AMMETER. Whether in flight or during ground testing, the ammeter can be used to indicate the general nature of most electrical problems. The troubleshooting chart is primarily based on this use of the ammeter and assumes that the user does understand all normal operating modes of the system as given in Paragraph 14-4.

NOTE

When troubleshooting, first use the "ammeter test" and "heat test" to determine which circuits are involved. Use circuit diagram, Figure 14-8, for assistance to check voltages or continuity.

14-8. HELPFUL TIPS.

a. If the ammeter reading drops to one-third normal current, this indicates that one heater circuit is open or, on the dual element deicer, possibly improper connections are allowing both inboard and outboard units to heat at the same time.

b. Excess current reading on the ammeter always indicates a power lead is shorted to ground. Thus, when trouble of this nature is found, it is vital that the grounded power lead be located and corrected.

c. A considerable number of timers that have been returned for repair proved to be fully workable when tested. Accomplish the test described in Paragraph 14-33 before concluding that the timer is defective.

2029

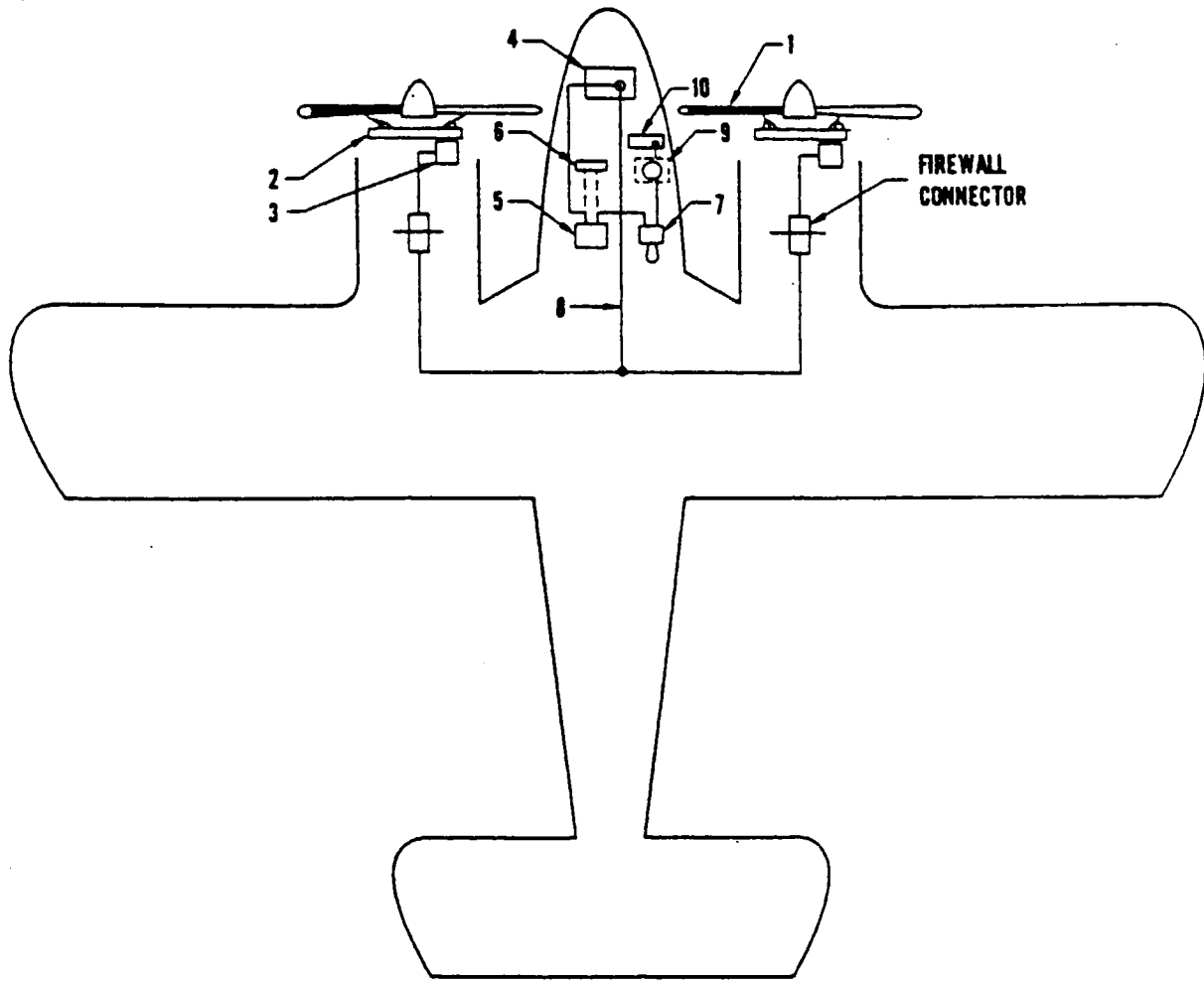

- 1. DE-ICER
- 2. SLIP RING
- 3. BRUSH BLOCK
- 4. TIMER
- 5. AMMETER
- 6. SHUNT
- 7. SWITCH
- 8. WIRING
- 9. CIRCUIT BREAKER
- 10. AIRCRAFT POWERSOURCE

Figure 14-1. Propeller Deicing Installation

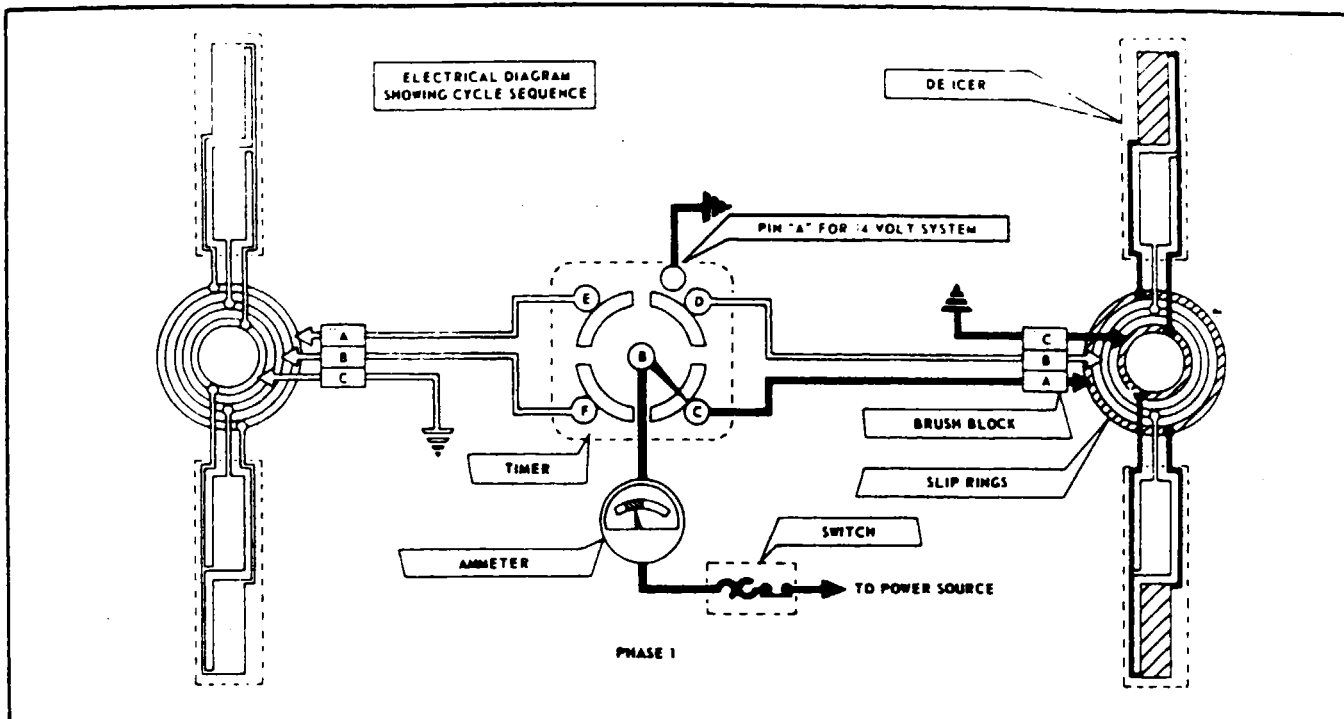

Figure 14-2. Electrical Diagram Showing Cycle Sequence - Phase I

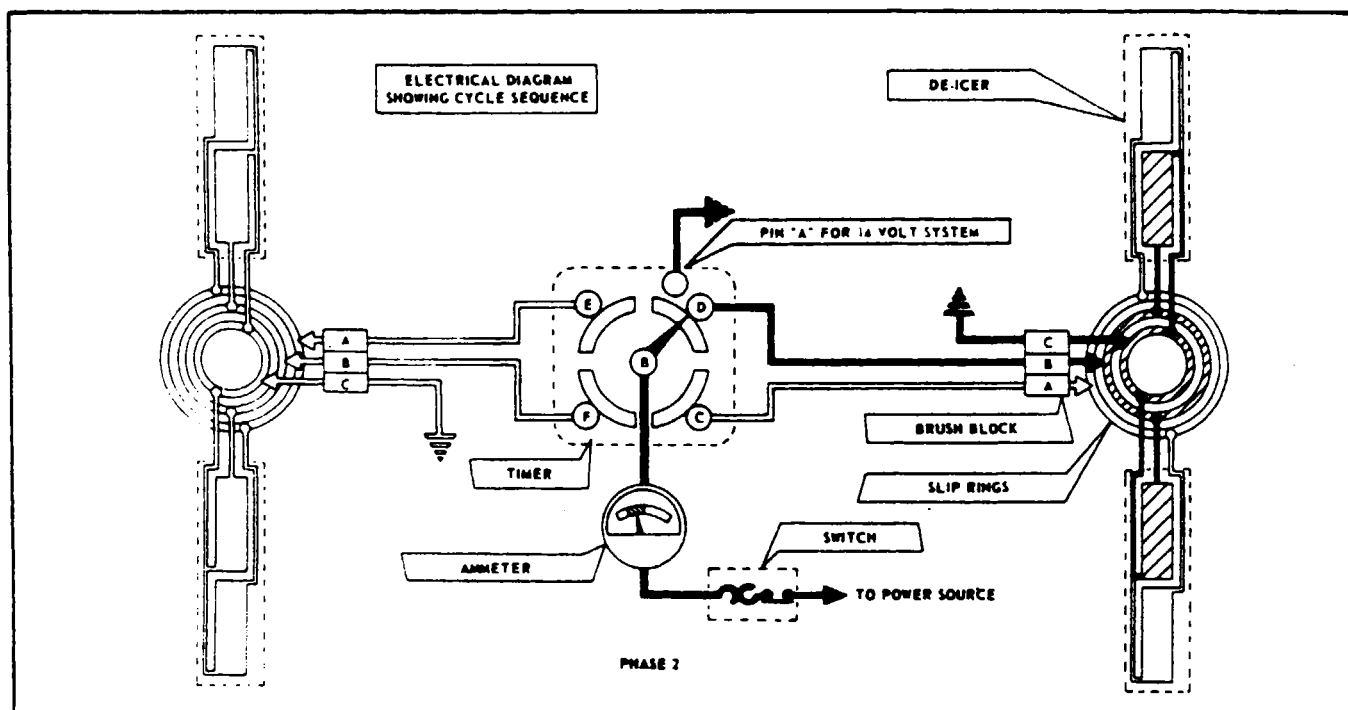

Figure 14-3. Electrical Diagram Showing Cycle Sequence - Phase II

Reissued: 10/11/79

ACCESSORIES AND UTILITIES

3A13

PIPER SENECA II SERVICE MANUAL

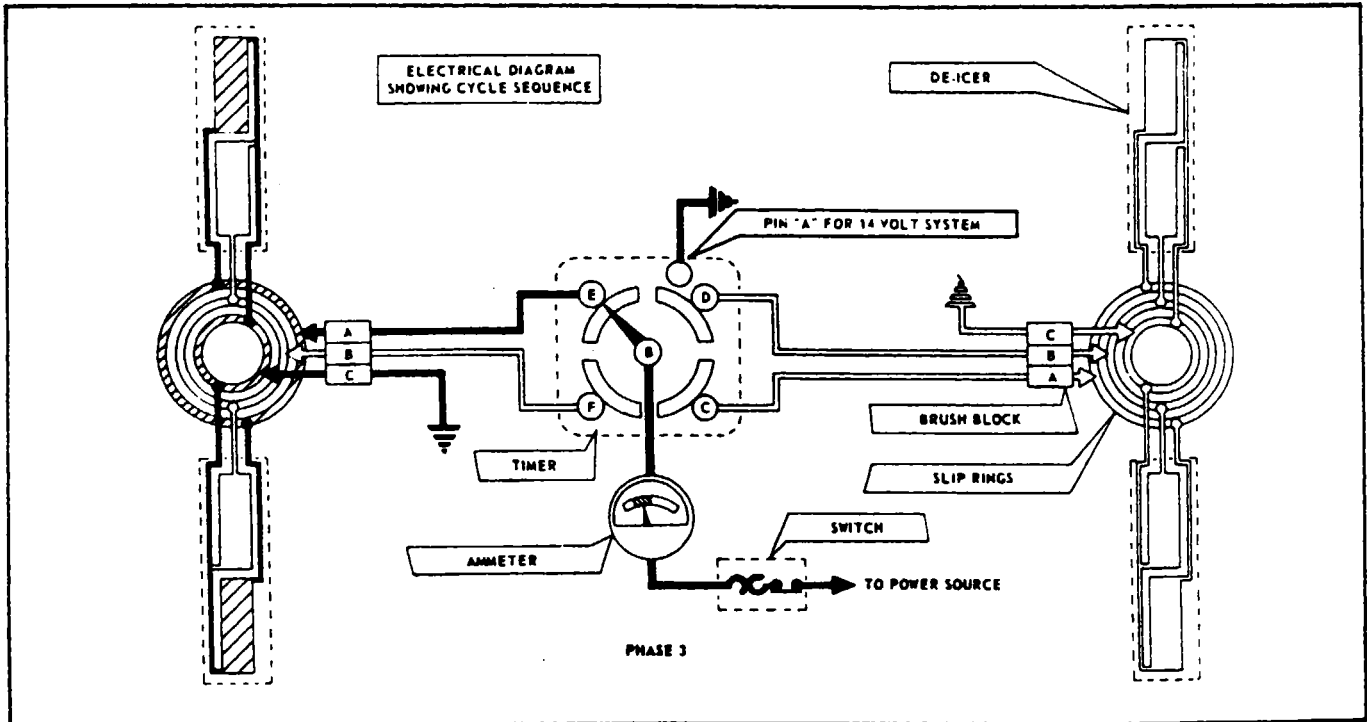

Figure 14-4. Electrical Diagram Showing Cycle Sequence - Phase III

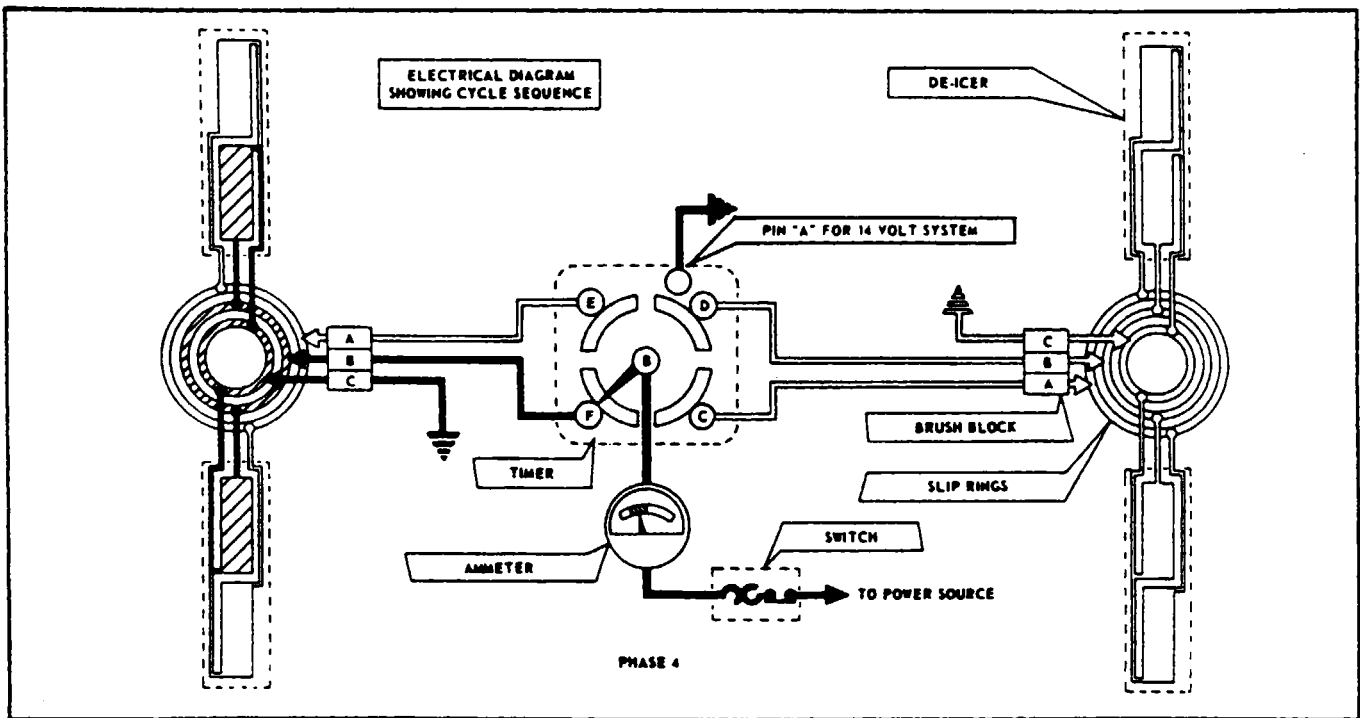

Figure 14-5. Electrical Diagram Showing Cycle Sequence - Phase IV

14-9. INSPECTION.

14-10. 50 HOUR INSPECTION.

a. Lock brakes and operate engines at near takeoff power. Turn deicer system switch ON and observe deicer ammeter for at least two minutes. Ammeter needle must rest within the shaded band except for a "flicker," approximately every 34 seconds, as the step switch of the timer operates. If not, refer to the appropriate entry of the troubleshooting chart.

b. With engines stopped, turn deicer switch ON and feel deicers on propellers for proper sequence of heater operation. The starting point is not important but sequence is vital and must be: Right Outboard, Right Inboard, Left Outboard and Left Inboard Heaters, in that order. Temperature rise should be noticeable and each heater should warm for about 34 seconds. Local hot spots indicate surface damage of deicer heaters; inspect and repair in accordance with Paragraphs 14-21 to 14-24.

c. Remove spinner dome and engine cowling. With assistant observing deicer ammeter and with deicer switch ON, flex all accessible wiring, particularly the deicer lead straps, leads from slip ring assembly, and the fire wall electrical connectors and their wiring. Any movement of the ammeter needle other than the "34 second flicker" of cycling indicates a short or open that must be located and corrected.

14-11. 100 HOUR INSPECTION.

a. Remove cowling in accordance with Removal of Engine Cowling, Section VIII.

b. Conduct 50 hour inspection.

c. Check for radio noise or radio compass interference by operating the engine at near takeoff power and with radio gear ON while turning deicer switch ON and OFF. If noise or interference occurs with deicer switch ON and disappears when switch is OFF, see troubleshooting chart.

d. Ascertain that all clamps, clips, mountings and electrical connections are tight. Check for loose, broken or missing safety wire.

e. Deicers: Closely check deicers for wrinkled, loose or torn areas, particularly around the outboard end and where the strap passes under the strap retainer. Look for abrasion or cuts, especially along the leading edge and the flat or thrust face. If heater wires are exposed in damaged areas or if rubber is found to be tacky, swollen or deteriorated (as from oil or solvent contact), replace the damaged deicer in accordance with Paragraphs 14-24 to 14-29.

NOTE

Check the strap restrainers are correctly located and secure. Look for cracks or other damage. Operate propeller from "full pitch" to "feathering" and check that deicer lead straps do not come under tension or are pinched by propeller blade. (Refer to Figure 14-11.)

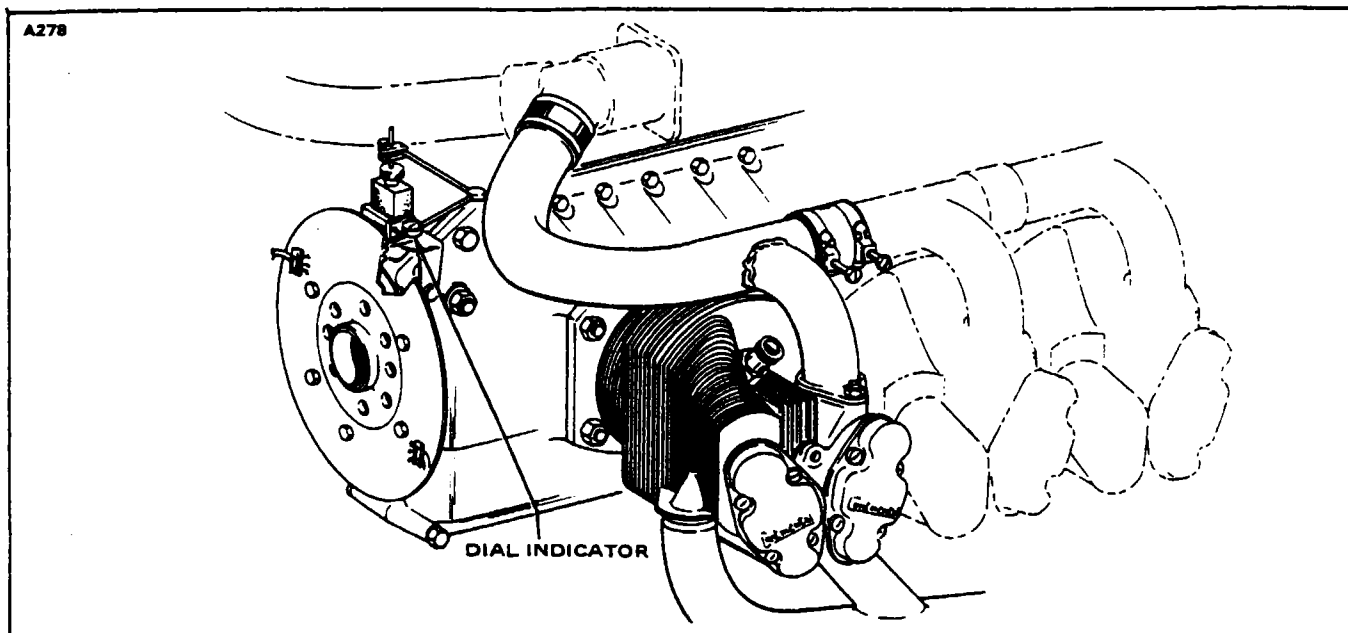

Figure 14-6. Typical Use of Dial Indicator

f. Slip Rings: Check slip rings for gouges, roughened surface, cracks, burned or discolored areas, and for deposits of oil, grease or dirt.

1. Clean greasy or contaminated slip rings with CRC 2-26 solvent. (This solvent is available from C.R.C. Chemical Division, Webb Inc., C-J10 Limekiln Pike, Dreshner, Penna. 19025.)

2. If uneven wear is found or if wobble is noticed, set up dial indicator as shown in Figure 14-6 to check alignment of slip rings to propeller shaft per Paragraph 14-17.

g. Brush Block - Brushes: Examine mounting brackets and housing for cracks, deformation or other physical damage.

1. Test that each brush rides fully on its slip ring over 360°. Figure 14-7 shows the wear pattern if this condition is not corrected. If alignment is off, shim where brush block is mounted to bracket or adjust mounting bracket support arm.

NOTE

The shim is a series of laminates and may be peeled for proper alignment of brushes to slip ring.

2. Check for proper clearance of brush block to slip rings as shown in Figure 14-10d. If not correct, loosen mounting screws and move in elongated holes to correct block position before tightening securely.

3. Visually check brush block for approximately 2° angle of attack. (Refer to Figure 14-10d.) If not, loosen mounting screws and twist block, but be sure to hold clearance limits shown when tightening.

h. System Wiring: With deicer system operating, have assistant observe ammeter while visually inspecting and physically flexing wiring from brush blocks through fire wall, to timer, to ammeter, to switch and to aircraft power supply. The ammeter will flicker as the timer switches approximately every 34 seconds in the cycle. Jumps or flickers at other times indicates loose or broken wiring in the area under examination at that moment. In such case, check continuity through affected harness, while flexing and prodding each wire in the area that gave initial indication of trouble. Use the wiring diagram in Figure 14-8 to trace circuitry.

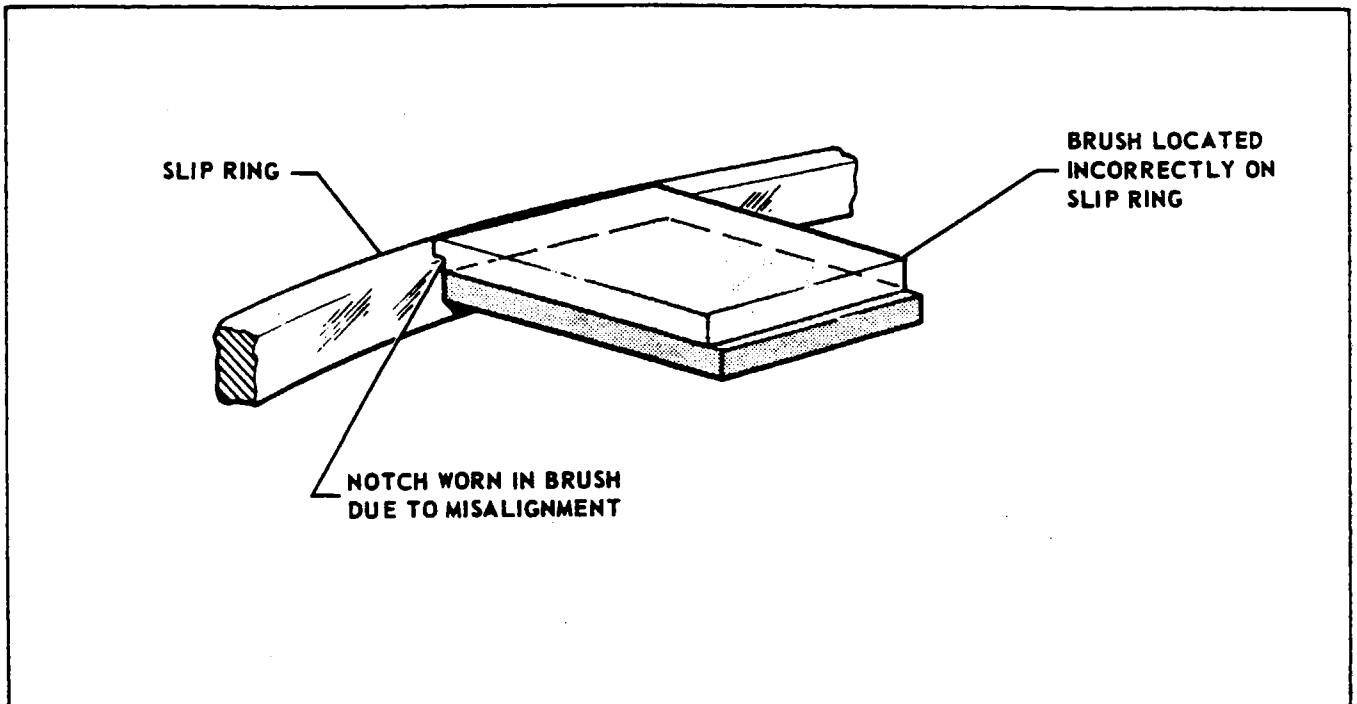

Figure 14-7. Centering of Brushes on Slip Rings

14-12. REPAIR PROCEDURES FOR INDIVIDUAL COMPONENTS.

14-13. BRUSH RETAINER REPLACEMENT. Brushes should be replaced when .375 inch of brush material remains; brushes must be replaced when .250 inch remains. Measure the brushes as shown in Figure 14-9. Replace the brush retainer as follows:

- a. Remove the brush block assembly from the mounting bracket by removing attachment hardware.
- b. Remove screws and separate brush retainer assembly from guide block. Note orientation of terminals.

NOTE

When separating brush retainer block, guide block and brush retainer assembly; move guide block laterally to disengage dowel pin grooves.

- c. Discard old brush retainer assembly.
- d. Determine correct orientation of brushes to receptacle (refer to Figure 14-9) and carefully insert brushes into brush guide block slots. When reassembling brush retainer assembly, align receptacle as shown in Figure 14-9.

CAUTION

Avoid side loads on brushes; brushes are extremely fragile.

- e. Reinstall brush retainer attachment screws.
- f. Install brush block on mounting bracket with attachment hardware. Safety all bolts and check alignment of brushes to slip ring.

Reissued: 10/11/79

3A17

ACCESSORIES AND UTILITIES

14-14. INDIVIDUAL BRUSH REPLACEMENT.

- a. Remove brush retainer assembly per Paragraph 14-13.
- b. Mark receptacle flange and brush retainer block to permit reinstallation in the same position.
- c. Unsolder brush leads from receptacle pins and discard old brushes and springs.
- d. Install insulating tubing over brush leads and solder brush leads to receptacle pins; follow pin identification as shown on Figure 14-9.
- e. Assemble brushes and springs to brush guide block.
- f. Align marks and reinstall brush retainer as described in Paragraph 14-13.
- g. Check freedom of movement of each brush by pressing it into the brush guide block and allowing the spring to force it back out slowly.

CAUTION

Do not allow brush to snap back.

- h. Check resistance from each brush face to the respective receptacle pin with low range ohmmeter. Resistance must not exceed 0.013 ohms. Probe contacting brush should have an area of .062 square inch to provide an accurate measurement.
- i. Check insulation resistance between brushes and from brushes to receptacle housing with 500 VDC, 1000 megohm range "Megger" ("Meg" Type Insulation Tester, James G. Biddle Company, Plymouth Meeting, Penna., or equivalent). Resistance should not be less than 10 megohms for one minute.
- j. Install assembly on aircraft and check alignment. Safety all bolts.

14-15. ALIGNMENT OF NEW BRUSHES. Any time the brush block assembly is dismantled, the alignment at reinstallation must be checked as described in Paragraph 14-11 and Figure 14-7.

14-16. SLIP RINGS.

14-17. ALIGNMENT OF SLIP RING ASSEMBLY. Excessive slip ring run-out will result in severe arcing between the slip ring and brushes and cause rapid brush wear. If the run-out is not corrected, rapid deterioration of the slip ring and brush contact surfaces will result and lead to eventual failure of the Deicing System. Check the slip ring run-out with a dial indicator securely attached to the engine with the pointer resting on the slip ring. (Refer to Figure 14-6.) Rotate the propeller slowly noting the run-out indicated on the gauge. The total run-out must not exceed 0.005 inch \pm 0.0025 inch and 0.002 inch in any 4 inch interval of slip ring travel.

NOTE

Some error may be induced in the readings by pushing in or pulling out on the propeller. Care must be taken to exert a uniform push or pull.

Small amounts of run-out may be corrected by varying the torque on the slip ring mounting bolts (AN4-7A) between 40 to 100 inch-pounds to obtain the required flatness.

14-18. REPLACEMENT OF SLIP RING ASSEMBLIES. Slip ring assemblies that are open or shorted electrically, cracked or damaged structurally, or which have damaged surfaces beyond the scope of minor repair to clean up, should be replaced.

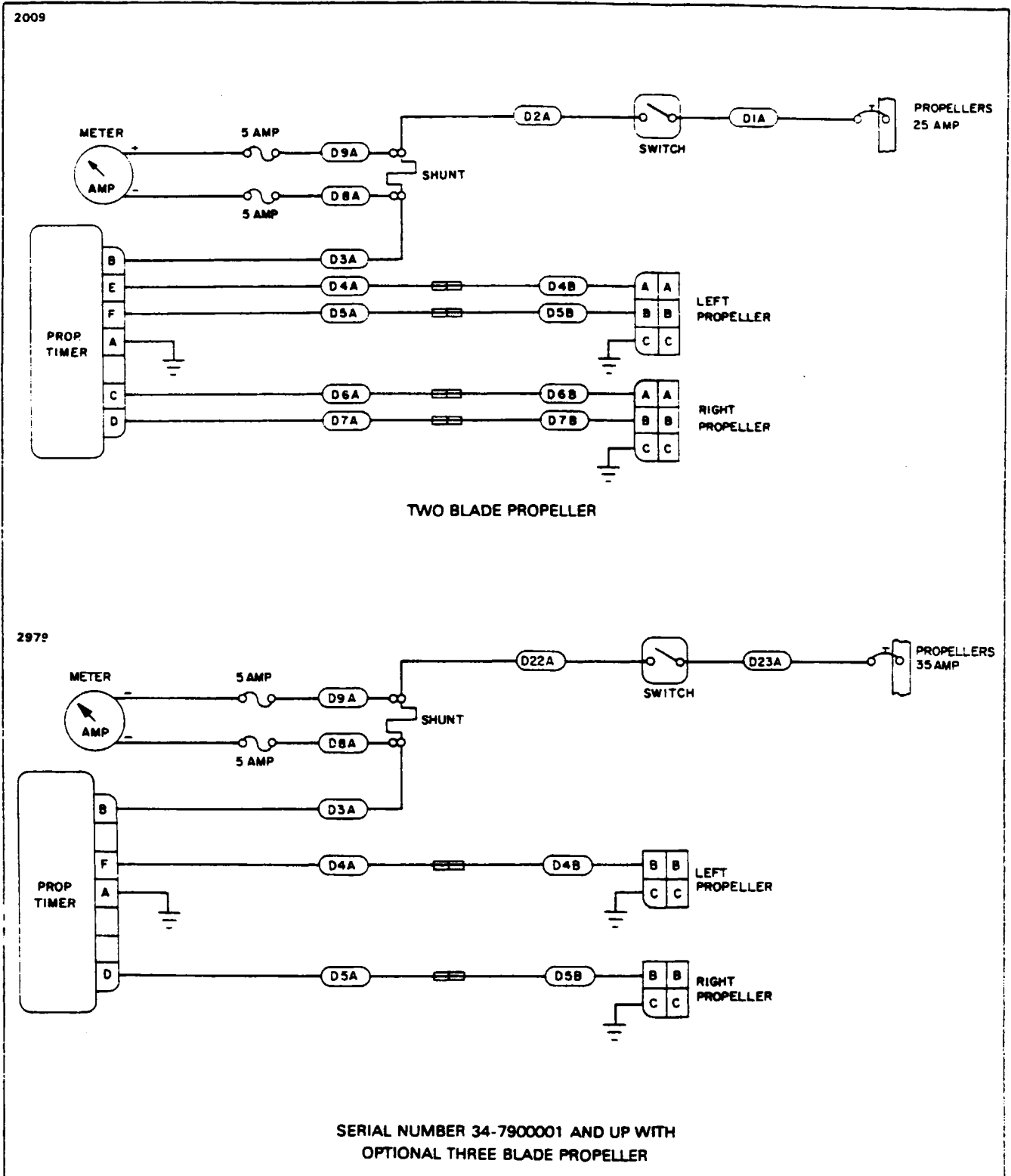

Figure 14-8. Wiring Schematic - Electrical Prop Deicing System

Revised: 8/10/80

3A19

ACCESSORIES AND UTILITIES

PIPER SENECA II SERVICE MANUAL

2030

1. BRUSH GUIDE BLOCK
2. BRUSHES
3. RECEPTACLE
4. SPRING
5. BRUSH RETAINER BLOCK
6. TUBING

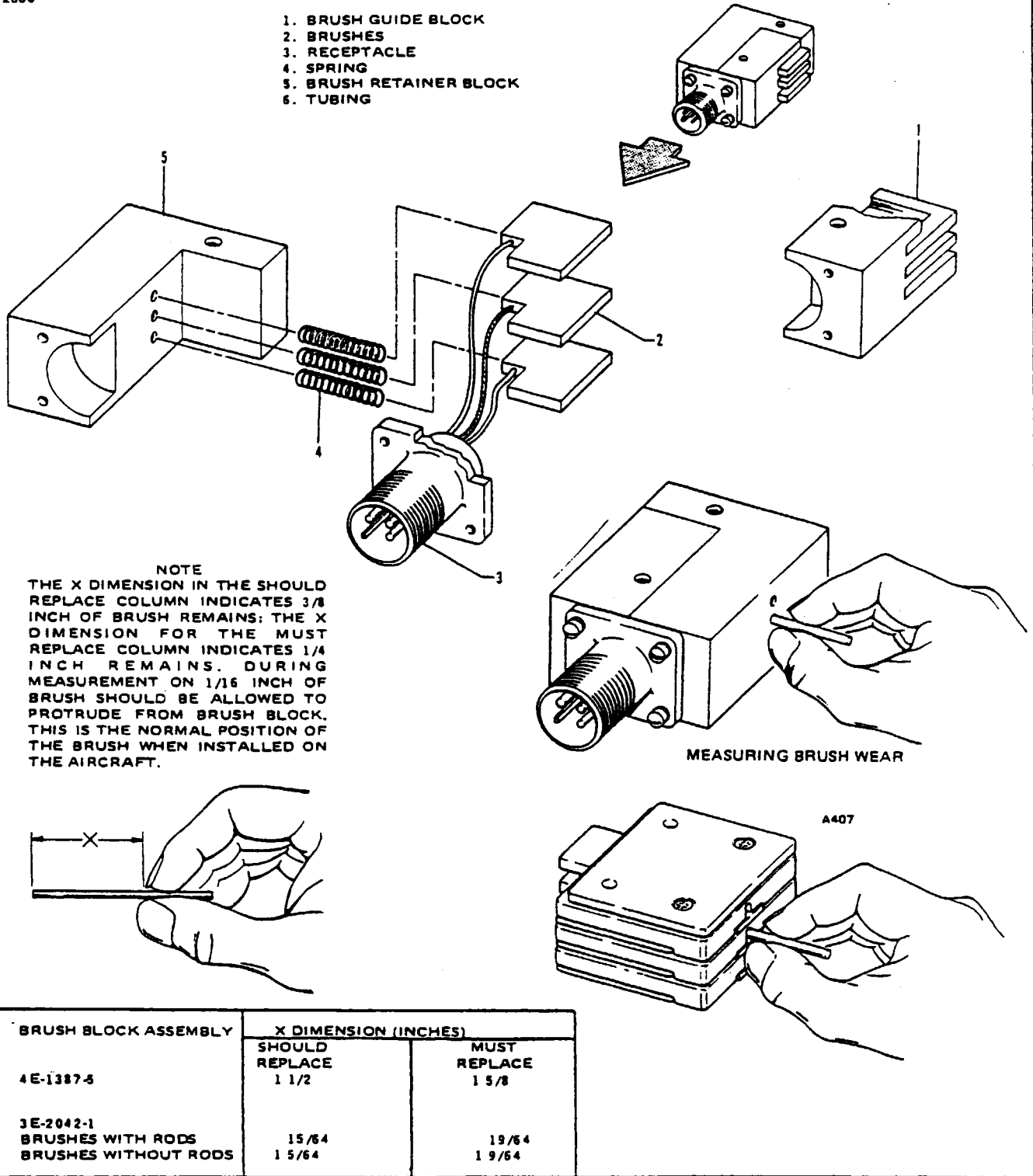

Figure 14-9. Brush Block Assembly

14-18a. REPLACEMENT OF BRUSH BLOCK WITH MODULAR BRUSH ASSEMBLIES. Modular brush block assembly part number 3E2042-1, is a direct replacement for brush block assemblies part numbers 4E1837-3 and 4E1837-5. Instructions concerning replacement of brush block assemblies with modular brush assemblies are given in B.F. Goodrich Service Bulletin E-77-54.

14-18b. BRUSH MODULE REPLACEMENT. Brush modules should be replaced when .375 inch of brush material remains; brush modules must be replaced when .250 inch remains. Measure the brushes as shown in Figure 14-9. Replace brush modules as follows:

NOTE

Brushes are not offered individually as replacements; When a brush wears out, the module containing it should be replaced.

- a. Remove the modular brush assembly from the aircraft, by removing the attachment hardware, and disconnect the engine wire harness.
- b. Remove assembly screws and separate modules and spacers.

NOTE

The part number of each module is etched into the surface of the plastic housing; replace with the same part number module.

- c. Restack modules and spacers as shown in Figure 14-10b. If there is interference between adjacent ring terminals, reorient center module as shown in Figure 14-10a.

NOTE

Ascertain flat washer is positioned between star washer and housing.

- d. Reconnect aircraft wire harness and insure adjacent ring terminals are not touching.
- e. Install assembly on aircraft and check adjustment.

14-19. DEICER BLADES.

14-20. RESISTANCE CHECK OF DEICER BLADE. To determine incorrect resistance, short or open at the brush-to-slip ring contact, disconnect harness at the timer and use low range ohmmeter to read resistance from each deicer circuit lead (Pins C,D, E and F of harness plug) to ground; it should read .47 to .58. If this reading is not obtained, disconnect the deicer lead harness to measure heater resistances individually. Individual heater should be 0.95 to 1.15. If first check is off limits but second check is satisfactory, trouble is probably in the brush-to-slip ring area; if the second check is off limits, the deicer is damaged and must be replaced.

14-21. REPLACEMENT. If tests show the blade deicer to have an open circuit, to be the wrong resistance or to be visibly damaged beyond repair as outlined in Paragraph 14-11 of this section, replace the deicer as directed in Paragraphs 14-24 thru 14-30.

A486

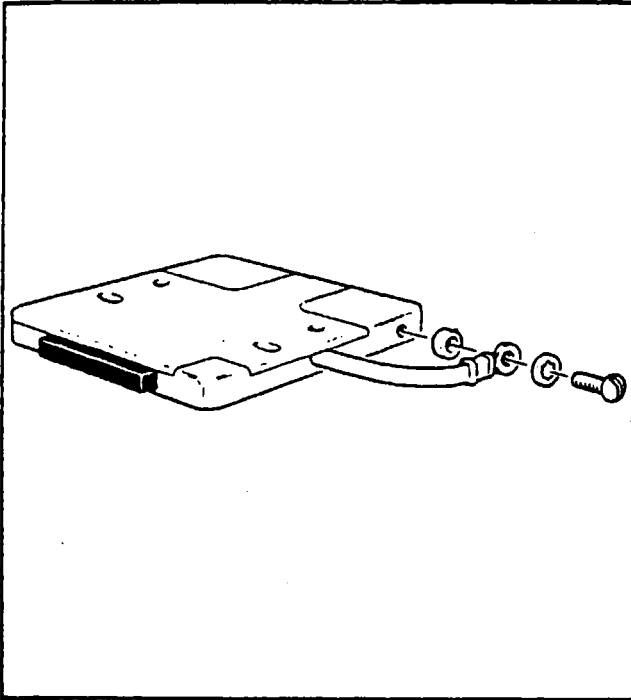

Figure 14-10. Brush Module Assembly 3E2011.

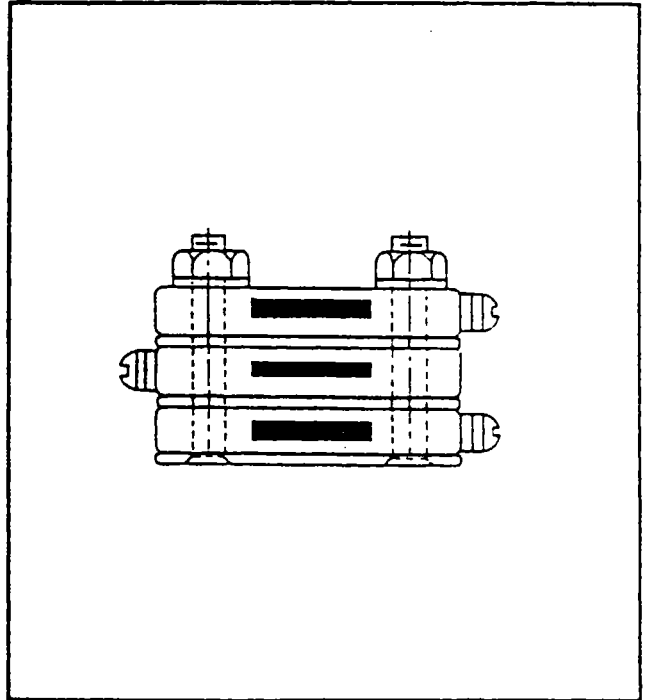

Figure 14-10a. Alternate Module Stacking Arrangement.

INTENTIONALLY LEFT BLANK

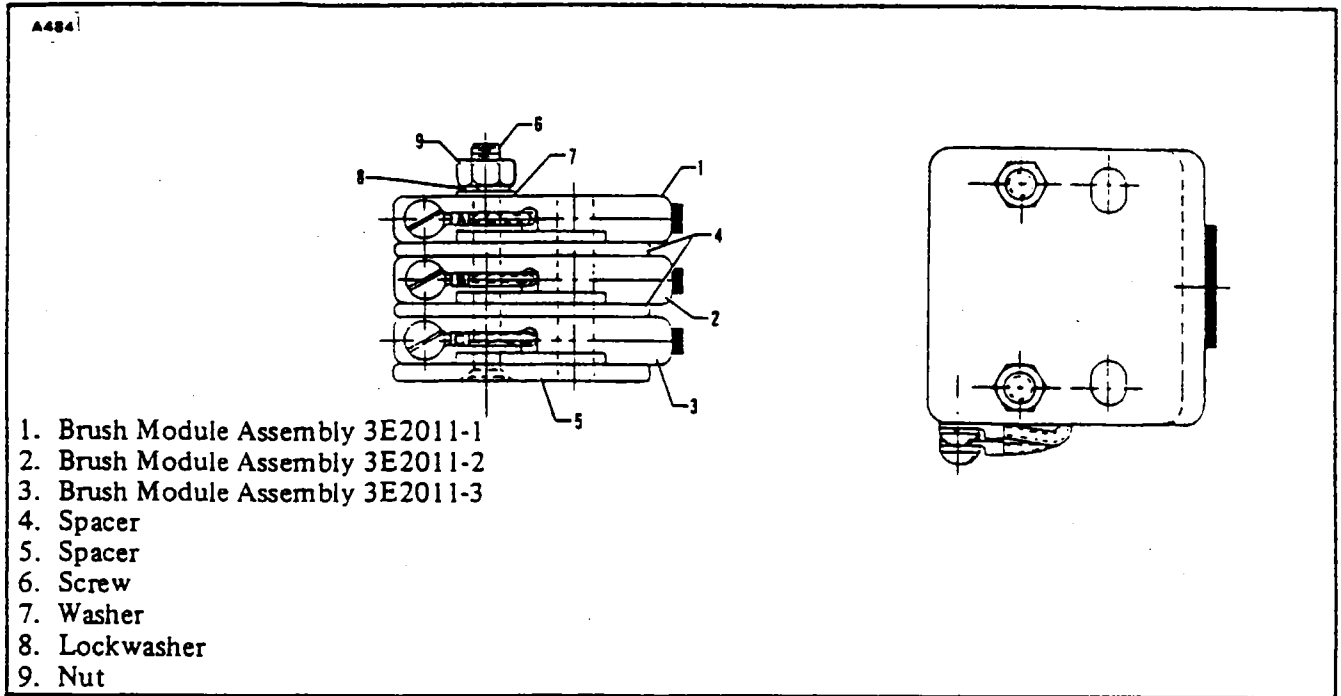

Figure 14-10b. Modular Brush Assembly 3E2042-1 (2 Bladed Prop)

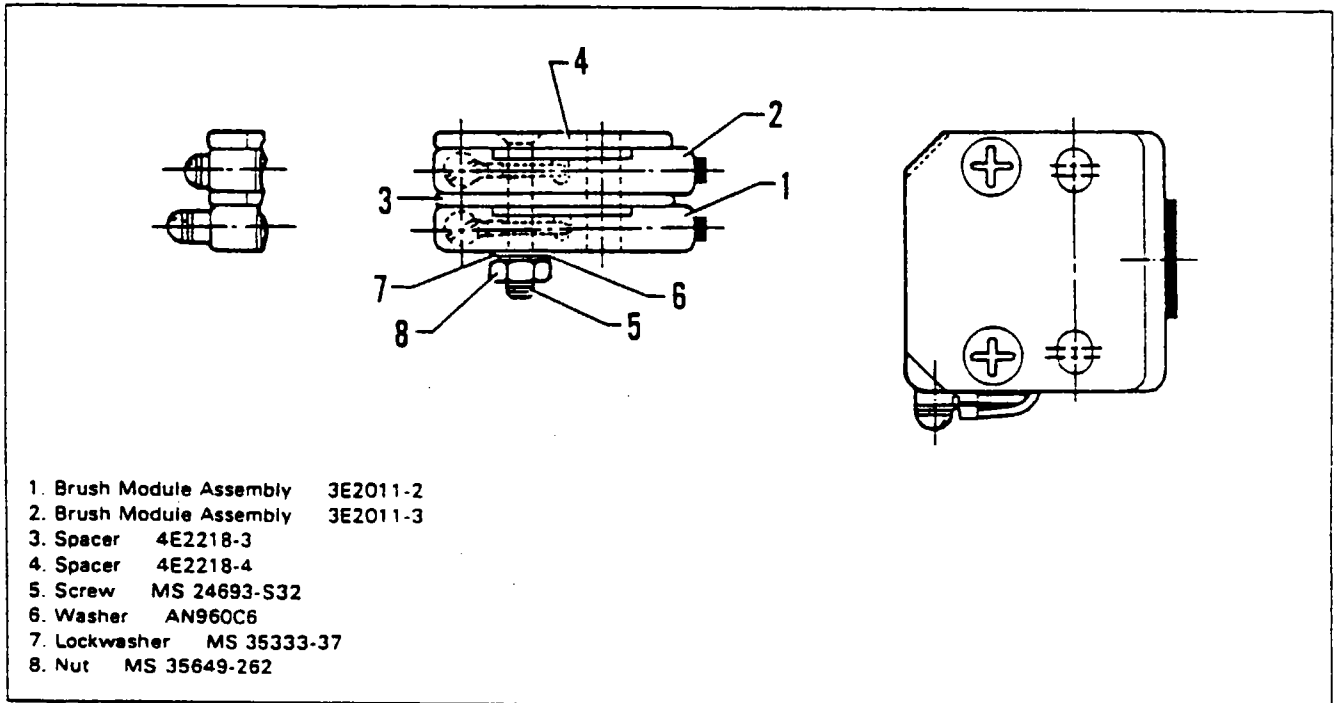

Figure 14-10c. Modular Brush Assembly 3E2062-2 (3 Bladed Prop)

Revised: 3/16/81

ACCESSORIES AND UTILITIES

3A23

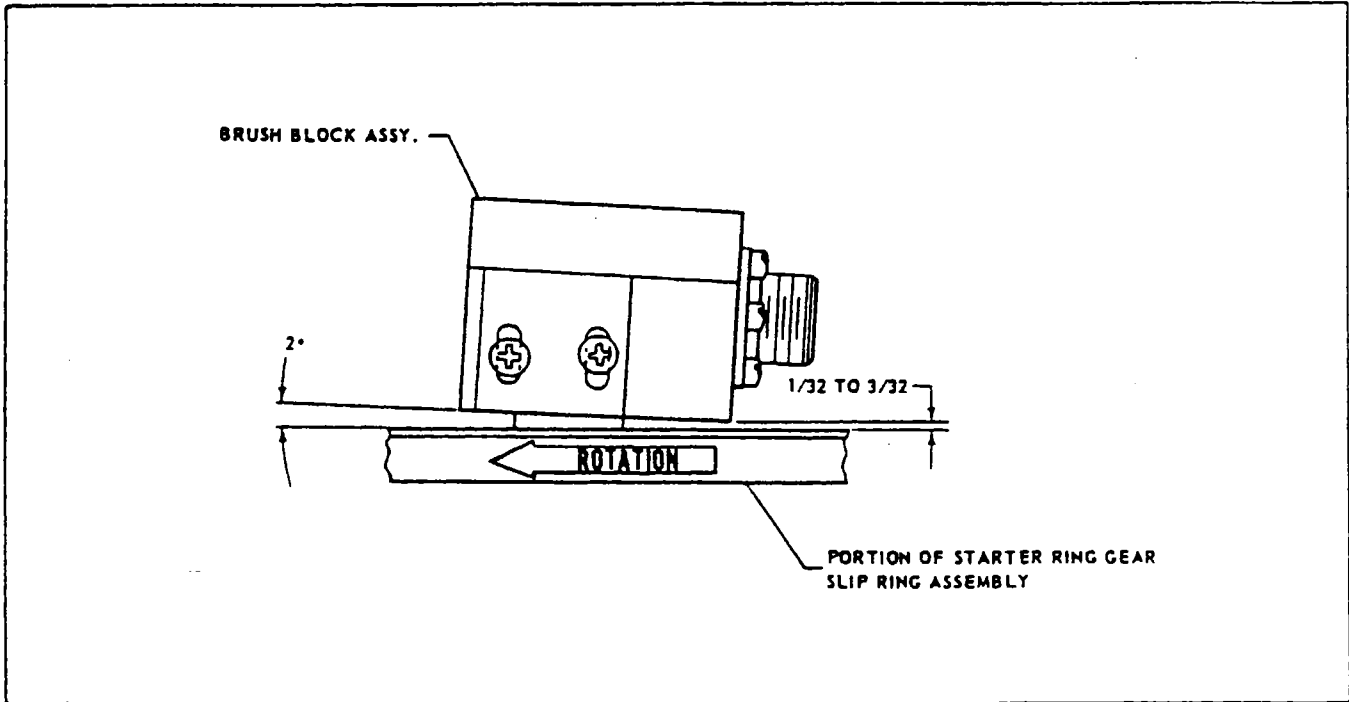

Figure 14-10d. Angle of Contact Brushes to Slip Rings

2031

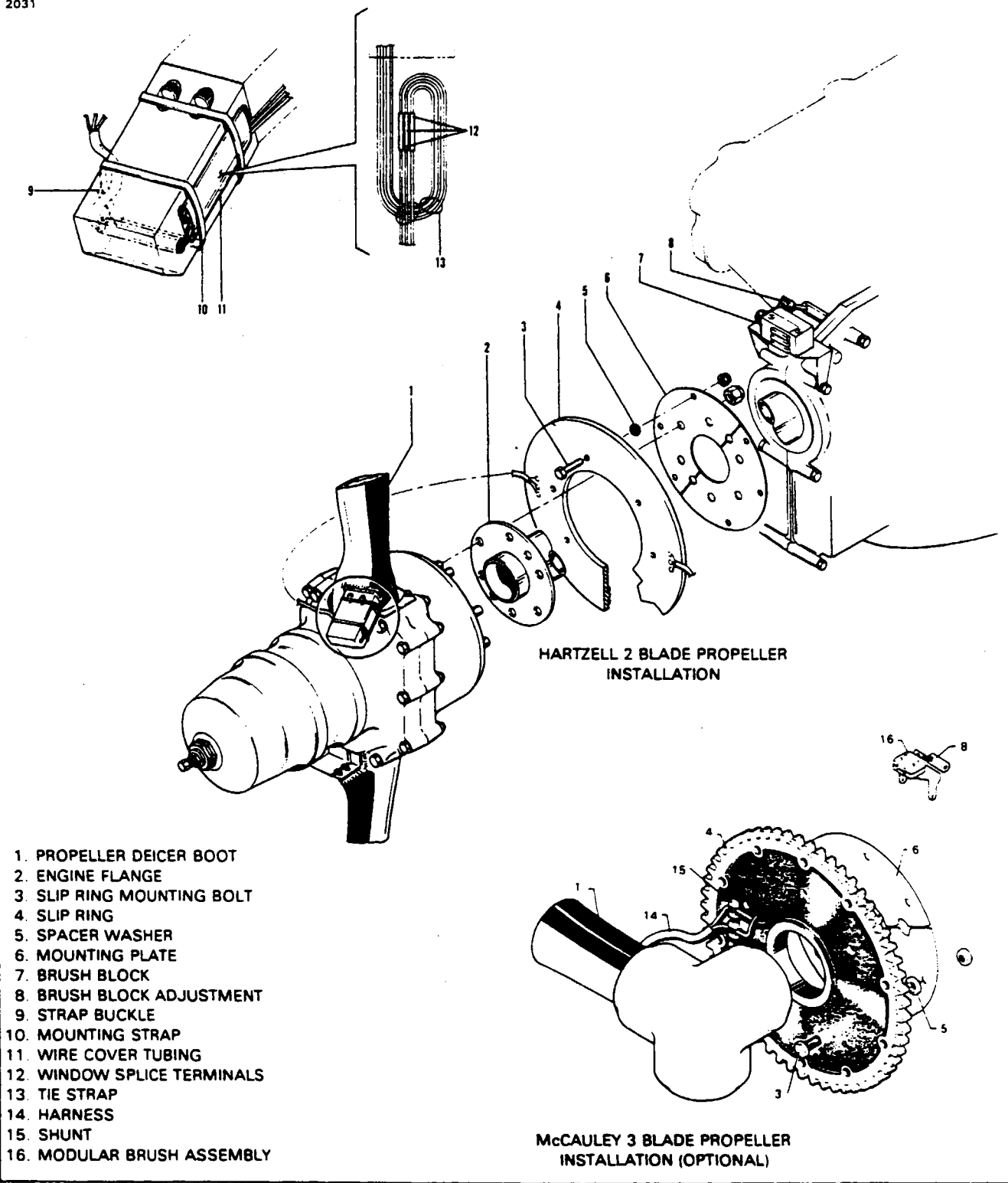

Figure 14-11. Propeller Deicer Installation

Reissued: 10/11/79

ACCESSORIES AND UTILITIES

3B1

14-22. REMOVAL OF DEICER.

- a. Disconnect terminals of propeller deicer from studs on the spinner bulkhead.
- b. Use MEK or Toluol to soften the adhesion line between the deicer and the propeller blade.

CAUTION

Do not allow solvents to leak into propeller hubs and cause damage to seals.

- c. Starting at one corner of the deicer, loosen enough of the deicer to grasp in the jaws of vise grip pliers or similar tool.
- d. Apply a steady pull on the deicer to pull it off the propeller surface. Continue using MEK or Toluol to soften the adhesion lines. Unless the deicer being removed is damaged and is to be scrapped, cushion the jaws of any pulling tool used to prevent damage to the deicer surface. Remove very slowly and carefully. If deicer has failed and is to be returned under request for warranty, extreme care should be exercised so that no additional damage is incurred to the deicer during and after removal.
- e. Remove residual cement from blade. Use Turco No. 3 or equivalent to help with dried cements.

14-23. BLADE PREPARATION.

- a. Mark and cut from masking tape a pattern the size of the propeller deicer. (Refer to Figure 14-12.)
- b. Place a mark at the hub end of the blade in line with the blade leading edge. The location for this mark can be determined by sighting along the leading edge. Starting at the hub (see Note below), center the pattern on this mark and stick the pattern to the leading edge. Mark the position of the deicer harness.

NOTE

All deicers on a single propeller must be located the same distance from the hub for rotational balance.

- c. Remove the pattern and remove any paint in the marked off area. Clean down to bare metal. Next, clean the area thoroughly with MEK or acetone. For final cleaning, wipe the solvent off quickly with a clean, dry lint-free cloth to avoid leaving a film.

CAUTION

Cleanliness of metal and rubber parts cannot be too highly stressed. Only perfectly clean surfaces will assure maximum adhesion.

- d. Using a pencil or pen, mark a centerline at the hub of the propeller blade and on the tape at the outboard edge of the masked area.

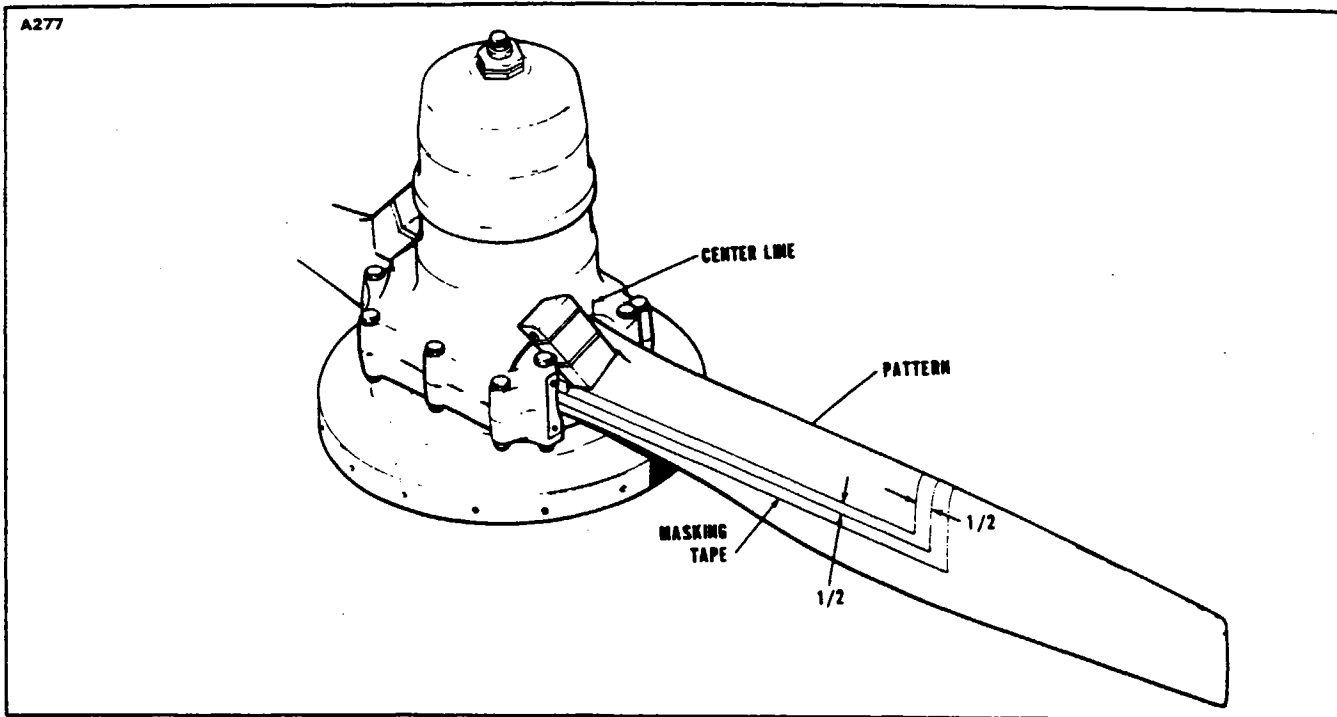

Figure 14-12. Installation of Deicer Boot

TABLE XIV-I. REQUIRED MATERIALS FOR REPAIR OF PROPELLER DEICER

The materials and tools listed below are commercially available and are not supplied by B.F. Goodrich in kit form:

- Cement 1300L or EC1403 (Minnesota Mining & Mfg. Co.)
- Sealer 82-076-1 and -2 (B.F. Goodrich, Akron, Ohio, or Sealer C-19861, C-21871 and C-16176 (Lowe Bros., Dayton, Ohio)
- Cleaning Solvent - MEK (MethylEthylKetone) or Acetone
- Tackifying Solvent - Toluol or MEK (See Note)
- Cleaning Cloth - any clean, lint-free cloth
- 1 inch paint brushes
- 2 inch rubber hand roller
- 1/4 inch hand stitcher
- Masking tape

NOTE

MEK may be used instead of Toluol to tackify cement, but it provides approximately 10 seconds working time for deicer applications. whereas Toluol provides approximately 40 seconds working time.

14-24. CEMENT APPLICATION.

- a. Using a silver pencil, mark a centerline on the glossy side of the deicer.
- b. Moisten a clean cloth with MEK or acetone and clean the unglazed surface of the deicer, changing cloth frequently to avoid contamination of the clean area.
- c. Thoroughly mix the 1300L cement. Apply one even brush coat of cement to the unglazed back surface of the deicer. Cement one inch of the deicer lead strap. Allow to air dry for a minimum of one hour at 40° F or above, when the relative humidity is less than 75%. If the humidity is 75% to 90%, allow two hours drying time. Do not apply cement if the relative humidity is higher than 90%. After allowing the proper amount of drying time, apply a second even brush coat of 1300L cement.

NOTE

If curling of the deicer edges is a problem, apply masking tape to the edges of the glazed side before applying cement to the unglazed side. Remove the tape before starting to install the deicer.

- d. Apply an even brush coat of 1300L cement on the cleaned surface of the propeller blade, immediately after the second coat of cement has been applied to the deicer. This timing is important for the cement on both surfaces to reach the tack stage at the same time.

14-25. INSTALLATION OF DEICER AND REQUIRED MATERIALS. It is imperative that the following instructions be followed exactly to insure maximum adhesion to the propeller blades:

- a. When the cement coats are tacky (slightly sticky to the touch-like masking tape), dry on both the propeller surface and deicer surface, position deicer on blade leading edge. Start at hub end, using centerlines as a guide. (Refer to Figure 14-12.)
- b. Make sure that the harness will fall in the previously marked position.
- c. Working outward toward the tip, tack the deicer centerline to the leading edge of the propeller blade.
- d. Use the tackifying solvent as necessary. If deicer is allowed to get off course, pull up with a quick motion and re-apply deicer.
- e. If cement is removed from either surface, completely remove the deicer and re-apply cement per Paragraph 14-24.
- f. When the deicer is correctly positioned, roll firmly along the centerline with a rubber roller. (Refer to Figure 14-13.)
- g. Gradually tilt the rubber roller and carefully work the deicer over either side of the blade contour to avoid trapping air. Roll outwardly from centerline to edges. Be especially careful to work out excess material at outboard edge of deicer before other edges are completely rolled down. If excess material at edges tends to pucker, work out puckers smoothly and carefully with fingers.
- h. Roll the tapered edges, especially inboard edge of the deicer with the metal stitcher.

CAUTION

To avoid damage to deicer resistance wires, do not use metal stitcher on body of deicer. Area where metal stitcher is permitted not to exceed 3/16" along deicer edge.

14-26. PREPARATION AND APPLICATION OF SEALER. Deicers loosened due to destruction of adhesive bond by lubricants do not respond well to recementing. Therefore, removal, cleaning, and reinstallation of the deicers are recommended. (Refer to Paragraphs 14-22 and 14-25.)

- a. Clean an area .500 of an inch wide around the circumference of the deicer down to the bare metal. Use MEK or Acetone and clean thoroughly.
- b. Clean outer .500 of an inch of all deicer edges and back under deicer about .250 of an inch on all sides past loosened areas with MEK or Acetone. For final cleaning, quickly wipe off solvent with a clean, dry lint-free cloth to avoid leaving a film.
- c. Recement loosened areas of deicers in accordance with Paragraph 14-24.
- d. Mix the filler, sealer, or paint thoroughly and in the proper proportions by weight, as given in Table XIV-II.
- e. Locate masking tape approximately .125 of an inch beyond the cemented area around the deicer to permit filler material to contact bare metal.
- f. Apply one even coat of filler to area around the inboard end and sides of the deicer. (Refer to Figure 14-14.) Immediately remove the masking tape and allow the filler to dry for six hours.
- g. Apply masking tape about .125 of an inch beyond filler or .250 of an inch beyond cemented area when no filler is used, to permit sealer to contact bare metal. Apply one even brush coat of sealer to the area around the deicer. (Refer to Figure 14-14.) Remove masking tape immediately and allow sealer to dry. Allow 12 hours cement curing time before starting engine, allow 24 hours cement curing time before operating the deicers.

TABLE XIV-II. MIXING OF MATERIALS

Material	Manufacturer & No.	Mixing Proportions
Filler	3M EC1031 and EC801	Twelve parts EC1031 with one hundred parts EC801.
Sealer	BFG 82-076-1 & -2 or Lowe Brothers V66V27, F63B8, & R7K69	Twelve parts -1 with one part -2. One part V66V27 with seven parts F63B8 (and up to two and two-thirds parts R7K69 thinner as needed).

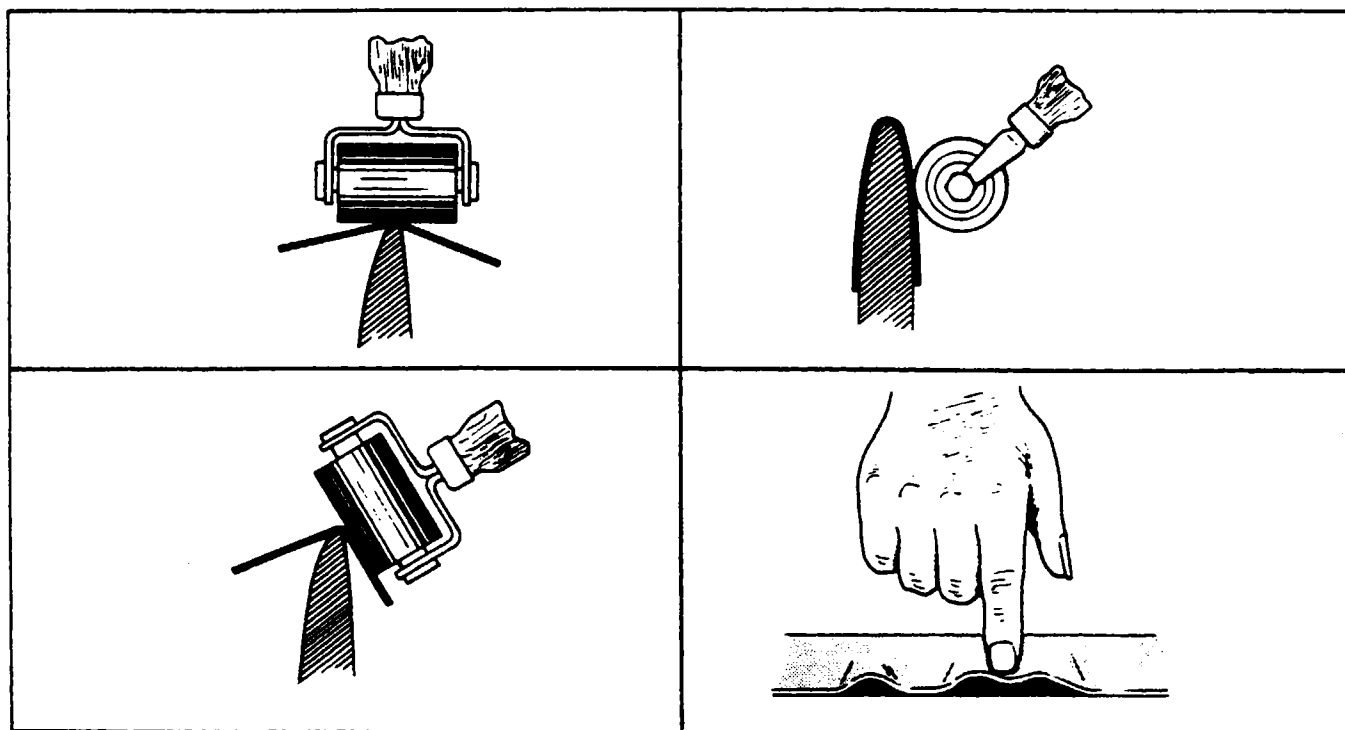

Figure 14-13. Wrinkled Deicers

14-27. **WRINKLED DEICERS.** (Refer to Figure 14-13.) If edge of deicer is found wrinkled or loose, try recementing. Use MEK or Toluol to loosen the bond for an additional 1/4 inch beyond the loose or wrinkled area. Apply one coat of 1300L cement to the deicer and propeller bonding surfaces and allow to air dry for one hour. Then apply a second coat of 1300L cement to both the deicer and bonding surface. Allow to dry. Retackify with MEK or Acetone and press with fingers to work out wrinkles or to secure loose edges. If material has stretched and will not cement flat, replace the deicer.

14-28. **ELECTRICAL CHECK.**

- a. Check the electrical resistance of each of the two elements within the deicer. (Refer to Schematic, Figure 14-8 and Resistance Readings.) (Refer to Table XIV-III.)
- b. Check for intermittent open circuits by tensioning the deicer strap slightly while measuring the resistance. Also, press lightly on the deicer surface in the area adjacent to the harness. Resistance must not vary.
- c. Identification of the circuits within the element may be confirmed by referring to the resistance values and schematic diagram. Proper identification is necessary in order to make the system cycle properly and to obtain the correct amperage values during system operation. Minimum and maximum ohms between common ground and either of the other terminals is .095 to 1.15.

NOTE

These resistances apply only to deicers that are not connected to terminal studs.

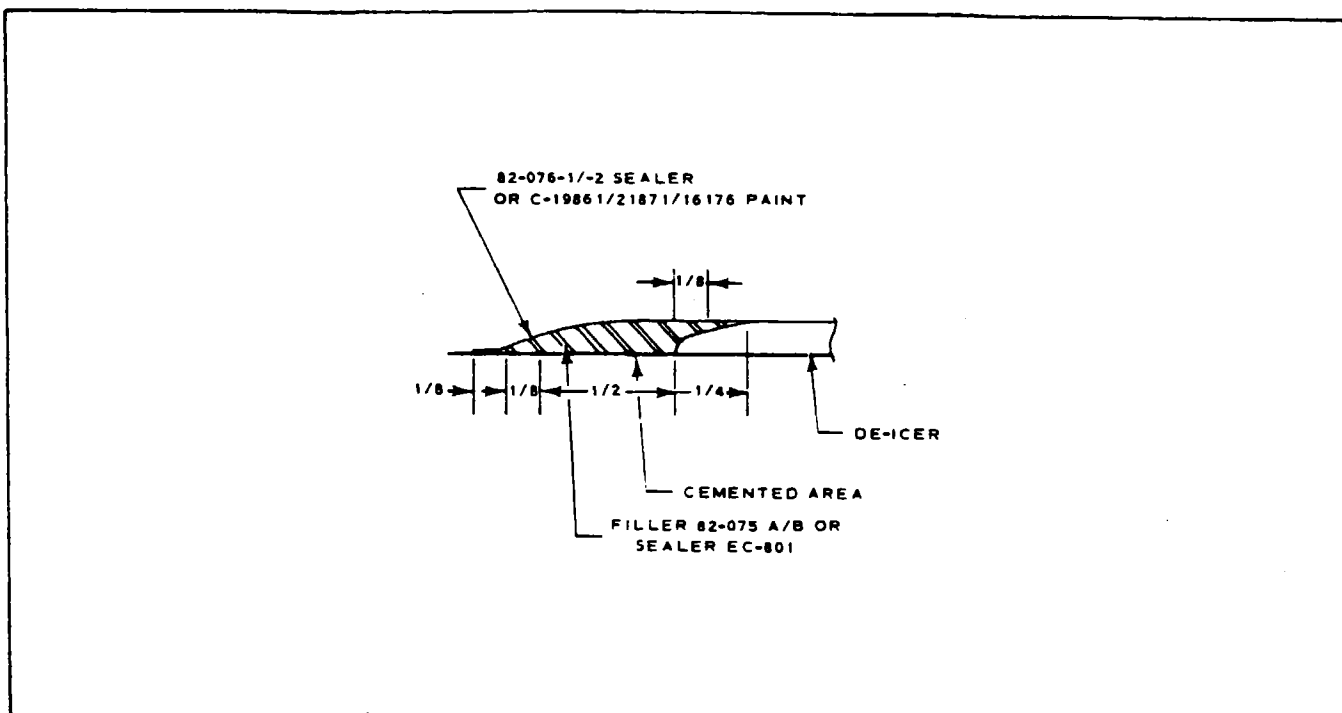

Figure 14-14. Sealer Application (Boot)

TABLE XIV-III. ELECTRICAL RESISTANCE

Resistance Check	Max.	Min.
1 Blade each Element	1.15	0.95
2 Blades in Parallel	0.58	0.47

14-29. **INSTALLATION OF DEICER WIRING HARNESS.** (Refer to Figure 14-11.) The deicer wiring harness must be installed to the propeller counterweight as follows:

- a. Place the wires in a configuration as shown in Figure 14-11.
- b. Slide the 5/8 inch I.D. tubing over the wire configuration.
- c. Feed the wire harness through the hole in the counterweight as shown in Figure 14-11.
- d. Position the wire bundle on the counterweight and install tie straps with the buckle on the side of the counterweight as shown in Figure 14-11.
- e. Route the wire harness and protective tubing under the first tie strap and tighten both tie straps.
- f. Install terminals of harness to screws on spinner bulkhead and tighten lead clip over harness.

14-30. **BALANCING.** To assure balance of the propeller assembly, the original balancing weights or their equivalents must be reinstalled. The weights must be left in the original position on the propeller hub. The restrainer and weights should not interfere with any part of the propeller assembly under any condition. If for any reason balance weights were removed, reinstall safety wire on screws. The deicer wire harness must be installed on the propeller as described in Paragraph 14-29.

14-31. **FINAL ELECTRIC CHECK.**

- a. Make certain that all terminals are tight. Do not over torque.
- b. Check the electrical resistance between the deicer terminals or between the slip rings. The reading should be per Table XIV-III.

14-32. **OTHER COMPONENTS.** Do not attempt internal repairs of the timer, ammeter or switch. If inoperative, these components must be replaced with one of the correct part numbers. For any other repair or maintenance problems not covered in this manual, inquire at Aerospace and Defense Products Division of the B.F. Goodrich Company, Akron, Ohio 44318.

14-33. **TIMER TEST.** Field experience indicates that too often the timer is considered at fault when the true trouble lies elsewhere. Before removing a timer as defective, perform this test:

- a. Disconnect wire harness at timer and with deicer switch ON, check voltage from Pin B of harness plug to ground. If system voltage is not present, the fault is not in the timer. If system voltage is present at Pin B, check ground circuit using ohmmeter from Pin G to ground. If no circuit is shown, the fault is in ground lead, not in timer. If ground connection is open, the timer step switch will not change position.
- b. When power and ground circuits have been checked, connect a jumper wire from Pin B of harness to B contact of timer socket to power timer. Connect a jumper wire from Pin G of harness to G contact of timer socket to complete the power circuit. Now use voltmeter from ground to the timer socket and check that timer is cycling to deliver system voltage to C, D, E, and F contacts in that order. (The starting point is not important but sequence must be as given.) Each of these four contacts must deliver voltage for approximately 34 seconds, in turn, and there must be zero voltage on the three contacts not energized.
- c. If the timer meets these requirements, it is not the cause of the trouble. If it fails to perform as indicated, the trouble does lie in the timer and it should be replaced.

TABLE XIV-IV. TROUBLESHOOTING CHART
(PROPELLER DEICER SYSTEM)

Trouble	Cause	Remedy
<p>Ammeter shows zero current. (All 4 phases of the 2 minute cycle.)</p>	<p>Tripped circuit breaker switch.</p> <p>No power from airplane.</p> <p>Circuit breaker switch faulty.</p> <p>Ammeter faulty. (If some or all deicers heat with ammeter at zero, replace the ammeter.)</p> <p>Open ammeter to timer.</p>	<p>Locate and correct short before setting circuit breaker.</p> <p>If no voltage into switch, locate and correct open.</p> <p>If no voltage at switch output with voltage at switch input, replace the switch. If voltage is satisfactory at switch output, go to next step.</p> <p>Test for voltage up to and out of ammeter. If low or zero output and input satisfactory, replace ammeter. If no voltage to ammeter, locate and fix open between switch and ammeter.</p> <p>Disconnect harness at timer and check voltage at Pin B (of harness) to ground. If none, locate and correct open.</p>

PIPER SENECA II SERVICE MANUAL

TABLE XIV-IV. TROUBLESHOOTING CHART
(PROPELLER DEICER SYSTEM) (cont.)

Trouble	Cause	Remedy
<p>Ammeter shows normal current part of cycle, zero current rest of cycle.</p>	<p>Open in wiring between timer and brush block assembly.</p> <p>Open between brush block assembly and deicer lead straps.</p> <p>No ground circuit, one engine.</p>	<p>Use heat test to find deicers not heating and test for voltage on that contact of wire harness plug. (At brush block assembly.) If zero over 2 minutes, locate and fix open in wiring from timer to wire harness plug.</p> <p>If there is voltage to brush block wire harness plug, try voltage at junction to deicer lead and slip ring lead. If no voltage, find and correct open in wiring within brush block or no contact of brush to slip ring.</p> <p>If voltage is found at deicer leads, locate and fix open from deicer to ground.</p>
<p>Ammeter shows normal current part of cycle, low current rest of cycle.</p>	<p>Inner and outer deicers heating same phase.</p> <p>Open in deicer or slip ring leads.</p>	<p>Locate and repair incorrect connections.</p> <p>Disconnect deicer harness to check heater resistance as in Paragraph 14-28. If satisfactory, locate and fix open in slip ring leads.</p>

TABLE XIV-IV. TROUBLESHOOTING CHART
(PROPELLER DEICER SYSTEM) (cont.)

Trouble	Cause	Remedy
<p>Ammeter shows normal current part of cycle, low current rest of cycle. (cont.)</p>	<p>High resistance in circuit with low current.</p>	<p>If not in contact of brush to slip ring (including ground brush), trace wiring to deicer and to timer to fix partially broken wire, loose or corroded connection.</p>
<p>Ammeter shows low current over entire cycle.</p>	<p>Aircraft voltage low. Ammeter faulty.</p>	<p>Check voltage into switch. Test for voltage up to and out of ammeter. If low or zero output and input satisfactory, replace ammeter. If no voltage to ammeter, locate and fix open between switch and ammeter.</p>
<p>Ammeter shows excess current over entire cycle.</p>	<p>High resistance up to timer.</p>	<p>Check for partially broken wire, loose or corroded connection in wiring from aircraft supply to timer input.</p>
<p>Ammeter shows excess current over entire cycle.</p>	<p>Ammeter faulty.</p>	<p>Test for voltage up to and out of ammeter. If low or zero output and input satisfactory, replace ammeter. If no voltage to ammeter, locate and fix open between switch and ammeter.</p>

TABLE XIV-IV. TROUBLESHOOTING CHART
(PROPELLER DEICER SYSTEM) (cont.)

Trouble	Cause	Remedy
<p>Ammeter shows excess current over entire cycle. (cont.)</p> <p>Ammeter shows normal current part of cycle, excess current rest of cycle.</p>	<p>Ground between ammeter and timer.</p>	<p>Disconnect harness at timer and with ohmmeter check from Pin B (of harness) to ground. If ground is indicated, locate and correct.</p>
	<p>Ground between timer and brush block.</p>	<p>Disconnect leads at brush block and with ohmmeter check from power leads to ground. If ground is indicated, locate and correct.</p>
	<p>Ground between brush block and deicers. (Excluding ground brush circuit.)</p>	<p>If no short exists at brush-slip ring contact, check for ground from slip ring lead to propeller assembly while flexing slip ring and deicer leads. If a ground is indicated, locate and correct.</p>
	<p>Short between two adjacent circuits.</p>	<p>Check for cuts or low resistance between circuits. If any, locate and correct.</p>
<p>Timer faulty.</p>	<p>Test timer as in Paragraph 14-33.</p>	

TABLE XIV-IV. TROUBLESHOOTING CHART
(PROPELLER DEICER SYSTEM) (cont.)

Trouble	Cause	Remedy
<p>Ammeter does not "flick" approximately every 34 seconds.</p>	<p>Timer ground open.</p>	<p>Disconnect harness at timer and check with ohmmeter from Pin G (of harness) to ground. If no circuit, fix open per schematic diagram.</p>
<p>Ammeter flicks between 34 second phase periods.</p>	<p>Timer contacts are welded (caused by short circuit in system).</p> <p>Loose connection between aircraft power supply and timer input.</p> <p>Loose or poor connection timer to deicers.</p>	<p>Test timer as in Paragraph 14-33. If timer does not cycle with voltage at Pin B, replace timer but be sure short causing original failure has been located and corrected.</p> <p>If trouble occurs over entire cycle, trace wiring from power source to timer input to locate and tighten loose connection.</p> <p>If trouble occurs in part of cycle, find which deicers are affected and check for rough or dirty slip rings causing brush to "skip." If not this, trace circuits to locate and fix loose or poor connection. (If all deicers on one propeller are affected, check the ground circuit.) Flex deicer straps for break in deicer straps.</p>

PIPER SENECA II SERVICE MANUAL

TABLE XIV-IV. TROUBLESHOOTING CHART
(PROPELLER DEICER SYSTEM) (cont.)

Trouble	Cause	Remedy
Ammeter flicks between 34 second phase periods. (cont.)	Timer cycles erratically.	Test timer as in Paragraph 14-33.
Radio noise or interference with deicers on.	Brushes "arcing."	Check brush alignment as shown in Figures 14-7 and 14-10. Look for rough or dirty slip rings. If this is the cause, clean machine or replace slip ring assembly, as required. Check slip ring alignment. (Refer to Paragraph 14-17.)
	Loose connection.	Refer to "Ammeter flicks between 34 second phase period."
	Switch faulty.	Try jumper wire across switch. If radio noise disappears, replace the switch.
	Wiring located within 8 inches of radio equipment wiring.	Relocate at least 8 inches away from input wiring to radio equipment.
Cycling sequence not correct.	Crossed connections.	Check system wiring circuit diagram for improper connections. (Refer to Figure 14-8.)
Rapid brush wear or frequent breakage.	Brush block out of alignment.	Check brush alignment. (Refer to Paragraph 14-15.)
	Slip ring wobbles.	Check slip ring alignment with dial indicator as shown in Figure 14-6.

1981

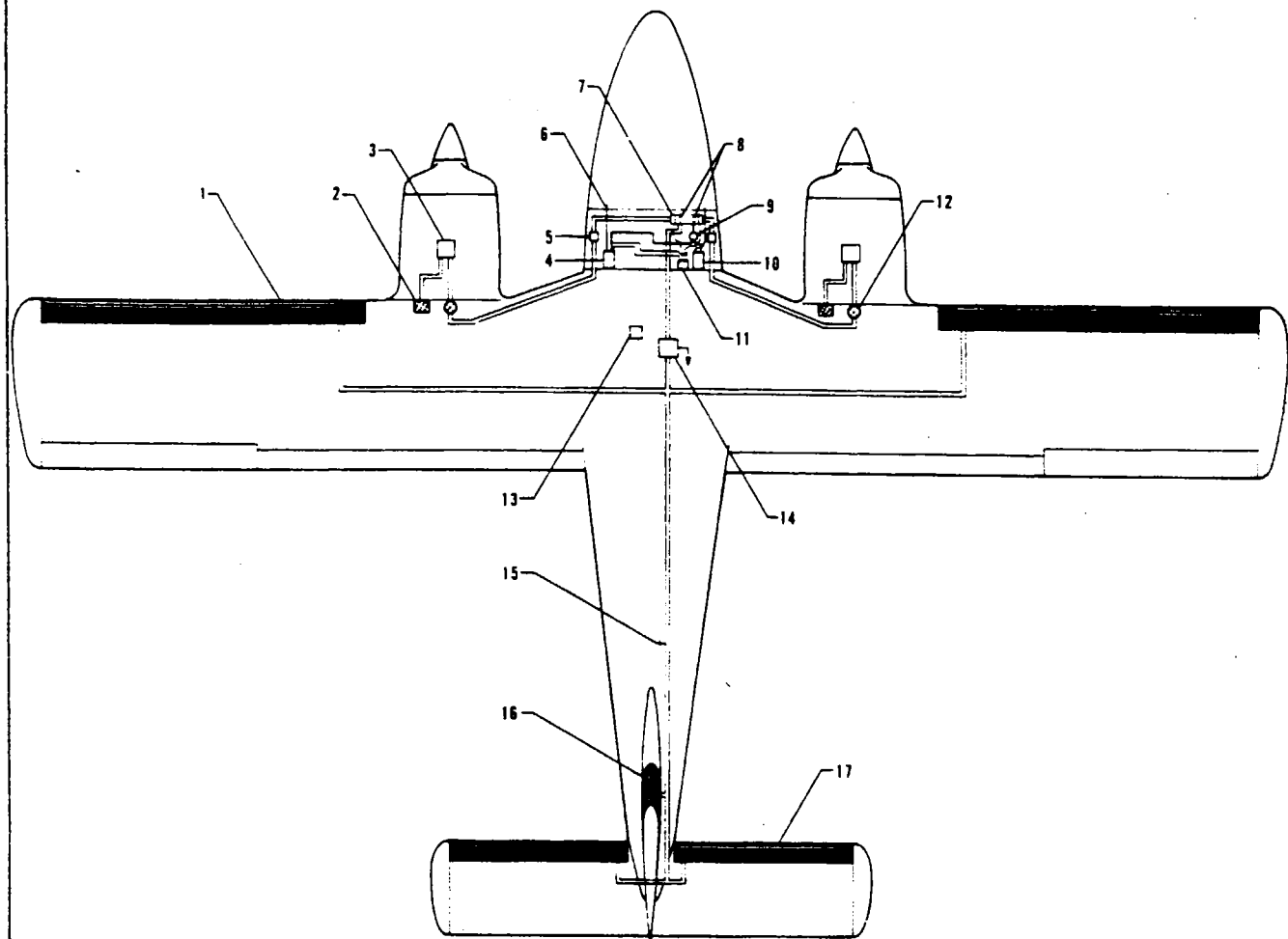

1. WING DEICER BOOTS
2. AIR FILTER
3. AIR PUMP
4. PILOT GYRO INSTRUMENT
5. IN LINE FILTER
6. OVERBOARD
7. MANIFOLD
8. CHECK VALVES
9. REGULATOR
10. COPILOT GYRO INSTRUMENT
11. PRESSURE GAUGE
12. DUAL STAGE PRESSURE REGULATING VALVE
13. TIME MODULE
14. EJECTOR FLOW CONTROL VALVE
15. PRESSURE SWITCH
16. TAIL DEICER BOOTS
17. STABILATOR DEICER BOOTS

Figure 14-15. Pneumatic Deicer System Installation
(Serial Nos. up to 34-8070144)

Revised: 8/10/80

3B15

ACCESSORIES AND UTILITIES

PIPER SENECA II SERVICE MANUAL

3022

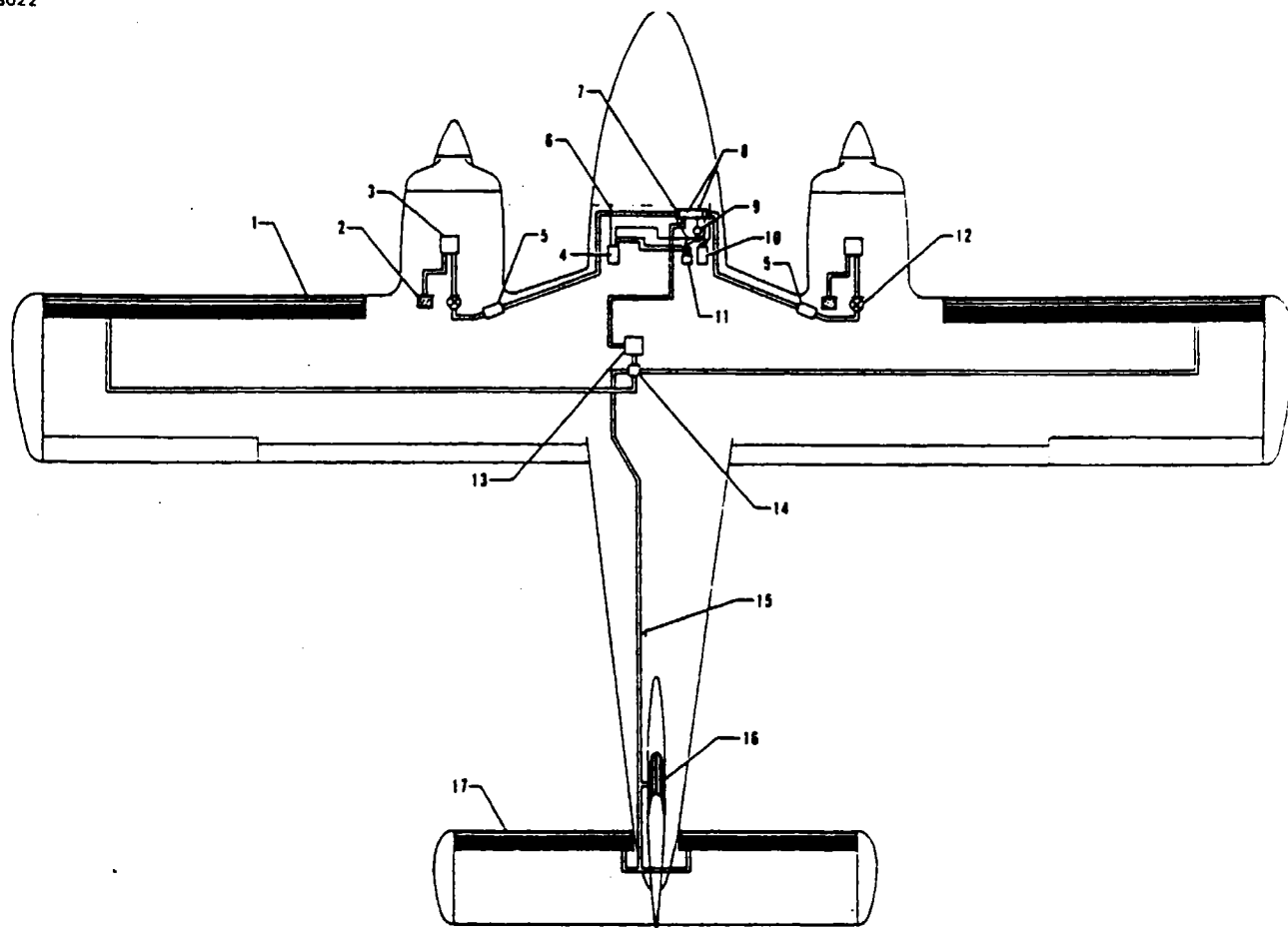

1. WING DEICER BOOTS
2. AIR FILTER
3. AIR PUMP
4. PILOT GYRO INSTRUMENT
5. IN LINE FILTER
6. OVERBOARD
7. MANIFOLD
8. CHECK VALVES
9. REGULATOR
10. COPILOT GYRO INSTRUMENT
11. PRESSURE GAUGE
12. DUAL STAGE PRESSURE REGULATING VALVE
13. TIME MODULE
14. EJECTOR FLOW CONTROL VALVE
15. PRESSURE SWITCH
16. TAIL DEICER BOOTS
17. STABILATOR DEICER BOOTS

Figure 14-15a. Pneumatic Deicer System Installation
(Serial Nos. 34-8070144 and up)

Added: 8/10/80

ACCESSORIES AND UTILITIES

3B16

Island Enterprises

14-34. PNEUMATIC DEICING SYSTEM.

14-35. INTRODUCTION. This portion of Section XIV provides service and maintenance procedures for the pneumatic deicing system. This information is current as of the time of this issue.

14-36. DESCRIPTION AND PRINCIPLES OF OPERATION. The deicer is essentially a fabric reinforced rubber sheet containing built-in inflation tubes. The type used in this installation have spanwise inflation tubes. Deicers are attached by means of a cement to the leading edges of the surfaces being protected. There are either aluminum or flexible rubber air connections on the backside of the deicer boots called "air connection stems." Each stem projects from the underside of the boot into the leading edge, through a round hole provided in the metal skin, for connection to the airplane's pneumatic air supply system.

Through an ejector valve, the system will normally apply vacuum to the deicer boots at all times, except when the boots are being inflated. Deicer inflation is effected by the deicer system control switch. This is a momentary ON type switch which returns to the OFF position when released. Through actuation of the momentary ON type switch, the timer energizes the pneumatic pressure control valves for six seconds. The boot solenoid valves are energized and air pressure from the engine driven pumps is supplied to the inflatable tubes in the boots. Inflation sequence is controlled by the timer and solenoid operated valves located near the deicer air inlets. The deicer pressure, normally 18 psig, is regulated by the high stage of the pneumatic pressure control valves. Upon automatic de-energization of the control valves by the timer, the deicer solenoid valves permit the deicer pressurizing air to return to the solenoid valves and be exhausted overboard. System vacuum is then reapplied to the boots to hold them close to the surface skin. Should reactivation of the boots be required, the momentary ON type switch is moved to the ON position again and released. The boots inflation cycle will again take place, with all boots inflating simultaneously.

A ply of conductive neoprene is provided on the surface to dissipate static electric charges. These charges, if allowed to accumulate, would eventually discharge through the boot to the metal skin beneath, causing static interference with the radio equipment and possible punctures in the rubber. Also, such static charges would constitute a temporary fire hazard after each flight.

14-37. TROUBLESHOOTING. In the utilization of the troubleshooting charts at the end of these instructions, it must be assumed that the engine driven pneumatic pumps and the airplane electrical system are operational. It is further assumed that the deicer system installation was made in an approved manner.

14-38. OPERATIONAL CHECK. The pneumatic deicing system should be checked at least every 100 hours. This check can be done on the ground. A visual inspection should be performed to determine the condition of the deicer boots, and any areas in need of repair should be taken care of before continuing with the operational check of the system.

With one engine operating, activate the deicing system switch. Observe the operation of the deicers carefully for evidence of malfunctioning. Look for tubes which leak or fail to inflate and deflate properly. Repeat the procedure for the other engine.

14-39. ELECTRICAL TEST. With engines off, turn airplane battery switch to ON position.

a. Timer: Activate the deicer system switch. The timer should begin to operate immediately and complete one full cycle of the system. If the timer does not function:

1. Reset circuit breaker and recheck.
2. Check circuit from power source, through circuit breaker, to switch, to timer, to ground.
3. Replace timer.

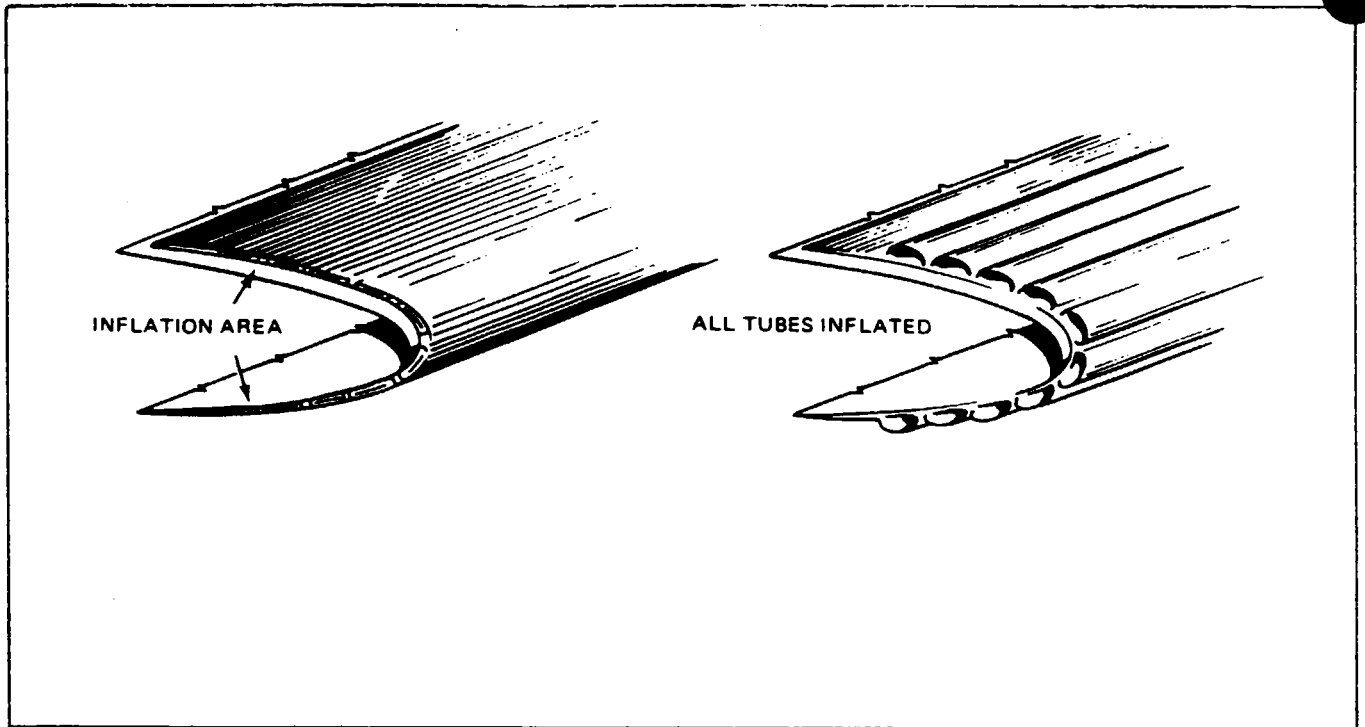

Figure 14-16. Pneumatic Deicer Boots Operation

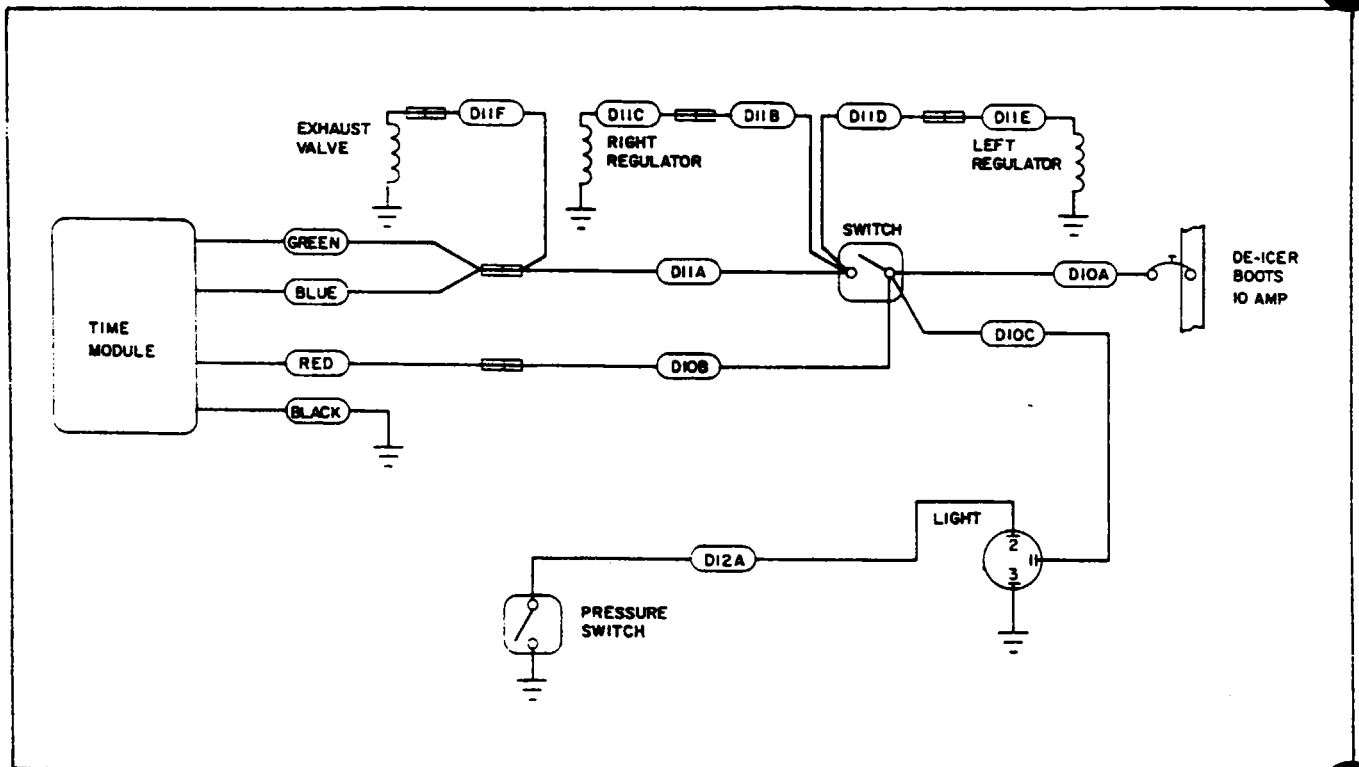

Figure 14-17. Pneumatic Deicer System Schematic

b. Solenoid Valves: Check both solenoid valves, one in each nacelle. Activate system switch to ON position. Solenoid valve should be actuated immediately for 6 seconds, as evidenced by an audible "click" that can be felt if hand is placed on a solenoid. If solenoid valve does not function:

1. Unplug electrical connector at solenoid. Attach test light or other suitable test equipment to connector and re-actuate system switch. If test equipment does not indicate complete circuit:
 - (a) Check circuit from timer, to solenoid connector, to ground.
 - (b) Replace timer.
2. Use ohmmeter to check solenoid for open circuit. If solenoid circuit is open, replace solenoid valve.
3. Remove solenoid safety wire and unscrew solenoid.

CAUTION

Do not lose steel hex actuator pin or valve poppet.

4. Reattach connector to solenoid, insert hex actuator pin into solenoid, and reactuate system switch. If pin is not ejected from solenoid, replace control valve.

14-40. PRESSURE LEAKAGE TEST.

- a. This test can be performed in either the left or right nacelles.
- b. Cap the overboard ports of the control valve.
- c. Connect a source of clean air to the inlet port of the control valve. It is necessary that the inlet pressure be a minimum of 18-20 psig to perform this test.
- d. Apply 18 psig pressure to the system by means of a hand operated valve, trip the pressure in the deicer system. Observe the system for leakage. The leakage rate should not exceed a pressure drop of 3.0 psig per minute.
- e. Remove test equipment, lubricate all threads, and replace all system components.

14-41. PNEUMATIC REGULATOR ADJUSTMENT.

- a. Remove the left and right pressure lines to the gyro pressure gauge.
- b. Install a 0 to 25 pounds per square inch (psi) pressure gauge in each line.
- c. Start the left engine. Operate the left engine at 2400 RPM.

CAUTION

During all engine operation specified herein, exercise caution to avoid harm or damage to personnel and equipment by propeller and propeller blast.

- d. Cycle the deicer boot system.
- e. Adjust the high pressure stage (rear section) of the dual stage pressure regulator which is located at the fire wall to maintain 18 ± 0.2 psi on the 0 to 25 psi pressure gauge while cycling. Recycle the deicer boot system as required to obtain and check this pressure setting.
- f. With the deicer boot system not being cycled (engine at 2400 RPM), adjust the low pressure stage (front section) of the dual stage pressure regulator to maintain 6 ± 0.2 psi on the 0 to 25 psi pressure gauge.
- g. With the engine at 2400 RPM, adjust the gyro pressure regulator located on the manifold forward of the right gyro to maintain $5 + 0.2 - 0.1$ inches of mercury on the gyro pressure indicator in the instrument panel.
- h. Shutdown the left engine. Repeat Steps c through g on the right engine. Further adjustment of the gyro pressure regulator (Step g) should not be required.
- i. With both engines operating at 2400 RPM, recheck pressure regulator stage cycling pressure (Step e. 18 ± 0.2 psi), low pressure regulator stage non-cycling pressure (Step f. 6 ± 0.2 psi), and gyro pressure indicator pressure (Step g $5 + 0.2 - 0.1$ inches of mercury).

Revised: 9/24/81

ACCESSORIES AND UTILITIES

3B19

j. Visually check all boots for operation. All cells shall inflate fully. The boot cycle time shall be 6 ± 2 seconds. (Cycle time is defined as the length of time the boots are fully inflated and does not include inflation and deflation time.)

14-42. COMPONENT MAINTENANCE AND REPLACEMENT.

14-43. FILTER REPLACEMENT. The pneumatic system contains two in line filters (1J4-6) and two fire wall mounted pump inlet filters (1J1-2).

a. Remove the in line filters (1J4-6) as follows:

1. If filters are located behind the instrument panel on the right and left side of the fuselage, remove the access panel from the aft wall of the nose baggage compartment. If the filters are located in the engine nacelle, remove the hatch cover from the top of the nacelle.
2. Disconnect the hoses from the filter and remove the filter.

NOTE

The 1J4-6 filters should be replaced at each 500 hours of operation.

3. Reinstall the filter in reverse order of removal with the flow indicator toward the hose from the manifold assembly. (Refer to Figure 14-20.)

b. Replace the fire wall mounted air filter 1J1-2 as follows:

1. Remove hatch cover from top of nacelle to gain access to the filter, which is mounted on the aft side of the fire wall and connected to the pneumatic pump with a length of flexible hose.
2. Remove the filter by disconnecting the hose and removing the nut and washer attaching the filter to the fire wall.
3. Reinstall the replacement filter in reverse order of removal.

NOTE

The 1J1-2 filter should be cleaned or replaced at each 100 hour inspection.

14-44. CONTROL VALVES. After 100 hours of engine operation, the valve poppet and internal lining of the control valve can become coated with a film of dried oil causing the valve to stick. To determine if valve poppet is sticking, perform electrical test. If solenoid checks satisfactory, remove valve poppet and clean control valve bore and poppet. To clean:

a. Remove safety wire and electrical connector. Unscrew solenoid.

CAUTION

Do not lose steel hex actuator pin.

b. Remove valve poppet. It may be necessary to apply slim nose pliers to pin projection to pull poppet from valve.

c. Thoroughly clean valve bore and poppet with commercial hydrocarbon type solvent.

d. Reassembly valve and resafety wire solenoid.

14-45. TIMER. No field maintenance is recommended. For repair or replacement, contact your B.F. Goodrich dealer or distributor.

TABLE XIV-V. OPERATING PRESSURES

Recommended Operating Pressure PSIG	Test Pressure in PSIG	
	MIN.	MAX.
15	13	17
18	16	20

14-46. INSPECTIONS. A ground check of the entire deicer system should be made at least every 100 hours. To permit ground checking the system without engine operation, a test plug is designed into all systems, usually between the pressure check valve and the combination unit.

Before checking the system, all deicers should be inspected for damaged areas and repaired according to the procedure in this section outlining the cold patch or vulcanized repairs. In order to check the system, refer to Table XIV-V and Paragraph 14-41 for operating pressures and check procedures.

14-47. GROUND PROCEDURE. After the test pressure range is established, connect an external source of air providing this pressure and a pressure gauge to the pneumatic deice line at the manifold assembly. Disconnect the deice line from the manifold to accomplish the test. The deicer system should be within one psig of the recommended operating pressure with each inflation cycle.

If deicers do not reach the operating pressure, check the inflation time to ascertain that the solenoid valves are open the specified length of time (six seconds). If this is not the cause of trouble or if the boots deflate slowly, the lines or valves may be plugged; then the lines should be disconnected and blown clear.

Check the timing of the system through several complete cycles. Boots ON six seconds, then OFF. The wing and empennage boots operate simultaneously. If cycle time is off the specified time, determine and correct the difficulty.

Inflation must be rapid to provide efficient deicing. Deflation should be completed before the next inflation cycle of the boots.

14-48. 100 HOUR INSPECTION. At each 100 hour inspection of the airplane, inspect and operate the deicer boots. Make checks as follows:

- a. Carefully inspect the deicers for evidence of damage or deterioration, and repair or replace damaged boots.
- b. Resurface boots which show signs of considerable wear or deterioration.
- c. Inspect all hose connections which form a part of the pneumatic deicing system. Replace deteriorated sections on non-kink hose.
- d. Check the operation of the boots and the operating pressure of the system as outlined in Paragraph 14-40 and Table XIV-V.
- e. If new or replacement boots have been installed, check the tube inflation to make sure that the air connection stems have been properly connected.
- f. Disconnect all drain lines in the system and check for proper drainage.
- g. Check the on-off control switch for freedom of action. Check associated electric wiring.
- h. Clean or replace the air filters.

CAUTION

Oil which reaches the deicers will cause rapid deterioration of the rubber. In cold weather, extreme care must be taken to see that engine oil does not collect in critical parts of the system and congeal. Congealed oil will cause sticking of the control valve and distributor valve. If sticking of these parts is encountered, remove from airplane, clean out and replace.

NOTE

This operation may be omitted if the boots were installed on the airplane subsequent to the last previous 100 hour check. On the other hand, if operations are being conducted under cold weather conditions below 10° F (-12°C), the air filters should be cleaned out at each 100 hour check, or more often if difficulties are encountered with valves sticking due to congealed oil.

14-49. REMOVAL OF BOOTS. The removal of deicer boots should be done in a well ventilated area to avoid difficulty from the fumes of the solvents. Materials required to remove the boots are: Turco 388 dried cement remover, Kelite 21, and a pressure handle squirt can. Proceed as follows:

NOTE

Disconnect line fittings from boot fittings.

- a. Starting at one corner of the upper trailing edge of the deicer, apply a minimum amount of solvent to the seam line while tension is applied to peel back the corner of the deicer.
- b. Using a pressure handle squirt can filled with solvent, separate the deicer boot from the surface for a distance of 4 inches all the way along the upper trailing edge.
- c. The area between the deicer and the wing which has now been separated will act as a reservoir for the solvent, therefore, the deicer can be pulled down towards the leading edge with a uniform tension.
- d. From the center line of the leading edge to the lower trailing edge of the deicer, use the pressure handle squirt can to soften the bond between the deicer and the wing skin.
- e. Use Kelite 21 or Turco 388 to clean the dry cement off the exposed wing area and clean the area thoroughly with MEK (MethylEthylKetone).

14-50. REPAIR OF BOOTS. Deicer repairs are classified as cold (temporary), made on the boot installed on the airplane, and vulcanized, made on the demounted boot in the shop. (Refer to Paragraph 14-54 for vulcanized repairs.)

14-51. COLD REPAIR. The materials and supplies for making cold repairs are listed in Table XIV-VI.

a. SCUFF DAMAGE. This type of damage will be most commonly encountered and, fortunately, it is not necessary in most cases to make a repair. On those rare occasions when the scuff is severe and has caused the removal of the entire thickness of surface ply in spots (the brown natural rubber underneath is exposed), repair the damage using Part No. 74-451-16 and proceed as follows:

1. Clean the area around the damage with a cloth dampened slightly with solvent. Buff the area around the damage with steel wool so that it is moderately but completely roughened. Wipe the buffed area with a clean cloth slightly dampened with solvent to remove all loose particles.

2. Select a patch of ample size to cover the damaged area. Apply one even thorough coat of cement, Part No. 74-451-20, to the patch and the corresponding damaged area. Allow cement to set a couple of minutes until tacky.

3. Apply the patch to the deicer with an edge, or the center adhering first. Work down the remainder of the patch carefully to avoid trapping air pockets. Thoroughly roll the patch with stitcher-roller, Part No. 74-451-73, and allow to set for ten to fifteen minutes.

4. Wipe the patch and surrounding area from the center outward with a cloth slightly dampened with solvent. Apply one light coat of A-56-B conductive cement, Part No. 74-451-11, to the patched area.

5. Satisfactory adhesion of patch to deicer will be reached in four hours. Deicer may be inflated for checking repair in a minimum of 20 minutes.

b. TUBE AREA DAMAGE. Repair cuts, tears, or ruptures to the tube area with fabric reinforced patches, Part No. 74-451-16, depending on size of damage.

1. Select a patch of ample size to cover the damage and to extend to at least 5/8 inch beyond the ends and edges of the cut or tear. If none of the patches is of proper size, cut one to the size desired from one of the larger patches. If this is done, bevel the edges by cutting with the shears at an angle.

NOTE

These patches are manufactured so that they will stretch in one direction only. Be sure to cut and apply the patch selected so that stretch is in the widthwise direction of the inflatable tubes.

2. Buff the area around the damage with buffing stick, Part No. 74-451-75, so that the surface is thoroughly roughened.

3. Apply the patch to the deicer with the stretch in the widthwise direction of the inflatable tubes, sticking edge of patch in place, working remainder down with slight pulling action so the injury is closed. Do not trap air between patch and deicer surface.

c. LOOSE SURFACE PLY IN DEAD AREA (NON-INFLATABLE AREA). Peel and trim the loose surface ply to the point where the adhesion of surface ply to the deicer is good.

1. Scrub (roughen) area in which surface ply is removed with steel wool. Scrubbing motion must be parallel to cut edge of surface ply to prevent loosening it. Scrub with steel wool and Toluol directly over all edges, but parallel to edges or surface ply to taper them down to the tan rubber ply.

2. Cut a piece of surface ply material, Part No. 74-451-23, to cover the damaged area and extend at least one inch beyond in all directions.

PIPER SENECA II SERVICE MANUAL

TABLE XIV-VI. MATERIAL AND SUPPLIES FOR COLD REPAIR

Part No.	Quantity	Description
74-451-C (FSN1650-856-7939)	1	Cold Patch Repair Kit (B. F. Goodrich Co.)
74-451-11	1/1 pt. can	A-56-B Conductive cement
74-451-16	30 pcs.	Small oval patch 1-1/4 x 2-1/2 in.
74-451-17	30 pcs.	Medium oval patch 2-1/2 x 5 inch
74-451-18	10 pcs.	Large oval patch 5 x 10 in.
74-451-19	3 pcs.	Patch 5 x 19 inch.
74-451-20	(2) 1/2 pt.	*No. 4 cement (patching only)
74-451-70	2	Cement brush 1/2 in.
74-451-73	1	1/8 in. Steel stitcher
74-451-75	6	Emery Buffing sticks
74-451-87	1	Buffing Shield
*This cement will give best results with the patches in this kit.		
The following items may be procured from the B. F. Goodrich Co., Akron, Ohio, or other manufacturer, as required:		
74-451-21	6 ft. roll x 6 in. wide	Type 21 or 22 fillet
74-451-22	15 ft. roll x 2 in. wide	Neoprene coated splicing tape
74-451-23	4 ft. long x 8 in. wide	Neoprene surface ply
74-451-24	1 quart	†EC-1403 cement and/or EC-1300 L
(FSN8040-628-4199 and/ or FSN8040-514-1880)		
74-451-74	1	2-1/2 in. sponge rubber roller
†Minnesota Mining and Manufacturing Company. Adhesives Division. 223-6N-02 3M Center, St. Paul, MN 55144 (612) 733-1237		

NOTE
TABLE XIV-VI CONTINUES ON THE NEXT PAGE.

TABLE XIV-VI. MATERIAL AND SUPPLIES FOR COLD REPAIR (cont.)

Part No.	Quantity	Description
<p>The following materials may be obtained from local supply:</p>	As required	Toluol
	<p>Clean, lint-free cloths (preferably cheese cloth)</p> <p>1 in. masking tape</p> <p>Sharp knife</p> <p>Steel measuring tape</p> <p>Fine sharpening stone</p> <p>Steel wool pads</p> <p>Hypodermic needles (22 gauge or smaller)</p>	<p>As required</p> <p>Rolls</p> <p>1</p> <p>6 ft. long</p> <p>1</p> <p>As required</p> <p>As required</p>
<p>Methylethylketone (MEK) can be used instead of Toluol, however MEK causes very rapid drying and provides only 10 seconds working time compared with 40 seconds for Toluol.</p>		

3. Mask off the damaged boot area 1/2 inch larger in length and width than the size of surface ply patch. Apply one coat of cement, Part No. 74-451-11, to damaged area and one coat to patch. Allow cement to set until tacky. Roll the surface ply to the deicer with 2 inch rubber roller, Part No. 74-451-74. Roll edges with stitcher-roller, Part No. 74-451-73. Apply just enough tension on the surface ply when rolling to prevent wrinkling and be careful to prevent trapping air. If air blisters appear after surface ply is applied, remove them with a hypodermic needle.

4. Clean excess cement from deicer with solvent.

d. **LOOSE SURFACE PLY IN TUBE AREA.** Loose surface ply in tube area is usually an indication of the deicer starting to flex fail. This type of failure is more easily detected in the form of a blister under the surface ply when deicer is pressurized. If this type of damage (or void) is detected while still a small blister (about 1/4 or 3/8 inch diameter) and patched immediately, the service life of the deicer will be appreciably extended. Apply repair patch as outlined in Paragraph a.

e. **DAMAGE TO FABRIC BACK PLY OF DEICER DURING REMOVAL.** If cement has pulled loose from the wing skin and adhered to the back surface of the deicer, remove it with steel wool and MEK. In those spots where the coating has pulled off the fabric, leaving bare fabric exposed, apply at least two additional coats of cement, Part No. 74-451-24. Allow each coat to dry thoroughly.

PIPER SENECA II SERVICE MANUAL

14-52. **VULCANIZED REPAIRS.** Due to the variety of boot damage possible, it is recommended that the B.F. Goodrich Company be contacted so they can determine the extent of damage and whether it is repairable by the vulcanized method or not. The overall condition of the deicer boot must be given careful consideration before deciding on any repairs. Damages can vary from minor punctures which may be easily repaired, to extensive ripping of the tube or stretch areas which may make repairs exceedingly difficult or actually impossible. The determination of just where this division between repairable and unrepairable damage exists will depend upon the careful judgment of the inspector. For this reason, we recommend contacting the B.F. Goodrich Company at Akron, Ohio.

14-53. **INSTALLATION.** The following procedure for installing deicers assumes that the airplane has provisions for air connections, etc.

NOTE

Balance stabilator per instructions in Section IV of this manual.

14-54. **PREPARATION OF LEADING EDGES.** If the leading edges are painted, remove all paint including zinc chromate primer.

a. With one inch (1) masking tape, mask off leading edge boot area, following 1/2 inch margin for non-recessed boots. Take care to mask accurately, thus eliminating the need for cleaning off excess cement later.

b. Clean the metal surfaces thoroughly, at least twice, with MEK or Acetone. For final cleaning, wipe the solvent film off quickly with a clean, dry cloth before it has time to dry.

NOTE

It is permissible to install deicers on alodined or anodized surfaces.

c. Fill gaps of skin splices that lead under deicers with sealing compound EC-801.

d. Remove the sump plugs from the air connection grommets. In some cases, it will be necessary to remove sections of doped fabric used to cover the air connection holes. Draw out the ends of the non-kink hose section so that they protrude through the connection holes in the leading edge. If hose is cracked or deteriorated, replace with new hose.

14-55. **PREPARATION OF DEICER.** Moisten a clean cloth with MEK or Acetone and carefully clean the rough, back surface of the boot at least twice. Change cloths frequently to avoid recontamination of the cleaned areas.

14-56. **MOUNTING DEICER ON LEADING EDGE.** Thoroughly mix EC-1403 cement before using. Apply one even brush coat to the cleaned back surface of the boot and to the cleaned metal surface. Allow the cement to air dry for a minimum of one hour. Apply a second coat to both surfaces and allow to air dry a minimum of one hour. Ambient temperature for installation should be held between 40° and 110° F. However, longer drying time of the cement coats may be required as the humidity approaches 99%. Deicer and leading edge may be cemented for a maximum of 48 hours before actual installation, if cemented parts are covered and kept clean.

Snap a chalk line along the leading edge of the airfoil section. Intensify chalk line on leading edge and the white reference line on the boot with a ball point pen. Most boots are made with an excess of material at the inboard and outboard edges for final trimming after installation and some recessed boots trim on the upper and lower edges.

Securely attach hose to deicer connections using clamps or safety wire.

a. Holding the backside of the boot close to the leading edge, fasten the end of each non-kink hose to the corresponding air connection stem. Tinnerman or other suitable non-kink hose clamps should be used for this purpose. Tighten each clamp with a pair of slip joint pliers but do not squeeze the clamp so tight that the hose is damaged.

NOTE

If non-kink hose clamps are not available, wrap each hose connection with several turns of friction tape. Over the tape, wrap two separate bindings of safety wire, about 1/2 inch apart. Each of these bindings should consist of several turns of wire. Twist together the ends of each binding to tighten. Press the twisted ends down against the hose. Finally, wrap the wire with several additional turns of friction tape.

b. Push the hose connections into the leading edge grommets or seals as the case may be. Obtain sufficient personnel to hold boot steady during installation. (Limit handling cemented side of boot with fingers.) Continue installation by reactivating the cement along the center line leading edge surface and boot in spanwise strips approximately six inches wide. Rubber roll the deicer firmly against the wing leading edge, being careful not to trap any air under the deicer. Always roll parallel to the inflatable tubes. Position the deicer center line to coincide with leading edge center line. Hold boot in this position while reactivating about three inches around connections and around corresponding holes in leading edge, using a clean, lint-free cloth moistened with Toluol. Insert connections in leading edge holes when cement has dried to a tacky state and rubber roll boot to leading edge in tackified area.

c. If the deicer should attach "off course," use MEK to remove and reposition properly. Avoid twisting or sharp bending of the deicer.

d. Rubber roll, apply pressure over entire surface of the deicer. All rolling should be done parallel to the inflatable tubes. Roll trailing edges with a narrow stitcher-roller.

CAUTION

Avoid excessive soaking or rubbing of the cement which could remove the cement from the surface.

Remove all masking tapes and clean surfaces carefully with Toluol so that no solvent will run under deicer edges.

e. Apply masking tape to deicer edges where exposed trimmed ends or gaps between sections are to be filled with MMM EC-801 sealing compound.

Apply masking tape to deicer approximately 1/4 inch in from trailing edges and tape wing skin approximately 1/4 inch from trailing edges, both forming a neat, straight line.

f. Apply a brush coat of A-56-B cement to surfaces between tapes and to EC-802 seams, being sure that the conductive coating (A-56-B) is continuous from the deicer surface to the wing painted surface.

g. Remove tapes immediately after applying A-56-B cement (before cement dries).

NOTE

Application of A-56-B conductive cement is not necessary on deicers that have "CONDUCTIVE" noted on labels.

CAUTION

The cements and solvents used for installation are flammable and their fumes slightly toxic. Therefore, all work should be done in a well ventilated area away from any sparks or flames. (Use of solvent resistant type gloves is recommended.)

In the event it becomes necessary to remove or loosen installed boots, use Toluol to soften the "adhesion" line. A minimum of this solvent should be applied to the seam line while tension is applied to peel back the boot. This removal should be slow enough to allow the solvent to undercut the cement, thus preventing injury to the part. Excessive quantities of solvent must be avoided.

14-57. ADHESION TEST. Using excess boot material trimmed from the ends of any wing and empennage deicers, prepare one test specimen for each deicer installed. This specimen should be a 1 x 8 inch full thickness strip of boot material cemented to the wing skin adjacent to installed boot following the identical procedure used for installation. Leave one inch of the strip uncemented to attach a clamp. Four hours or more after the installation, attach a spring scale to the uncemented end of each strip and measure the force required to remove strip at the rate of one inch per minute. The pull should be applied 180° to the surface. (Strip doubled back on itself.)

A minimum of five pounds tension (pull) shall be required to remove the test strip. If less than five pounds is required, then acceptability of the boot adhesion shall be based on the following tests:

- a. Carefully lift one corner of boot in question sufficiently to attach a spring clamp.
- b. Attach a spring scale to this clamp and pull with force 180° to the surface and in such a direction that the boot tends to be removed on the diagonal.
- c. If a force of five pounds per inch of width can be exerted under these conditions, the installation shall be considered satisfactory. Remember, the width increases as the corner peels back.
- d. Re-cement corner following previous procedure.
- e. Failure to meet this requirement shall result in reinstallation of the boot.

NOTE

Possible reasons for failure are: dirty surfaces, cement not reactivated properly, cement not mixed thoroughly. Corrosion of the metal skin may occur if good adhesion is not attained, especially around rivet heads and metal skin splices.

If these adhesion requirements are met, the airplane may be flown immediately. Do not inflate deicers within 12 hours of installation or until adhesion strength of 8 to 10 pounds is obtained.

14-58. MAINTENANCE. Clean deicers when the airplane is washed with a mild soap and water solution. In cold weather, wash the boots with the airplane inside a warm hangar if possible. If the cleaning is to be done outdoors, heat the soap and water solution before taking it out to the airplane. If difficulty is encountered with the water freezing on the boots, direct a blast of warm air along the region being cleaned, using a portable type ground heater.

As alternates, use Benzol or non-leaded gasoline. Moisten the cleaning cloth in solvent, scrub lightly, and then with a clean, dry cloth, wipe dry so that the cleaner does not have time to soak into the rubber. Petroleum products such as these are injurious to rubber and, therefore, should be used sparingly.

14-59. ICEX APPLICATION. B.F. Goodrich Icx is silicone base material specifically compounded to lower the strength of adhesion between ice and the rubber surfaces of airplane deicers. Icx will not harm rubber and offers added ozone protection.

Properly applied and renewed at recommended intervals, Icx provides a smooth polished film that evens out the microscopic irregularities on the surface of rubber parts. Ice formations have less chance to cling. Ice is removed faster and cleaner when deicers are operated.

It should be emphasized that Icx is not a cure-all for icing problems. Icx will not prevent or remove ice formations. Its only function is to keep ice from initially getting a strong foothold, thus making removal easier.

One 16 ounce pressurized can of Icx will cover deicer surfaces of the average light twin-engine plane approximately three times. It is also available in quart cans (unpressurized).

Before applying Icx, thoroughly clean deicer or other rubber surfaces with a rag dampened with non-leaded gasoline. Follow by a scrub wash of mild soap and water. Allow time for surfaces to dry.

Shake the Icx can well. Hold the nozzle approximately 12 inches from the surface and spray. Apply sparingly. If the application is too heavy, it results in a sticky surface which is very undesirable because it will pick up runway dust and prevent best ice removing efficiency.

Due to the natural abrasive effects on leading edges of deicers during flight, reapply Icx every 150 flight hours on wings and empennage deicers.

14-60. RESURFACING CONDUCTIVE CEMENT. The following materials are required to remove and replace the old, damaged coating:

- a. Fine grit sandpaper.
- b. Two inch paint brush.
- c. One inch masking tape.
- d. Conductive neoprene cement, No. A-56-B, B.F. Goodrich Company.
- e. Isopropyl Acetate, Federal Specification TT-1-721, as cleaning or thinning solvent.
- f. Alternate solvent (Toluol or Toluene may be used as an alternate for Isopropyl Acetate).

CAUTION

Cements and solvents used for resurfacing are flammable and their fumes slightly toxic. Therefore, all work should be done in a well ventilated area away from any sparks or flames.

PIPER SENECA II SERVICE MANUAL

During cold weather, place the airplane in a warm hangar and locate so that the boots are in line with one or more blast heaters. Do resurfacing before any other work on the airplane to allow as much time as possible for the new coat to cure.

NOTE

If for some reason the resurfacing cannot be done indoors, it may be deferred at the discretion of the inspector until a warm, clear day permits the work to be satisfactorily accomplished outdoors. However, if the deicers are in such condition that immediate resurfacing is required, remove them from the airplane and resurface in a shop.

Clean deicer thoroughly with Isopropyl Acetate.

- a. Roughen entire surface of boot, using a fine grit sandpaper.
- b. Clean surface again with clean, lint-free cloth moistened with cleaning solvent.
- c. Apply masking tape beyond upper and lower trailing edges, leaving a 1/4 inch gap of bare metal.
- d. Mask off any legible deicer brands.
- e. Apply one brush coat of A-56-B cement to deicer and allow to dry at least one hour. Then apply second coat and allow to dry at least four hours before operating deicers. Plane may be flown as soon as cement is dry.

NOTE

If A-56-B cement has aged 3 months or over, it may be necessary to dilute the cement with Isopropyl Acetate to obtain proper brushing consistency. Mix thoroughly, approximately 5 parts cement to one part Isopropyl Acetate.

TABLE XIV-VII. TROUBLESHOOTING CHART
(PNEUMATIC DEICER SYSTEM)

Trouble	Cause	Remedy
<p>Deicers do not inflate. Both engines operating at minimum cruise RPM or either engine at 2575 RPM.</p>	<p>Open circuit breaker.</p> <p>System connection loose or wire broken.</p> <p>Timer not functioning.</p> <p>Control valves not functioning.</p> <p>Lines blocked or not connected.</p>	<p>Push circuit breaker to reset.</p> <p>Tighten or repair as required.</p> <p>Test or replace as required.</p> <p>Make electrical test. Check for sticking poppet. Clean.</p> <p>Blow out lines and inspect connections. Make air leakage test.</p>
<p>Deicers inflate slowly (inflation time - 6 seconds).</p>	<p>Lines partially blocked or not connected securely.</p> <p>Deicer valve not functioning.</p> <p>System pressure not being reached.</p> <p>Deicer puncture.</p>	<p>Blow out lines and inspect connections. Make air leakage test.</p> <p>Check fitting in deicer port for proper installation.</p> <p>Check performance to manufacturers specifications.</p> <p>Repair per specification or replace.</p>
<p>Deicers deflate slowly.</p>	<p>Pressure regulator set too low.</p> <p>Lines partially blocked.</p> <p>Overboard line from control valve partially blocked.</p>	<p>Readjust pressure regulator.</p> <p>Inspect and blow out lines.</p> <p>Inspect and blow out lines.</p>

PIPER SENECA II SERVICE MANUAL

TABLE XIV-VII. TROUBLESHOOTING CHART
(PNEUMATIC DEICER SYSTEM) (cont.)

Trouble	Cause	Remedy
<p>Deicers inflate, indicator light does not function. (Ascertain that deicer boot switch is "ON.")</p>	<p>Indicator lamp burned out.</p> <p>System pressure not being reached.</p> <p>Pressure switch not functioning.</p> <p>Wires loose or broken. Poor grounding of pressure switch.</p>	<p>Replace lamp.</p> <p>Check "deicers inflate slowly above."</p> <p>Make electrical test and replace if required.</p> <p>Make electrical test. Repair or replace broken wires. Check for proper ground.</p>

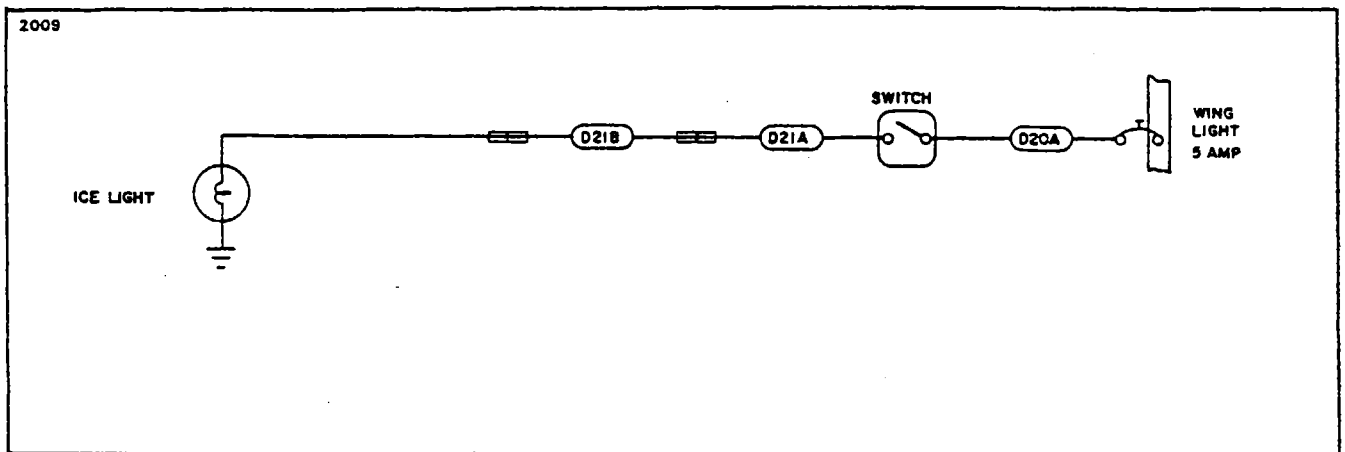

Figure 14-18. Ice Detection Light Schematic

14-61. ICE DETECTION LIGHT.

14-62. INTRODUCTION. This light is used in conjunction with the pneumatic deicing system and will aid the pilot to detect any ice formation on the left wing leading edge during night flying operations.

14-63. DESCRIPTION AND OPERATION. The light is mounted in the left outboard edge of the left nacelle just above leading edge of the wing. It is a sealed beam, 12-volt unit, which is controlled from a rocker type switch mounted on the switch panel. The light is positioned in the nacelle to illuminate the leading edge of the wing when the switch is activated in the cockpit.

14-64. SERVICING. The only service required of this unit is the replacement of a burned out lamp with a new lamp GE1383.

14-65. REMOVAL.

- a. Be sure the switch is in the off position.
- b. Remove the top access panel from the left nacelle.
- c. Within the nacelle, remove the screws that secure the socket in the retainer.
- d. Pull the socket aft and remove the lamp.

14-66. INSTALLATION.

- a. Position the new lamp in the receptacle of the socket, then secure the socket in the retainer with the screws.
- b. Activate the switch in the cockpit to check the lamp operation.
- c. Replace the nacelle access panel with the attachment hardware.

PIPER SENECA II SERVICE MANUAL

14-67. HEATED WINDSHIELD PANEL.

14-68. DESCRIPTION. The heated windshield panel is a rectangular glass panel containing electrically heated wires imbedded in the glass which is mounted in a metal frame. The assembly is mounted on the exterior side of the pilot's windshield and is hinged at its base to facilitate windshield cleaning. The heated panel is operated by a circuit breaker type switch located in the console below the throttle quadrant.

14-69. REMOVAL AND INSTALLATION OF HEATED PANEL.

- a. Disconnect the electrical connector located next to the heated panel on the exterior side of the windshield, by removing the two screws and pulling the plug out of the receptacle.
- b. Remove the two screws which attach the panel assembly to the windshield collar and remove the panel from the airplane.
- c. If the airplane is to be flown with the heated panel removed, rotate the receptacle plate 180 and replace it to cover the holes in the fuselage skin, also replace the windshield collar screws.
- d. Installation of the heated windshield panel is accomplished in the reverse order of removal.

INTENTIONALLY LEFT BLANK

14-70. OXYGEN SYSTEM.

14-71. DESCRIPTION AND PRINCIPLE OF OPERATION. The standard oxygen system for the PA-34-200T consists of two automatic, constant flow, portable oxygen units. The two units are secured between the two middle seats and act as an armrest. The two systems serve as a safety feature, the pilot on one system and the copilot on the other. The four passengers obtain their oxygen from the "Y" adapters on each system. Each oxygen cylinder is an ICC regulation 3AA with a 22 cubic foot capacity.

A fixed oxygen system to provide supplementary oxygen for the crew and passengers during high altitude flights (above 10,000 feet) is available as optional equipment. The major components of the Scott oxygen system are a 63 cubic foot oxygen cylinder, an oxygen supply gauge, an on-off flow control knob, a pressure regulator, six plug in receptacles and six oxygen masks.

The oxygen cylinder is mounted aft in the tail cone. When fully charged, the cylinder contains oxygen at a pressure of 1850 psi at 70° F. The oxygen supply gauge is mounted in the aft overhead vent duct. The oxygen flow control knob, labeled "Pull-On" is mounted in the pilot's overhead panel. The pressure regulator is mounted directly on the oxygen cylinder, once the oxygen flow control knob is on, each of the oxygen plug-in receptacles operates as an automatic on-off valve. The oxygen cylinder can be recharged through the filler valve aft of the cabin door on the right side of the fuselage (fuselage sta. 222.43). When oxygen is required, the control knob should be pulled forward to the ON position, allowing oxygen to flow from the cylinder through the system. Connecting the constant flow mask fitting to a receptacle and turning it 90 degrees clockwise, automatically releases oxygen to the mask through the on-off valve feature of the receptacle. The occupant then dons the mask and breathes normally for a sufficient supply of oxygen.

Each mask assembly oxygen line incorporates a flow indicator. When the red pellet in the indicator disappears, oxygen is flowing through the line normally. If the red indicator appears in any of the lines during a period when oxygen use is essential, the airplane should be lowered to a safe altitude immediately.

To stop the flow of oxygen through the system, the control knob should be pushed aft to the OFF position. To bleed down low pressure lines, it is recommended that the mask assembly be left connected to the outlet for at least three minutes after the control knob is turned off.

When not in use, mask may be stowed in the storage pockets behind the front and center seats. Always remove fittings from the oxygen receptacles and stow the mask when they are not in use. If the control knob is pulled on and the fitting is in the receptacle, oxygen will flow through the mask continuously. Masks may be damaged if they are not properly stowed.

14-72. TROUBLESHOOTING. A troubleshooting chart is located at the back of the oxygen system portion of this section.

14-73. SAFETY PRECAUTIONS. Utmost care must be exercised in servicing, handling and inspection of the oxygen system. A fully charged oxygen cylinder contains enough pressure to cause serious injury to personnel and damage to equipment. Keep hands, tools and working area clean and post NO SMOKING signs. Keep all components of the system free from oil, grease, fuel and all ready combustible material. Never allow electrical equipment to come in contact with the oxygen cylinder. Keep fire and heat away from oxygen equipment and take care not to generate sparks with carelessly handled tools.

14-74. INSPECTION AND OVERHAUL TIME LIMITS. It is recommended that inspection and overhaul be conducted by an FAA Approved Station or the manufacturer, Scott Aviation. The following checks and chart gives recommended inspection and overhaul time for the various parts of the oxygen system:

PIPER SENECA II SERVICE MANUAL

- a. Standard weight cylinders (ICC or DOT 3AA 1800 classification) must be hydrostatic tested every 5 years. The lightweight cylinders (ICC or DOT 3HT 1850 classification) must be hydrostatic tested every 3 years and must be retired from service after 15 years or 4380 pressurizations, whichever occurs first. The month and year of the last test is stamped on the cylinder beneath the ICC or DOT identification.
- b. The outlets should be checked for leakage both in the non-use condition and for leakage around an inserted connector.
- c. The high pressure gauge may be checked for accuracy by comparing its indicated pressure with that of a gauge of known accuracy.
- d. Inspection of the regulator may be effected by introducing into an outlet a mask connector to which is attached a 100 psi gauge. With one other outlet flowing through a plugged in mask, the indicated regulator output pressure shall be not less than 45 psi at sea level with 200 psi supply cylinder pressure. It should be noted that the permissible leakage through the 1/16 diameter vent hole in the side of the upper regulator housing is 10 cc/min. maximum, when the regulator is turned on. There shall be no external leakage anywhere on the regulator when it is turned off. All fittings shall be leak free.

14-75. TESTING FOR LEAKS. Apply detector fluid type CD-1 solution or its equivalent. The solution should be shaken to obtain suds or foam. The suds or foam should be applied sparingly to the joints of a closed system. Look for traces of bubbles. No visible leakage should be found. Repair or replace any defective parts and retest system. With the system pressurized to service pressure, further tests can be made. The rate of any leak should not exceed one percent of the total supply per 24 hour period. All traces of the detector fluid should be wiped off at the conclusion of the examination.

14-76. MAINTENANCE.

- a. Check that all lines have sufficient clearance between all adjacent structures and are secured in place. Also check the cylinder to be sure it is securely mounted (See Figure 14-20a).
- b. Check the cylinder for the ICC identification number and for the date of the last FAA inspection and test.
- c. If cylinder is completely empty, it must be completely disassembled and inspected in an FAA approved facility before recharging.
- d. Any lines that are defective should be replaced with factory replacements.
- e. Clean all lines and fittings as described in Paragraph 14-77.
- f. Use Ribbon Dope Thread Sealant (Permacel 412) on male ends of fittings only. Wrap thread in direction of thread spiral, beginning with the second thread on the fitting. Avoid getting any sealant into the lines.

14-77. CLEANING OPERATIONS. To remove oil and grease from tubing and fittings, one of the following cleaning methods may be used:

PP-00076.

- a. First Method:
 1. A vapor degreasing with stabilized Trichlorethylene conforming to Specification MIL-T-7003 or Piper safety solvent (914 905).
 2. Blow tubing clean and dry with a stream of clean, dry filtered air or nitrogen. Care shall be taken to insure that the interior of the tubing and fittings are thoroughly cleaned.
- b. Second Method:
 1. Flush with naphtha conforming to Specification TT-N-95.
 2. Blow clean and dry off all solvent with clean, dry, filtered (oil-free) air.
 3. Flush with isopropyl alcohol.
 4. Rinse thoroughly with fresh water.
 5. Dry thoroughly with a stream of clean, dried, filtered air (oil free) or by heating at a temperature of 250° to 300° F one half hour.

TABLE XIV-VIII. OXYGEN SYSTEM COMPONENTS LIMITS

PARTS	INSPECTION	OVERHAUL
Regulator	300 Flight Hrs.	5 Yrs.
Pressure Gauge	300 Flight Hrs.	5 Yrs.
High Pressure Lines	300 Flight Hrs.	
Low Pressure Lines	300 Flight Hrs.	
Outlets	300 Flight Hrs.	5 Yrs.
External Recharge Valve	Each Use	Replace Every 5 Yrs.
Masks	Each Use	Replace as Necessary

6. The solvents may be reused provided they do not become excessively contaminated with oil. This condition shall be determined as follows:

(a) Completely evaporate 100 milliliters of the liquid in a weighed glass dish. Evaporation may be accomplished by heating at 200° F for approximately one-half hour.

(b) After evaporation, cool and weigh the residue. The solvent shall not be used if the residue exceeds 100 miligrams in weight.

c. Third Method:

1. Flush with hot inhibited alkaline cleaner until free from oil and grease.

2. Rinse thoroughly with fresh water.

3. Dry thoroughly with a stream of clean, dry, filtered (oil-free) air or by heating at a temperature of 250° to 300° for one half hour minimum.

CAUTION

To preclude the possibility of fire by spontaneous combustion, oil, grease, paint, hydraulic fluid and other flammable material should be kept away from oxygen equipment.

14-78. PURGING THE SYSTEM. The system should be purged whenever the cylinder pressure falls below 50 psi or if any lines are left open for any length of time. Also, whenever there are any offensive odors present, it will be necessary to purge the system. Use the following procedure:

a. Park the airplane in a NO SMOKING area.

b. Keep all doors and windows open.

c. Be sure all electrical systems are shut off.

d. Connect the oxygen recharging unit to the filler valve.

e. Plug the oxygen masks into the outlet valves and turn on the system.

f. Set the recharging unit pressure regulator to deliver 50 psi and let the system purge for one hour. If any odor is still present, repeat the procedure for one or more hours. If the odor persists after the second purging, replace the cylinder.

PIPER SENECA II SERVICE MANUAL

14-79. REMOVAL OF PORTABLE OXYGEN UNIT. (Refer to Figure 14-19).

— WARNING —

Do not use grease or any grease type fittings on any hardware that connects to the oxygen bottle or system hardware. When working with the system make sure hands, clothing, and tools are free of oil, grease and dirt when working with the oxygen system.

The oxygen unit can be released from its cradle by pulling down on the ring under the cradle, sliding the unit forward, and lifting it out of its cradle.

CAUTION

Use only aviation breathing oxygen when having the oxygen bottles charged. MIL-0-27210C specifies that the moisture content of aviation breathing oxygen must not exceed 0.005 milligrams of water vapor per liter of gas at a temperature of 70° F and a pressure of 760 millimeters of Hg.

14-80. CHARGING. For recharging a low pressure aircraft oxygen system or portable cylinders, it is essential that the oxygen trailer or cart have a pressure-reducing regulator. Military types E-2 or C-1 reducing regulators are satisfactory. These types of regulators reduce the large cylinder pressure from 2000 psi to a line pressure of 450 psig.

CAUTION

When refilling the low pressure system, open the oxygen filler tank valve slowly to allow the system to be filled at a slow rate. After the refilling operation is completed, check for leaks with a leak detector.

- a. Inspect the cylinder being charged for damage, cleanliness, and date of hydrostatic test.
- b. Connect cylinder valve outlet to the refilling manifold.
- c. Slowly open valve of cylinder to be charged and observe pressure on gauge of manifold system.
- d. Slowly open valve of cylinder on manifold system having the lowest pressure and allow pressure to equalize.
- e. Close cylinder valve on manifold system and slowly open valve of cylinder having next highest pressure. Continue this procedure until the cylinder has been charged.

14-81. REMOVAL OF OUTLETS.

1. Make sure control valve is in full OFF position.
2. Connect a mask or connector to the valve to release any pressure.
3. Using a suitable wrench, remove the outlet.
4. The outlet can now be removed from the low pressure line.

14-82. INSTALLATION OF OUTLETS.

1. Apply sealant (Permacel 412) to the male end of the fitting.
2. Install the outlet to the regulator extension with a suitable spanner wrench.
3. Torque the fittings into the outlets approximately 30 inch-pounds. Do not overtorque as this could damage the outlet.

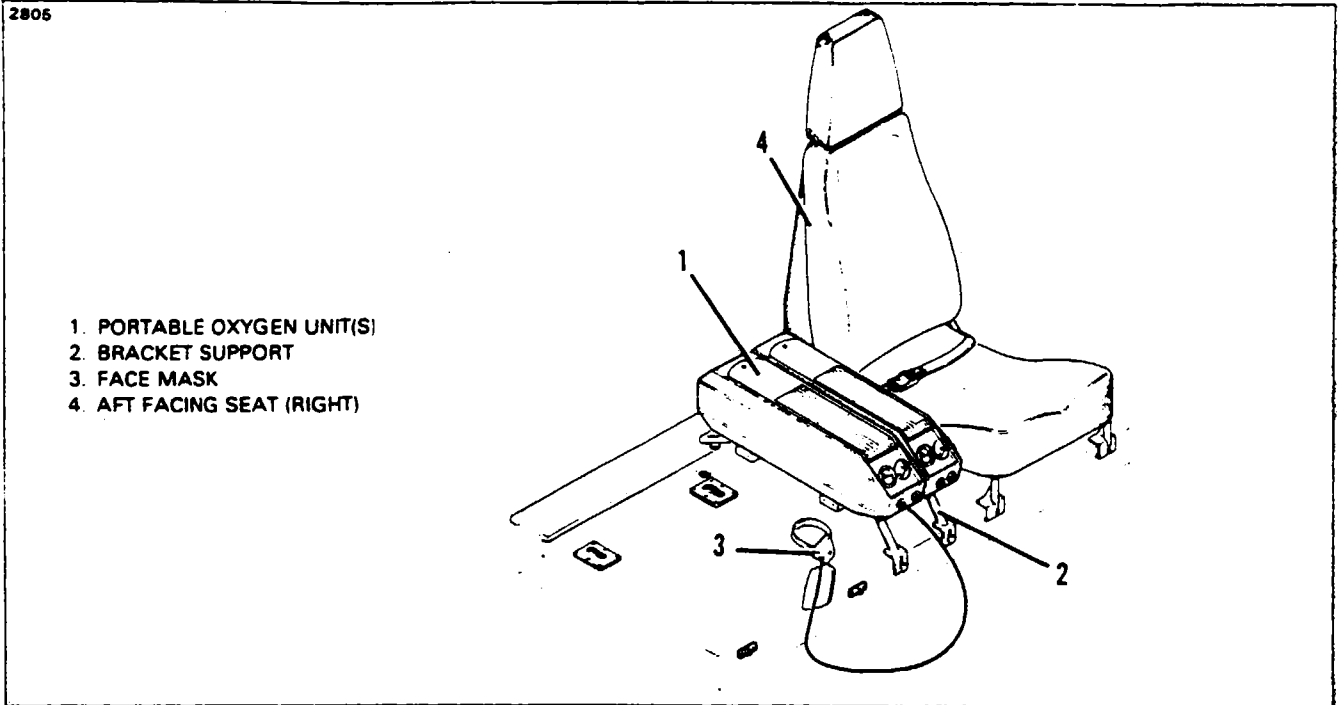

Figure 14-19. Portable Oxygen Installation

14-83. CLEANING OF FACE MASKS. (PORTABLE SYSTEM)

The disposable masks are designed for one-time use and require no maintenance. The pilot's and copilot's masks can be cleaned as follows:

1. Remove the microphone from the mask.
2. Remove the sponge rubber discs from the mask turrents. Do not use soap to clean sponge rubber discs, as this would deteriorate the rubber and give off unpleasant odors. Clean in clear water and squeeze dry.
3. Wash the rest of the mask with a very mild solution of soap and water.
4. Rinse the mask thoroughly to remove all traces of soap.
5. Make sure the sides of the breathing bag do not stick together while drying, as this may decrease the life of the rubber in the bag. The mask can be sterilized with a solution of 70 percent ethyl alcohol.

14-84. CLEANING OF FACE MASKS. (Fixed System)

- a. Remove the sponge rubber discs from the mask turrents. Do not use soap to clean sponge rubber discs, as this would deteriorate the rubber and give off unpleasant odors. Clean in clear water and squeeze dry.
- b. Wash the rest of the mask with a very mild solution of soap and water.
- c. Rinse the mask thoroughly to remove all traces of soap.
- d. Make sure the sides of the breathing bag do not stick together while drying, as this may decrease the life of the rubber in the bag. The mask can be sterilized with a solution of 70 percent ethyl alcohol.

Revised: 8/10/80

ACCESSORIES AND UTILITIES

3C15

PIPER SENECA II SERVICE MANUAL

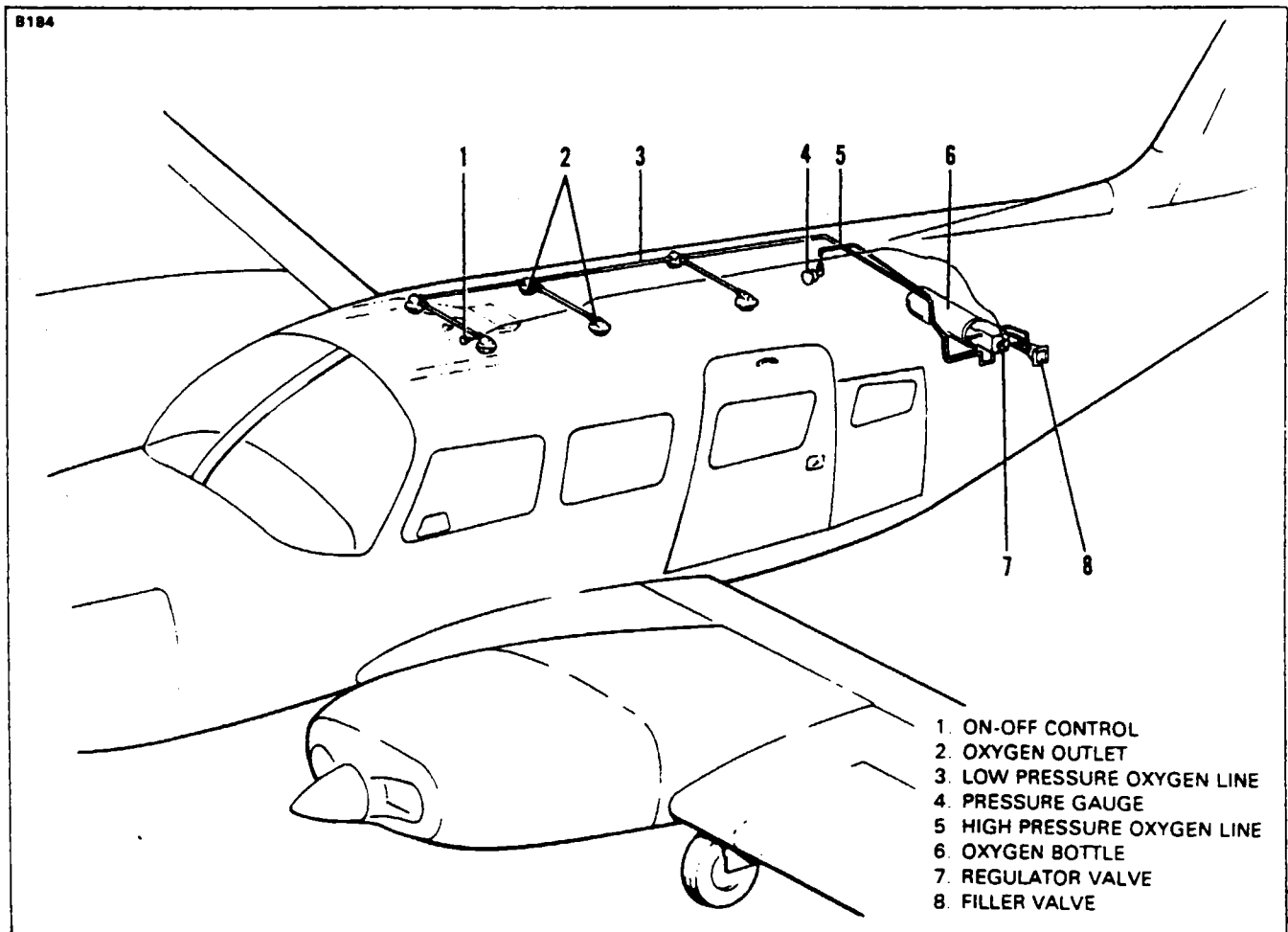

Figure 14-20. Fixed Oxygen System Installation (Optional)

14-85. REMOVAL OF OXYGEN CYLINDER AND REGULATOR. (Fixed System) (Refer to Figures 14-21 and 14-22.) The oxygen cylinder is located in the tail section at station 222.437.

- a. Remove the rear bulkhead door assembly.

CAUTION

Be sure the valve on the cylinder is closed before disconnecting any lines from the regulator.

- b. Remove the oxygen cylinder shroud clamps.
- c. Remove control cable from the regulator assembly.
- d. Remove the two screws securing the halves of the oxygen cylinder shroud together.
- e. Carefully slide the shroud halves apart.
- f. Disconnect the pressure lines from the regulator.

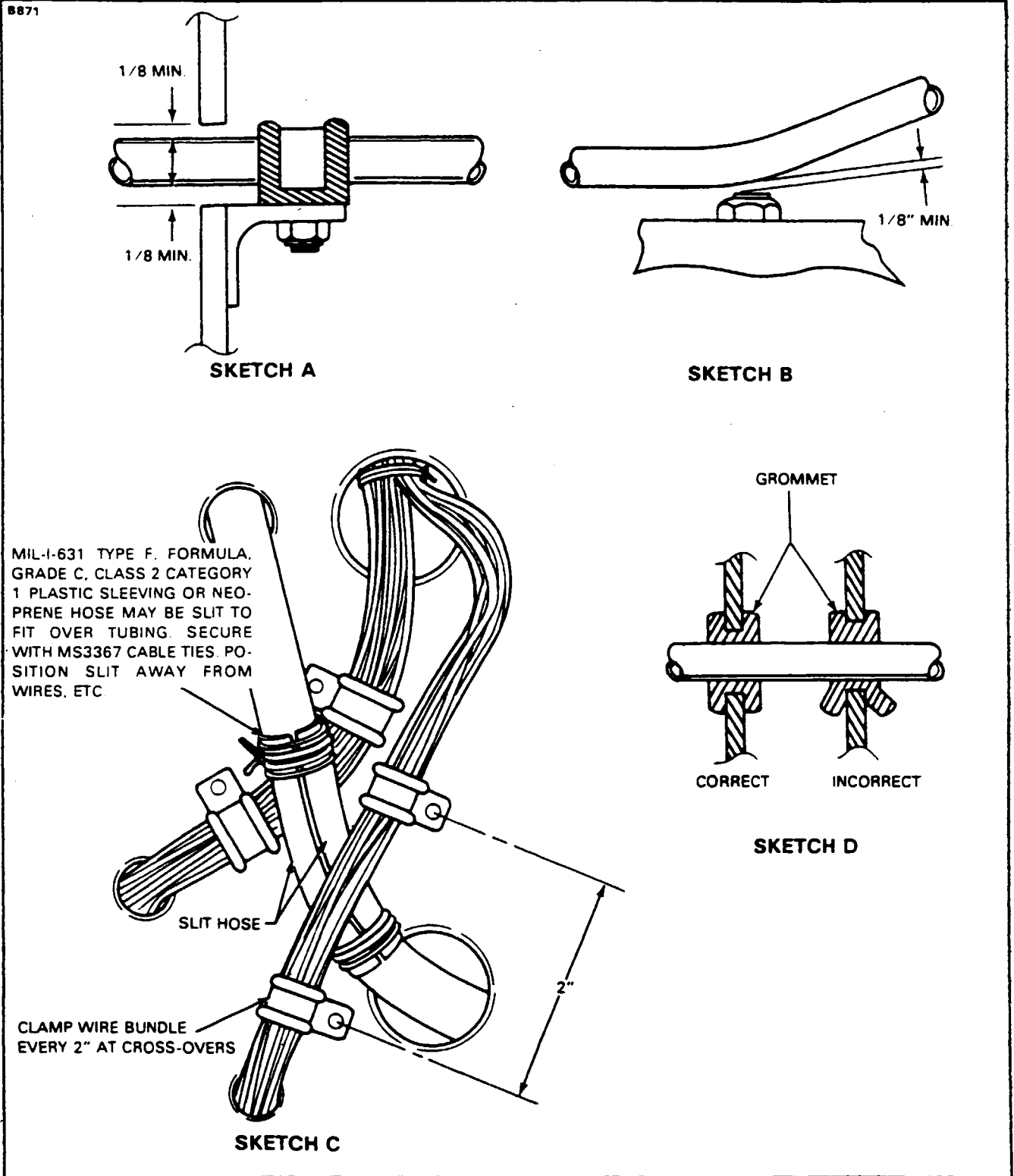

Figure 14-20a. Oxygen Tubing Installations

Revised: 12/08/83

3C17

ACCESSORIES AND UTILITIES

PIPER SENECA II SERVICE MANUAL

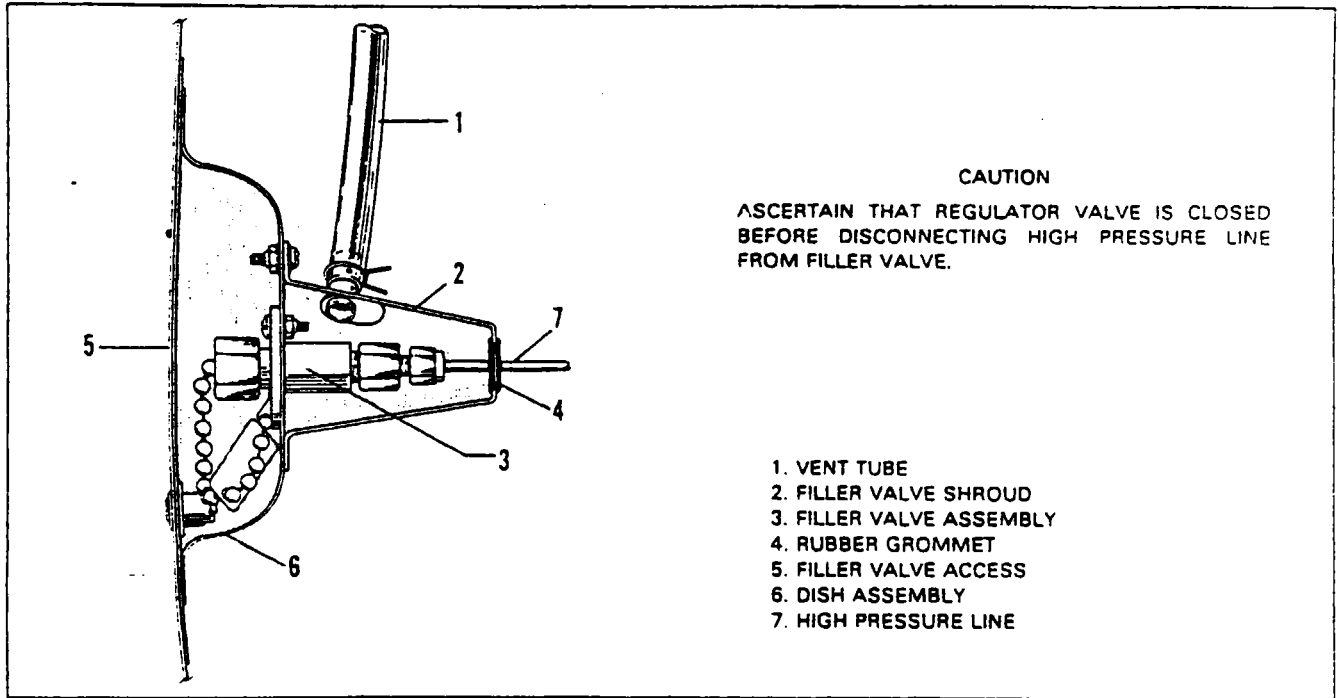

Figure 14-21. Oxygen System Filler Valve Installation

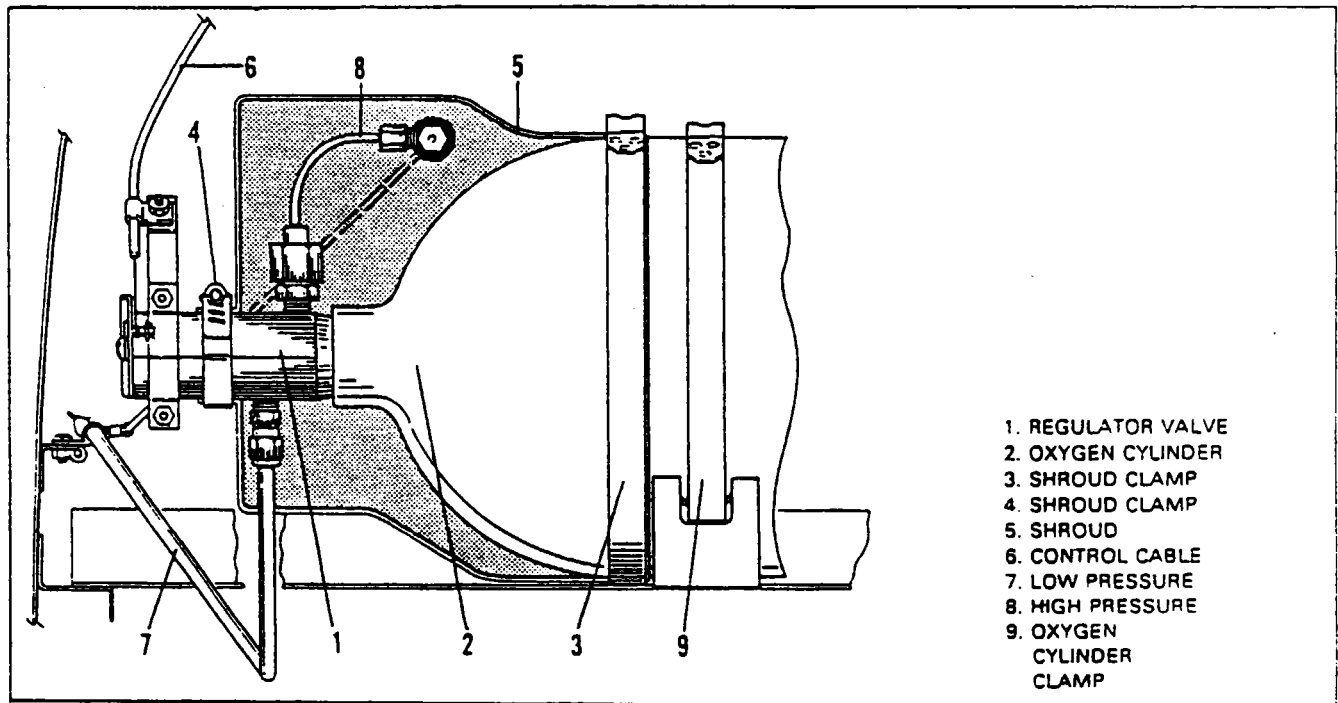

Figure 14-22. Oxygen Cylinder and Regulator Assembly

- g. Remove the clamps securing the oxygen cylinder to the oxygen bottle shelf assembly and remove the cylinder from the airplane.

CAUTION

Ascertain that the cylinder is empty before removing regulator.

14-86. INSTALLATION OF OXYGEN CYLINDER AND REGULATOR. (Fixed System)

- a. Place the cylinder and regulator assembly into position through bulkhead door assembly. Align regulator with control cable and secure cylinder with clamps.
- b. Connect the pressure lines to the regulator.
- c. Slide the shroud halves together and secure with two clamps and two screws.
- d. Attach control cable to the regulator assembly.
- e. Check for security of installation and install rear bulkhead door assembly.
- f. Recharge the oxygen cylinder if not already accomplished.

14-87. REMOVAL OF FILLER VALVE. (Figure 14-21)

- a. Remove the rear bulkhead access panel.
- b. Ascertain that the valve on the regulator is closed.
- c. Remove the three screws and washers which secure the filler valve shroud (2) to the filler valve dish (6) assembly. Slide shroud away from dish.
- d. Disconnect the high pressure line (7) from the filler valve (3).
- e. Remove the three screws, washers and nuts which secure the filler valve (3) to the dish assembly (6) and remove the filler valve.

14-88. INSTALLATION OF FILLER VALVE (Figure 14-21)

- a. Place the valve into position and secure with three nuts, washers and screws.
- b. Connect the high pressure line (7) to the valve (3).
- c. Slide the filler valve shroud (2) into position and secure with screws and washers.
- d. Install the rear bulkhead access panel.

14-88a. OXYGEN TUBING CLEARANCE (Refer to Figure 14-20a.) When installing oxygen tubing for the fixed oxygen system maintain the following clearances between the tubing and components.

- a. Maintain a two inch minimum clearance between the oxygen tubing and all flexible moving parts (such as flexible control cables) of the aircraft. If this is not possible, protection from abrasion should be provided.
- b. Maintain a one-half inch minimum clearance between oxygen tubes and all rigid moving parts of the aircraft such as levers and rigid control rods.
- c. Maintain a six inch minimum separation between oxygen tubes and hydraulic system tubing and components, fuel system tubing and components and electrical wiring.
- d. If the conditions of the previous step cannot be met, the following requirements must be complied with.
 - 1. Electrical cables, other tubing (etc.) will be supported at least every two inches so that they cannot chafe the protective tubing over the oxygen tubing. (Refer to sketch c of Fig. 14-20a.)
 - 2. The oxygen tube will be protected by a rubber neoprene hose or plastic sleeving per Sketch C of Figure 14-20a.
- e. For open type clamps, the rubber pad of the clamp provides sufficient clearance, providing the center-line of the tube remains parallel to the clamp support bracket. (Refer to sketch a of Fig. 14-20a.)
- f. Where an oxygen tube passes through a grommet (sketch D, Figure 4-20a), the tube must not bear on the grommet in such a way as to cause cutting of the grommet in service.

PIPER SENECA II SERVICE MANUAL

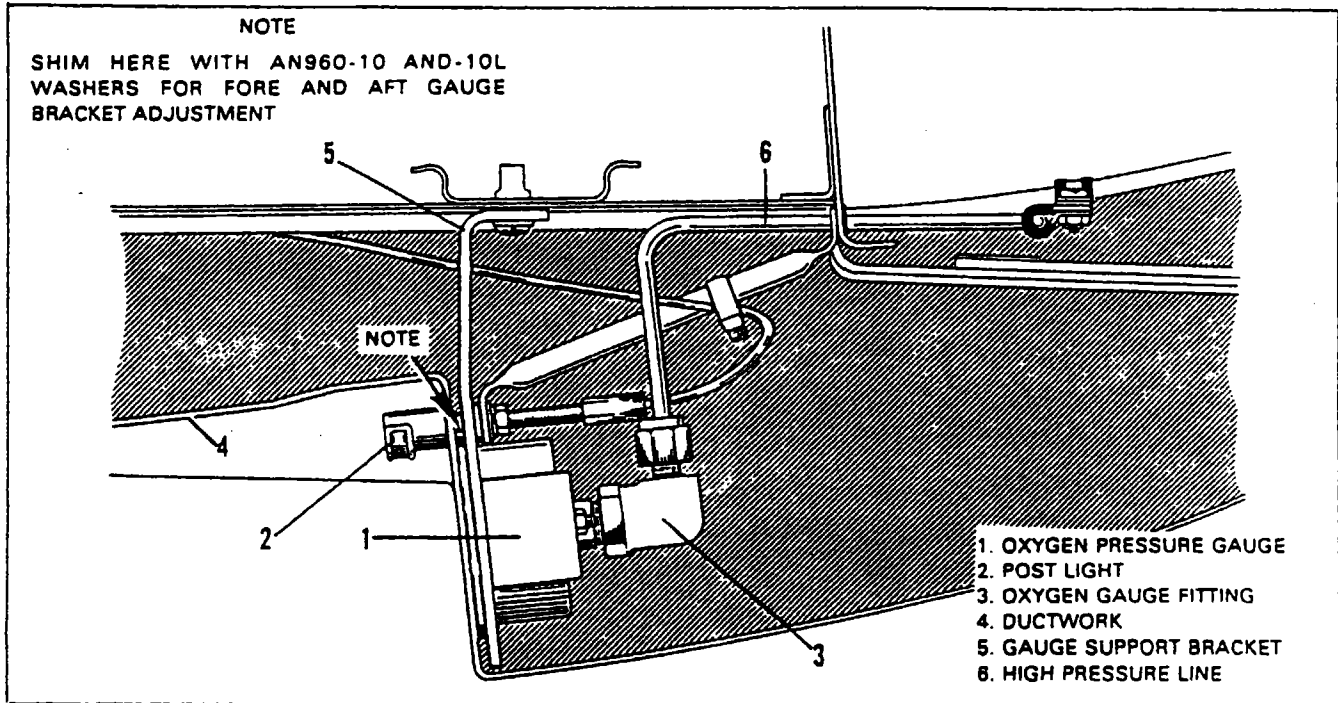

Figure 14-23. Oxygen Pressure Gauge Installation

g. Maintain a minimum $\frac{1}{8}$ " clearance between an oxygen tube and a projection such as a bolt, nut (etc.) when there is no relative motion. If relative motion will exist in service, allow a sufficient initial clearance which will allow, under the maximum relative motion, a minimum clearance of $\frac{1}{8}$ ". This applies to low pressure distribution lines only. High pressure distribution lines require a $\frac{1}{2}$ " minimum clearance.

14-89. REMOVAL OF PRESSURE GAUGE. (Refer Figure 14-23)

The oxygen pressure gauge is mounted in the overhead ductwork just forward of the cabin rear bulkhead. Ascertain that the control valve is closed and there is no pressure in the system.

- Remove the overhead ductwork surrounding the pressure gauge.
- Disconnect the high pressure line from the oxygen pressure gauge fitting.
- Loosen and remove the retainer nut and clamp securing the gauge to the bracket and remove the gauge.

14-90. INSTALLATION OF PRESSURE GAUGE. (Refer Figure 14-23)

- Place the gauge in its support bracket and secure with the clamp and retainer nut previously removed.
- Connect the high pressure line to the gauge fitting.
- Install the ductwork previously removed.

14-91. REMOVAL OF OUTLETS.

- Using a suitable spanner wrench, remove the outer half of the outlet.
- Remove the screws holding the trim panel and remove the panel.
- The outlet can now be removed from the low pressure line.

TABLE XIV-IX. TROUBLESHOOTING CHART (OXYGEN SYSTEM)

Trouble	Cause	Remedy
<p>No indication of pressure on pressure gauge.</p>	<p>Cylinder empty or leak in system has exhausted pressure.</p> <p>Pressure gauge defective.</p> <p>Defective regulator.</p>	<p>Change system and check for leaks.</p> <p>Replace pressure gauge.</p> <p>Replace regulator</p>
<p>Pressure indication normal but no oxygen flowing.</p>	<p>Oxygen cylinder regulator assembly defective.</p> <p>Control out of adjustment.</p>	<p>Replace regulator assembly.</p> <p>Adjust control.</p>
<p>Offensive odors in oxygen.</p>	<p>Cylinder pressure below 50 psi.</p> <p>Foreign matter has entered the system during previous servicing.</p>	<p>Purge the oxygen system. Refer to Paragraph 14-12.</p>

PIPER SENECA II SERVICE MANUAL

14-92. INSTALLATION OF OUTLETS.

- a. Apply a sealant to the male end of the fitting.
- b. Connect the outlet to the low pressure line.
- c. Position the trim panel and secure with screws.
- d. Position the outer half outlet and secure with a suitable spanner wrench.
- e. Torque the fittings into the outlets approximately 30 inch-pounds. Do not over torque as this could damage the outlet.

14-92a. **THREAD SEALANT.** Teflon tape (3M No. 48) shall be used on all tapered pipe threads. Do not use teflon tape on straight threads. Do not use any other lubricant on any fitting threads. PPS40087F

- a. Wrap tape on male threads in the direction of the thread spiral. Circle the threads and join the ends of the tape with a slight overlap.
- b. The tape shall not extend beyond the first thread.

INTENTIONALLY LEFT BLANK

14-93. AIR CONDITIONING INSTALLATION.

14-94. DESCRIPTION. This installation consists of a compressor with its special bracketry, an evaporator, a condenser, a receiver-dehydrator, circulating fan, thermal expansion valve, and related plumbing.

The evaporator filters, dehumidifies and cools the air. The evaporator is mounted in a fabricated housing along with the receiver-dehydrator, circulating fan, thermal expansion valve and related plumbing. This housing is located at the rear of the cabin, aft of the baggage area. The compressor is a piston type unit which is supported by special bracketry at the rear of the engine. A V-belt connection drives the compressor through a magnetic clutch. (Refer to Figure 14-24.) The condenser is installed in the left nacelle aft of the firewall, between stations 78.00 and 98.00. The condenser scoop is mounted to allow extension into the airstream during system operation and is electrically activated.

The system is protected by a pressure switch which automatically controls the condenser maximum head pressures by temporarily de-clutching the compressor in the event the pressure becomes excessively high. Controls for operating the air conditioning system are located on the instrument panel just to the right of the copilot's control column. Two switches, an air condition ON-OFF control and three position (LOW-OFF-HIGH) fan switch, and a radial thermostat make up the controls.

The system design is such that there is no increase in drag to the aircraft during its take-off flight conditions. During maximum power demands the compressor is de-clutched and the condenser door is automatically retracted.

14-95. AIR CONDITIONING SYSTEM OPERATION. The air conditioning system in this airplane is a recirculating, independent unit. It filters, dehumidifies and cools the air as it cycles through the evaporator. From the controls as previously described, the system can be operated in two ways. (Refer to schematic Figure 11-49.) The fan (blower) switch, being the main power control switch to the system, can be operated solely to provide circulation at high or low blower, or in conjunction with the air conditioning ON-OFF switch, provide air conditioning at high or low blower. It is important to note that the "FAN" switch must be in low or high to provide power to the "Air Conditioning ON-OFF" switch and the rest of the system. A thermostatic switch is also provided to control temperature.

The air conditioning system uses Refrigerant 12 as the refrigerant. The refrigerant enters the compressor as a vapor. The compressor pressurizes the heat-laden vapor until its pressure and heat reach a point much hotter than the outside air. The compressor then pumps the vapor to the condenser where it cools and changes to a liquid. The liquid then passes to the receiver-dehydrator. Its function is to filter, remove any moisture and insure a steady flow of liquid refrigerant into the evaporator through the expansion valve. The expansion valve is a temperature controlled metering valve which regulates the flow of the liquid refrigerant to the evaporator. The evaporator absorbs the heat from the air passing over the coils. From the evaporator the refrigerant vapor returns to the compressor where the cycle is repeated.

NOTE

A table at the end of these instructions will assist in locating and correcting malfunctions which may arise in this system.

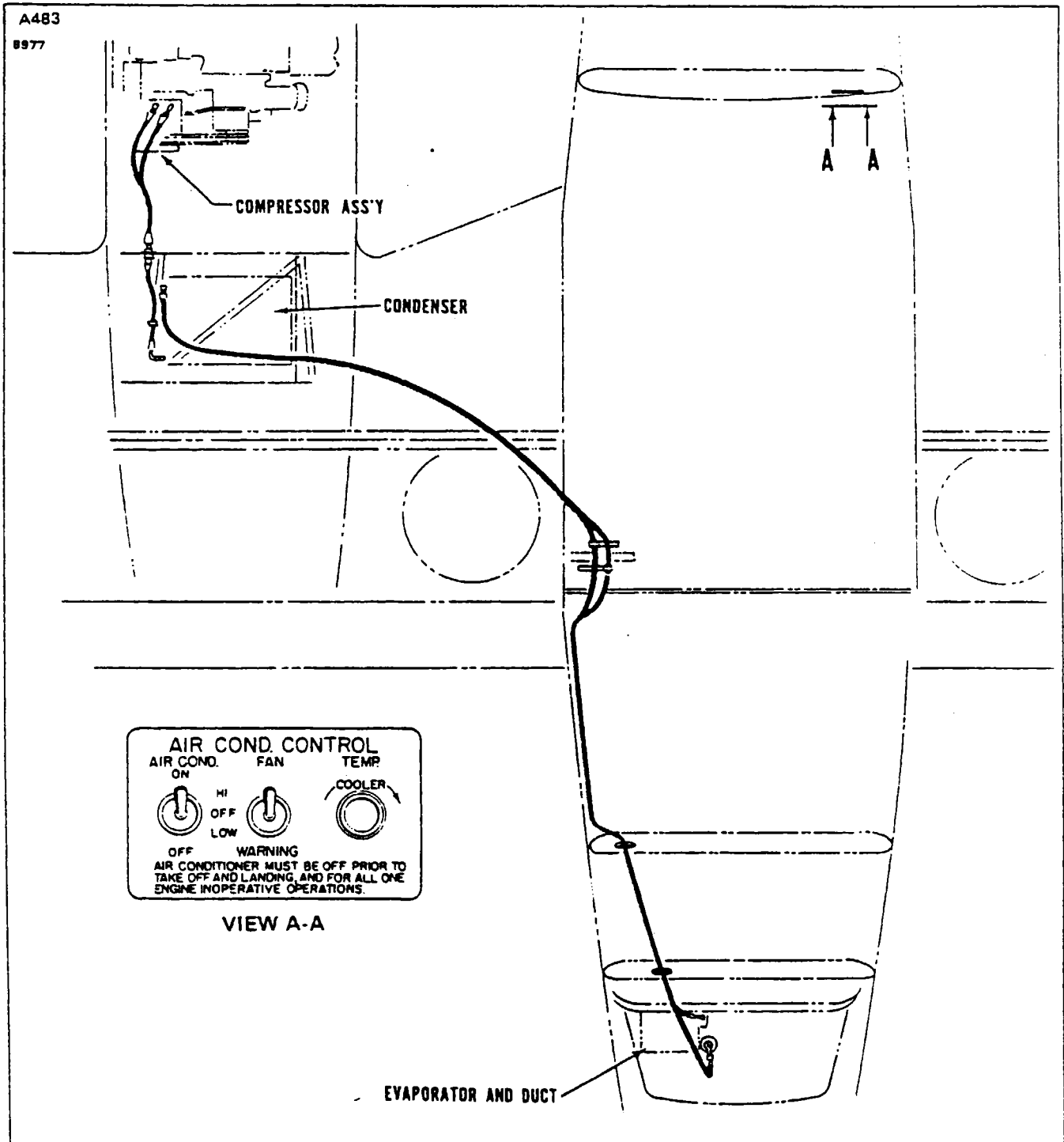

Figure 14-24. Air Conditioning System Installation

TABLE XIV-X. TEMPERATURE PRESSURE CHART

Evaporator Pressure Gauge Reading p.s.i.	Evaporator Temperature °F.	High Pressure Gauge Reading p.s.i.	Ambient Temperature °F.
0	-21	72	40
2.4	-15	86	50
4.5	-10	105	60
10.1	2	109	62
11.2	4	113	64
12.3	6	117	66
13.4	8	122	68
14.6	10	126	70
15.8	12	129	71
17.1	14	132	72
18.3	16	134	73
19.7	18	137	74
21	20	140	75
22.4	22	144	76
23.1	23	148	77
23.8	24	152	78
24.6	25	156	79
25.3	26	160	80
26.1	27	162	81
26.8	28	165	82
27.6	29	167	83
28.4	30	170	84
29.2	31	172	85
30	32	175	86
30.9	33	177	87
31.7	34	180	88
32.5	35	182	89
33.4	36	185	90
34.3	37	187	91
35.1	38	189	92
36	39	191	93
36.9	40	193	94
37.9	41	195	95
38.8	42	200	96
39.7	43	205	97
41.7	45	210	98
43.6	47	215	99
45.6	49	220	100
48.7	52	228	102
49.8	53	236	104
55.4	57	260	110
60	62	275	115
64.9	66	290	120

Reissued: 10/11/79

3D1

ACCESSORIES AND UTILITIES

PIPER SENECA II SERVICE MANUAL

NOTE

The air conditioning system should be operated at least once a month to prevent sticking valves and keep the system lubricated.

14-96. **MALFUNCTION DETECTION.** The detection of system malfunction largely depends on the mechanic's ability to interpret the gauge pressure readings into system problems. A system operating normally will have a low side gauge pressure reading that will correspond with the temperature of the refrigerant evaporating in the evaporator, allowing for a few degrees temperature rise due to loss in the tube walls and fins. The high side will have a gauge pressure that will correspond with the temperature of the refrigerant condensing in the condenser, allowing for a few degrees temperature drop due to loss in the tube walls and fins.

Any deviation from that which is normal indicates a malfunction within the system due to a faulty control device, obstruction, defective part, or improper installation.

Detection of system malfunction is made easier with the knowledge that the temperature and pressure of Refrigerant 12 is in close proximity between the pressures of twenty and eighty pounds per square inch (psi). A glance at the temperature-pressure chart will show that there is only a slight variation between the temperature and pressure of the refrigerant in the lower range.

It is correct to assume that for every pound of pressure added to the low side, a temperature increase of about one degree Fahrenheit takes place. For instance, a pressure of 23.8 on the chart indicates a temperature of 24°F. A change of pressure of almost one pound to 24.6 psi gives us a temperature increase to 25°F.

NOTE

For each 1,000 feet of elevation above sea level, the gauge readings will be about one inch of mercury or 1/2 psi higher than the chart indicates.

It must be pointed out that the actual temperature of the air passing over the coils of the evaporator will be several degrees warmer allowing for a temperature rise caused by the loss in the fins and tubing of the evaporator.

The importance of a seasonal check up of the air conditioning system should be brought to the attention of the customer whenever possible. A thorough check of the system performed in a methodical manner will reveal trouble the customer is often not aware of. Locating and repairing the trouble early will usually result in savings to the customer both in time and additional troubles that too often result from neglect.

A Performance Test of the system is the only positive way in which the complete system can be checked for efficient operation. The air conditioning system should be given this test before work is begun on the system whenever possible, however, if the system is completely inoperative, repairs must be performed before the system can be properly tested. The test can uncover further work that must be performed before the system is brought to its full operating efficiency. The Performance Test should always be performed after repair work has been done and before the aircraft is released to the customer. The serviceman performing this test carefully will insure that the repairs have been properly performed and that the system will operate satisfactorily.

The Performance Test when properly performed includes a thorough examination of the outside of the system as well as the inside. Many related parts are overlooked because it is felt they are of no bearing on the operating efficiency of the unit. For this reason, a thorough visual inspection of the complete system should be performed, followed by an operating inspection of the system.

14-97. SPECIAL SERVICING PROCEDURES. The air conditioning system should be serviced by a qualified shop with trained personnel. The following procedures and precautions should be observed.

The efficiency of this system depends upon the pressure-temperature relationship of pure refrigerant. As long as the system contains only pure refrigerant plus a specified amount of compressor oil (which is mixed with the refrigerant), it is considered to be chemically stable. Foreign materials within the system will affect the chemical stability, contaminate the system, and decrease its efficiency.

I. GENERAL REFRIGERATION SYSTEM PROCEDURES.

A. REFRIGERANT SAFETY PRECAUTIONS.

1. Refrigerant 12 (commonly known as R-12 or "Freon" 12) is odorless and colorless in either the liquid or gaseous state. R-12 for charging refrigeration systems is supplied in pressurized containers (approx. 70 psi at 70°F) in liquid form. Since this material is essentially inert at room temperatures the dangers are primarily associated with the pressure and the refrigeration effects of the release and subsequent evaporation of this pressurized liquid.
2. Wear suitable eye protection when handling R-12 due to the possibility of freezing of the eye if contacted by escaping liquid refrigerant. If liquid R-12 does strike the eye, the following actions should be taken:
 - a. DO NOT RUB THE EYE.
 - b. Splash large quantities of cool water into the eye to raise the temperature.
 - c. Tape on an eye patch to avoid the possibility of dirt entering the eye.
 - d. Rush to a physician or hospital for immediate professional aid.
 - e. DO NOT ATTEMPT TO TREAT IT YOURSELF.
3. If liquid R-12 strikes the skin frostbite can occur. Treat with cool water and protect with petroleum jelly.
4. Do not discharge large quantities of R-12 into closed rooms. It may displace most of the air in the room and this could cause oxygen starvation. Gaseous R-12 is heavier than air and flows to the bottom of a container.
5. Do not discharge R-12 into an open flame or onto a very hot surface (500°F+). Poisonous phosgene gas is generated by the action of the heat on the refrigerant.
6. Do not apply direct flame or other high heat source to a R-12 container due to the high pressures which will result. If any heating is done to R-12 containers the container pressure should be monitored and kept below 150 psi.

B. SYSTEM SERVICING PRECAUTIONS.

1. Systems should be discharged slowly to prevent the escape of liquid refrigerant and the loss of the lubricating oil.
2. Systems should not be left open to the atmosphere when discharged. Moisture and other contamination may enter and damage open systems.
3. Never introduce anything but pure refrigerant and refrigerant oil into a system.
4. Keep refrigerant oil containers tightly sealed and clean to prevent absorption of moisture or other contamination.
5. Use only approved refrigeration oil in the compressor. If any doubt exists about the cleanliness of the compressor oil, replace it with new oil.
6. Never reuse oil removed from the system. Discard it.
7. When Loctite Refrigerant Sealant has been used on a joint it must be heated to 400°F prior to disassembly. Loctite must be used to seal any pipe threads in the system lines.
8. Replace the receiver-dehydrator assembly on any system which has been operating with a leak allowing air to enter the system. If a receiver-dehydrator is left open to the atmosphere it should be replaced due to the loss of effectiveness of the drying compound it contains.

PIPER SENECA II SERVICE MANUAL

NOTE

A very strong acid (HCL) is formed when R-12 comes in contact with moisture.

A new receiver-dehydrator should be opened and connected to the system only when ready to charge the system with refrigerant.

9. Recommended torque values must be used on all flare fitting and O-ring joints. See Table XIV-XI.

TABLE XIV—XI. ALUMINUM TUBING TORQUE

Metal Tube O.D.	Thread and Fitting Size	Alum. Tubing Torque
1/4	7/16	5-7 ft.-lbs.
3/8	5/8	11-13 ft.-lbs.
1/2	3/4	15-20 ft.-lbs.
5/8	7/8	21-27 ft.-lbs.
3/4	1-1/16	28-33 ft.-lbs.

14.98. SERVICE VALVES. The purpose of the service valve is to service the air conditioning system. (Testing, Bleeding, Evacuating and Charging). This aircraft is equipped with service valves mounted in the suction and discharge lines of the evaporator assembly. These valves are the "2" position type Schrader valves. All normal air conditioning service should be performed at the evaporator assembly mounted valves.

NOTE

Service valves are also located on the compressor. However, use of these valves in servicing is not recommended.

NOTE

If a Schrader service valve is not serviceable, the core assembly must be replaced.

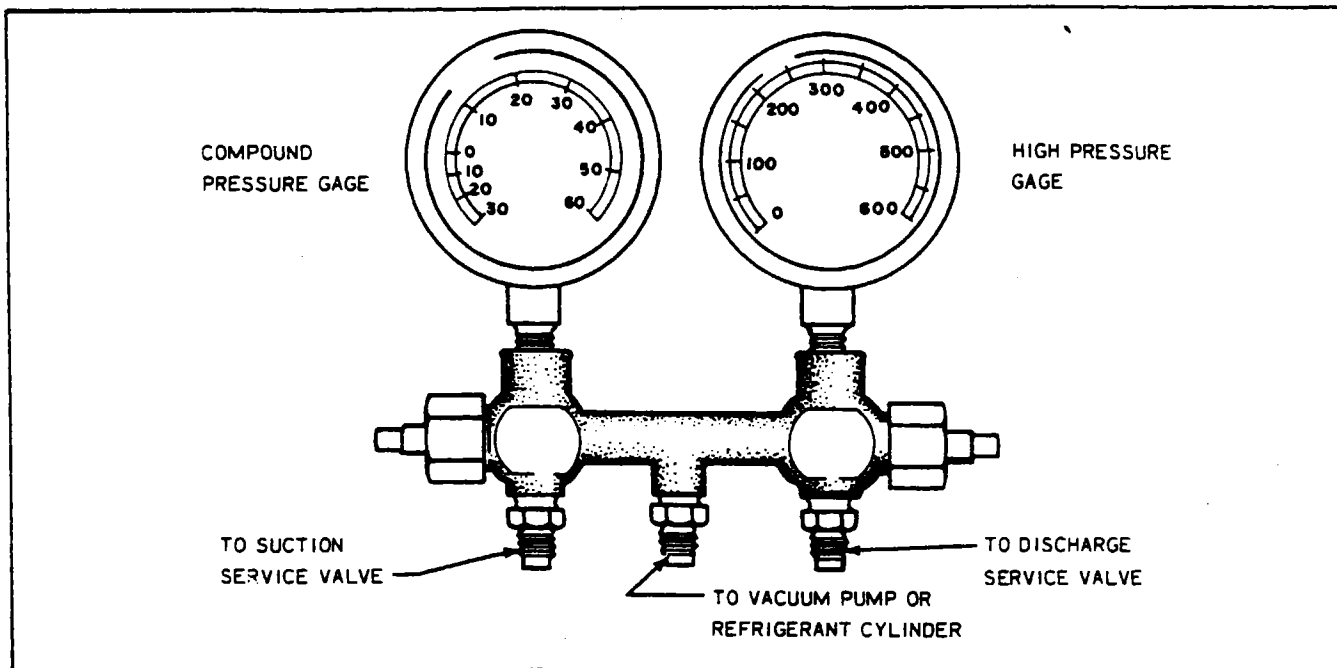

Figure 14-25. Test Gauge and Manifold Set

14-99. TEST GAUGE AND MANIFOLD SET. The proper testing and diagnosis of the air conditioning system require that a manifold gauge set be attached into the system. This set consists of two gauges mounted to a manifold. One gauge is a high pressure gauge used in the discharge side of the system. The other is a low pressure gauge used in the suction side of the system. The manifold is a device having fittings for both gauges and connection hoses with provisions for controlling the flow of refrigerant through the manifold. See Figures 14-25 and 14-26.

The center port of the manifold set is used for charging or evacuation procedures, or any other service that may be necessary.

Both the high and low side of the manifold have hand shut-off valves. When the hand valve is turned all the way in, in a clockwise direction, the manifold is closed. The pressures on the side of the system will, however, be recorded on the gauge above the hose.

Cracking the hand valve, in the counterclockwise direction, opens the system to the middle service port of the manifold set. This is desirable only when it is necessary to let refrigerant out or into the system. Refer to Figure 14-25 and 14-26.

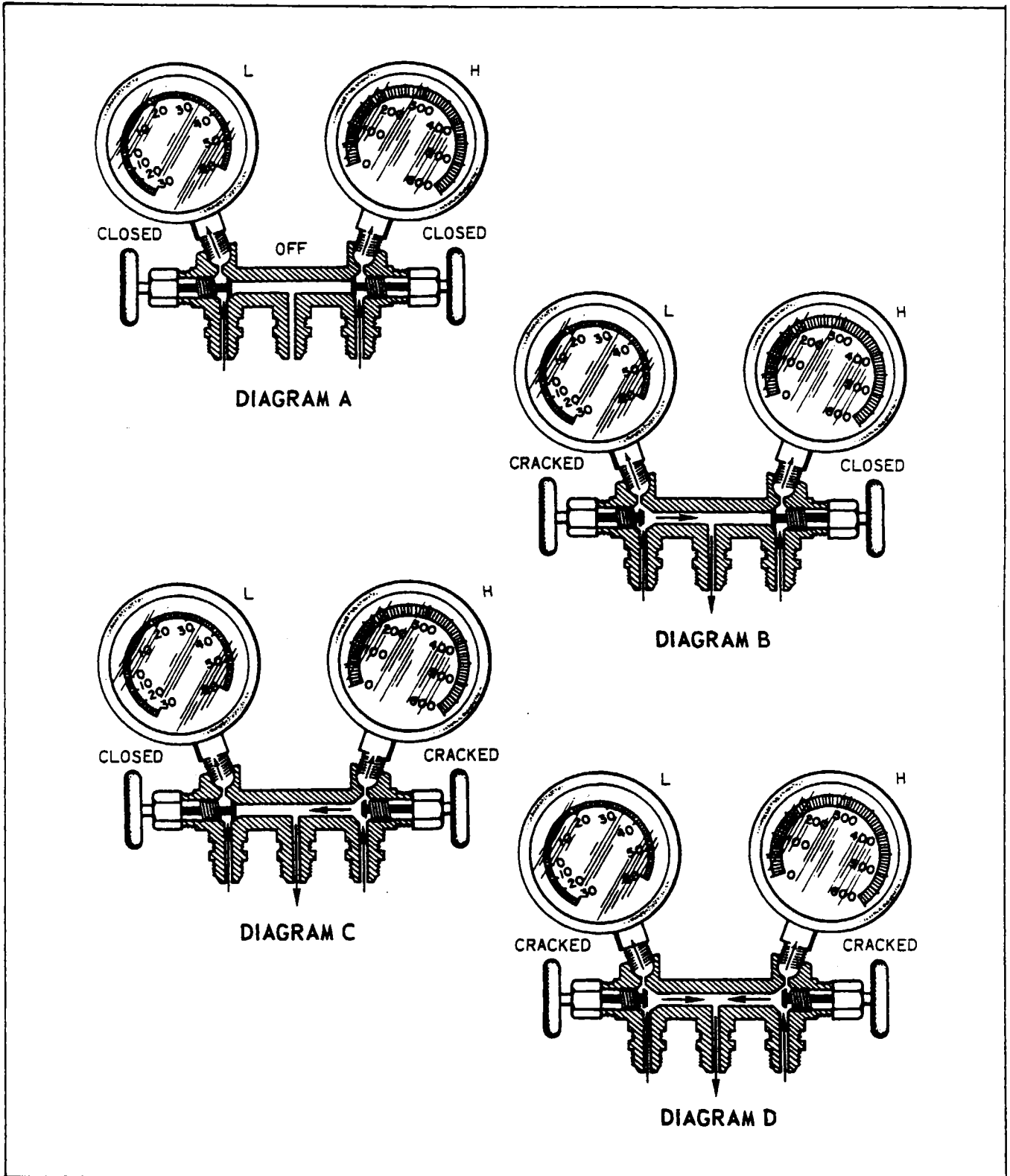

Figure 14-26. Manifold Set Operation

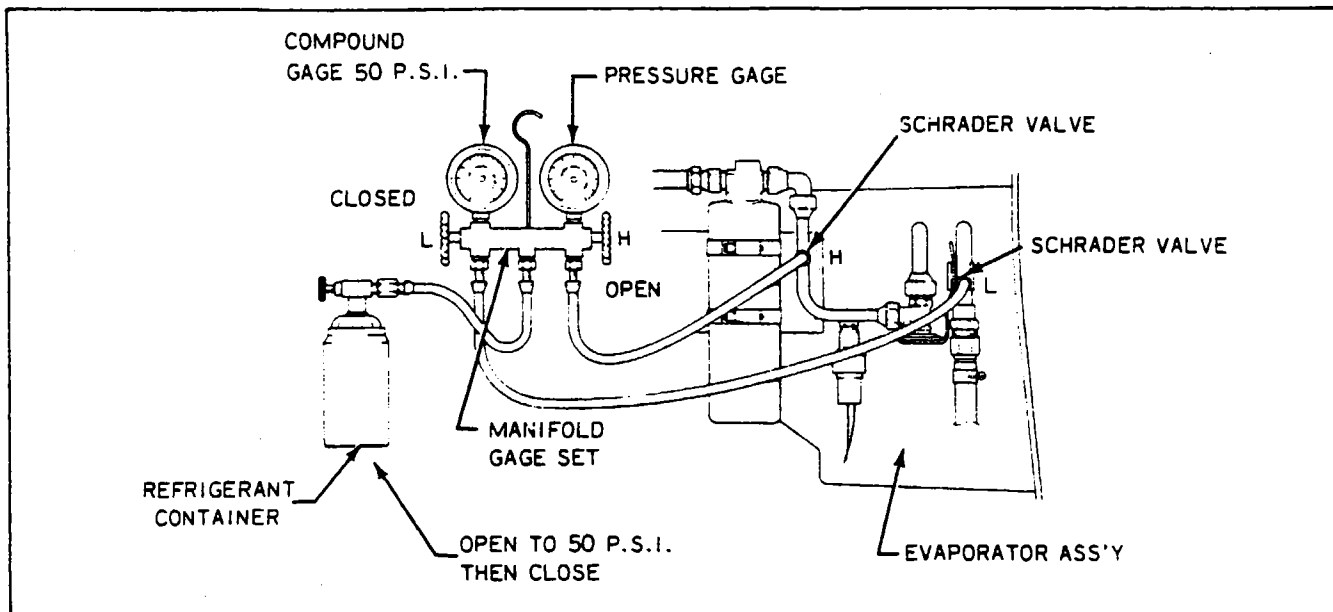

Figure 14-27. Leak Test Hookup

14-100. CHECKING THE SYSTEM FOR LEAKS. There are several methods of doing this operation, depending on the type of equipment which is available. Two methods of performing this check will be covered in the following paragraphs.

NOTE

Evacuate system prior to leak check.

14-101. LEAK CHECK - METHOD I.

- a. Connect the manifold gauge set into the system and determine if there is any refrigerant in the system. A minimum of 50 psi refrigerant pressure in the system is needed for leak detection. (Refer to Figure 14-27.)
- b. Purge the hoses of air by allowing some refrigerant to escape from the connections at the service valves. Then tighten connections at the service valve.
- c. Close the low side manifold valve and open the high side manifold valve.
- d. Open the refrigerant container service valve and allow the pressure at the low side gauge to reach 50 psi at which time close the high side manifold valve.
- e. Close the refrigerant container service valve and remove the hose if no leaks are evident.
- f. It is advisable to use an electronic leak detector to check this system instead of an open flame leak detector due to the possible presence of gasoline fumes in the engine area.
- g. If any leaks are found, purge the system of refrigerant, make the necessary repairs and check the compressor oil.
- h. Add oil, if required, (Refer to Paragraph 14-112 and Table XIV-XI) then repeat Steps a thru e.
- i. If no further leaks are found, the system may be evacuated and charged. Refer to Paragraphs 14-104 and 14-105.

14-102. LEAK CHECK - METHOD II.

- a. Remove the access panel at the rear of the cabin to gain access to the service valves.
- b. Remove the protective cap on the high pressure Schrader valve fitting and connect a charging hose with a shut-off valve arrangement to the fitting. The charging hose must have a Schrader fitting or adapter to fit the valve.
- c. Connect the other end of the charging hose to a small cylinder of refrigerant and purge the hose by allowing a slight amount of refrigerant gas to escape from the Schrader valve fitting.
- d. The cylinder of refrigerant should be placed upright in a container of warm (125° F max.) water on a small scale.
- e. Allow approximately 1/2 pound of refrigerant to enter the system by opening the valve on the charging hose and observing the weight change on the scale.
- f. Using an electronic leak detector, check all joints and repair any leaks.
- g. After completion of repair of any leaks, proceed to check the system in accordance with one of the methods outlined for any other leaks.
- h. If no further repair is required on the system, it is now ready to evacuate in accordance with Paragraph 14-104.

14-103. DISCHARGING.(Required only if system contains refrigerant.)

NOTE

Applies to Kent Moore J23500 or similar charging station. Refer to Figure 14-29.

- a. Close all valves on charging station.
- b. Connect red high pressure charging line to high pressure Schrader valve at the evaporator fitting.
- c. Open valve 8 (high pressure control) on charging station one turn.
- d. Hold end of blue low pressure charging line in a shop rag and slowly open valve 2 (low pressure control) on charging station allowing refrigerant to exhaust from system into shop rag.

CAUTION

Refrigerant can cause freezing of skin. Be particularly careful not to allow contact with the eyes.

Do not allow refrigerant to escape too rapidly, as excessive oil may be carried out of system. When hissing stops, system is empty and valve should be closed if no further work is planned.

14-104. EVACUATING THE SYSTEM.If the system has been operated in a discharged condition or anytime the system has been open to atmospheric pressure, the receiver-dehydrator must be replaced and the system evacuated to remove any trapped air and moisture which has entered it. A vacuum pump capable of pulling 29 inches of mercury or better should be used. As we lower the pressure in the air conditioning system, we lower the boiling temperature of the water (moisture) that may be present. Then we are able to pull this water, in the form of vapor, out of the system. The following table demonstrates the effectiveness of moisture removal under a given vacuum.

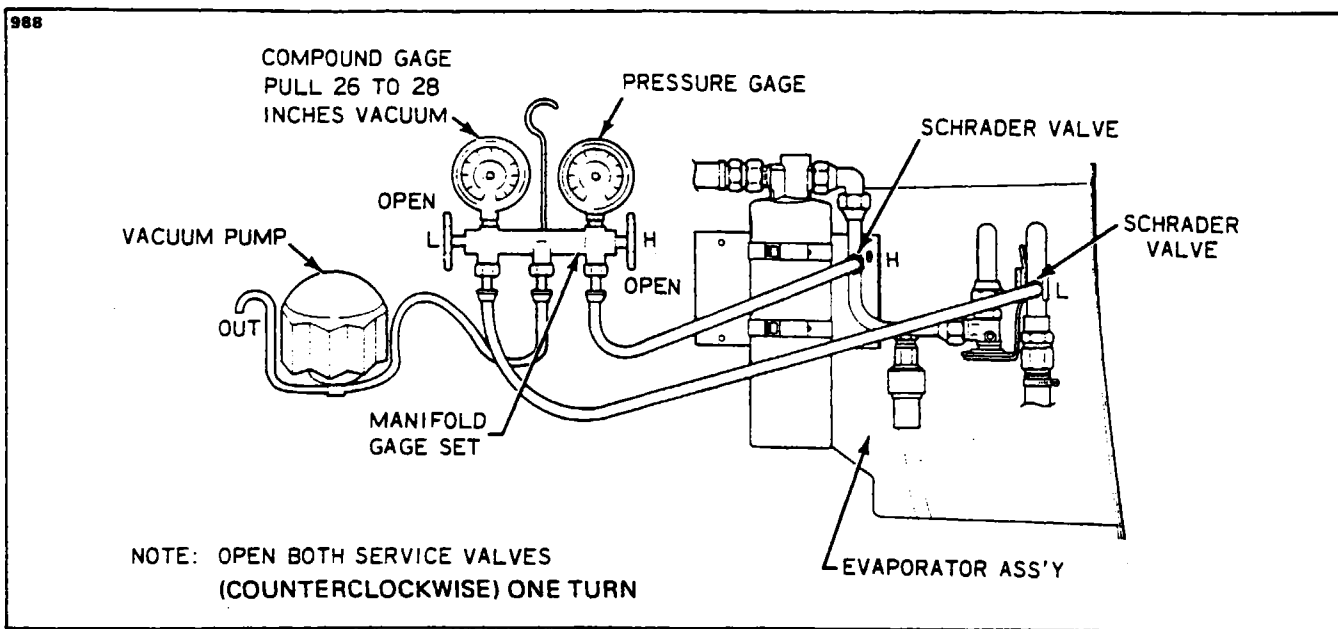

Figure 14-28. Evacuation Hookup

	System Vacuum	Temperature °F.
COMPOUND GAUGE READING IN INCHES OF MERCURY VACUUM	27.99	100
	28.89	80
	29.40	60
	29.71	40
	29.82	20
	29.88	0

NOTE

For each 1,000 feet of elevation above sea level, the compound gauge reading will be about one inch lower, numerically.

The following steps should be of help when performing this operation.

- a. Remove access panel at the rear of the cabin to gain access to the Schrader service valves.

CAUTION

Ascertain that all system pressure is released before attempting the evacuation. (Refer to Paragraph 14-97.)

PIPER SENECA II SERVICE MANUAL

- b. Connect the manifold gauge set to the airplane service valves. (Refer to Figure 14-28.)
- c. The high and low manifold hand valves should be in the closed position. (Refer to Figures 14-25 and 14-26.)
- d. Connect the center manifold hose to the inlet of the vacuum pump.

NOTE

Make sure the exhaust port on the vacuum pump is open to avoid damage to the vacuum pump.

- e. Start the vacuum pump and open the low side manifold hand valve. Observe the compound, low pressure gauge needle, it should show a slight vacuum.
- f. Continue to operate the vacuum pump until 26 to 28 inches of vacuum is attained on the low pressure gauge, then extend the operation for another 25 minutes.
- g. If the system cannot maintain 26 to 28 inches of vacuum, close both manifold hand valves and observe the compound gauge.
- h. Should the compound gauge show a loss of vacuum, there is a leak in the system which must be repaired before continuing with evacuation.
- i. If no leaks are evident, reopen both manifold hand valves and continue the evacuation for another 30 minutes.
- j. Close both manifold hand valves, stop vacuum pump and disconnect center manifold hose from the vacuum pump.
- k. Proceed to charge the system in accordance with Paragraph 14-105.

NOTE

The system should be charged as soon as it has been evacuated.

14-105. CHARGING THE SYSTEM. When the system is completely evacuated in accordance with instructions given in Paragraph 14-104, one of the following procedures should be used to charge the system.

14-106. WITH A CHARGING STAND. This is the preferred method of charging the system.

NOTE

The following instructions apply to Kent Moore, J23500 charging stand. Refer to Figure 14-29.

- a. With the system discharged and evacuated, proceed to hook-up the charging stand. (Refer to Figure 14-30.)
- b. Fill the charging cylinder by opening the valve at the base of the charging cylinder and filling the sight glass with two pounds of liquid refrigerant.
- c. As refrigerant stops filling the sight glass, open the valve at the top of the gauge neck assembly intermittently to relieve head pressure and allow refrigerant to continue filling the sight glass to the required amount.
- d. When refrigerant reaches the required level in the sight glass, close both the valve at the base of the cylinder and the valve at the bottom of refrigerant tank. Be sure the top valve is fully closed.

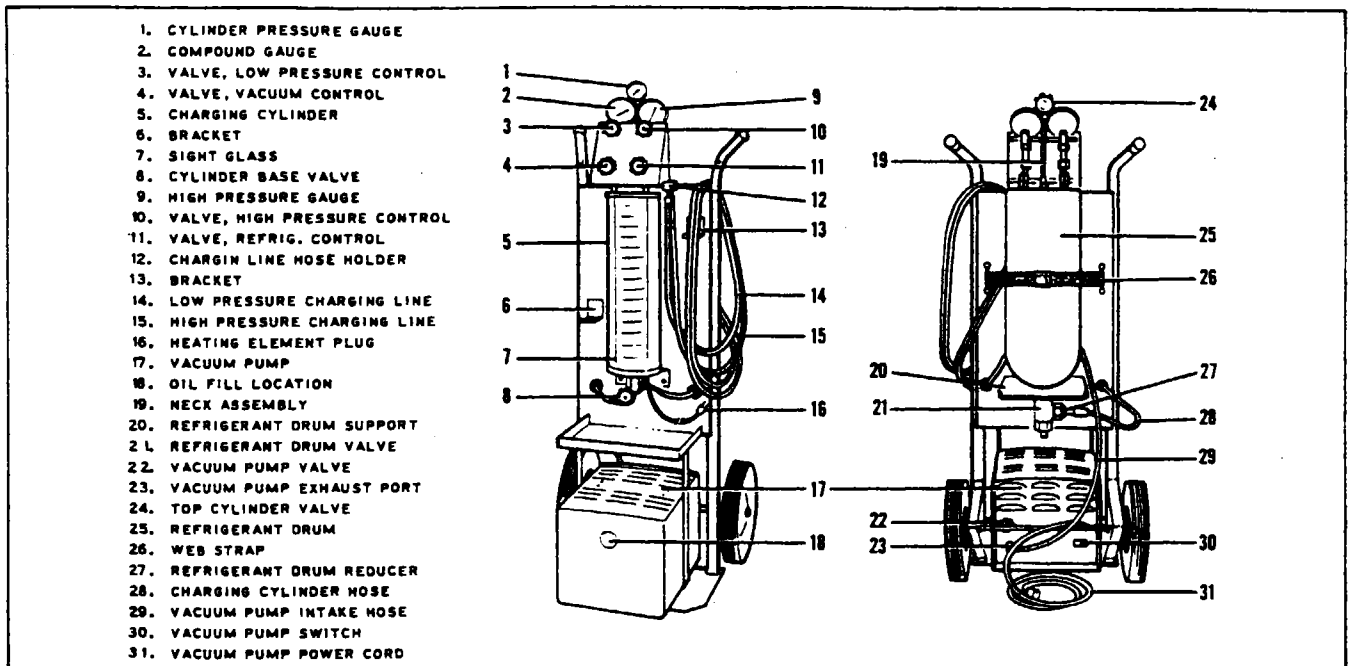

Figure 14-29. Charging Stand

NOTE

If bubbling occurs in sight glass, reopen the cylinder base valve momentarily to equalize drum and cylinder pressure.

- e. Connect the heating element plug to a 110 volt outlet.
- f. Turn cylinder sight glass to match pressure reading on cylinder pressure gauge. This scale should be used during entire charging operation.
- g. Close valve 1 (low pressure control), fully open valve 4 (refrigerant control) and allow all the liquid refrigerant contained in the charging cylinder to enter high side of aircraft system.
- h. When the full charge of refrigerant has entered the system, close valve 4 (refrigerant control) and valve 2 (high pressure control).
- i. After completion of charging, close all valves on the charging stand. Disconnect the high and low pressure charging lines from the aircraft system. (A small amount of refrigerant remaining in the lines will escape). Replace lines on holder of charging stand to keep air and dirt out of lines. Open the valve at the top of cylinder to relieve any remaining pressure, then reclose the valve.
- j. Reinstall protective caps of Schrader valves and any access panels previously removed.

14-107. USING THE AIRPLANE COMPRESSOR TO CHARGE THE SYSTEM. This method is the least desirable due to the requirement of operating the airplane's engine to run the compressor.

WARNING

If the airconditioner is to be operated during ground servicing, the test area should be clean and free of any loose objects lying on the ramp. Only the service valve located on the evaporator assembly should be used for testing.

PIPER SENECA II SERVICE MANUAL

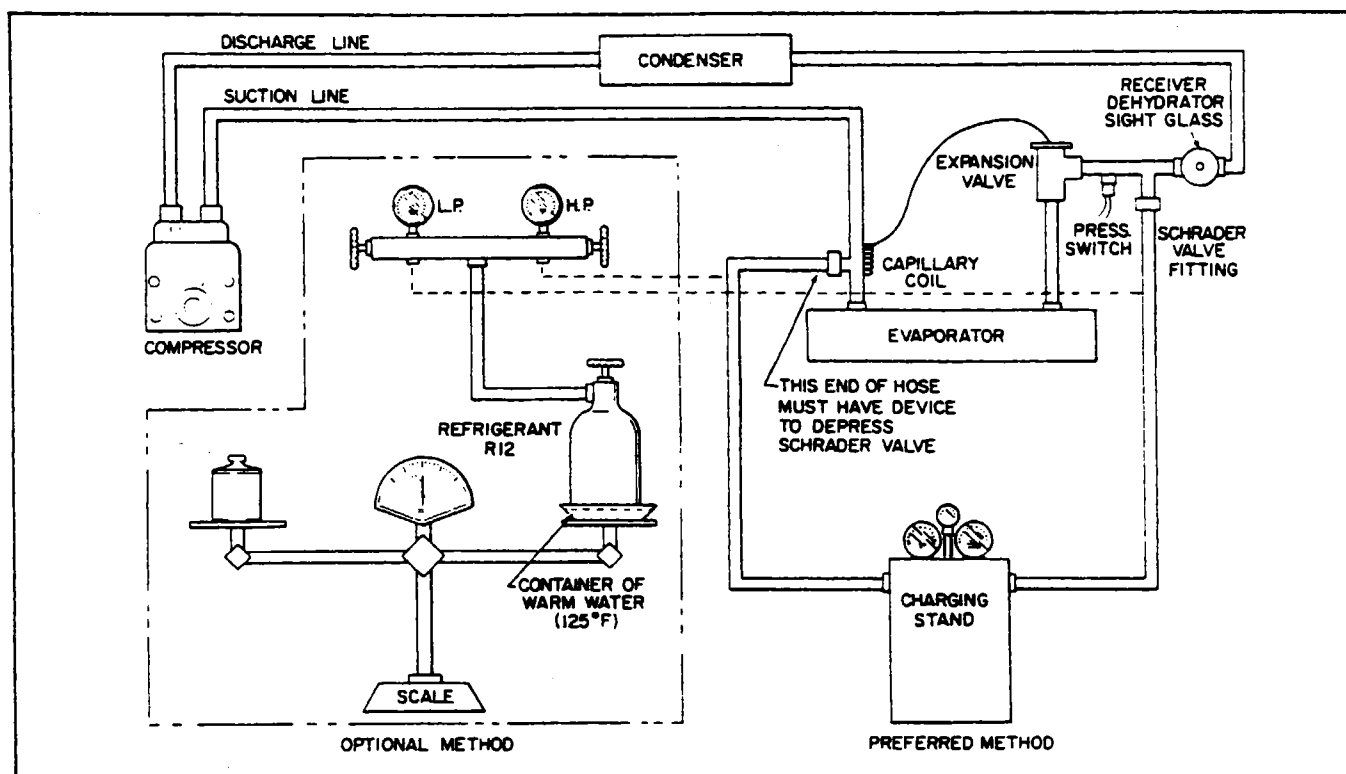

Figure 14-30. Charging Hookup

- a. With the system evacuated as outlined in Paragraph 14-104, connect the refrigerant charging hose to the manifold (refer to Figure 14-30) and purge the charging hose of air.
- b. Place the refrigerant container on a scale to observe the amount of refrigerant entering the system. Open the high pressure valve and add as much refrigerant as possible.
- c. Close the high pressure valve, start the engine and operate it at 900 to 1000 RPM.
- d. Operate the air conditioner and set controls to maximum cooling.
- e. Open the low pressure valve and complete charging the system.
- f. Close the low pressure valve after two pounds of refrigerant has been added to the system.
- g. With the system still operating, observe the sight glass in the top of the receiver-dehydrator by removing the plastic plug.
- h. The sight glass should be clear of any bubbles or foam. If bubbles or foam are seen passing through the sight glass, it is an indication of a low refrigerant charge in the system and more refrigerant is required. This check should be made with OAT of 70°F or higher and with the air conditioner operating.
- i. If more refrigerant must be added to the system, open the low pressure valve and increase engine speed to 2000 RPM and observe the sight glass. After the sight glass has cleared, close the low pressure valve and observe the pressure gauges. At 1000 RPM the gauge pressure should be 15 to 20 psi on the low side and 150 to 200 on the high side.

NOTE

Suspect leaks or an inaccurate scale if two pounds of refrigerant does not fill the system.

- j. Shut off the air conditioning system and airplane engine. Then, remove the charging lines from the Schrader valves with care due to the refrigerant remaining in the hose

NOTE

A shop cloth should be used to divert escaping refrigerant when disconnecting the charging hose from the Schrader valve. Recap the valve.

14-108. ADDITION OF PARTIAL CHARGE TO SYSTEM. It is possible to top off this system with refrigerant by the following method:

- a. Remove the access panel at the rear of the cabin.
- b. Connect a charging hose to a refrigerant cylinder and also to the Schrader valve fitting on the suction line. (Refer to Figure 14-30.)
- c. Purge the charging hose by allowing a small amount of refrigerant gas to escape at the Schrader valve fitting.
- d. Start the engine and operate at 1000 RPM and turn the air conditioner on maximum cool.
- e. Remove the plastic plug from the sight glass in the top of the receiver-dehydrator.
- f. With a low refrigerant charge in the system, bubbles will be seen passing thru the sight glass when the system is operating.
- g. Open the valve on the refrigerant cylinder.
- h. Allow refrigerant to flow into the system until the bubbles disappear from the sight glass.
- i. Close the refrigerant valve and check to see that the sight glass remains clear during system operation.
- j. When the sight glass stays clear of bubbles, add an additional 1/4 pound of refrigeran to the system. (Engine should be operating at 1000 RPM.)

NOTE

This should be done with OAT at 70° F, or higher, with the air conditioner operating.

- k. Shut off the air conditioner and engine. Remove the charging hose from the Schrader valve with care due to refrigerant remaining in the line.
 - l. Replace the access panels.

14-109. COMPRESSOR SERVICE. It is not advisable to service the compressor in the field. It should be done by a qualified shop which has the special equipment and trained personnel required to properly service the unit.

Maintenance to the Sankyo compressor is limited to replacement of worn drive belt. Contact Sankyo International, 10710 Sanden Dr., Dallas, Texas 75238 (214) 349-3030 for special tools and instructions for detailed compressor maintenance.

NOTE

An important factor in air conditioning servicing is cleanliness and care should be exercised to prevent dirt or foreign material from entering the system. All hose and tubing ends should be capped immediately. Any lubrication required in the assembly of the components should be refrigerant oil of the type used in the compressor.

14-110.COMPRESSOR REMOVAL. (The removal of the compressor requires a complete system discharge.) (See Paragraph 14-103.) The removal instructions for the Sankyo compressor are as follows:

- a. Ascertain that air conditioning circuit protector is in the off position.
- b. Remove engine cowling.
- c. Disconnect the electrical leads to the magnetic clutch on the compressor.
- d. Depressurize the air conditioning system.
- e. Remove the suction and discharge line from the service valves on the compressor.

NOTE

All open lines should be capped immediately to prevent dirt and moisture from entering the system.

- f. Loosen the four bolts securing the compressor in the mounting brackets. Rotate the compressor in the bracket slots to disconnect drive belt.
- g. Support compressor and remove the attachment bolts.

14-111.COMPRESSOR INSTALLATION. The installation instructions for the Sankyo compressor are as follows:

- a. Place the compressor in the mounting brackets and install attachment bolts. Do not torque attachment bolts at this time.
- b. Install compressor drive belt. Rotate compressor drive belt. Rotate compressor in mounting bracket slots to obtain a belt tension of 85 to 90 pounds. Torque the four attachment bolts 300 to 350 inch-pounds. (Refer to Paragraph 14-113.)
- c. Check the oil level in the compressor in accordance with instructions given in Paragraph 14-112.
- d. Connect the discharge and suction lines to their respective fittings.
- e. Evacuate and charge the system per Paragraphs 14-104 and 14-105.

WARNING

If the air conditioner is to be operated on the ground for servicing, the test area should be clean and free of any loose objects lying on the ramp. Only the service valves located on the evaporator assembly should be used for testing.

14-112.CHECK COMPRESSOR OIL. The oil level should be checked any time the system is discharged. Use the following instructions for checking Sankyo compressor oil level:

- a. Run the compressor for 10 minutes with engine at 1900 RPM.

WARNING

If the air conditioner is to be operated during ground servicing, the test area should be clean and free of any loose objects lying on the ramp. Only the service valve located on the evaporator assembly should be used for testing.

- b. Discharge the system per Paragraph 14-103; be careful not to lose any oil.
- c. Remove the oil fill plug.
- d. Position the rotor to top dead center (refer to Figure 14-31) by rotating the clutch front plate until the casting mark is visible in the center of the hole.

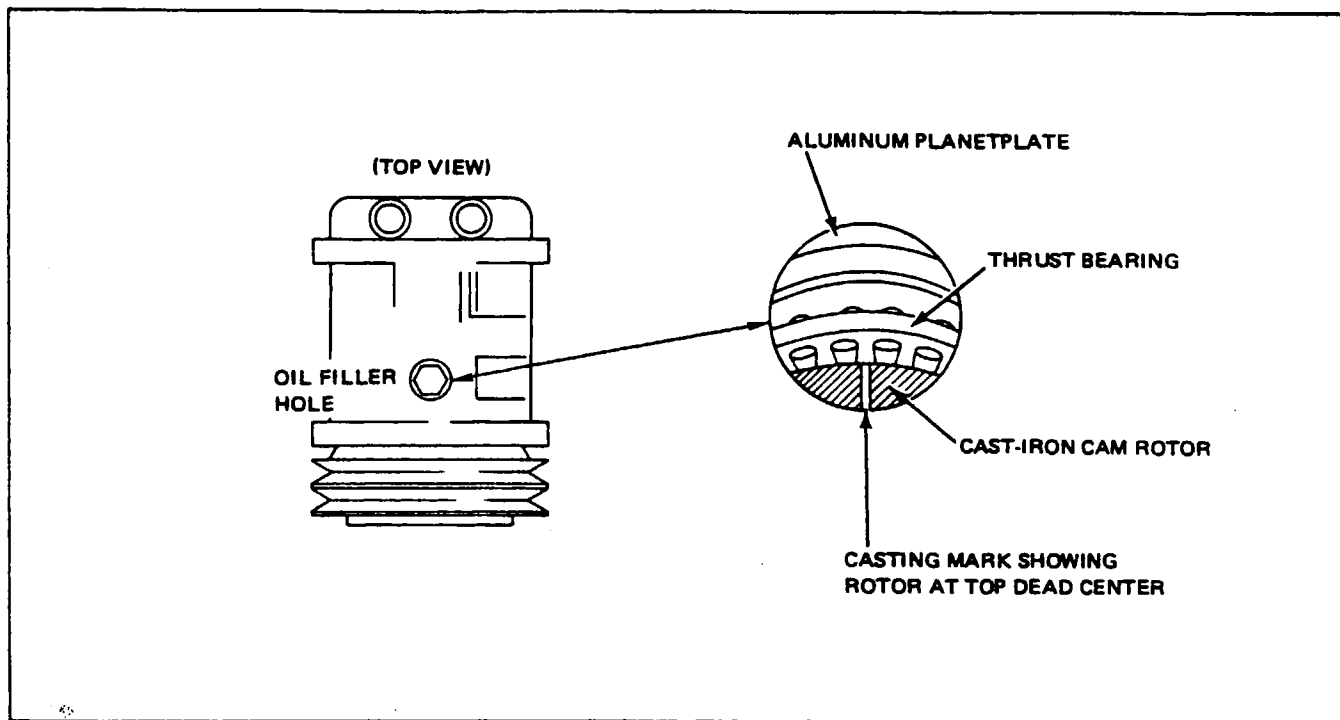

Figure 14-31. Top Dead Center Casting Mark (Sankyo Compressor)

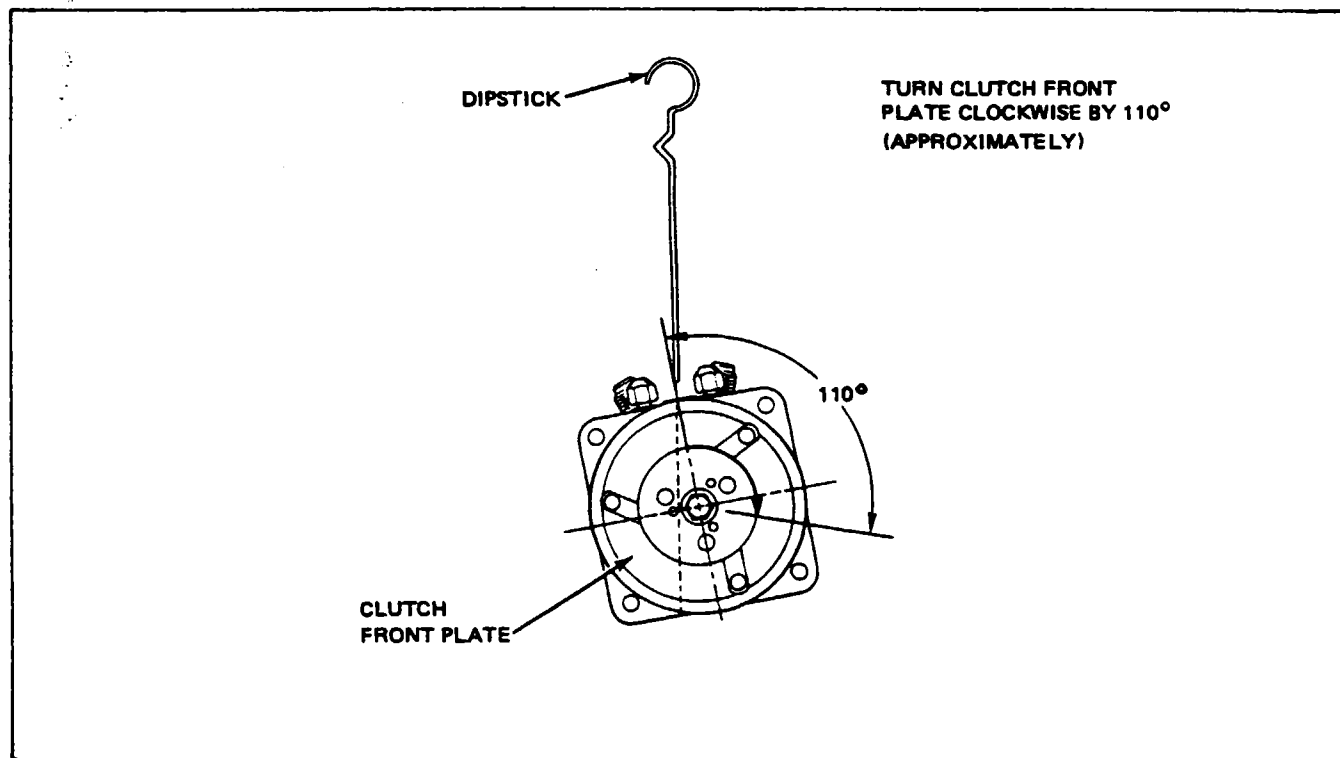

Figure 14-32. Rotation of Clutch Front Plate (Sankyo Compressor Oil Check)

PIPER SENECA II SERVICE MANUAL

- e. Rotate the clutch front plate clockwise by approximately 110°. (Refer to Figure 14-32.)
- f. Insert dipstick No. 32447 purchased from Sankyo. (See Paragraph 14-109 for Sankyo address.)
- g. Remove the dipstick and count the number of increments of oil. The acceptable oil level in increments is 7 to 10. This represents between 2.6 and 4.4 fluid ounces.
- h. When oil is added, refrigerant oil No. 9500 (Napa Temp Prod.), Sun Oil Suniso No. 5, Texaco Copella E or Copella E (Wax Free) or equivalent 500 viscosity refrigerant oil must be used.
- i. When installing the oil filler plug, make sure the sealing O-ring is not twisted and that no dirt or particles are on the O-ring or seat. Torque the plug to 6-9 foot-pounds. Do not overtighten the plug to stop a leak; remove the plug and install a new O-ring.
- j. Evacuate and charge the system. (Refer to Paragraphs 14-104 and 14-105.)

CAUTION

The oil plug should not be removed with pressure in the system.

14-113. ADJUSTMENT OF DRIVE BELT TENSION. Adjust the Sankyo compressor as follows:

- a. Rotate the compressor to obtain tension of 100 pounds for new belt or 85 to 90 pounds for old belt.
- b. Run the engine for a 15 minute period at 1900 RPM with the compressor engaged.

WARNING

If the air conditioner is to be operated during ground servicing, the test area should be clean and free of any loose objects lying on the ramp. Only the service valve located on the evaporator assembly should be used for testing.

- c. Shut down engine and recheck the belt tensions. New belt tension should fall back to desired tension of 85 to 90 pounds. Old belts reinstalled should retain the 85 to 90 pounds span tension.
- d. This tension check should be made at every 100 hours or annual inspection whichever occurs first.

14-114. REFRIGERANT LINES AND ROUTING. The refrigerant lines in this aircraft are flexible high pressure hoses and should be handled accordingly. The hoses in the power plant area are routed so as to provide maximum protection from heat and abrasion. They couple at the firewall to hoses routed through the two inboard, external hat section on the bottom of the fuselage, up through the floor to the condenser and evaporator in the tail cone. The discharge is in the right hat section and the suction in the left.

NOTE

Before any of the hose couplings are uncoupled, the system must be completely discharged. (See Paragraph 14-103.)

14-115. RECEIVER-DEHYDRATOR.

14-116. RECEIVER-DEHYDRATOR REMOVAL. This unit is mounted on the inboard side of the evaporator assembly housing.

- a. Discharge the system of all refrigerant. (See Paragraph 14-103.)
- b. Uncouple the refrigerant lines at the receiver-dehydrator. (See Paragraph 14-97. B-7.)

- c. Remove the clamp attaching the unit to the evaporator housing.

NOTE

This part is not serviceable, it must be replaced. The receiver-dehydrator should be replaced when the system has been operated without a charge or is left open.

14-117. RECEIVER-DEHYDRATOR INSTALLATION.

- a. Slip the mounting bracket around the receiver and put it in place on the evaporator housing with the tube fitting on top. Align the fittings to the proper line before securing the mounting bracket.

NOTE

Torque the fittings. (See Table XIV-XI.)

- b. Evacuate and recharge the system in accordance with Paragraphs 14-104 and 14-105.

14-118. CONDENSER. The condenser is located in the left nacelle aft of the firewall, between stations 78.00 and 98.00.

14-119. CONDENSER REMOVAL.

- a. Remove the hatch cover assembly.
- b. With the system completely discharged, disconnect the suction and discharge hoses at the condenser fitting. (See Paragraph 14-97, B-7.)

NOTE

Cap the open lines to prevent moisture and dust from contaminating the system.

- c. Remove the screws which hold the condenser to the mounting brackets.
- d. Remove the condenser from the nacelle, being careful not to bend the fins of the core or damage connecting tubes.

NOTE

Cap the lines till reinstalled.

14-120. CONDENSER INSTALLATION.

- a. Place the condenser in the left nacelle with the line connections on the outboard side.
- b. Attach the condenser to the mounting brackets.

NOTE

It is advisable to change the receiver-dehydrator whenever the system has been open to the atmosphere.

- c. Seal and couple the hose fittings. Apply a small amount of Loctite refrigerant sealant to the flare only to insure leak free connections.

PIPER SENECA II SERVICE MANUAL

- d. With the condenser secured, proceed to evacuate and recharge the system.
- e. When the system is completely charged, check it for any leaks.
- f. Replace and secure hatch cover assembly.

14-121. **CONDENSER SCOOP RIGGING INSTRUCTIONS.** (Refer to Figure 14-33.) The condenser assembly is actuated by an electric motor through bellcranks, push rods and limit switches. The scoop rigging instructions are as follows:

- a. Disconnect the actuating arm from the condenser scoop by removing the nut and bolt, that attaches the arm to the scoop.
- b. Remove the nut, washer and bolt, that attaches the actuating arm to the vent door.
- c. Place the air condition toggle switch in the off position. Apply power by turning the master switch to the on position.

CAUTION

Looking outboard the motor should drive the mechanism clockwise to the closed position. If the motor turns in the opposite direction, turn off power and check wiring.

- d. With the system in full closed (clockwise) position, the length of the actuator arms can be adjusted to hold the scoop and vent doors firmly closed.
- e. Connect the actuating arms to the scoop and vent door and secure with attachment hardware.
- f. The scoop can now be operated by turning the fan switch to the low or high position. The scoop and vent door opening dimensions can be checked by the following outlined procedure:
 - 1. Place the fan switch to the low or high position.
 - 2. Depress the air condition squat switch located on the right hand main gear.
 - 3. Place the air condition toggle switch to the on position. The scoop will then open to the flight position. The flight position should be adjusted to $.8 \pm .1$ inch. (Refer to Figure 14-33.)
 - 4. Release the air condition squat switch. The scoop will then open to the ground or full open position. The full open position should be adjusted to $2.00 \pm .10$ inches. (Refer to Figure 14-33.)
 - 5. Depress the air condition squat switch, the scoop will return to the flight position.
 - 6. Place the air condition toggle switch to the off position, the scoop will return to the closed position.

NOTE

If the scoop and vent doors do not open to the proper distance, adjustments may be accomplished by adjusting the ground and flight position limit switches. **DO NOT** bend the actuator arms to adjust.

- 7. Cycle scoop and vent doors to ensure proper operation, by turning the air condition toggle switch on and off.

NOTE

The squat switch must be depressed for the scoop to stop in the flight position.

- 8. Turn fan and air condition switches to the off position. The scoop and vent doors will then return to the closed position.
- 9. Turn off the master switch.

A487

1. CONDENSER SCOOP
2. VENT DOOR
3. ROD ASSEMBLY - SCOOP - 24.68"
4. ACTUATING ROD - CONDENSER SCOOP - 4.74"
5. ACTUATING ROD - VENT DOOR - 13.84"
6. LIMIT SWITCH - GROUND POSITION
7. LIMIT SWITCH - FLIGHT POSITION
8. LIMIT SWITCH - FLIGHT POSITION
9. LIMIT SWITCH - CLOSED POSITION
10. MOTOR
11. BEARING BLOCK

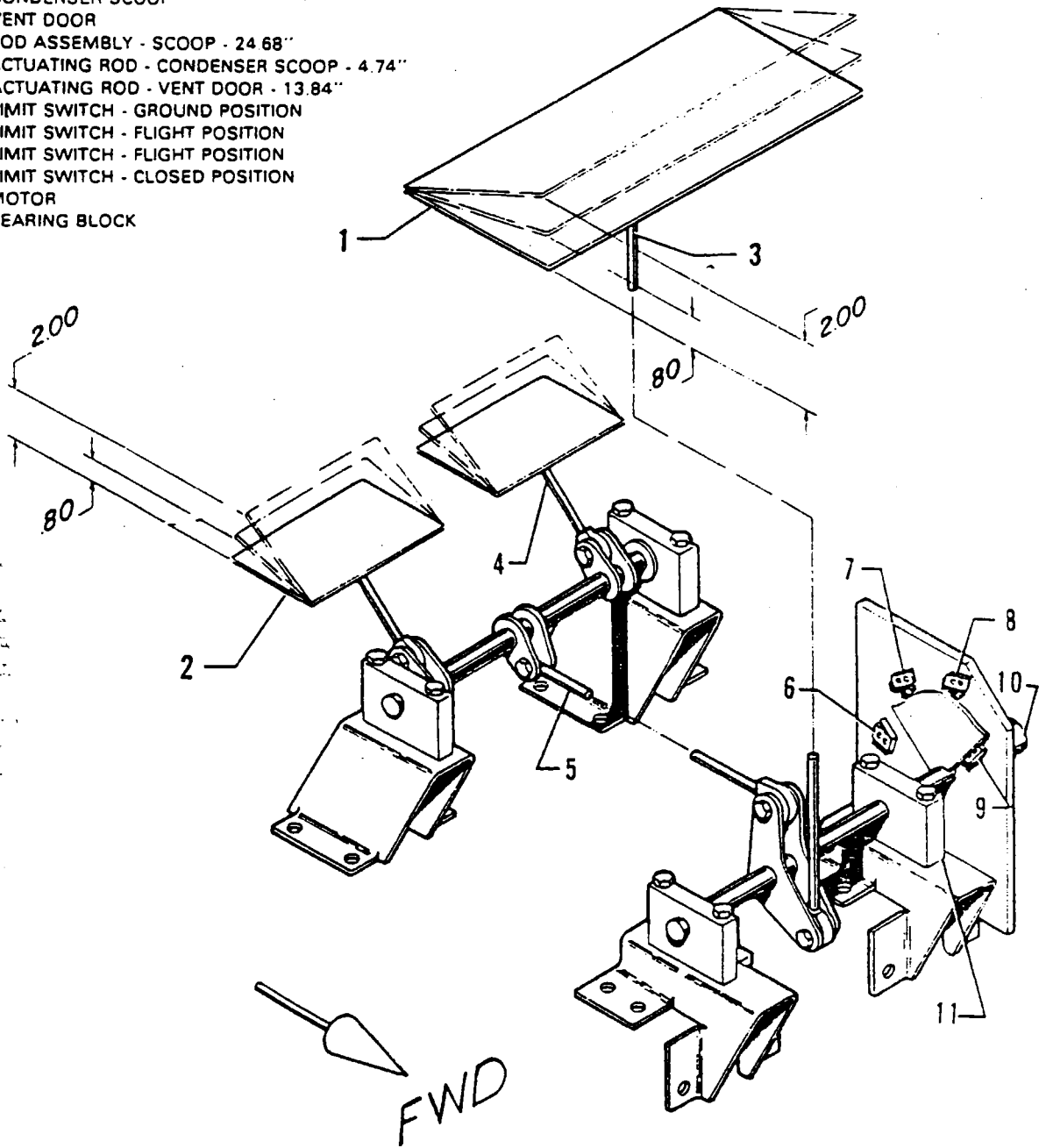

Figure 14-33. Condenser Air Scoop Installation

Revised: 8/10/80

3D19

ACCESSORIES AND UTILITIES

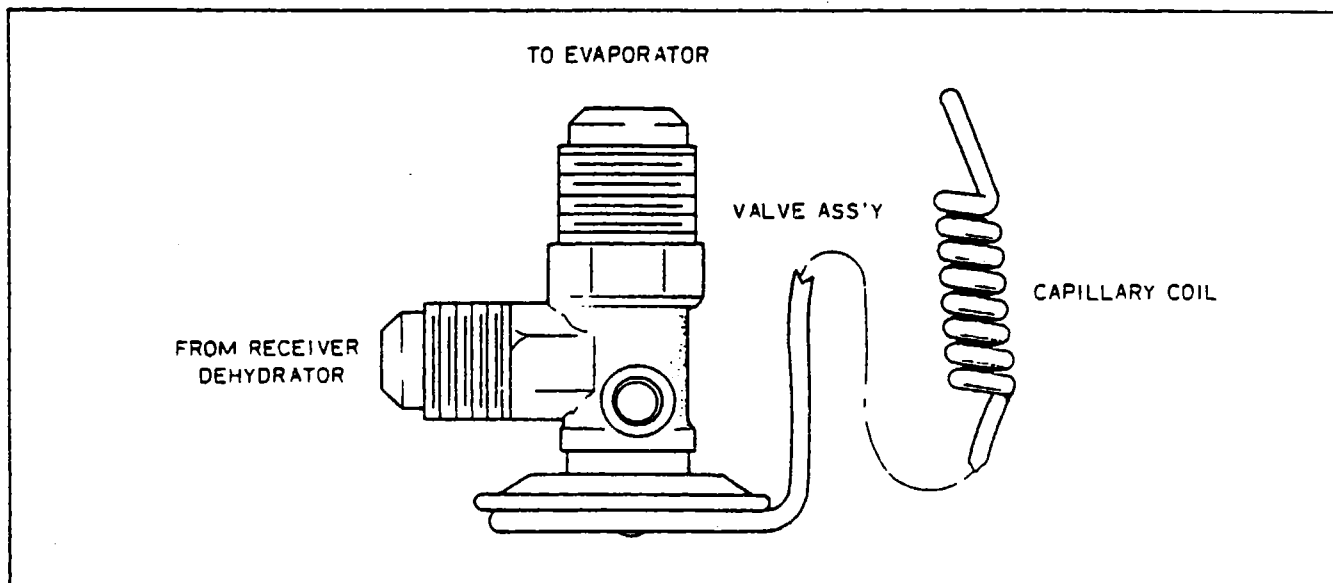

Figure 14-34. Expansion Valve

14-122. EXPANSION VALVE. (See Figure 14-34.)

14-123. EXPANSION VALVE REMOVAL. The expansion valve is located in the evaporator assembly between the receiver drier and the evaporator inlet. The capillary coil is attached to the evaporator outlet line.

- a. Remove the necessary access panels and discharge system.
- b. Remove the capillary coil from the outlet line. (Do not link the capillary tube.)
- c. Uncouple all related tube fittings. (See Paragraph 14-97, B-7.)

NOTE

If this part is not serviceable, it must be replaced with a new part.

14-124. EXPANSION VALVE INSTALLATION.

- a. Install the expansion valve in the inlet line of the evaporator core by coupling the related fittings. (Seal all couplings with sealant applied to tube flanges only.) Torque fittings per Table XIV-X.
- b. Secure the capillary coil to the evaporator outlet line.
- c. Evacuate and charge the system. (See Paragraphs 14-104 and 14-105.) Check for leaks. (See Paragraph 14-100.)
- d. Replace access panels.

14-125. EVAPORATOR ASSEMBLY. The evaporator assembly consists of the evaporator core, receiver-dehydrator, expansion valve, circulating fan and pressure switch together with necessary housing and plumbing. The housing is fabricated of Cylolac type material. The condensed moisture is dumped over board through a hose clamped to a fitting on the bottom of the evaporator housing.

14-126. EVAPORATOR ASSEMBLY REMOVAL. The evaporator assembly is located behind the cabin rear panel, attached to the mounting panel with 12 screws and washers and a bracket securing the back to the mounting panel.

- a. Remove air conditioning filter cover, filter and rear access panels.

NOTE

Discharge the system before disassembling. (Refer to Paragraph 14-34.)

- b. Uncouple the liquid line from the inlet side of the receiver-dehydrator and the suction line from the evaporator core outlet. (See Paragraph 14-97, B-7.)

- c. Disconnect the related electrical wires.

- d. Remove flexible air duct from housing outlet. Remove drain hose from housing.

- e. Remove temperature probe from evaporator housing.

- f. Remove the screws attaching the support bracket and evaporator housing to the mounting panel.

Remove the assembly through the access hole in the bulkhead.

14-127. EVAPORATOR ASSEMBLY INSTALLATION.

- a. Cement gasket in place on the flanges of the evaporator housing and attach the large end of the mounting gasket to the back of the housing.

- b. Install the housing through the access hole with the air duct outlet on top. Mate the mounting flanges to the mating surface of the mounting panel and insert the screws. (Do not tighten at this time.)

- c. Line up the mounting bracket with mating holes in mounting panel insert screws and tighten. Tighten screws in the flange at this time. Be certain gasket is in place. The flange must have an air tight seal.

- d. Couple the suction and discharge lines to their respective fittings (apply Loctite refrigerant sealant to tube flanges only).

- e. Evacuate and charge system. (See Paragraphs 14-104.)

- f. Check for leaks. (See Paragraph 14-100.) If no leaks are detected, seal and install access panel on evaporator housing.

- g. Couple flexible air duct and drain tube.

- h. Make and check electrical connections.

- i. Check operation of blower and refrigerant systems.

- j. Install rear bulkhead panels. Be certain to seal. (See WARNING.)

WARNING

Whenever it is necessary to remove and replace the cabin rear panel, it should be replaced and sealed in the original manner to prevent exhaust gases from entering the cabin. After removing and replacing the rear panel, conduct a carbon monoxide test on the ground and in flight with and without the air conditioner operating. Presence of CO shall not exceed one part in 20,000.

PIPER SENECA II SERVICE MANUAL

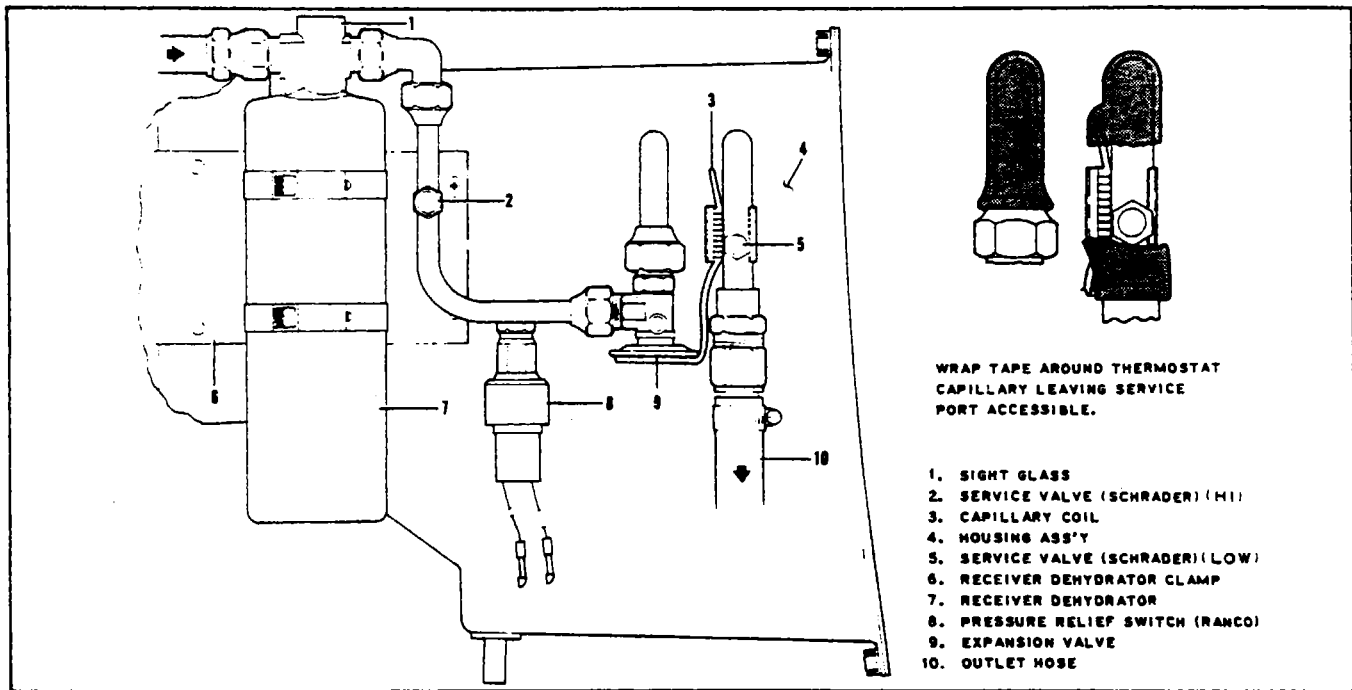

Figure 14-35. Components Installation

14-128. **PRESSURE RELIEF SWITCH (Texas Instruments).** The pressure relief switch automatically prevents the system from over pressurization by breaking the electrical circuit to the magnetic clutch, stopping the compressor until pressure is reduced. The switch is located in the line between the receiver and expansion valve, and set to cut out at 350 ± 10 psi and cut in at 250 ± 10 psi.

NOTE

Before the relief switch is removed, the air conditioning system must be discharged. (See Paragraph 14-34.)

14-129. **ELECTRICAL INSTALLATION.** The electrical system, routing and component are installed and routed in the conventional aircraft manner. The wiring harness is connected to switches in the climate control center on the right side of the instrument panel. The harnesses cross the instrument panel to the left side where two (2) wires are taken off for the compressor clutch. The harness then passes aft along the left side of the fuselage where it connects to the blower motor, pressure relief switch and the condenser actuating motor.

14-130. **FUSE REPLACEMENT.** There are three fuses located behind the air conditioning system control panel. A 20 amp circuit breaker mounted in the circuit breaker panel protects the complete air conditioning electrical system.

14-131. OVERHEAD VENT BLOWER

14-132. DESCRIPTION. The blower is mounted in the aft section of the fuselage and is connected to the overhead vent system. The blower draws air in from the dorsal fin and forces it through the ducting whenever desired. The four position blower switch is mounted in the overhead panel and controls the three speed blower.

14-133. REMOVAL OF BLOWER ASSEMBLY.

- a. Remove the access door from the aft wall of the baggage area.
- b. With the master switch off, disconnect the plug assemblies at the blower assembly.
- c. Remove the inlet and outlet hoses from the blower assembly by removing the clamps.
- d. Remove the screws, washers, and nuts that secure the blower assembly to the hanger braces.
- e. Remove the screws and washers which secure the blower assembly to the retainer and hangers.
- f. Remove the blower assembly from the aircraft.

14-134. DISASSEMBLY OF BLOWER ASSEMBLY.

- a. Remove the hose duct from the forward edge of the blower assembly by removing the nuts, washers and screws.
- b. Remove the cover from the blower assembly by removing the nuts, washers and screws.
- c. Remove the blower fan from the motor shaft by removing the set screw.
- d. For removal of the motor, proceed as follows:
 1. Separate the plate from the motor cover by carefully drilling out the connecting rivets.
 2. Cut the motor wires at the edge of the receptacle and plug and remove the wire ends from the blocks.
 3. Remove the motor from the mounting plate by removing the nuts, washers and bolts.

14-135. REASSEMBLY OF BLOWER ASSEMBLY.

- a. Mount the motor on the plate and secure it with the bolts, washers and nuts. Be sure that the motor nuts are snug and the shaft spins freely.
- b. Position the cover over the motor plate with the motor wires protruding through the cover grommet.
- c. With the holes in the cover matching the holes in the motor plate, secure the two parts together with rivets.
- d. Apply PRC-5000 sealant to fill any opening left after the wires are brought through the grommet.
- e. Install the wires in the plug and receptacle according to Table XIV-XII.
- f. Position the blower fan on the motor shaft and secure with set screw.
- g. Secure the cover to the blower assembly with screws, washers and nuts.
- h. Position the hose duct on the blower assembly and secure it with screws, washers and nuts. The screws must be installed with their heads inside the duct.
- i. After cleaning the surfaces of all old sealant, use white rubber caulk PRC-5000 sealant to seal where the duct attaches to the blower assembly.

14-136. INSTALLATION OF BLOWER ASSEMBLY.

- a. Position the blower assembly in the hangers and retainer and install the washers and screws.
- b. Install the nuts, washers, and screws securing the blower assembly to the hanger braces.
- c. Seal all hose joints with Arno No. C-520 gray tape; then install the inlet and outlet hoses securing them with the clamps.
- d. With the master switch off, connect the plug and receptacles at the blower.
- e. Check the blower for the proper operation.
- f. Install the access door to the aft wall of the baggage area and secure with the attaching hardware.

PIPER SENECA II SERVICE MANUAL

TABLE XIV-XII. BLOWER SYSTEM WIRE COLOR CODES

	MOTOR WIRES			AIRCRAFT WIRES		
		Pin Nos.	YY1S062 ESB - Universal Elect. Company	Aircraft Harness	Pin Nos.	
Ground	Plug	2	Brown	AC26A	2	Receptacle
Low Speed		1	Yellow	Black	1	
High Speed	Receptacle	1	Orange	Red	1	Plug

NOTE

Pin number 1 is at the pointed side of the plug and receptacle.

14-137. SHOULDER HARNESS INERTIA REEL ADJUSTMENT.

- a. Allow the harness to wind up on the reel as much as possible.
- b. On the end of the reel, pry off the plastic cap over the spring, making sure the spring does not come out of the plastic cap and set cap aside.
- c. Unwind the harness completely, then measure and mark the harness 24 inches from the reel center.
- d. Wind the harness onto the reel until the 24 inch mark is reached, then hold reel and place cap with spring over the reel shaft end.
- e. Aligning slot in shaft with spring tang, wind spring 6 turns \pm 1/2 turn and snap the plastic cover into holes in reel end shaft.
- f. Release harness and allowing it to wind up, extend the harness a few times to check reel for smooth operation.
- g. With reel fully wound, hold with inertia mechanism end and pry off plastic cap over mechanism and set reel aside.
- h. Install nut in plastic cap so that stud in cap is flush with nut surface, then reposition cap over reel end and orientating properly, snap in place. Extend harness a few times to make sure action is correct.

PIPER SENECA II SERVICE MANUAL

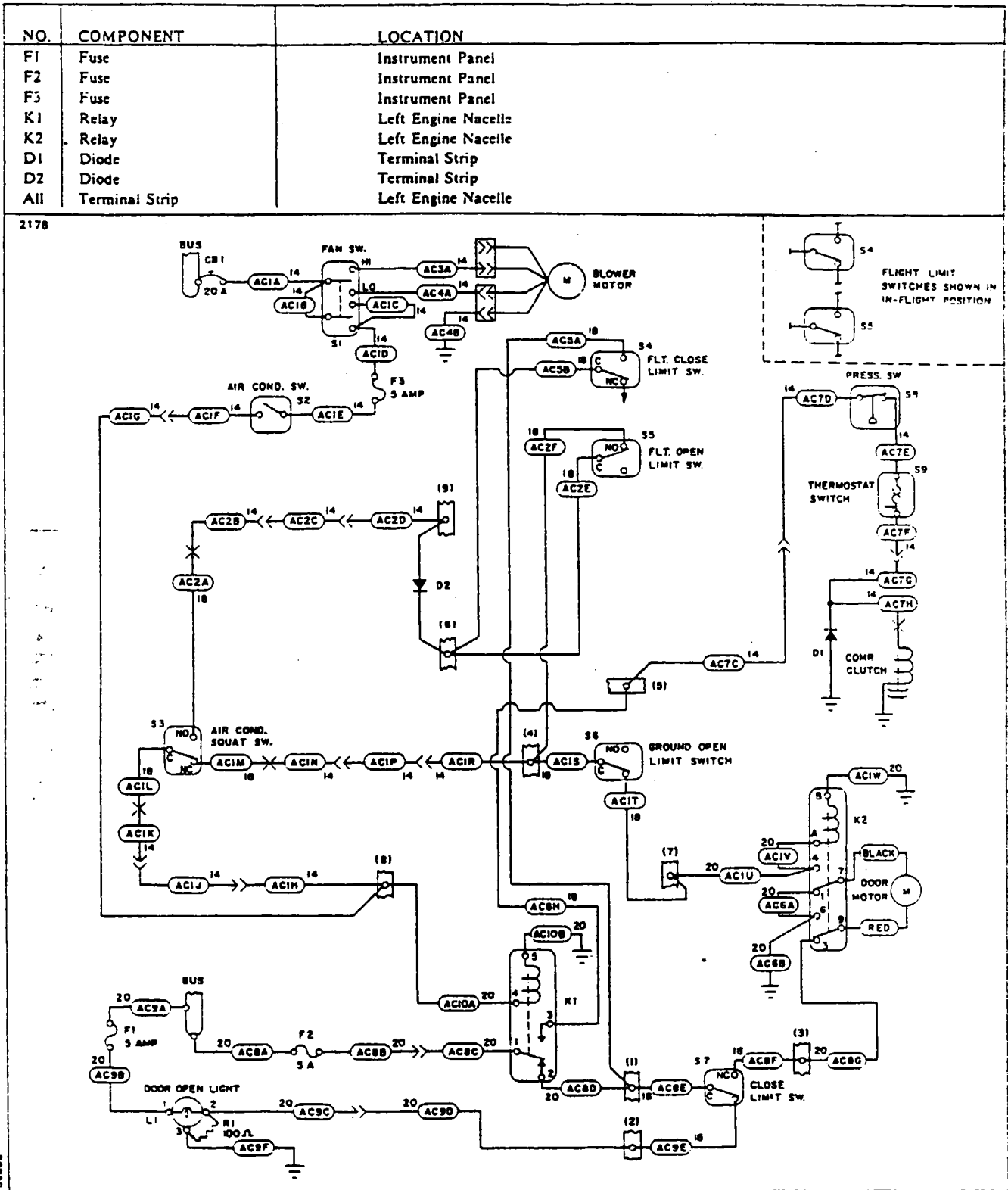

Figure 14-36. Air Conditioning Wiring Schematic (Early Models)

Reissued: 10/11/79

3E1

ACCESSORIES AND UTILITIES

PIPER SENECA II SERVICE MANUAL

TABLE XIV-XIII. TROUBLESHOOTING CHART (AIR CONDITIONER)

Gauge Indication	Probable Causes	Remedy
<p>High discharge pressure.</p>	<p>Overcharge of refrigerant.</p> <p>Air in system.</p> <p>Overheated condenser due to blocking air passage.</p> <p>Flooded evaporator indicated by heavy frosting on suction line and compressor suction service valve.</p> <p>Restriction in liquid line from condenser.</p>	<p>Purge excess refrigerant.</p> <p>Check for leaks. Bleed charge from system. Evacuate and recharge system</p> <p>Clean bugs and dirt from condenser fins. Straighten fins if bent.</p> <p>Check that capillary bulb is securely clamped to suction line. If capillary bulb OK replace expansion valve.</p> <p>Check for kinked hoses and stopped up filter.</p>
<p>Low discharge pressure.</p>	<p>Undercharge of refrigerant. Sight glass shows bubbles or foam.</p> <p>Damaged compressor valves or dirt under valves.</p> <p>Damaged compressor. Worn or broken piston or piston rings.</p>	<p>Add refrigerant until bubbles disappear. Check system leaks</p> <p>Replace compressor.</p> <p>Replace compressor</p>

TABLE XIV-XIII. TROUBLESHOOTING CHART (AIR CONDITIONER) (cont.)

Gauge Indication	Probable Causes	Remedy
<p>Low suction pressure. (Accompanied by icing evaporator.)</p>	<p>Low air supply through evaporator.</p> <p>Very dirty evaporator fins and coils.</p>	<p>Repair blower or blower motor. Clean stoppage in air ducts.</p> <p>Clean and flush with water.</p>
<p>Low suction pressure. (Evaporator not cold enough) suction gauge may read a vacuum indicating evaporator lacks refrigerant.</p>	<p>Undercharge of refrigerant. Moisture freezing in expansion valve. Valve will show frost. Expansion valve inlet screen clogged. Inoperative expansion valve. Valve stuck closed or capillary bulb has lost its charge.</p> <p>Restriction anywhere in liquid line. Restriction will show frost.</p>	<p>Add refrigerant. Install new dryer. Evacuate and recharge</p> <p>Remove screen. Clean with solvent and replace. Warm capillary by holding in hand. If suction pressure does not change, replace expansion valve.</p> <p>Locate restriction and repair.</p>
<p>High suction pressure.</p>	<p>Capillary bulb clamp loose on suction line. Suction line shows frost.</p> <p>Expansion valve not closing. Evaporator flooded. Suction line frosted to compressor.</p>	<p>Clean contact surfaces of suction line and cap bulb. Tighten clamp.</p> <p>Replace expansion valve.</p>

PIPER SENECA II SERVICE MANUAL

TABLE XIV-XIII. TROUBLESHOOTING CHART (AIR CONDITIONER) (cont.)

Gauge Indication	Probable Causes	Remedy
High suction pressure. (cont.)	Compressor drive belt slipping. Magnetic clutch slipping. Leaking or broken compressor valves.	Adjust belt tension. Check electrical circuit for correct voltage to clutch coil. Clean clutch surfaces of oil. Replace compressor.
Trouble	Cause	Remedy
Door will not close when air conditioner switch is in OFF position.	Faulty relay "K-2."	Replace relay.
System produces no cooling.	<u>Electrical.</u> Blown fuse in control head. Open circuit breaker. Broken or disconnected electrical wire. Broken or disconnected ground wire. Clutch coil burned out or disconnected.	Replace fuse. Reset circuit breaker. Check all terminals for loose connections; check wiring for hidden breaks. Check ground wire to see if loose, broken, or disconnected. Check current flow to clutch, replace if inoperative.

TABLE XIV-XIII. TROUBLESHOOTING CHART (AIR CONDITIONER) (cont.)

Trouble	Cause	Remedy
<p>System produces no cooling. (cont.)</p>	<p><u>Electrical.</u> (cont.)</p> <p>Thermostat sensing element defective.</p> <p>Blower motor disconnected or burned out.</p> <p><u>Mechanical</u></p> <p>Loose or broken drive belt.</p> <p>Compressor partially or completely frozen.</p> <p>Expansion valve stuck in open position.</p> <p>Refrigeration</p> <p>Broken refrigerant line.</p> <p>Leak in system.</p>	<p>Check thermostat and cabin comfort control panel.</p> <p>Check current flow to blower motor. Repair or replace if inoperative.</p> <p>Replace drive belts and/or tighten to specifications</p> <p>Remove compressor for service or replacement,</p> <p>Replace expansion valve.</p> <p>Examine all lines for evidence of breakage by external stress or rubbing wear.</p> <p>Evacuate system, apply static charge, leak test system, and repair leak as necessary.</p>

PIPER SENECA II SERVICE MANUAL

TABLE XIV-XIII. TROUBLESHOOTING CHART (AIR CONDITIONER) (cont.)

Trouble	Cause	Remedy
<p>System produces no cooling. (cont.)</p>	<p>Compressor shaft seal leaking.</p> <p>Clogged screen or screens in receiver dehydrator or expansion valve; plugged hose or coil.</p>	<p>Replace compressor.</p> <p>Repair as necessary.</p>
<p>System will not produce sufficient cooling.</p>	<p><u>Electrical</u></p> <p>Blower motor sluggish in operation.</p> <p><u>Mechanical</u></p> <p>Compressor clutch slipping.</p> <p>Obstructed blower passage.</p> <p>Insufficient air circulation over condenser coils; fins clogged with dirt or bugs.</p> <p>Evaporator filter clogged.</p> <p><u>Refrigeration</u></p> <p>Insufficient refrigerant in system.</p>	<p>Remove blower motor for service or replacement.</p> <p>Remove clutch assembly for service or replacement.</p> <p>Examine entire passage for obstruction. Correct as necessary.</p> <p>Clean condenser coils.</p> <p>Clean with cleaning solvent to remove cigarette tars.</p> <p>Recharge system until bubbles disappear in receiver dehydrator and gauge readings stabilize to specifications.</p>

TABLE XIV-XIII. TROUBLESHOOTING CHART (AIR CONDITIONER) (cont.)

Trouble	Cause	Remedy
<p>Excessively noisy system. (cont.)</p>	<p><u>Electrical</u></p> <p>Compressor noisy.</p> <p>Compressor oil level low.</p> <p><u>Refrigeration</u></p> <p>Excessive charge in system.</p> <p>Low charge in system.</p> <p>Excessive moisture in system.</p>	<p>Check mountings and repair; remove compressor for service or replacement.</p> <p>Fill with correct amount of specified oil.</p> <p>Discharge excess freon until high pressure gauge drops within specifications.</p> <p>Check system for leaks; charge system.</p> <p>Replace dehydrator; purge, evacuate, and charge system.</p>

PIPER SENECA II SERVICE MANUAL

TABLE XIV-XIII. TROUBLESHOOTING CHART (AIR CONDITIONER) (cont.)

Trouble	Cause	Remedy
<p>System will not produce sufficient cooling. (cont.)</p>	<p><u>Mechanical</u></p> <p>Clogged screen in expansion valve.</p> <p>Expansion valve thermal bulb has lost charge.</p> <p>Clogged screen in receiver dehydrator.</p> <p>Excessive moisture in system.</p> <p>Air in system.</p>	<p>Purge system and replace expansion valve.</p> <p>Purge system; replace expansion valve.</p> <p>Purge system; replace receiver dehydrator.</p> <p>Purge system; replace receiver dehydrator.</p> <p>Purge, evacuate and charge system (Replace receiver dehydrator.)</p>
<p>Excessively noisy system.</p>	<p><u>Electrical</u></p> <p>Defective winding or improper connection in compressor clutch coil.</p> <p><u>Mechanical</u></p> <p>Loose or excessively worn drive belts.</p> <p>Noisy clutch.</p>	<p>Replace or repair as necessary.</p> <p>Tighten or replace as required</p> <p>Remove clutch for service or replacement as necessary.</p>

14-138. ENGINE SYNCHROPHASER.

14-139. DESCRIPTION OF SYNCHROPHASER SYSTEMS. Two types of synchrophasing systems are being used in the Seneca II, one utilizing an "AUTO SYNCH/MANUAL" (ASM) control, the other an "OFF/PHASE ADJUSTMENT" (OPA) control. The functional equipment is the same for both systems, and consists of right and left pulse generators, phasing computer, and a 5 amp circuit breaker. Schematic descriptions for the two systems can be found in Figures 14-37 and 14-37a.

The two systems are designed to hold the engines in synch, or phase, after the engines have been manually synchronized to within 30 to 40 RPM. The computer senses the out of synch/phase condition with the switches turned on, and automatically tunes the slave (right) engine with that of the master (left) engine. Should the circuit breaker be pulled, master switch switched off, or an electrical failure occur, the slave engine will return to the controlled (selected) RPM, plus approximately 25 RPM "out of synch" regardless of the position of the control switch. Both systems must be turned off (or in manual) during taxi, takeoff, landing, and single engine operation.

The "Auto Synch/Manual" (ASM) control system operates on a fixed phase angle basis and only controls the synchronization through the particular phase angle of the master engine. This system cannot be adjusted in flight.

With the "Phase Adjustment" (OPA) control system, the phase angle of the propellers can be adjusted by rotating the switch in the "Phase Adjustment" range to obtain the smoothest operation.

14-140. SYSTEM OPERATING PROCEDURE. The selector switch must be in the manual or off position during engine start, warm-up, taxi, and take-off.

NOTE

With full throttle and full RPM the governors should be set within the synchrophasing range; if not consult Section VIII of this Service Manual for high RPM setting adjustment.

Upon reaching cruise configuration the propellers should be synchronized manually to within approximately 30 RPM for the ASM control system, and 40 RPM for the OPA system. For system activation the ASM switch should be moved to the "Auto Sync" position and the OPA rotary switch moved slightly into the "Phase Adjustment" position. The particular system should synchronize the propellers in a few seconds but occasionally may take up to a full minute for the ASM system or 30 seconds for the OPA system.

The ASM control system should synchronize or phase in the engines as previously described; however, if the power settings are changed, or if an RPM differential between the two engines exceeds 50 RPM, the switch should be placed in "Manual" for 30 to 40 seconds and the procedure reinitiated.

The OPA system has the advantage over the ASM system in that the phase angle of the propellers can be adjusted by rotating the switch to obtain the smoothest operation. After any adjustment remember to wait at least 30 seconds. When changing power settings the system should be turned off and the previous procedures reinitiated.

PIPER SENECA II SERVICE MANUAL

14-140a. **INDUCTOR AND KIT INSTALLATIONS.** (Refer to Figures 14-37 and 14-37a.) On early installations which used the "Auto Synchronizer Manual" controlled system, an inductor was not incorporated in the system but was added later to remove radio interference. If the inductor or a newer computer (which has the inductor incorporated) have not been retrofitted, the schematics herein and available kits should be appropriately considered.

14-141. **SYNCHROPHASER SYSTEM CHECK AND ADJUSTMENT.** The following wiring harness checks require the use of Hartzell Test Set B-4467.

- a. Power light operating—indicates power supply to the system computer is of the proper polarity.
- b. Right or Left engine lights operating—indicates pulse generator for applicable engine is operating properly and correctly wired.
- c. AUTO SYNC or MANUAL light operating—aircraft system AUTO SYNC/MANUAL switch is wired correctly.
- d. Coil light operating—governor solenoid coil is wired correctly.
- e. Coil light not operating—open circuit, or wire on Pin Number 8 is grounded.
- f. Coil short light operating—short circuit in governor solenoid coil or a short between coil leads.

14-142. **GROUND CHECKS.**

- a. Disconnect the synchrophaser computer from the wiring harness.
- b. Connect Hartzell Test Set B-4467 to wiring harness at point where computer was disconnected.
- c. Turn battery master switch ON and place synchrophaser mode switch in AUTO SYNC position. Test set power light and coil light should be lighted.

NOTE

Other lights on the test set may be lighted, but should be ignored with this exception: if coil short light is lighted, place aircraft master switch in off position and replace governor solenoid coil.

d. If either the right or left engine lights are lighted, attempt to extinguish the light by rotating appropriate propeller in direction of normal rotation. If lights are not lighted, attempt to light by rotating propeller.

e. Place synchrophaser mode switch in the manual position. The test set manual light should light and the phase light should extinguish. Placing mode switch in AUTO SYNC position should cause the reverse to occur.

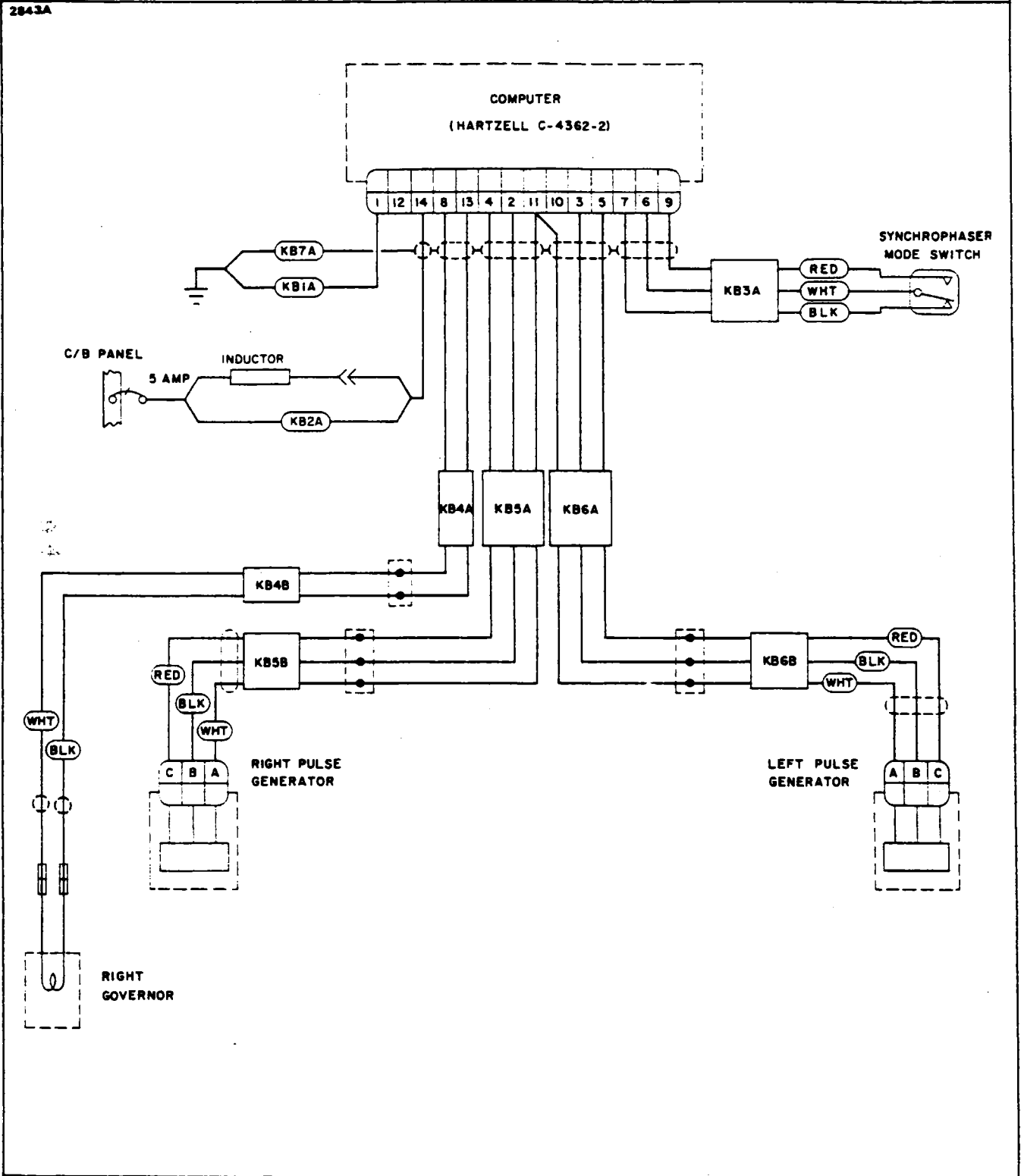

Figure 14-37. Synchronphaser Wiring Schematic — Auto Synch/Manual Switch

Revised: 8/10/80

3E11

ACCESSORIES AND UTILITIES

PIPER SENECA II SERVICE MANUAL

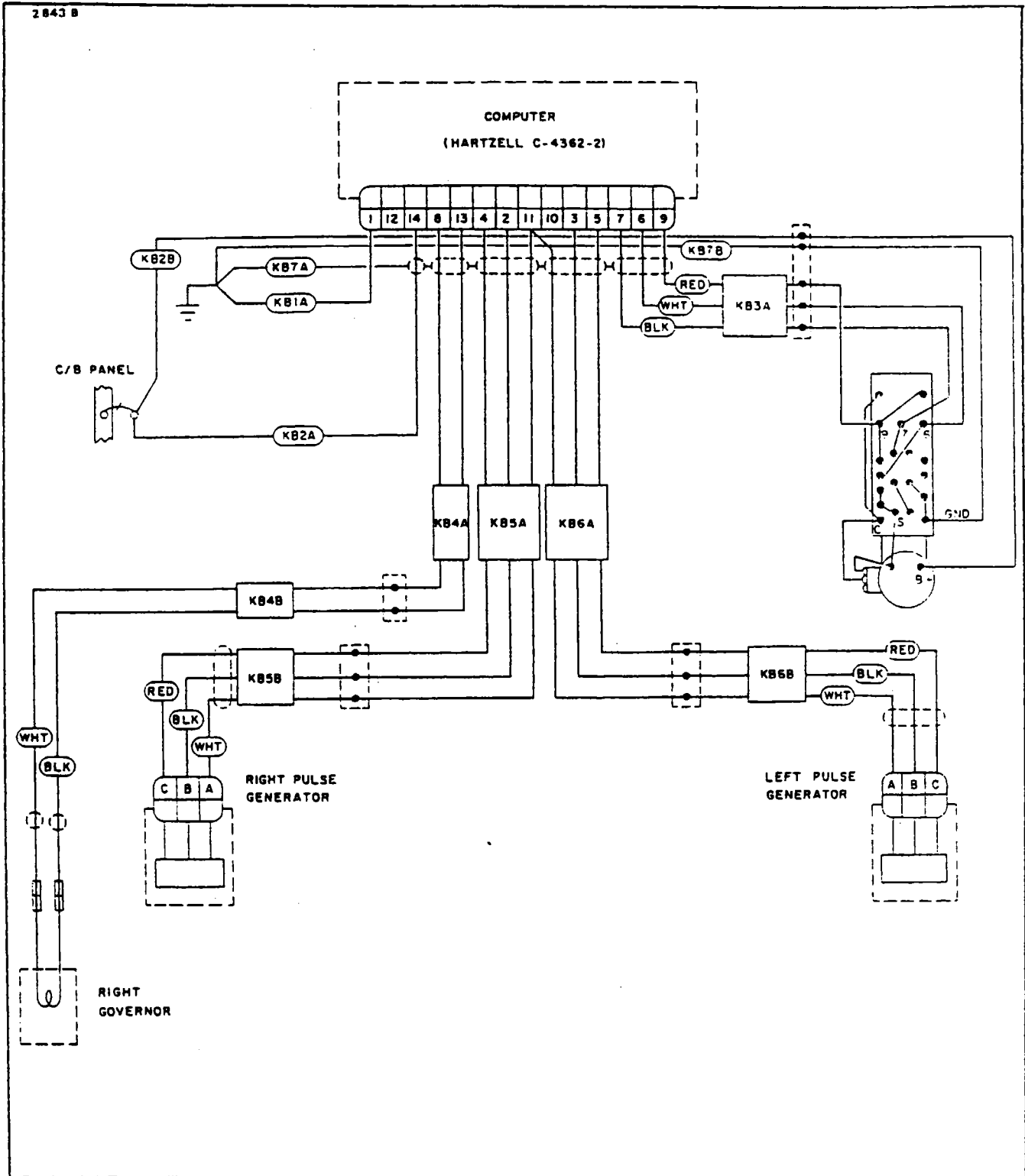

Figure 14-37a. Synchrophaser Wiring Schematic — Phase Adjustment Switch

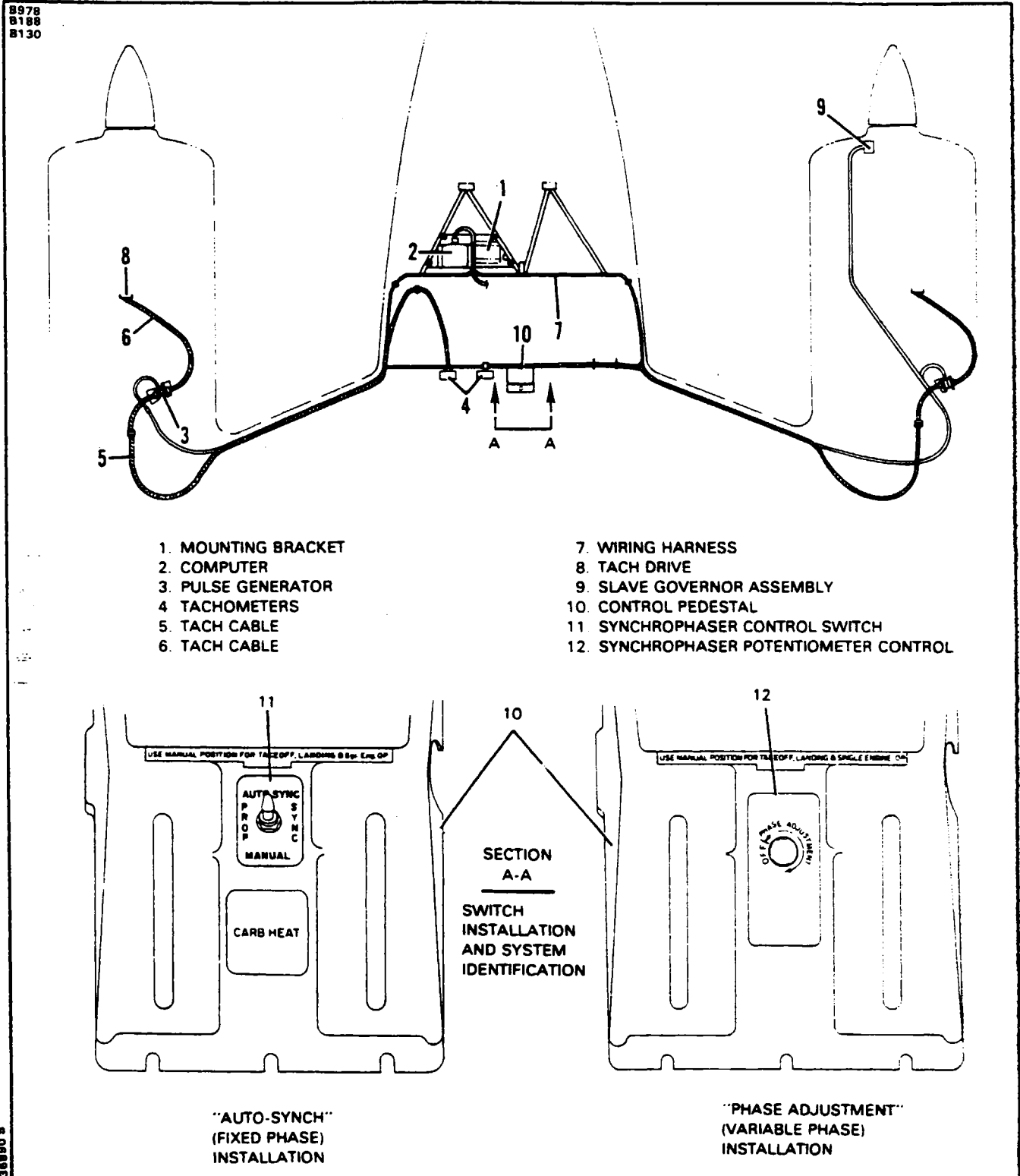

Figure 14-38. Engine Synchrophaser Installation

Revised: 8/10/80

3E13

ACCESSORIES AND UTILITIES

NOTE

Failure of test lights to operate may indicate a defective wiring harness. Should the wiring harness prove to be good, but the engine lights or coil light fail to function properly, replace the applicable pulse generator or governor.

- f. Disconnect the test set from the aircraft and reconnect the computer.

14-143. FLIGHT CHECK.

- a. At cruise altitude, set the engine controls at 75 percent power.
- b. Beat synchronize the propellers.
- c. With the propeller control, increase or decrease right engine speed approximately 50 revolutions per minute (RPM).
- d. Place the synchrophaser mode switch in the AUTO SYNC position. The propellers will synchronize automatically if the system is operating properly. If synchronization is not attained return mode switch to MANUAL for 30 to 45 seconds. Resynchronize the engines manually to within 25 to 30 RPM of each other. Return the mode switch to the AUTO SYNC position. If synchronization is again not attained, repeat 14-143 above, then repeat flight check.

NOTE

Place synchrophaser mode switch in manual position for all take-off, landing and engine-out operations.

14-144. REMOVAL OF COMPUTER ASSEMBLY.

The computer assembly is located in the nose section of the aircraft at station 49.50. It is mounted on the de-ice mounting bracket which is in turn attached to the nose gear mount lower tubes.

- a. Remove baggage compartment trim panels to gain access to the computer.
- b. Disconnect the electrical plug from the computer assembly.
- c. Remove the four (4) screws and washers securing the computer assembly to the mounting bracket.
- d. Remove the computer assembly from the airplane.

14-145. INSTALLATION OF COMPUTER ASSEMBLY.

- a. Position the computer assembly on the mounting bracket and secure with screws and washers previously removed.
- b. Reconnect electrical plug to computer assembly.
- c. Install baggage compartment trim panels previously removed.

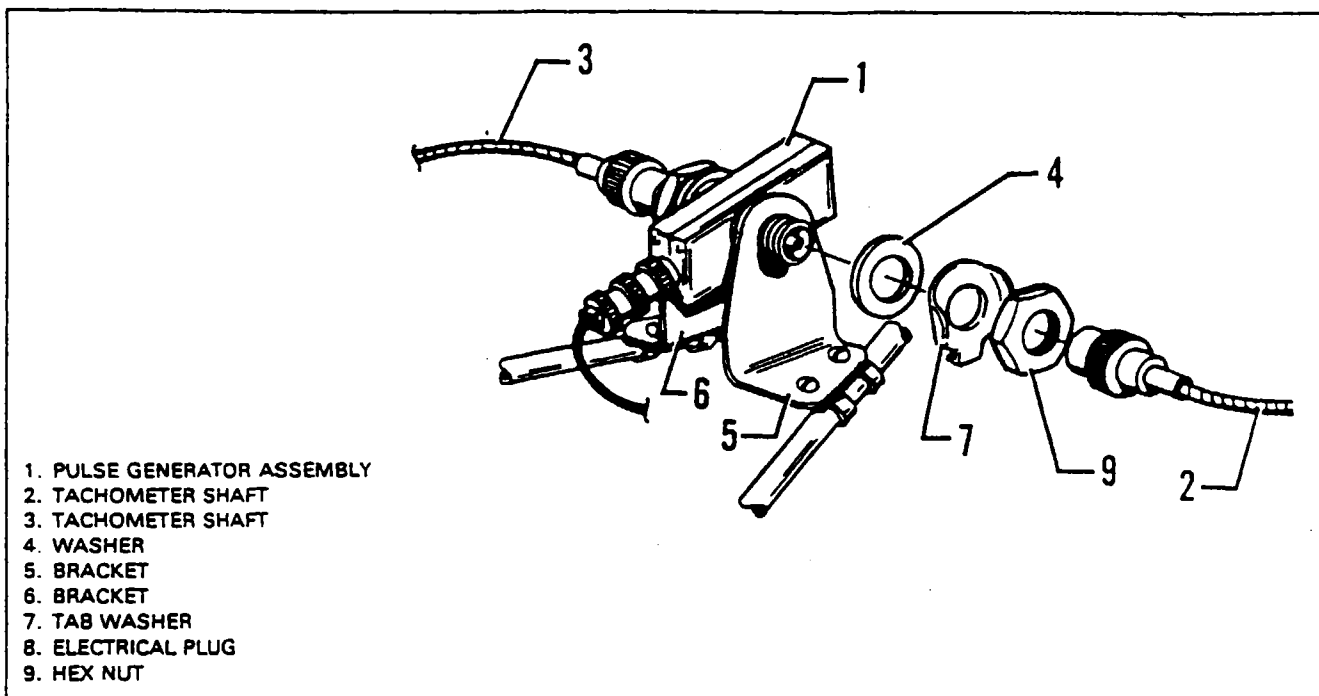

Figure 14-39. Pulse Generator Installation

14-146. REMOVAL OF PULSE GENERATOR (Figure 14-39.)

There is a pulse generator on each engine. They are mounted on the engine mount tubes at the top of the engine.

- a. Remove the engine cowling right access panel.
- b. Remove the electrical plug (8) from the pulse generator (1).
- c. Loosen the knurled nuts securing the tachometer shafts to the pulse generator and remove the shafts from the pulse generator assembly.
- d. Remove the two hex nuts (9), tab washers (7) and washers (4).
- e. Loosen the screws and nuts securing the mounting brackets (5 & 6) to the engine mount tubes.
- f. Spread the brackets sufficiently to allow the pulse generator to be removed.

14-147. INSTALLATION OF PULSE GENERATOR (Figure 14-39.)

- a. Place the pulse generator in position between the mounting brackets (5 & 6).
- b. Press brackets together and install washer (4), a new tab washer (7) and the hex nut (9).
- c. Tighten the nuts and screws securing the brackets to the engine mount tubes.
- d. Attach tachometer shafts (2 & 3) to pulse generator.
- e. Attach the electrical plug to the pulse generator.

3E16 THRU 3L24
INTENTIONALLY LEFT BLANK